

## 一. 社会調査の結果



## 1. 日本での社会調査の結果





【Q6】現在の安全衛生法が1972年に成立してから、日本の労働災害は大きく減少しました。その理由として考えられる同法の長所をすべてお答えください。(お答えはいくつでも)(N=1000)

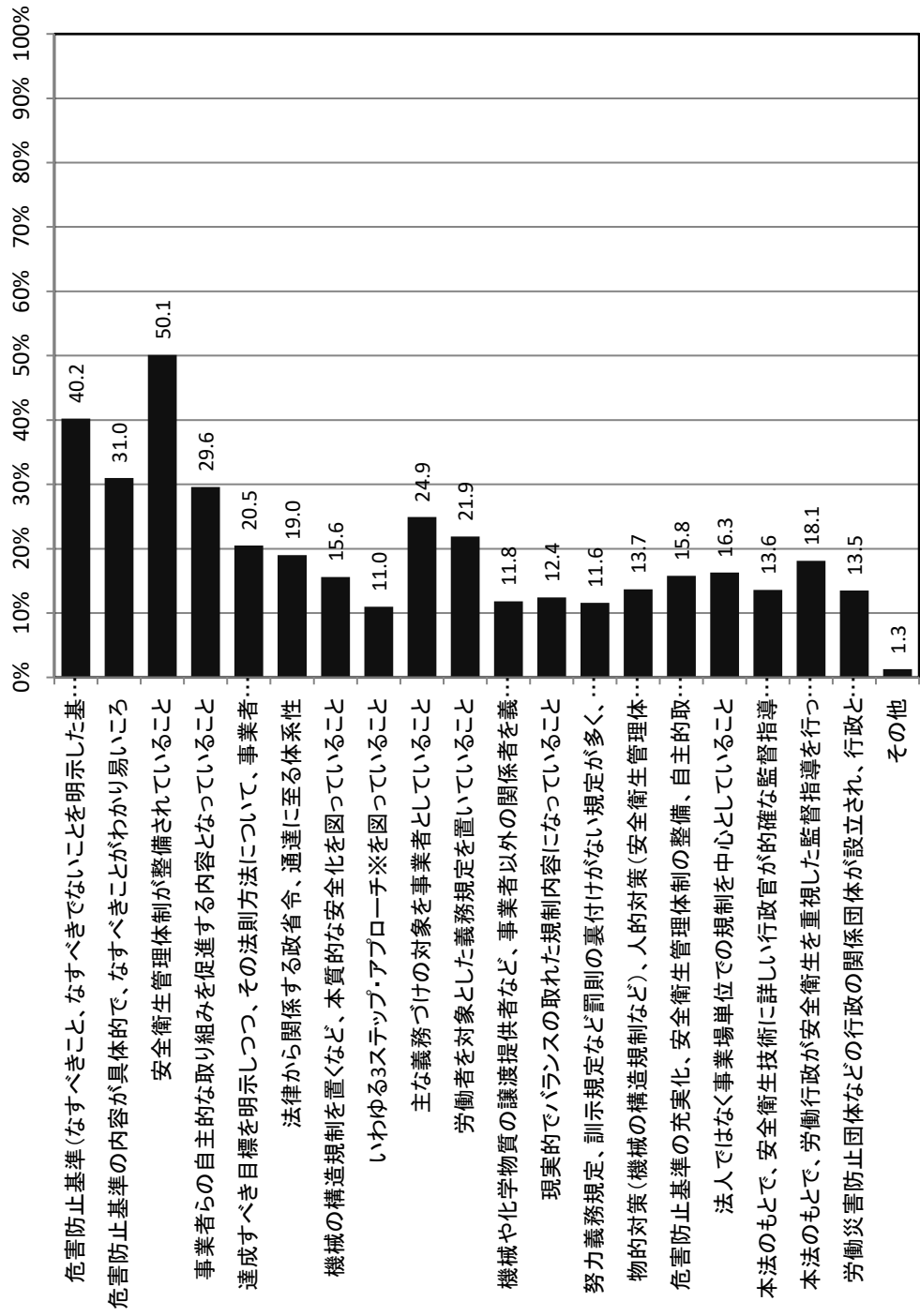

【Q7】現在の安全衛生法について、専門家が本格的に検討すべきと思われる課題を、次の中から3つお答えください。(お答えは3つ)  
(N=1000)

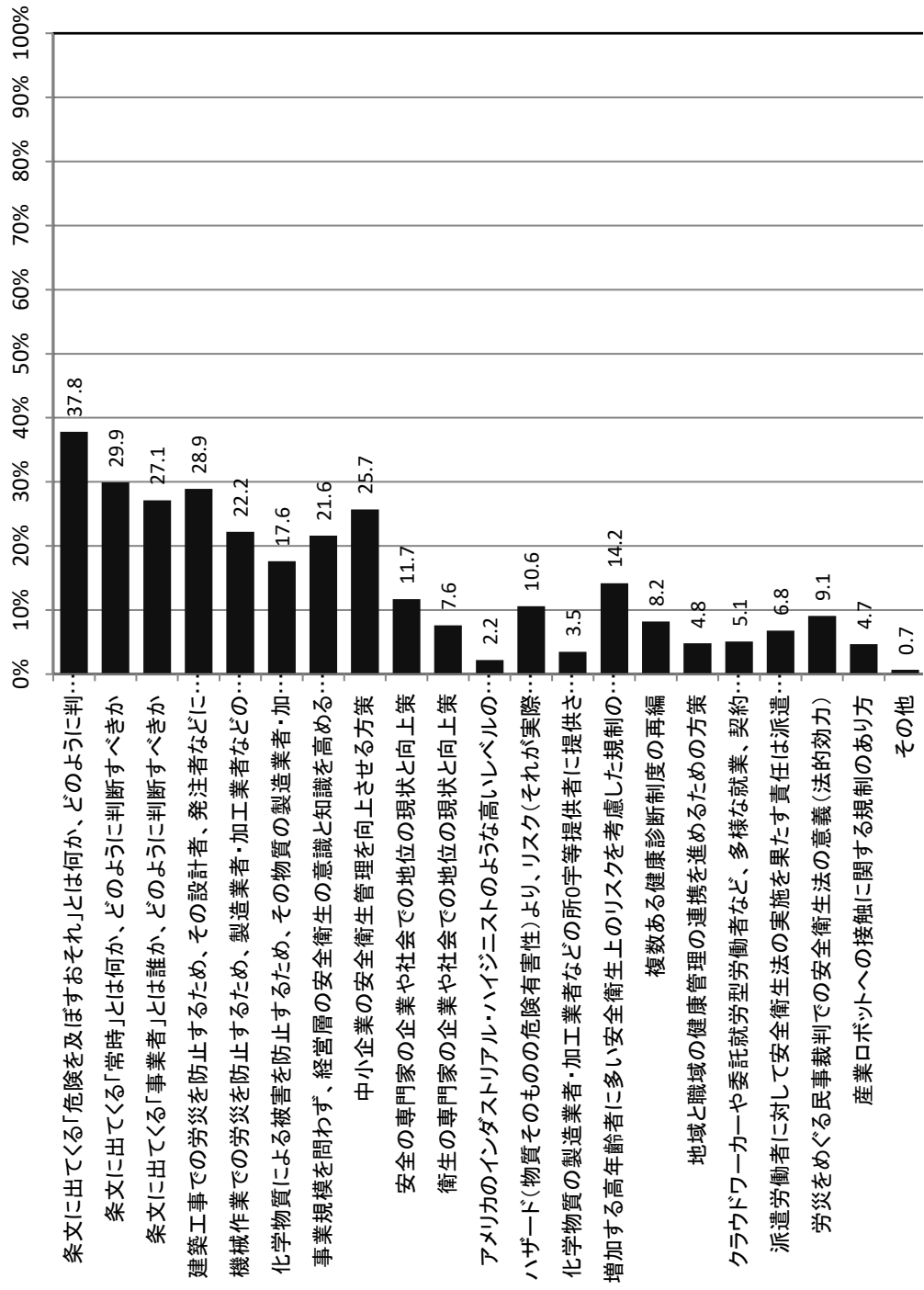

[GRAPH014]

【Q8】 経営上、安全衛生を重視していますか。(お答えは1つ)  
(N=260)

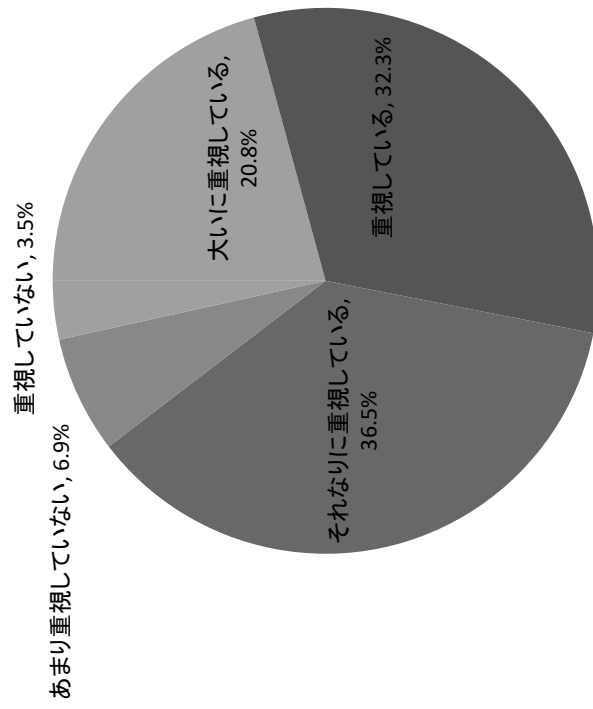

[GRAPH015]

【Q9】前問で、「大いに重視している、重視している」とお答えになった方にお伺いします。その理由としてあてはまるものを3つまでお答えください。(お答えは3つまで)  
(N=138)

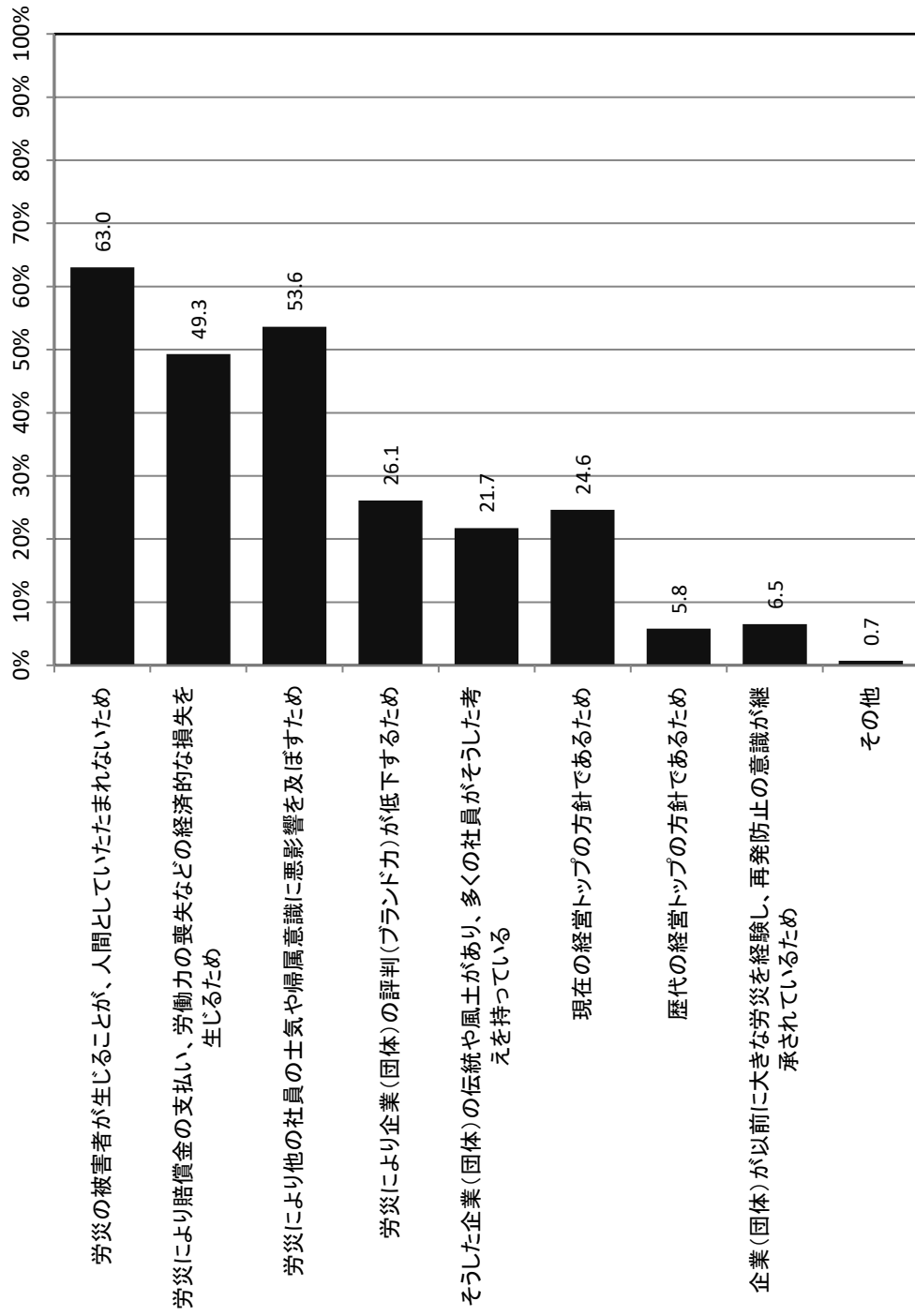

[GRAPH016]

【Q10】 経営上、安全衛生について「大いに重視している、重視している」しており、所属先の従業員数が500人以上の方にお伺いいたします。具体的にどのような施策を講じていますか。あてはまるものを3つまでお答えください。(お答えは3つまで)  
(N=13)

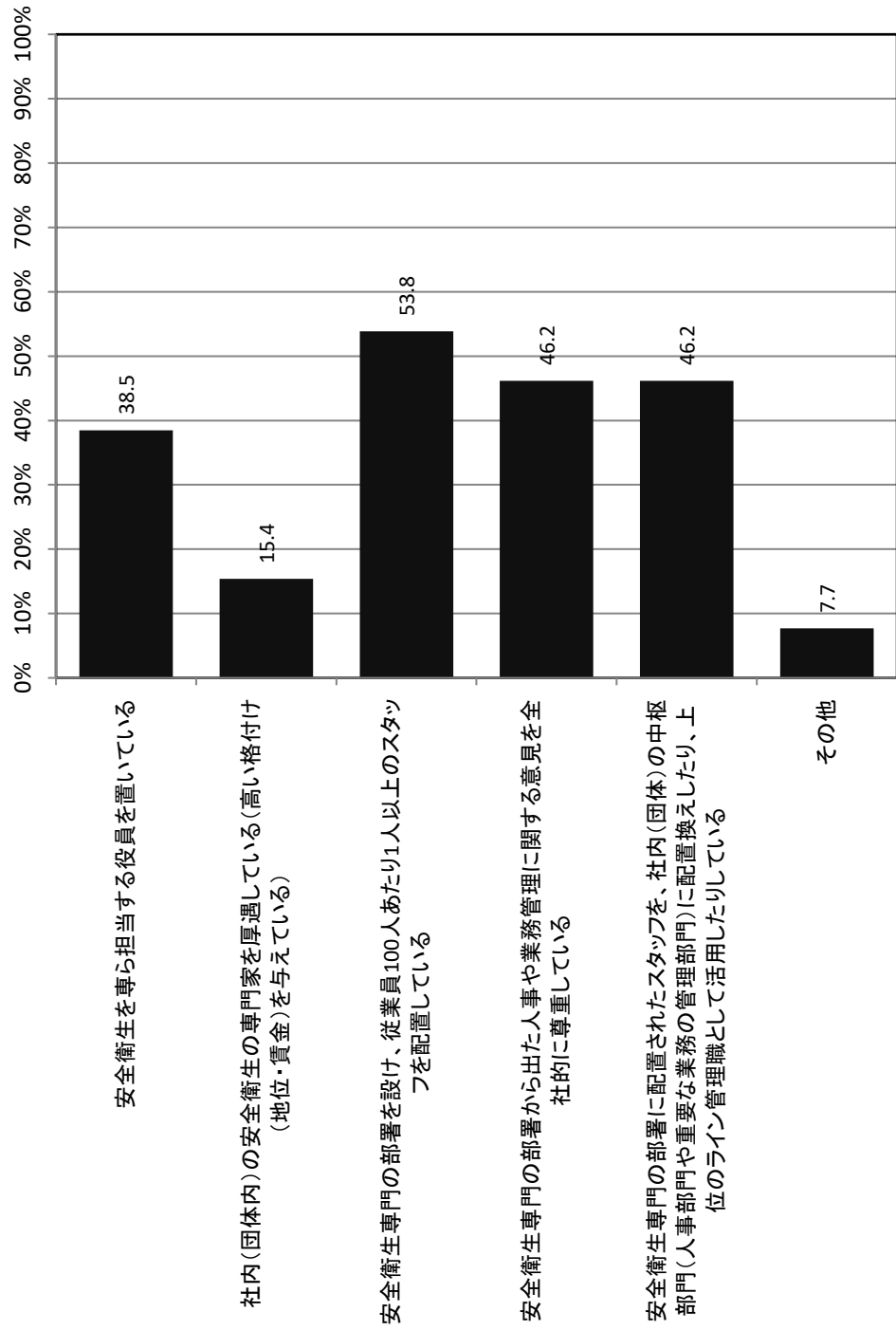

[GRAPH017]

【Q11】 経営上、安全衛生について「大いに重視している、重視している」しており、所属先の従業員数が100人未満の方にお伺いいたします。具体的にどのような施策を講じていますか。あてはまるものを3つまでお答えください。(お答えは3つまで)  
(N=104)

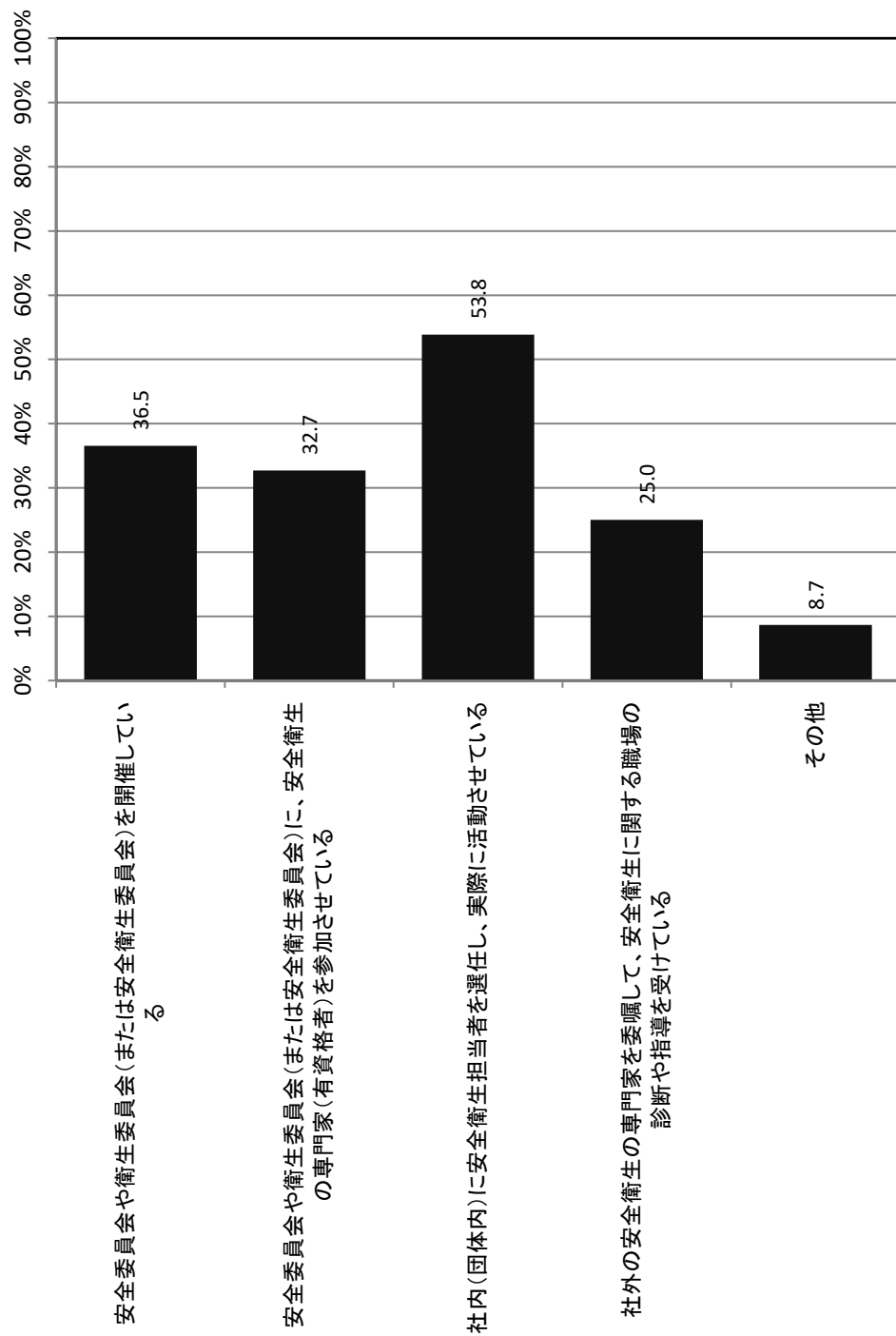

[GRAPH018]

【Q12】経営上、安全衛生について「あまり重視していない、重視していない」しており、所属先の従業員数が100人以上の方にお伺いいたします。その理由を3つまでお答えください。（お答えは3つまで）  
(N=27)

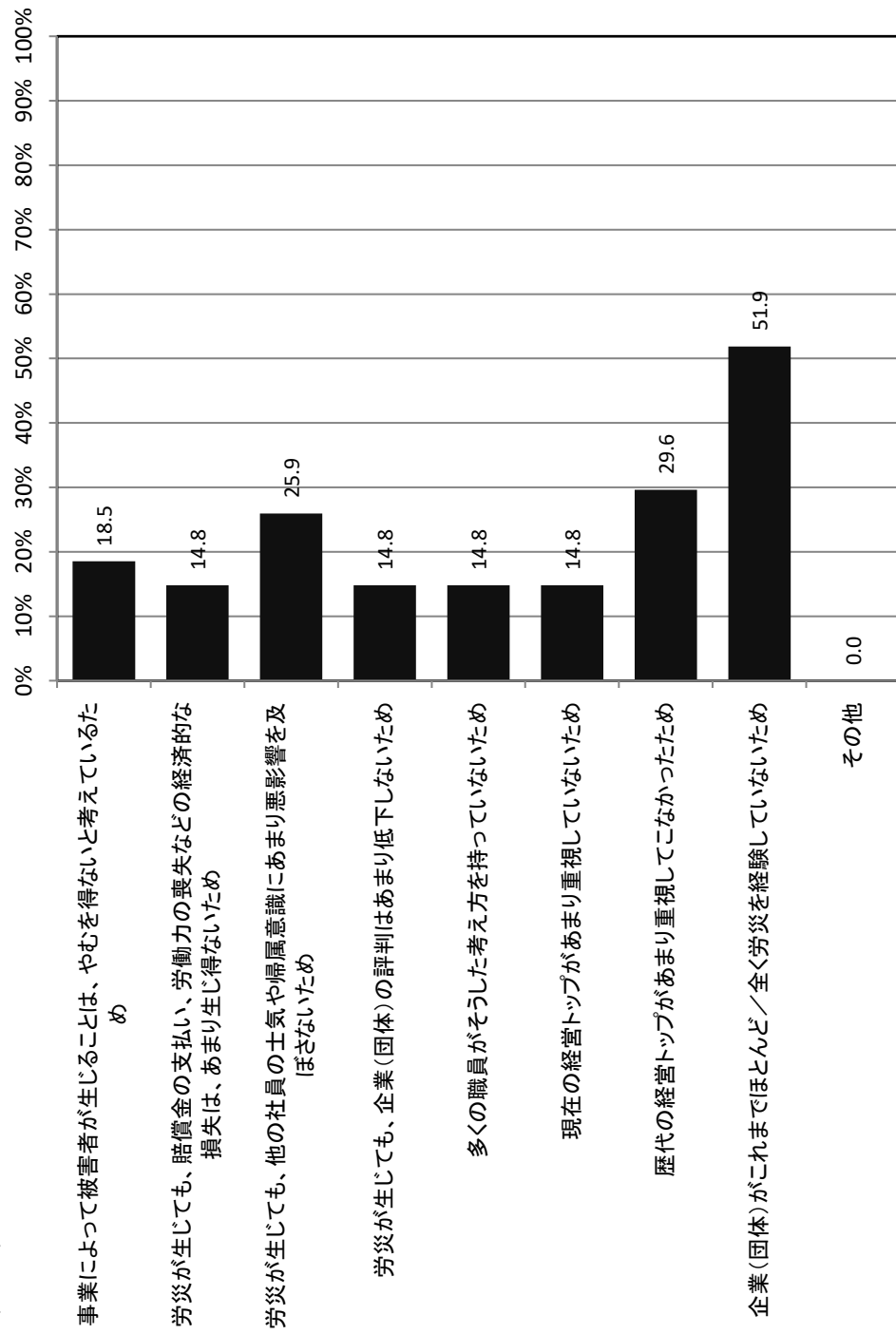





## 2. UK での社会調査の結果



# Survey on occupational safety and health law policy

## Number of questions

18 questions in total

## Implementing entity

Research Project supported by 2019-2021 grants-in-aid for scientific research from Japan's Ministry of Health, Labor, and Welfare (National Institute of Occupational Safety and Health project)

## Purpose

Policy recommendations to Japan's Ministry of Health, Labor and Welfare

## Target

Persons in charge of HRM, safety and health personnel, managers, directors, officers, and other persons related to safety and health in companies and other organizations

## Cross search

Q4 – Q9

Q5 – Q9

Q6 – Q9

Q7 – Q9

## 1. Questions about the attributes of respondents

Q1

Please answer your gender. (One answer)

- 1 male
- 2 women

## Q2

Please tell us your age. (One answer)

- 1 20s
- 2 30s
- 3 40s
- 4 50s
- 5 60s and over

## Q3

Please tell us the country you work in. (One answer)

- 1 England
- 2 Wales
- 3 Scotland
- 4 Northern Ireland

## Q4

Please answer your occupation. (One answer)

- 1 Managers, executives and senior officials
- 2 Professional occupations
- 3 Associate professional and technical occupations
- 4 Administrative and secretarial occupations
- 5 Skilled trades occupations
- 6 Caring, leisure and other service occupations

- 7 Sales and customer service occupations
- 8 Process, plant and machine operatives
- 9 Elementary occupations
- 10 Others

## Q5

Please tell us about your position within the company (organization) you operate or belong to. (Any number of answers)

- 1 Company/Organization Manager
- 2 Executive/Board Member
- 3 Middle Manager (in HRM division)
- 4 Middle Manager (in other than HRM division)
- 5 Professionals (other than safety and health related)
- 6 Professionals (safety and health related)
- 7 Subordinate (in HRM division)
- 8 Subordinate (in other than HRM division)
- 9 Others
- 10 Not applicable - I don't have any management responsibility.

.

## Q6

Please tell us about the type of business of the company (organization) you operate or belong to. (One answer)

\* If there are multiple applicable industries, please answer the one that you are mainly involved in.

- 1 Agriculture
- 2 Forestry
- 3 Fisheries
- 4 Mining
- 5 Construction industry
- 6 Manufacturing industry
- 7 Electricity, gas, heat supply, water supply
- 8 Information and communication industry

- 9 Transportation industry
- 10 Wholesale / Retail
- 11 Finance / Insurance
- 12 Real estate industry
- 13 Restaurant / accommodation business
- 14 Medical and welfare
- 15 Education / learning support
- 16 Service industry (not classified elsewhere)
- 17 National institutions (those not classified elsewhere)
- 18 Local government (not classified elsewhere)
- 19 Others

### Q7

Are you involved in work related to the safety and health of the company (organization) to which you operate or belong? (One answer)

- 1 Directly involved
- 2 Indirectly involved
- 3 Not involved

### Q8

Please tell us about the number of employees of the company (organization) you operate or belong to. (One answer each)

- 0 people
- 1-9 people
- 10-49 people
- 50-99 people
- 100-499 people
- 500-999 people
- Over 1,000 people
- I do not know.

## 2. Main Questions

### Q9

How much, if anything do you know about UK Health and Safety Law (the law, regulations, code of conduct, guidelines, etc.) (one answer)?

- 1 A great deal
- 2 I generally know A fair amount
- 3 Only a little
- 4 Hardly anything
- 5 Nothing at all

### Q10

I would like to ask those who answered "A great deal" or "A fair amount" in the previous question (Q9).

When thinking about health and safety regulation in the UK, which of the following most closely resembles your view?

- 1 Too strict
- 2 Generally appropriate
- 3 Not strict enough
- It varies across different areas

### Q11

I would like to ask those who answered "A great deal" or "A fair amount" in Q9.

Still thinking about health and safety regulation in the UK, which of the following most closely resembles your view?

- 1 Regulation is easy to understand and implement
- 2 There are some aspects that are difficult to understand, but it can be implemented with

guidance

3 It is too complicated to understand and implement

## Q12

Since the current Health and Safety at Work Act (HSWA) was enacted in 1974, the number of fatal-injuries in the UK has decreased by more than 80%. What, if anything, do you see as the main reason(s) for this? Please select all that apply

- 1 Comprehensive hazard prevention standards (i.e. standards that clearly indicate what should be done and what should not be done)
- 2 Implementation of a health and safety management system(e.g. the appointment of a health and safety manager)
- 3 Better cooperation and coordination when multiple employers carry out construction at the same location
- 4 Stronger voluntary efforts of staff and management towards health and safety within the workplace
- 5 Allowing businesses sufficient freedoms to enact their own changes
- 6 Easy to understand the relationship between laws, regulations, code of conduct, and guidance
- 7 So-called three-step approach (First, take essential safety measures, second, take engineering measures for risks that cannot be dealt with by that, and third, take human measures such as education for the remaining risks to prevent industrial accidents) is employed
- 8 Employer liability
- 9 Potential fines for employees who breach regulations
- 10 Measures to prevent occupational accidents (providing safe products, providing information on risks, etc.) are passed throughout the supply chain
- 11 There is an evaluation and registration system for machinery and chemical substances treated in workplace.
- 12 Realistic and well-balanced regulations
- 15 Under this law, HSE (Health and Safety Executive) has implemented appropriate health and safety guidance based on high expertise.
- 16 . Regular inspections and guidance from independent health and safety inspectors
- 17 Under this law, a safety representative has supported the health and safety management of employers.



- 19 . Fines being issued to employers in the past
- 20 Potential fines for senior management if regulations are violated

\* If other items are provided, please answer freely within 60 words.

### Q13

Regarding the current Industrial Safety and Health Law (HSWA), please select three issues that experts should consider from the following. When thinking about potential changes to the current Health and Safety at Work Act, which of the following issues, if any, do you think need greater focus?

- 1 A stronger definition of 'welfare' in the legal context
- 2 What is "so far as is reasonably practicable" in the text and how should it be recognized?  
A stronger definition of 'reasonable practicable' in the legal context
- 3 Legal nature of the Code of Conduct (ACOP)
- 4 A stronger definition of legal obligations imposed on stakeholders (e.g. managers, designers, manufacturers)
- 7 Strong definition of risk for those working in spaces where harmful substances are handled
- 8 Stronger assessment of risks posed to workers dealing with chemical substances
- 9 Stronger management of risks posed to workers dealing with chemical substances (e.g. controlling exposure)
- 10 Measures to raise management awareness of health and safety regardless of business scale
- 12 Current status/ importance placed on safety specialists in companies and society and measures to improve them
- 13 Current status/ importance placed on hygiene specialists in companies and society and measures to improve them
- 14 Should the appointment of an industrial physician be required by law?
- 15 Introduction of mandatory health checks life
- 16 How to control the safety and health risks of older employees
- 17 Measures to promote cooperation between community and occupational health management
- 18 How safety and health laws and regulations should be for new self-employed people such as cloud workers and freelancers

- 19 Stronger definition on health and safety laws for mobile workers
- 20 Greater focus on employee mental health
- 21 Greater importance of Health and Safety Law in civil cases

\* If other items are provided, please answer freely within 60 words.

## Q14

Regarding Q5, I would like to ask only those who answered 1 (Company/Organization Manager) and 2 (Executive/Board Member).

How much importance do you place on health and safety in management?

- 1 Very important
- 2 Moderately important
- 3 Neutral
- 4 Not very important
- 5 Not at all important

## Q15

I would like to ask those who answered 1 or 2 in the previous question (Q14).

You say that health and safety in management is important. Why do you say this? Please select up to 3 reasons.

- 1 I do not want the emotional toll of being responsible for an accidentlarge compensation
- 3 . An accident could negatively affect company morale
- 4 . An accident could negatively affect my company's reputation
- 5 .
- 6 It is the company policy
- 8 The company (organization) has experienced a major industrial accident before
- 9 I could be punished for violating the law.
- 10 An accident could lead to more absenteeism from employees
- 11 Other (Please specify)

\* If other items are provided, please answer freely within 60 words.

## Q16

Of those who answered 1 or 2 in Q14, I would like to ask those who have more than 500 employees.

In your approach to health and safety, which of the following measures, if any, are you currently taking? Please select up to three.

- 1 We have dedicated senior managers in charge of safety and health.
- 2 We offer generous remuneration for health and safety specialists
- 3 A department in charge of safety and health has been set up, and one or more staff members are assigned for every 100 employees.
- 4 .We respect the authority of the health and safety specialists within the business
- 5 The staff assigned to the department in charge of safety and health is reassigned to a central department (personnel department or business management department) of the company (organization) or appointed as an officer.

\* If other items are provided, please answer freely within 30 words.

## Q17

Of those who answered 1 or 2 in Q14, I would like to ask those who have less than 100 employees.

In your approach to health and safety, which of the following measures, if any, are you currently taking? Please select up to three

- 1 We have a health and safety committee
- 2 An independent health and safety expert is invited to participate in the health and safety committee.
- 3 A health and safety assistant has been appointed within the company
- 4 We have commissioned an external health and safety consultant to conduct a workplace assessment and issue guidance

\* If other items are provided, please answer freely within 30 words.

## Q18

I would like to ask those who answered 4 or 5 in Q14.

You say that health and safety in management is not important. Why do you say this? Please select up to 3 reasons.

- 1 We believe accidents are inevitable in the workplace and cannot be prevented
- 2 . In the event of an accident, it is unlikely we will required to pay compensation
- 3 . In the event of an accident, it is unlikely to negatively affect staff morale
- 4 . In the event of an accident, our reputation will not suffer
- 5 Staff do not place importance on health and safety
- 6 Because the current top management does not place much importance to it.
- 7 Because previous top management did not place much importance to it.8 Because the company (organization) has hardly / never experienced an accident.
- 9 Even if it is punished by law, it will not be a big disadvantage.

\* If other items are provided, please answer freely within 60 words.

**Kindai University - Health & Safety**

Fieldwork Dates: 9th - 18th December 2020

**Conducted by YouGov  
On behalf of Kindai University Osaka**

© YouGov plc 2021

**Kindai University Osaka**  
**Health & Safety survey**

Fieldwork Dates: 9th - 18th December 2020



	Total	Gender		Age					Nation				Managers, executives and senior officials
		Male	Female	20s	30s	40s	50s	60s and over	England	Wales	Scotland	Northern Ireland	
<b>Q1. Please answer your gender</b>													
Base	1005	620	385	35	177	239	335	219	855	35	97	18	571
Male	100%	-	-	46%	47%	54%	69%	74%	61%	60%	67%	56%	65%
Female	38%	100%	-	54%	53%	46%	31%	26%	39%	40%	33%	44%	35%
<b>Q2. Age</b>													
Base	1005	620	385	35	177	239	335	219	855	35	97	18	571
20s	3%	3%	5%	100%	-	-	-	-	3%	-	6%	11%	3%
30s	18%	13%	24%	-	100%	-	-	-	17%	34%	18%	17%	16%
40s	24%	21%	28%	-	-	100%	-	-	24%	20%	23%	28%	24%
50s	33%	37%	27%	-	-	-	100%	-	34%	26%	30%	33%	37%
60s and over	22%	26%	15%	-	-	-	-	100%	22%	20%	24%	11%	19%
<b>Q3. Nation</b>													
Base	1005	620	385	35	177	239	335	219	855	35	97	18	571
England	85%	85%	86%	77%	82%	86%	87%	85%	100%	-	-	-	86%
Wales	3%	3%	4%	-	7%	3%	3%	3%	-	100%	-	-	3%
Scotland	10%	10%	8%	17%	10%	9%	9%	11%	-	-	100%	-	9%
Northern Ireland	2%	2%	2%	6%	2%	2%	2%	1%	-	-	-	100%	2%
<b>Q4. Please answer your occupation.</b>													
Base	1005	620	385	35	177	239	335	219	855	35	97	18	571
Managers, executives and senior officials	57%	60%	52%	49%	53%	58%	63%	50%	57%	54%	53%	56%	100%
Professional occupations	20%	19%	22%	20%	22%	24%	21%	20%	23%	25%	21%	11%	-
Associate professional and technical occupations	6%	6%	5%	6%	6%	2%	6%	8%	6%	3%	6%	11%	-
Administrative and secretarial occupations	3%	1%	6%	3%	5%	3%	2%	3%	3%	3%	1%	6%	-
Skilled trades occupations	3%	5%	1%	3%	2%	3%	4%	5%	4%	-	-	6%	-
Caring, leisure and other service occupations	3%	1%	5%	9%	4%	3%	2%	2%	2%	3%	4%	6%	-
Sales and customer service occupations	2%	2%	2%	9%	2%	2%	1%	4%	2%	-	2%	6%	-
Process, plant and machine operatives	0%	0%	-	-	1%	-	1%	-	0%	-	-	-	-
Elementary occupations	0%	0%	-	-	-	-	0%	1%	0%	3%	1%	-	-
Other	5%	5%	6%	3%	6%	5%	6%	5%	11%	8%	8%	-	-
Not Applicable - I don't work	0%	-	0%	-	-	-	0%	-	0%	-	-	-	-
<b>Q5. Please tell us about your position within the company you operate or belong to.</b>													
Base	1005	620	385	35	177	239	335	219	855	35	97	18	571
Company/Organization Manager	25%	24%	27%	9%	17%	27%	29%	26%	26%	11%	24%	17%	27%
Executive/Board Member	17%	22%	10%	6%	8%	17%	19%	26%	18%	6%	14%	11%	26%
Middle Manager (in HRM division)	6%	5%	8%	9%	12%	5%	6%	4%	6%	9%	5%	28%	7%
Middle Manager (in other than HRM division)	27%	24%	32%	60%	38%	29%	26%	14%	26%	37%	33%	11%	31%
Professionals (other than safety and health related)	11%	11%	11%	14%	14%	11%	8%	13%	11%	17%	12%	17%	4%
Professionals (safety and health related)	4%	5%	2%	3%	4%	2%	4%	4%	4%	3%	2%	6%	2%
Subordinate (in HRM division)	0%	-	1%	-	-	0%	0%	-	0%	3%	-	-	0%
Subordinate (in other than HRM division)	1%	1%	1%	-	1%	-	1%	0%	-	2%	-	-	0%
Others	6%	6%	6%	-	5%	6%	5%	9%	6%	11%	5%	6%	2%
Not applicable - I don't have any management responsibility.	3%	3%	3%	-	2%	3%	2%	5%	3%	3%	2%	6%	0%
<b>Q6. Please tell us about the type of business of the company you operate or belong to. If there are multiple applicable industries, please answer the one that you are mainly involved in.</b>													
Base	1005	620	385	35	177	239	335	219	855	35	97	18	571
Agriculture	1%	1%	1%	-	-	0%	1%	2%	1%	-	1%	-	0%
Forestry	0%	0%	-	-	1%	-	0%	-	0%	3%	-	-	-
Fisheries	0%	0%	-	-	-	-	0%	-	-	-	1%	-	-
Mining	0%	0%	-	-	-	-	0%	-	0%	-	-	-	-
Construction industry	6%	6%	5%	3%	7%	5%	5%	6%	5%	3%	11%	-	4%
Manufacturing industry	10%	13%	6%	6%	10%	9%	12%	11%	10%	14%	6%	17%	14%
Electricity, gas, heat supply, water supply	1%	2%	-	-	-	1%	1%	2%	2%	-	-	-	1%
Information and communication industry	6%	8%	4%	6%	5%	6%	5%	8%	6%	6%	7%	11%	6%
Transportation industry	3%	3%	2%	-	-	3%	5%	2%	3%	-	1%	6%	3%
Wholesale / Retail	6%	7%	5%	9%	10%	5%	6%	5%	6%	-	6%	17%	7%
Finance / Insurance	3%	3%	3%	3%	5%	3%	4%	1%	3%	3%	4%	6%	3%
Real estate industry	4%	5%	3%	6%	3%	5%	4%	5%	4%	-	7%	-	5%
Restaurant / accommodation business	4%	3%	6%	23%	6%	4%	2%	2%	4%	3%	4%	6%	4%
Medical and welfare	7%	5%	10%	6%	11%	6%	7%	7%	7%	11%	9%	6%	6%
Education / learning support	14%	11%	20%	17%	20%	13%	11%	15%	11%	7%	7%	11%	13%
Service industry (not classified elsewhere)	7%	7%	8%	7%	3%	7%	10%	6%	7%	9%	6%	7%	9%
National institutions (those not classified elsewhere)	2%	2%	2%	3%	3%	2%	2%	0%	2%	2%	2%	-	2%
Local government (not classified elsewhere)	4%	4%	3%	3%	3%	2%	5%	3%	4%	3%	3%	-	4%
Others	21%	19%	24%	14%	18%	22%	18%	27%	20%	29%	22%	17%	19%
<b>Q7. Are you involved in work related to the health and of the company to which you operate or belong to?</b>													
Base	1005	620	385	35	177	239	335	219	855	35	97	18	571
Directly involved	51%	51%	50%	46%	51%	49%	54%	48%	52%	57%	38%	50%	54%
Indirectly involved	36%	37%	32%	34%	36%	41%	34%	31%	35%	29%	44%	33%	26%
Not involved	14%	12%	17%	20%	13%	10%	12%	21%	13%	14%	18%	17%	11%
<b>Q8. Please tell us about the number of employees of the company you operate or belong to.</b>													
Base	1005	620	385	35	177	239	335	219	855	35	97	18	571
0 people	-	-	-	-	-	-	-	-	-	-	-	-	-
1-9 people	29%	30%	28%	17%	16%	23%	30%	48%	30%	14%	30%	17%	21%
10-49 people	11%	9%	13%	9%	14%	11%	10%	7%	11%	17%	9%	11%	12%
50-99 people	10%	9%	12%	14%	13%	10%	9%	10%	10%	9%	10%	17%	11%
100-499 people	19%	20%	18%	20%	18%	24%	19%	15%	19%	17%	19%	22%	23%
500-999 people	6%	6%	7%	14%	6%	7%	5%	7%	6%	9%	7%	6%	7%
Over 1,000 people	25%	26%	22%	26%	33%	25%	27%	14%	24%	40%	25%	28%	26%
Don't know	-	-	-	-	-	-	-	-	-	-	-	-	-
<b>Q9. How much, if anything do you know about UK Health and Safety Law (the law, regulations, code of conduct, guidelines, etc.)?</b>													
Base	1005	620	385	35	177	239	335	219	855	35	97	18	571
A great deal	14%	17%	9%	9%	12%	13%	18%	12%	14%	17%	13%	17%	17%
A fair amount	47%	49%	44%	49%	42%	46%	48%	50%	48%	40%	41%	44%	50%
Only a little	30%	26%	36%	29%	33%	33%	27%	28%	29%	34%	28%	28%	26%
Hardly anything	8%	7%	9%	9%	11%	7%	7%	7%	7%	11%	9%	11%	6%
Nothing at all	2%	1%	3%	6%	2%	1%	1%	3%	2%	3%	2%	-	1%
<b>Q10. When thinking about health and safety regulation in the UK, which of the following most closely resembles your view?</b>													
Base	610	409	201	20	96	139	220	135	526	20	53	11	380
Too strict	11%	11%	10%	20%	9%	6%	13%	13%	11%	10%	9%	9%	13%
Generally appropriate	79%	78%	79%	75%	82%	80%	80%	72%	78%	80%	85%	73%	78%
Not strict enough	5%	4%	6%	5%	4%	7%	2%	7%	5%	-	6%	9%	4%
It varies across different areas	6%	6%	4%	-	4%	7%	4%	8%	6%	10%	-	9%	5%
<b>Q11. Still thinking about health and safety regulation in the UK, which of the following most closely resembles your view?</b>													
Base	610	409	201	20	96	139	220	135	526	20	53	11	380
Regulation is easy to understand and implement	23%	23%	23%	15%	27%	27%	20%	20%	22%	40%	19%	27%	23%
There are some aspects that are difficult to understand, but it can be implemented with guidance	72%	71%	74%	85%	71%	68%	72%	76%	72%	55%	75%	73%	71%
It is too complicated to understand and implement	5%	6%	3%	-	2%	4%	8%	4%	5%	5%	6%	-	6%
<b>Q12. Since the current Health and Safety at Work Act (HSWA) was enacted in 1974, the number of fatal-injuries in the UK has decreased by more than 80%. What, if anything, do you see as the main reason(s) for this? Please select all that apply</b>													
Base	1005	620	385	35	177	239	335	219	855	35	97	18	571
Comprehensive hazard prevention standards (i.e. standards that clearly indicate what should be done and what should not be done)	48%	48%	49%	37%	45%	49%	48%	54%	49%	40%	46%	44%	51%
Implementation of a health and safety management system (e.g. the appointment of a health and safety manager)	51%	51%	50%	43%	45%	50%	55%	52%	51%	49%	46%	61%	53%
Better cooperation and coordination when multiple employers carry out construction at the same location	20%	22%	16%	20%	19%	17%	18%	27%	19%	20%	23%	33%	18%
Stronger voluntary efforts of staff and management towards health and safety within the workplace	31%	33%	26%	31%	22%	28%	32%	38%	31%	20%	30%	22%	32%
Allowing businesses sufficient freedoms to enact their own changes	10%	11%	6%	11%	8%	8%	8%	14%	10%	9%	9%	11%	10%
Easy to understand the relationship between laws, regulations, code of conduct, and guidance	17%	17%	18%	23%	17%	15%	16%	20%	17%	23%	13%	28%	18%

**Kindai University Osaka**  
**Health & Safety survey**

Fieldwork Dates: 9th - 18th December 2020



	Total	Gender		Age					Nation				Managers, executives and senior officials	
		Male	Female	20s	30s	40s	50s	60s and over	England	Wales	Scotland	Northern Ireland		
So-called three-step approach (First, take essential safety measures, second, take engineering measures for risks that cannot be dealt with by that, and third, take human measures such as education for the remaining risks to prevent industrial accidents) is employed	30%	32%	25%	26%	29%	30%	30%	30%	29%	34%	32%	22%	31%	
Employer liability	54%	55%	53%	51%	51%	54%	56%	54%	54%	46%	61%	61%	54%	
Potential fines for employees who breach regulations	32%	33%	30%	37%	29%	34%	30%	32%	32%	34%	26%	28%	32%	
Measures to prevent occupational accidents (providing safe products, providing information on risks, etc.) are passed throughout the supply chain	52%	49%	56%	49%	47%	51%	53%	55%	52%	51%	46%	44%	53%	
There is an evaluation and registration system for machinery and chemical substances treated in workplace	26%	28%	23%	31%	23%	24%	25%	33%	27%	26%	24%	22%	27%	
Realistic and well-balanced regulations	28%	31%	24%	34%	24%	28%	29%	29%	28%	26%	28%	28%	28%	
Under this law, the HSE (Health and Safety Executive) has implemented appropriate health and safety guidance based on high expertise	43%	44%	43%	40%	46%	43%	41%	46%	45%	51%	31%	28%	43%	
Regular inspections and guidance from independent health and safety inspectors	37%	34%	41%	49%	40%	35%	33%	38%	36%	37%	34%	56%	36%	
Under this law, a safety representative has supported the health and safety management of employers	23%	23%	23%	14%	18%	26%	25%	23%	23%	17%	20%	50%	25%	
Fines being issued to employers in the past	29%	30%	27%	29%	32%	28%	31%	25%	29%	29%	26%	22%	28%	
Potential fines for senior management if regulations are violated	38%	40%	35%	34%	31%	37%	42%	39%	38%	31%	38%	39%	38%	
Other	4%	5%	2%	-	3%	2%	4%	5%	4%	3%	5%	-	3%	
Don't know	8%	8%	7%	9%	8%	10%	6%	8%	8%	9%	6%	-	6%	
<b>Q13. When thinking about potential changes to the current Health and Safety at Work Act, which of the following issues, if any, do you think need greater focus?</b>	<b>Base</b>	1005	620	385	35	177	239	335	219	855	35	97	18	571
A stronger definition of 'welfare' in the legal context		23%	25%	19%	23%	19%	24%	25%	21%	21%	20%	35%	28%	21%
A stronger definition of 'reasonable practicable' in the legal context		27%	27%	28%	20%	23%	24%	28%	32%	27%	26%	30%	33%	28%
Legal nature of the Code of Conduct (ACOP)		11%	12%	9%	-	10%	10%	11%	15%	11%	14%	11%	22%	11%
A stronger definition of legal obligations imposed on stakeholders (e.g. managers, designers, manufacturers)		23%	27%	17%	11%	15%	20%	28%	26%	23%	14%	28%	22%	25%
Stronger definition of risk for those working in spaces where harmful substances are handled		14%	15%	12%	9%	7%	10%	15%	22%	13%	17%	16%	11%	13%
Stronger assessment of risks posed to workers dealing with chemical substances		19%	20%	19%	20%	15%	17%	21%	23%	19%	26%	16%	33%	18%
Stronger management of risks posed to workers dealing with chemical substances (e.g. controlling exposure)		19%	20%	17%	14%	14%	21%	18%	23%	19%	29%	13%	33%	17%
Measures to raise management awareness of health and safety regardless of business scale		28%	29%	27%	17%	19%	27%	32%	33%	28%	34%	28%	39%	32%
Current status/ importance placed on safety specialists in companies and society and measures to improve them		11%	11%	10%	11%	9%	8%	13%	11%	10%	14%	13%	17%	11%
Current status/ importance placed on hygiene specialists in companies and society and measures to improve them		9%	9%	8%	3%	11%	6%	10%	8%	9%	14%	6%	6%	7%
The appointment of an industrial physician be required by law		5%	5%	5%	3%	6%	6%	5%	5%	-	2%	-	6%	5%
Introduction of mandatory health checks		17%	16%	17%	23%	12%	15%	18%	19%	17%	11%	14%	28%	14%
How to control the safety and health risks of older employees		17%	16%	18%	17%	14%	14%	19%	20%	16%	29%	20%	11%	16%
Measures to promote cooperation between community and occupational health management		11%	12%	10%	9%	10%	10%	11%	14%	11%	11%	18%	6%	10%
How safety and health laws and regulations should be for self-employed people such as cloud workers and freelancers		24%	24%	24%	20%	22%	22%	25%	27%	24%	31%	22%	17%	23%
Stronger definition on health and safety laws for mobile workers		21%	22%	19%	9%	16%	21%	21%	26%	20%	29%	20%	28%	21%
Greater focus on employee mental health		40%	38%	42%	51%	37%	41%	41%	36%	40%	34%	41%	44%	39%
Greater importance of Health and Safety Law in civil cases		12%	12%	12%	9%	8%	11%	13%	15%	11%	12%	15%	33%	11%
Other		4%	5%	2%	-	2%	3%	4%	6%	4%	6%	5%	-	3%
Don't know		21%	21%	20%	14%	23%	25%	18%	20%	22%	14%	13%	11%	19%
<b>Q14. How much importance do you place on health and safety in management?</b>	<b>Base</b>	424	281	143	5	44	104	159	112	376	6	37	5	304
Very important		67%	66%	71%	40%	43%	61%	77%	71%	68%	83%	65%	40%	70%
Moderately important		25%	25%	24%	60%	48%	29%	16%	21%	24%	17%	24%	60%	22%
Neutral		6%	6%	5%	-	5%	10%	4%	5%	6%	-	8%	-	5%
Not very important		1%	2%	-	-	-	1%	2%	2%	2%	-	-	-	2%
Not at all important		1%	1%	-	-	5%	-	1%	-	1%	-	3%	-	1%
<b>Q15. You say that health and safety in management is important. Why do you say this? Please select up to three reasons.</b>	<b>Base</b>	390	254	136	5	40	93	148	104	346	6	33	5	280
I do not want the emotional toll of being responsible for an accident		52%	48%	57%	40%	50%	56%	53%	47%	53%	17%	52%	20%	51%
An accident could lead to paying a large compensation		24%	23%	26%	40%	40%	20%	24%	21%	25%	33%	12%	40%	26%
An accident could negatively affect company morale		36%	36%	36%	40%	28%	34%	36%	40%	35%	67%	36%	80%	39%
An accident could negatively affect my company's reputation		47%	47%	49%	40%	40%	51%	51%	42%	47%	50%	52%	80%	49%
It is the company policy		27%	30%	21%	40%	30%	20%	23%	36%	27%	33%	24%	40%	28%
The company has experienced a major industrial accident before		3%	3%	3%	-	10%	2%	2%	3%	17%	3%	3%	-	4%
I could be punished for violating the law		27%	28%	27%	60%	35%	29%	26%	24%	27%	33%	36%	20%	26%
An accident could lead to more absenteeism from employees		17%	18%	17%	20%	23%	20%	18%	13%	18%	-	15%	20%	18%
Other		14%	15%	13%	20%	3%	14%	14%	19%	14%	-	21%	-	14%
<b>Q16. In your approach to health and safety, which of the following measures, if any, are you currently taking? Please select up to three.</b>	<b>Base</b>	127	92	35	1	11	34	54	27	111	2	13	1	111
We have dedicated senior managers in charge of health and safety		67%	68%	63%	100%	64%	59%	69%	74%	66%	100%	69%	100%	69%
We offer generous remuneration for health and safety specialists		13%	10%	20%	100%	27%	15%	7%	11%	11%	-	31%	-	13%
A department in charge of safety and health has been set up, and one or more staff members are assigned for every 100 employees		22%	22%	23%	-	36%	32%	19%	11%	21%	50%	23%	100%	22%
We respect the authority of the health and safety specialists within the business		66%	65%	69%	-	64%	62%	65%	78%	68%	50%	54%	100%	68%
The staff assigned to the department in charge of safety and health is reassigned to a central department (personnel department or business management department) of the company or appointed as an officer		33%	32%	37%	-	36%	32%	33%	33%	33%	50%	31%	-	33%
Other		5%	7%	-	-	-	3%	6%	7%	5%	-	8%	-	5%
None of these		5%	4%	6%	-	9%	9%	-	7%	5%	-	8%	-	4%
<b>Q17. In your approach to health and safety, which of the following measures, if any, are you currently taking? Please select up to three.</b>	<b>Base</b>	263	162	101	4	29	59	94	77	235	4	20	4	169
We have a health and safety committee		16%	17%	16%	-	10%	15%	23%	12%	16%	25%	15%	50%	20%
An independent health and safety expert is invited to participate in the health and safety committee.		11%	12%	9%	-	10%	10%	16%	6%	12%	-	5%	-	14%
A health and safety assistant has been appointed within the company		28%	25%	32%	75%	31%	29%	30%	21%	27%	50%	35%	25%	33%
We have commissioned an external health and safety consultant to conduct a workplace assessment and issue guidance		22%	25%	17%	50%	14%	20%	30%	16%	22%	-	15%	100%	28%
Other		10%	12%	7%	-	3%	8%	10%	16%	10%	-	15%	-	7%
None of these		37%	34%	42%	-	41%	41%	31%	42%	37%	25%	40%	-	28%
<b>Q18. You say that health and safety in management is not important. Why do you say this? Please select up to 3 reasons.</b>	<b>Base</b>	10	10	-	-	2	1	5	2	9	-	1	-	8
We believe accidents are inevitable in the workplace and cannot be prevented		30%	30%	-	-	50%	-	40%	-	22%	-	100%	-	25%
In the event of an accident, it is unlikely we will be required to pay compensation		30%	30%	-	-	50%	-	20%	50%	33%	-	-	-	25%
In the event of an accident, it is unlikely to negatively affect staff morale		10%	10%	-	-	-	-	20%	-	11%	-	-	-	13%
In the event of an accident, our reputation will not suffer		20%	20%	-	-	-	-	40%	-	22%	-	-	-	25%
Staff do not place importance on health and safety		-	-	-	-	-	-	-	-	-	-	-	-	-
Because the current top management does not place much importance to it		-	-	-	-	-	-	-	-	-	-	-	-	-
Because previous top management did not place much importance to it		-	-	-	-	-	-	-	-	-	-	-	-	-
Because the company has hardly / never experienced an accident		40%	40%	-	-	-	100%	60%	-	44%	-	-	-	50%
Even if it is punished by law, it will not be a big disadvantage		20%	20%	-	-	-	-	40%	-	22%	-	-	-	25%
Other		20%	20%	-	-	-	-	20%	50%	22%	-	-	-	25%

Cell Contents (Column Percentages)

**Kindai University Osaka**  
**Health & Safety survey**

Fieldwork Dates: 9th - 18th December 2020



	Total	Occupation										Company/Orga nization Manager	Executive/Boar d Member	Middle Manager (in HRM division)	
		Professional occupations	Associate professional and technical occupations	Administrative and secretarial occupations	Skilled trades occupations	Caring, leisure and other service occupations	Sales and customer service occupations	Process, plant and machine operatives	Elementary occupations	Other					
<b>Q1. Please answer your gender</b>															
Base	1005	202	56	30	34	27	24	3	3	54	250	174	65		
Male	62%	59%	63%	20%	88%	33%	63%	100%	100%	54%	59%	77%	51%		
Female	38%	41%	38%	80%	12%	67%	38%	-	-	46%	41%	23%	49%		
<b>Q2. Age</b>															
Base	1005	202	56	30	34	27	24	3	3	54	250	174	65		
20s	3%	3%	4%	3%	3%	11%	13%	-	-	2%	1%	1%	5%		
30s	18%	19%	18%	30%	9%	26%	17%	33%	-	19%	12%	8%	32%		
40s	24%	28%	19%	23%	24%	26%	17%	-	-	22%	26%	23%	20%		
50s	33%	26%	38%	23%	35%	22%	21%	67%	-	33%	31%	39%	31%		
60s and over	22%	23%	32%	20%	29%	15%	33%	-	-	67%	26%	32%	12%		
<b>Q3. Nation</b>															
Base	1005	202	56	30	34	27	24	3	3	54	250	174	65		
England	85%	83%	84%	90%	97%	78%	88%	100%	33%	78%	88%	90%	80%		
Wales	3%	4%	2%	3%	-	4%	-	-	33%	7%	2%	1%	5%		
Scotland	10%	12%	11%	3%	-	15%	8%	-	33%	15%	9%	8%	8%		
Northern Ireland	2%	1%	4%	3%	3%	4%	4%	-	-	-	1%	1%	8%		
<b>Q4. Please answer your occupation.</b>															
Base	1005	202	56	30	34	27	24	3	3	54	250	174	65		
Managers, executives and senior officials	57%	-	-	-	-	-	-	-	-	-	62%	85%	60%		
Professional occupations	20%	100%	-	-	-	-	-	-	-	-	16%	11%	23%		
Associate professional and technical occupations	6%	-	100%	-	-	-	-	-	-	-	6%	2%	6%		
Administrative and secretarial occupations	3%	-	-	100%	-	-	-	-	-	-	2%	-	5%		
Skilled trades occupations	3%	-	-	-	100%	-	-	-	-	-	5%	-	2%		
Caring, leisure and other service occupations	3%	-	-	-	-	100%	-	-	-	-	2%	1%	-		
Sales and customer service occupations	2%	-	-	-	-	-	100%	-	-	-	2%	-	2%		
Process, plant and machine operatives	0%	-	-	-	-	-	-	100%	-	-	0%	-	-		
Elementary occupations	0%	-	-	-	-	-	-	-	100%	-	-	-	2%		
Other	5%	-	-	-	-	-	-	-	-	100%	-	1%	2%		
Not Applicable - I don't work	0%	-	-	-	-	-	-	-	-	-	-	-	-		
<b>Q5. Please tell us about your position within the company you operate or belong to.</b>															
Base	1005	202	56	30	34	27	24	3	3	54	250	174	65		
Company/Organization Manager	25%	19%	25%	17%	35%	22%	21%	33%	-	22%	100%	-	-		
Executive/Board Member	17%	9%	7%	-	4%	-	-	-	-	4%	100%	-	-		
Middle Manager (in HRM division)	6%	7%	7%	10%	3%	-	4%	-	33%	2%	-	-	100%		
Middle Manager (in other than HRM division)	27%	18%	20%	47%	12%	44%	38%	33%	-	17%	-	-	-		
Professionals (other than safety and health related)	11%	30%	25%	3%	15%	4%	13%	33%	33%	7%	-	-	-		
Professionals (safety and health related)	4%	6%	11%	-	-	-	4%	-	-	4%	-	-	-		
Subordinate (in HRM division)	0%	-	-	3%	-	-	-	-	-	-	-	-	-		
Subordinate (in other than HRM division)	1%	1%	-	3%	4%	-	-	-	-	2%	-	-	-		
Others	6%	3%	5%	17%	21%	19%	13%	-	33%	33%	-	-	-		
Not applicable - I don't have any management responsibility.	3%	5%	-	3%	12%	4%	8%	-	-	9%	-	-	-		
<b>Q6. Please tell us about the type of business of the company you operate or belong to. If there are multiple applicable industries, please answer the one that you are mainly involved in.</b>															
Base	1005	202	56	30	34	27	24	3	3	54	250	174	65		
Agriculture	1%	1%	2%	-	6%	4%	-	-	-	2%	1%	1%	-		
Forestry	0%	-	2%	-	3%	-	-	-	-	-	-	-	-		
Fisheries	0%	-	-	-	-	-	-	-	-	2%	-	-	-		
Mining	0%	-	-	-	3%	-	-	-	-	-	-	-	-		
Construction industry	6%	7%	11%	10%	21%	4%	8%	33%	33%	-	5%	5%	9%		
Manufacturing industry	10%	3%	5%	7%	16%	-	6%	33%	-	7%	10%	17%	9%		
Electricity, gas, heat supply, water supply	1%	1%	5%	3%	3%	-	5%	-	-	1%	-	2%	2%		
Information and communication industry	6%	8%	7%	10%	3%	-	4%	-	-	4%	11%	7%	2%		
Transportation industry	3%	1%	7%	-	6%	-	-	-	-	-	3%	3%	3%		
Wholesale / Retail	6%	1%	5%	3%	6%	-	42%	-	-	9%	9%	3%	11%		
Finance / Insurance	3%	3%	2%	7%	-	4%	-	-	-	1%	5%	2%	2%		
Real estate industry	4%	3%	9%	3%	4%	-	-	-	-	2%	3%	6%	3%		
Restaurant / accommodation business	4%	1%	-	3%	9%	22%	8%	-	-	4%	2%	2%	2%		
Medical and welfare	7%	12%	4%	7%	-	19%	-	-	-	6%	4%	6%	11%		
Education / learning support	14%	26%	18%	-	-	4%	-	-	33%	11%	10%	16%	14%		
Service industry (not classified elsewhere)	7%	5%	7%	10%	3%	11%	13%	-	33%	-	14%	10%	5%		
National institutions (those not classified elsewhere)	2%	4%	-	-	4%	-	-	-	-	2%	1%	2%	2%		
Local government (not classified elsewhere)	4%	4%	2%	7%	3%	-	-	-	-	2%	0%	3%	3%		
Others	21%	18%	14%	33%	18%	26%	13%	-	33%	50%	25%	15%	25%		
<b>Q7. Are you involved in work related to the health and of the company to which you operate or belong to?</b>															
Base	1005	202	56	30	34	27	24	3	3	54	250	174	65		
Directly involved	51%	48%	57%	37%	44%	63%	33%	33%	-	33%	68%	60%	60%		
Indirectly involved	36%	35%	39%	53%	29%	26%	46%	67%	67%	30%	21%	32%	35%		
Not involved	14%	17%	4%	10%	26%	11%	21%	-	33%	37%	11%	7%	5%		
<b>Q8. Please tell us about the number of employees of the company you operate or belong to.</b>															
Base	1005	202	56	30	34	27	24	3	3	54	250	174	65		
0 people	-	-	-	-	-	-	-	-	-	-	-	-	-		
1-9 people	29%	35%	32%	33%	59%	41%	33%	-	67%	63%	60%	26%	6%		
10-49 people	11%	6%	5%	27%	3%	7%	17%	33%	-	7%	12%	14%	14%		
50-99 people	10%	10%	5%	10%	12%	7%	4%	-	-	8%	9%	14%	9%		
100-499 people	19%	20%	13%	13%	-	11%	8%	33%	-	7%	12%	22%	34%		
500-999 people	6%	5%	9%	-	9%	15%	8%	-	-	4%	2%	10%	2%		
Over 1,000 people	25%	24%	36%	17%	18%	19%	29%	33%	33%	9%	7%	14%	35%		
Don't know	-	-	-	-	-	-	-	-	-	-	-	-	-		
<b>Q9. How much, if anything do you know about UK Health and Safety Law (the law, regulations, code of conduct, guidelines, etc.)?</b>															
Base	1005	202	56	30	34	27	24	3	3	54	250	174	65		
A great deal	14%	14%	13%	-	6%	7%	8%	-	-	4%	11%	19%	14%		
A fair amount	47%	42%	50%	50%	47%	44%	46%	67%	67%	30%	48%	45%	58%		
Only a little	30%	36%	34%	43%	29%	33%	25%	33%	-	34%	32%	29%	20%		
Hardly anything	8%	6%	4%	3%	18%	11%	21%	-	33%	24%	8%	6%	5%		
Nothing at all	2%	2%	-	3%	-	4%	-	-	-	6%	2%	1%	3%		
<b>Q10. When thinking about health and safety regulation in the UK, which of the following most closely resembles your view?</b>															
Base	610	113	35	15	18	14	13	2	2	18	147	112	47		
Too strict	11%	7%	9%	7%	6%	21%	23%	-	-	6%	13%	16%	19%		
Generally appropriate	79%	81%	80%	73%	78%	79%	62%	50%	100%	83%	78%	74%	70%		
Not strict enough	5%	7%	-	13%	6%	-	15%	-	-	-	3%	4%	6%		
It varies across different areas	6%	4%	11%	7%	11%	-	-	50%	-	11%	6%	6%	4%		
<b>Q11. Still thinking about health and safety regulation in the UK, which of the following most closely resembles your view?</b>															
Base	610	113	35	15	18	14	13	2	2	18	147	112	47		
Regulation is easy to understand and implement	23%	20%	14%	27%	39%	29%	23%	50%	-	17%	24%	21%	26%		
There are some aspects that are difficult to understand, but it can be implemented with guidance	72%	75%	80%	73%	50%	71%	77%	-	100%	83%	69%	73%	72%		
It is too complicated to understand and implement	5%	4%	6%	-	11%	-	-	-	-	7%	5%	2%	2%		
<b>Q12. Since the current Health and Safety at Work Act (HSWA) was enacted in 1974, the number of fatal-injuries in the UK has decreased by more than 80%. What, if anything, do you see as the main reason(s) for this? Please select all that apply</b>															
Base	1005	202	56	30	34	27	24	3	3	54	250	174	65		
Comprehensive hazard prevention standards (i.e. standards that clearly indicate what should be done and what should not be done)	48%	47%	38%	43%	59%	48%	54%	33%	33%	35%	46%	50%	49%		
Implementation of a health and safety management system (e.g. the appointment of a health and safety manager)	51%	47%	54%	50%	41%	59%	63%	67%	33%	35%	44%	42%	55%		
Better cooperation and coordination when multiple employers carry out construction at the same location	20%	19%	27%	23%	26%	15%	33%	-	-	24%	19%	17%	20%		
Stronger voluntary efforts of staff and management towards health and safety within the workplace	31%	29%	29%	27%	35%	30%	42%	67%	-	17%	33%	34%	23%		
Allowing businesses sufficient freedoms to enact their own changes	10%	7%	5%	10%	12%	11%	21%	-	-	11%	11%	13%	5%		
Easy to understand the relationship between laws, regulations, code of conduct, and guidance	17%	16%	16%	10%	15%	26%	21%	-	-	20%	16%	17%	26%		



**Kindai University Osaka**  
**Health & Safety survey**

Fieldwork Dates: 9th - 18th December 2020



	Total	Occupation									Company/Organisation Manager	Executive/Board Member	Middle Manager (in HRM division)
		Professional occupations	Associate professional and technical occupations	Administrative and secretarial occupations	Skilled trades occupations	Caring, leisure and other service occupations	Sales and customer service occupations	Process, plant and machine operatives	Elementary occupations	Other			
So-called three-step approach (First, take essential safety measures, second, take engineering measures for risks that cannot be dealt with by that, and third, take human measures such as education for the remaining risks to prevent industrial accidents) is employed	30%	30%	23%	10%	32%	26%	33%	-	33%	28%	28%	30%	29%
Employer liability	54%	52%	57%	63%	59%	59%	50%	67%	33%	52%	52%	54%	43%
Potential fines for employees who breach regulations	32%	33%	30%	27%	35%	30%	42%	-	33%	28%	29%	31%	31%
Measures to prevent occupational accidents (providing safe products, providing information on risks, etc.) are passed throughout the supply chain	52%	51%	50%	37%	62%	56%	58%	33%	-	37%	52%	51%	49%
There is an evaluation and registration system for machinery and chemical substances treated in workplaces	26%	26%	23%	20%	38%	26%	29%	33%	-	22%	24%	25%	22%
Realistic and well-balanced regulations	28%	31%	25%	33%	26%	26%	33%	33%	33%	20%	29%	26%	28%
Under this law, the HSE (Health and Safety Executive) has implemented appropriate health and safety guidance based on high expertise	43%	47%	32%	53%	50%	56%	46%	-	67%	31%	42%	37%	48%
Regular inspections and guidance from independent health and safety inspectors	37%	40%	32%	27%	35%	48%	46%	33%	33%	33%	30%	31%	40%
Under this law, a safety representative has supported the health and safety management of employers	23%	24%	21%	13%	26%	11%	25%	-	-	15%	20%	25%	26%
Fines being issued to employers in the past	29%	30%	32%	30%	24%	33%	29%	-	-	37%	29%	29%	22%
Potential fines for senior management if regulations are violated	38%	36%	48%	43%	35%	41%	42%	33%	-	30%	34%	40%	31%
Other	4%	4%	4%	-	3%	-	4%	33%	33%	7%	5%	6%	2%
Don't know	8%	9%	7%	-	12%	4%	8%	-	-	30%	9%	5%	3%

**Q13. When thinking about potential changes to the current Health and Safety at Work Act, which of the following issues, if any, do you think need greater focus?**

	Base	1005	202	56	30	34	27	24	3	3	54	250	174	65
A stronger definition of 'welfare' in the legal context	23%	24%	30%	23%	29%	33%	25%	-	-	33%	17%	19%	20%	17%
A stronger definition of 'reasonable practicable' in the legal context	27%	29%	32%	23%	26%	30%	13%	33%	33%	17%	24%	22%	26%	
Legal nature of the Code of Conduct (ACOP)	11%	12%	23%	10%	15%	4%	13%	-	-	4%	8%	11%	6%	
A stronger definition of legal obligations imposed on stakeholders (e.g. managers, designers, manufacturers)	23%	20%	29%	10%	26%	19%	13%	-	33%	13%	23%	21%	20%	
Stronger definition of risk for those working in spaces where harmful substances are handled	14%	13%	13%	13%	26%	7%	25%	-	-	20%	16%	12%	12%	
Stronger assessment of risks posed to workers dealing with chemical substances	19%	22%	23%	17%	26%	22%	33%	-	33%	17%	19%	16%	25%	
Stronger management of risks posed to workers dealing with chemical substances (e.g. controlling exposure)	19%	19%	21%	17%	35%	26%	25%	-	33%	20%	15%	11%	28%	
Measures to raise management awareness of health and safety regardless of business scale	28%	28%	21%	13%	18%	19%	38%	33%	-	15%	28%	25%	23%	
Current status/ importance placed on safety specialists in companies and society and measures to improve them	11%	11%	14%	13%	18%	7%	-	-	-	4%	9%	9%	9%	
Current status/ importance placed on hygiene specialists in companies and society and measures to improve them	9%	10%	14%	17%	21%	15%	4%	-	33%	4%	10%	6%	12%	
The appointment of an industrial physician be required by law	5%	7%	2%	3%	15%	-	8%	-	2%	2%	4%	5%	8%	
Introduction of mandatory health checks	17%	21%	16%	27%	24%	26%	13%	33%	-	11%	11%	16%	15%	
How to control the safety and health risks of older employees	17%	18%	21%	13%	18%	19%	21%	33%	-	22%	14%	13%	15%	
Measures to promote cooperation between community and occupational health management	11%	14%	11%	27%	6%	7%	13%	-	33%	7%	11%	11%	9%	
How safety and health laws and regulations should be for self-employed people such as cloud workers and freelancers	24%	25%	34%	33%	24%	22%	25%	33%	33%	19%	25%	21%	20%	
Stronger definition on health and safety laws for mobile workers	21%	23%	21%	13%	21%	22%	21%	-	33%	15%	18%	21%	18%	
Greater focus on employee mental health	40%	48%	36%	40%	26%	30%	38%	67%	67%	28%	33%	33%	37%	
Greater importance of Health and Safety Law in civil cases	12%	13%	16%	13%	15%	19%	13%	-	9%	12%	9%	12%	12%	
Other	4%	5%	5%	-	6%	-	4%	-	-	6%	3%	9%	-	
Don't know	21%	17%	14%	23%	21%	30%	25%	-	33%	43%	23%	22%	14%	

**Q14. How much importance do you place on health and safety in management?**

	Base	424	58	18	5	12	7	5	1	-	14	250	174	-
Very important	67%	59%	67%	40%	58%	86%	60%	-	-	64%	68%	67%	-	
Moderately important	25%	33%	22%	40%	33%	14%	40%	100%	-	24%	26%	-		
Neutral	6%	7%	11%	20%	-	-	-	-	-	7%	6%	5%	-	
Not very important	1%	-	-	-	-	-	-	-	-	-	2%	1%	-	
Not at all important	1%	2%	-	-	8%	-	-	-	-	-	1%	1%	-	

**Q15. You say that health and safety in management is important. Why do you say this? Please select up to three reasons.**

	Base	390	53	16	4	11	7	5	1	-	13	229	161	-
I do not want the emotional toll of being responsible for an accident	52%	53%	56%	100%	18%	71%	40%	100%	-	62%	55%	47%	-	
An accident could lead to paying a large compensation	24%	15%	38%	50%	18%	29%	20%	-	-	8%	21%	28%	-	
An accident could negatively affect company morale	36%	40%	13%	50%	45%	29%	20%	-	-	-	35%	39%	-	
An accident could negatively affect my company's reputation	47%	49%	44%	25%	18%	43%	60%	-	-	46%	45%	52%	-	
It is the company policy	27%	25%	38%	25%	27%	-	20%	-	-	15%	25%	29%	-	
The company has experienced a major industrial accident before	3%	2%	-	-	-	-	-	-	-	-	3%	4%	-	
I could be punished for violating the law	27%	15%	56%	-	27%	43%	60%	100%	-	46%	28%	26%	-	
An accident could lead to more absenteeism from employees	17%	19%	13%	-	9%	29%	40%	100%	-	16%	19%	-	-	
Other	14%	17%	6%	-	27%	-	20%	-	-	15%	13%	16%	-	

**Q16. In your approach to health and safety, which of the following measures, if any, are you currently taking? Please select up to three.**

	Base	127	11	3	1	-	-	-	-	-	1	48	79	-
We have dedicated senior managers in charge of health and safety	67%	45%	100%	-	-	-	-	-	-	-	-	71%	65%	-
We offer generous remuneration for health and safety specialists	13%	9%	33%	-	-	-	-	-	-	-	-	10%	14%	-
A department in charge of safety and health has been set up, and one or more staff members are assigned for every 100 employees	22%	27%	33%	-	-	-	-	-	-	-	-	27%	19%	-
We respect the authority of the health and safety specialists within the business	66%	73%	-	100%	-	-	-	-	-	-	-	63%	68%	-
The staff assigned to the department in charge of safety and health is reassigned to a central department (personnel department or business management department) of the company or appointed as an officer	33%	36%	33%	-	-	-	-	-	-	-	-	33%	33%	-
Other	5%	-	-	-	-	-	-	-	-	-	-	4%	5%	-
None of these	5%	9%	-	-	-	-	-	-	-	100%	-	2%	6%	-

**Q17. In your approach to health and safety, which of the following measures, if any, are you currently taking? Please select up to three.**

	Base	263	42	13	3	11	7	5	1	-	12	181	82	-
We have a health and safety committee	16%	14%	15%	-	9%	-	-	-	100%	-	-	13%	23%	-
An independent health and safety expert is invited to participate in the health and safety committee	11%	10%	-	-	9%	-	-	-	100%	-	-	12%	9%	-
A health and safety assistant has been appointed within the company	28%	29%	8%	-	9%	14%	20%	-	-	8%	-	25%	34%	-
We have commissioned an external health and safety consultant to conduct a workplace assessment and issue guidance	22%	19%	-	-	9%	-	-	-	100%	-	-	18%	30%	-
Other	10%	12%	15%	-	36%	14%	40%	-	-	8%	-	12%	7%	-
None of these	37%	38%	62%	100%	45%	71%	40%	-	-	83%	-	41%	27%	-

**Q18. You say that health and safety in management is not important. Why do you say this? Please select up to 3 reasons.**

	Base	10	1	-	-	1	-	-	-	-	-	6	4	-
We believe accidents are inevitable in the workplace and cannot be prevented	30%	100%	-	-	-	-	-	-	-	-	-	17%	50%	-
In the event of an accident, it is unlikely we will be required to pay compensation	30%	-	-	-	100%	-	-	-	-	-	-	17%	50%	-
In the event of an accident, it is unlikely to negatively affect staff morale	10%	-	-	-	-	-	-	-	-	-	-	-	25%	-
In the event of an accident, our reputation will not suffer	20%	-	-	-	-	-	-	-	-	-	-	17%	25%	-
Staff do not place importance on health and safety	-	-	-	-	-	-	-	-	-	-	-	-	-	-
Because the current top management does not place much importance to it	-	-	-	-	-	-	-	-	-	-	-	-	-	-
Because previous top management did not place much importance to it	-	-	-	-	-	-	-	-	-	-	-	-	-	-
Because the company has hardly / never experienced an accident	40%	-	-	-	-	-	-	-	-	-	-	33%	50%	-
Even if it is punished by law, it will not be a big disadvantage	20%	-	-	-	-	-	-	-	-	-	-	-	50%	-
Other	20%	-	-	-	-	-	-	-	-	-	-	33%	-	-

**Kindai University Osaka**  
**Health & Safety survey**

Fieldwork Dates: 9th - 18th December 2020



	Total	Position							Agriculture	Forestry	Fisheries	Mining	Construction industry
		Middle Manager (in other than HRM division)	Professionals (other than safety and health related)	Professionals (safety and health related)	Subordinate (in HRM division)	Subordinate (in other than HRM division)	Others	Not applicable - I don't have any management responsibility					
<b>Q1. Please answer your gender</b>													
Base	1005	273	112	36	2	6	60	27	9	2	1	1	56
Male	62%	55%	63%	81%	-	67%	63%	59%	67%	100%	100%	100%	68%
Female	38%	45%	38%	19%	100%	33%	37%	41%	33%	-	-	-	32%
<b>Q2. Age</b>													
Base	1005	273	112	36	2	6	60	27	9	2	1	1	56
20s	3%	8%	4%	3%	-	-	-	-	-	-	-	-	2%
30s	18%	25%	21%	19%	-	33%	13%	15%	-	50%	-	-	21%
40s	24%	25%	24%	11%	50%	-	25%	22%	11%	-	-	-	21%
50s	33%	32%	25%	42%	50%	33%	30%	22%	33%	50%	100%	100%	30%
60s and over	22%	11%	25%	25%	-	33%	32%	41%	56%	-	-	-	25%
<b>Q3. Nation</b>													
Base	1005	273	112	36	2	6	60	27	9	2	1	1	56
England	85%	83%	81%	89%	50%	67%	83%	85%	89%	50%	-	100%	79%
Wales	3%	5%	5%	3%	50%	-	7%	4%	-	50%	-	-	2%
Scotland	10%	12%	11%	6%	-	33%	8%	7%	11%	-	100%	-	20%
Northern Ireland	2%	1%	3%	3%	-	-	2%	4%	-	-	-	-	-
<b>Q4. Please answer your occupation.</b>													
Base	1005	273	112	36	2	6	60	27	9	2	1	1	56
Managers, executives and senior officials	57%	64%	19%	39%	50%	33%	20%	7%	11%	-	-	-	38%
Professional occupations	20%	14%	5%	36%	-	17%	10%	41%	33%	-	-	-	25%
Associate professional and technical occupations	6%	4%	13%	17%	-	-	5%	-	11%	50%	-	-	11%
Administrative and secretarial occupations	3%	5%	1%	-	50%	-	8%	4%	-	-	-	-	5%
Skilled trades occupations	3%	1%	4%	-	-	17%	12%	15%	22%	50%	-	100%	13%
Caring, leisure and other service occupations	3%	4%	1%	-	-	17%	8%	4%	11%	-	-	-	2%
Sales and customer service occupations	2%	3%	3%	3%	-	-	5%	7%	-	-	-	-	4%
Process, plant and machine operatives	0%	0%	1%	-	-	-	-	-	-	-	-	-	2%
Elementary occupations	0%	-	1%	-	-	-	2%	-	-	-	-	-	2%
Other	5%	3%	4%	6%	-	17%	30%	19%	11%	-	100%	-	-
Not Applicable - I don't work	0%	-	-	-	-	-	-	4%	-	-	-	-	-
<b>Q5. Please tell us about your position within the company you operate or belong to.</b>													
Base	1005	273	112	36	2	6	60	27	9	2	1	1	56
Company/Organization Manager	25%	-	-	-	-	-	-	-	33%	-	-	-	21%
Executive/Board Member	17%	-	-	-	-	-	-	-	11%	-	-	-	14%
Middle Manager (in HRM division)	6%	-	-	-	-	-	-	-	-	-	-	-	11%
Middle Manager (in other than HRM division)	27%	100%	-	-	-	-	-	-	11%	-	100%	-	13%
Professionals (other than safety and health related)	11%	-	100%	-	-	-	-	-	22%	50%	-	-	25%
Professionals (safety and health related)	4%	-	-	100%	-	-	-	-	-	-	-	-	5%
Subordinate (in HRM division)	0%	-	-	-	100%	-	-	-	-	-	-	-	-
Subordinate (in other than HRM division)	1%	-	-	-	-	100%	-	-	-	50%	-	-	-
Others	6%	-	-	-	-	-	100%	-	22%	-	-	-	9%
Not applicable - I don't have any management responsibility.	3%	-	-	-	-	-	-	100%	-	-	-	-	2%
<b>Q6. Please tell us about the type of business of the company you operate or belong to. If there are multiple applicable industries, please answer the one that you are mainly involved in.</b>													
Base	1005	273	112	36	2	6	60	27	9	2	1	1	56
Agriculture	1%	0%	2%	-	-	-	3%	-	100%	-	-	-	-
Forestry	0%	-	1%	-	-	17%	-	-	-	100%	-	-	-
Fisheries	0%	0%	-	-	-	-	-	-	-	-	100%	-	-
Mining	0%	-	-	-	-	-	-	4%	-	-	-	100%	-
Construction industry	6%	3%	13%	8%	-	-	8%	4%	-	-	-	-	100%
Manufacturing industry	10%	11%	4%	11%	-	-	5%	7%	-	-	-	-	-
Electricity, gas, heat supply, water supply	1%	1%	3%	8%	-	-	3%	26%	11%	50%	-	-	21%
Information and communication industry	6%	3%	6%	-	-	-	8%	7%	-	-	-	-	-
Transportation industry	3%	3%	4%	6%	-	-	-	4%	-	-	-	-	-
Wholesale / Retail	6%	5%	4%	3%	-	17%	8%	4%	-	-	-	-	-
Finance / Insurance	3%	3%	4%	3%	-	17%	2%	4%	-	-	-	-	-
Real estate industry	4%	6%	3%	3%	-	17%	-	-	-	-	-	-	-
Restaurant / accommodation business	4%	7%	3%	-	-	17%	8%	-	-	-	-	-	-
Medical and welfare	7%	8%	10%	14%	-	17%	3%	15%	-	-	-	-	-
Education / learning support	14%	17%	21%	14%	50%	-	7%	15%	-	-	-	-	-
Service industry (not classified elsewhere)	7%	5%	-	3%	-	-	5%	4%	-	-	-	-	-
National institutions (those not classified elsewhere)	2%	4%	2%	-	-	-	-	-	-	-	-	-	-
Local government (not classified elsewhere)	4%	5%	5%	8%	-	-	3%	4%	-	-	-	-	-
Others	21%	18%	15%	19%	50%	-	38%	30%	-	-	-	-	-
<b>Q7. Are you involved in work related to the health and of the company to which you operate or belong to?</b>													
Base	1005	273	112	36	2	6	60	27	9	2	1	1	56
Directly involved	51%	38%	31%	89%	50%	17%	30%	19%	44%	50%	-	-	71%
Indirectly involved	36%	49%	49%	11%	50%	50%	35%	26%	11%	50%	100%	100%	21%
Not involved	14%	13%	20%	-	-	33%	35%	56%	44%	-	-	-	7%
<b>Q8. Please tell us about the number of employees of the company you operate or belong to.</b>													
Base	1005	273	112	36	2	6	60	27	9	2	1	1	56
0 people	-	-	-	-	-	-	-	-	-	-	-	-	-
1-9 people	29%	5%	22%	6%	-	33%	60%	52%	78%	-	-	100%	32%
10-49 people	11%	11%	6%	-	-	-	8%	7%	-	-	-	-	9%
50-99 people	10%	11%	13%	17%	-	17%	2%	4%	11%	-	-	-	11%
100-499 people	19%	25%	19%	11%	50%	-	3%	19%	11%	-	-	-	23%
500-999 people	6%	9%	10%	8%	50%	-	3%	-	-	50%	100%	-	5%
Over 1,000 people	25%	39%	29%	58%	-	50%	23%	19%	-	50%	-	-	20%
Don't know	-	-	-	-	-	-	-	-	-	-	-	-	-
<b>Q9. How much, if anything do you know about UK Health and Safety Law (the law, regulations, code of conduct, guidelines, etc.)?</b>													
Base	1005	273	112	36	2	6	60	27	9	2	1	1	56
A great deal	14%	11%	8%	72%	50%	17%	5%	4%	11%	-	-	-	27%
A fair amount	47%	49%	54%	22%	50%	50%	25%	41%	44%	100%	-	100%	50%
Only a little	30%	32%	31%	3%	-	33%	40%	26%	44%	-	100%	-	23%
Hardly anything	8%	6%	5%	3%	-	-	25%	26%	-	-	-	-	-
Nothing at all	2%	1%	2%	-	-	-	5%	4%	-	-	-	-	-
<b>Q10. When thinking about health and safety regulation in the UK, which of the following most closely resembles your view?</b>													
Base	610	165	69	34	2	4	18	12	5	2	-	1	43
Too strict	11%	5%	9%	3%	-	25%	33%	-	20%	-	-	-	9%
Generally appropriate	79%	86%	86%	74%	100%	25%	50%	92%	80%	-	-	100%	79%
Not strict enough	5%	5%	1%	12%	-	25%	11%	-	-	-	-	-	-
It varies across different areas	6%	4%	4%	12%	-	25%	6%	8%	-	100%	-	-	12%
<b>Q11. Still thinking about health and safety regulation in the UK, which of the following most closely resembles your view?</b>													
Base	610	165	69	34	2	4	18	12	5	2	-	1	43
Regulation is easy to understand and implement	23%	20%	23%	29%	50%	-	28%	17%	40%	-	-	-	35%
There are some aspects that are difficult to understand, but it can be implemented with guidance	72%	75%	72%	71%	50%	75%	67%	83%	60%	50%	-	100%	63%
It is too complicated to understand and implement	5%	5%	4%	-	-	25%	6%	-	-	50%	-	-	2%
<b>Q12. Since the current Health and Safety at Work Act (HSWA) was enacted in 1974, the number of fatal-injuries in the UK has decreased by more than 80%. What, if anything, do you see as the main reason(s) for this? Please select all that apply</b>													
Base	1005	273	112	36	2	6	60	27	9	2	1	1	56
Comprehensive hazard prevention standards (i.e. standards that clearly indicate what should be done and what should not be done)	48%	53%	46%	47%	50%	50%	35%	48%	44%	50%	-	-	45%
Implementation of a health and safety management system (e.g. the appointment of a health and safety manager)	51%	60%	54%	72%	100%	17%	47%	41%	22%	50%	100%	-	46%
Better cooperation and coordination when multiple employers carry out construction at the same location	20%	18%	22%	33%	-	-	33%	19%	11%	-	-	-	32%
Stronger voluntary efforts of staff and management towards health and safety within the workplace	31%	26%	32%	42%	50%	50%	28%	30%	22%	50%	-	-	27%
Allowing businesses sufficient freedoms to enact their own changes	10%	9%	7%	6%	-	17%	10%	11%	11%	-	-	-	9%
Easy to understand the relationship between laws, regulations, code of conduct, and guidance	17%	17%	17%	17%	-	17%	18%	15%	22%	50%	-	-	11%



	Total	Position							Agriculture	Forestry	Fisheries	Mining	Construction industry
		Middle Manager (in other than HRM division)	Professionals (other than safety and health related)	Professionals (safety and health related)	Subordinate (in HRM division)	Subordinate (in other than HRM division)	Others	Not applicable - I don't have any management responsibility					
So-called three-step approach (First, take essential safety measures, second, take engineering measures for risks that cannot be dealt with by that, and third, take human measures such as education for the remaining risks to prevent industrial accidents) is employed	30%	30%	32%	44%	50%	50%	20%	26%	33%	50%	-	-	30%
Employer liability	54%	56%	59%	58%	100%	83%	53%	48%	22%	50%	100%	-	43%
Potential fines for employees who breach regulations	32%	33%	33%	44%	50%	33%	28%	26%	11%	-	-	-	27%
Measures to prevent occupational accidents (providing safe products, providing information on risks, etc.) are passed throughout the supply chain	52%	53%	57%	50%	100%	67%	40%	44%	44%	50%	-	100%	50%
There is an evaluation and registration system for machinery and chemical substances treated in workplace	26%	29%	33%	19%	50%	33%	25%	22%	33%	50%	-	-	18%
Realistic and well-balanced regulations	28%	26%	28%	39%	50%	17%	32%	33%	33%	-	-	-	27%
Under this law, the HSE (Health and Safety Executive) has implemented appropriate health and safety guidance based on high expertise	43%	45%	45%	61%	100%	33%	38%	52%	33%	-	-	100%	36%
Regular inspections and guidance from independent health and safety inspectors	37%	43%	37%	36%	-	67%	35%	56%	33%	50%	-	100%	32%
Under this law, a safety representative has supported the health and safety management of employers	23%	23%	27%	25%	-	33%	20%	26%	11%	-	-	-	11%
Fines being issued to employees in the past	29%	28%	30%	42%	50%	50%	30%	26%	22%	100%	100%	-	16%
Potential fines for senior management if regulations are violated	38%	42%	37%	47%	50%	50%	32%	33%	33%	100%	100%	-	32%
Other	4%	1%	4%	6%	-	-	5%	4%	11%	-	-	-	7%
Don't know	8%	6%	5%	-	-	-	25%	22%	11%	-	-	-	5%
<b>Q13. When thinking about potential changes to the current Health and Safety at Work Act, which of the following issues, if any, do you think need greater focus?</b>													
Base	1005	273	112	36	2	6	60	27	9	2	1	1	56
A stronger definition of 'welfare' in the legal context	23%	27%	27%	36%	50%	33%	20%	15%	22%	50%	100%	-	30%
A stronger definition of 'reasonable practicable' in the legal context	27%	32%	29%	50%	-	33%	18%	19%	11%	50%	100%	-	23%
Legal nature of the Code of Conduct (ACOP)	11%	12%	19%	19%	50%	17%	8%	4%	11%	50%	-	-	11%
A stronger definition of legal obligations imposed on stakeholders (e.g. managers, designers, manufacturers)	23%	23%	21%	53%	-	50%	17%	7%	11%	50%	-	-	21%
Stronger definition of risk for those working in spaces where harmful substances are handled	14%	12%	13%	8%	-	33%	25%	11%	11%	50%	-	-	14%
Stronger assessment of risks posed to workers dealing with chemical substances	19%	15%	26%	14%	-	83%	30%	19%	22%	50%	-	-	23%
Stronger management of risks posed to workers dealing with chemical substances (e.g. controlling exposure)	19%	19%	25%	17%	-	33%	32%	26%	33%	50%	-	-	20%
Measures to raise management awareness of health and safety regardless of business scale	28%	33%	26%	42%	50%	50%	18%	22%	11%	-	100%	-	30%
Current status/ importance placed on safety specialists in companies and society and measures to improve them	11%	11%	9%	31%	50%	17%	10%	19%	11%	-	-	100%	13%
Current status/ importance placed on hygiene specialists in companies and society and measures to improve them	9%	8%	6%	11%	50%	-	10%	11%	33%	-	-	-	5%
The appointment of an industrial physician is required by law	5%	6%	2%	14%	-	33%	7%	-	11%	50%	-	-	7%
Introduction of mandatory health checks	17%	19%	24%	17%	-	33%	17%	19%	11%	-	-	-	14%
How to control the safety and health risks of older employees	17%	20%	19%	17%	50%	50%	20%	19%	11%	50%	100%	-	9%
Measures to promote cooperation between community and occupational health management	11%	12%	11%	8%	50%	17%	10%	11%	11%	-	-	100%	13%
How safety and health laws and regulations should be for self-employed people such as cloud workers and freelancers	24%	22%	28%	42%	100%	17%	20%	33%	22%	50%	-	-	27%
Stronger definition on health and safety laws for mobile workers	21%	22%	26%	31%	50%	33%	13%	22%	11%	-	-	-	13%
Greater focus on employee mental health	40%	46%	52%	53%	100%	50%	27%	41%	11%	50%	100%	-	45%
Greater importance of Health and Safety Law in civil cases	12%	12%	15%	11%	50%	17%	15%	7%	22%	-	-	-	9%
Other	4%	2%	4%	8%	-	-	3%	4%	11%	50%	-	-	5%
Don't know	21%	16%	15%	6%	-	17%	52%	30%	44%	-	-	-	11%
<b>Q14. How much importance do you place on health and safety in management?</b>													
Base	424	-	-	-	-	-	-	-	4	-	-	-	20
Very important	67%	-	-	-	-	-	-	-	75%	-	-	-	65%
Moderately important	25%	-	-	-	-	-	-	-	25%	-	-	-	35%
Neutral	6%	-	-	-	-	-	-	-	-	-	-	-	-
Not very important	1%	-	-	-	-	-	-	-	-	-	-	-	-
Not at all important	1%	-	-	-	-	-	-	-	-	-	-	-	-
<b>Q15. You say that health and safety in management is important. Why do you say this? Please select up to three reasons.</b>													
Base	390	-	-	-	-	-	-	-	4	-	-	-	20
I do not want the emotional toll of being responsible for an accident	52%	-	-	-	-	-	-	-	25%	-	-	-	45%
An accident could lead to paying a large compensation	24%	-	-	-	-	-	-	-	25%	-	-	-	20%
An accident could negatively affect company morale	36%	-	-	-	-	-	-	-	50%	-	-	-	45%
An accident could negatively affect my company's reputation	47%	-	-	-	-	-	-	-	50%	-	-	-	35%
It is the company policy	27%	-	-	-	-	-	-	-	25%	-	-	-	25%
The company has experienced a major industrial accident before	3%	-	-	-	-	-	-	-	-	-	-	-	10%
I could be punished for violating the law	27%	-	-	-	-	-	-	-	25%	-	-	-	20%
An accident could lead to more absenteeism from employees	17%	-	-	-	-	-	-	-	-	-	-	-	20%
Other	14%	-	-	-	-	-	-	-	25%	-	-	-	20%
<b>Q16. In your approach to health and safety, which of the following measures, if any, are you currently taking? Please select up to three.</b>													
Base	127	-	-	-	-	-	-	-	-	-	-	-	9
We have dedicated senior managers in charge of health and safety	67%	-	-	-	-	-	-	-	-	-	-	-	67%
We offer generous remuneration for health and safety specialists	13%	-	-	-	-	-	-	-	-	-	-	-	22%
A department in charge of safety and health has been set up, and one or more staff members are assigned for every 100 employees	22%	-	-	-	-	-	-	-	-	-	-	-	22%
We respect the authority of the health and safety specialists within the business	66%	-	-	-	-	-	-	-	-	-	-	-	89%
The staff assigned to the department in charge of safety and health is reassigned to a central department (personnel department or business management department) of the company or appointed as an officer	33%	-	-	-	-	-	-	-	-	-	-	-	44%
Other	5%	-	-	-	-	-	-	-	-	-	-	-	-
None of these	5%	-	-	-	-	-	-	-	-	-	-	-	-
<b>Q17. In your approach to health and safety, which of the following measures, if any, are you currently taking? Please select up to three.</b>													
Base	263	-	-	-	-	-	-	-	4	-	-	-	11
We have a health and safety committee	16%	-	-	-	-	-	-	-	-	-	-	-	27%
An independent health and safety expert is invited to participate in the health and safety committee	11%	-	-	-	-	-	-	-	25%	-	-	-	9%
A health and safety assistant has been appointed within the company	28%	-	-	-	-	-	-	-	25%	-	-	-	18%
We have commissioned an external health and safety consultant to conduct a workplace assessment and issue guidance	22%	-	-	-	-	-	-	-	-	-	-	-	27%
Other	10%	-	-	-	-	-	-	-	25%	-	-	-	16%
None of these	37%	-	-	-	-	-	-	-	25%	-	-	-	27%
<b>Q18. You say that health and safety in management is not important. Why do you say this? Please select up to 3 reasons.</b>													
Base	10	-	-	-	-	-	-	-	-	-	-	-	-
We believe accidents are inevitable in the workplace and cannot be prevented	30%	-	-	-	-	-	-	-	-	-	-	-	-
In the event of an accident, it is unlikely we will be required to pay compensation	30%	-	-	-	-	-	-	-	-	-	-	-	-
In the event of an accident, it is unlikely to negatively affect staff morale	10%	-	-	-	-	-	-	-	-	-	-	-	-
In the event of an accident, our reputation will not suffer	20%	-	-	-	-	-	-	-	-	-	-	-	-
Staff do not place importance on health and safety	-	-	-	-	-	-	-	-	-	-	-	-	-
Because the current top management does not place much importance to it	-	-	-	-	-	-	-	-	-	-	-	-	-
Because previous top management did not place much importance to it	-	-	-	-	-	-	-	-	-	-	-	-	-
Because the company has hardly / never experienced an accident	40%	-	-	-	-	-	-	-	-	-	-	-	-
Even if it is punished by law, it will not be a big disadvantage	20%	-	-	-	-	-	-	-	-	-	-	-	-
Other	20%	-	-	-	-	-	-	-	-	-	-	-	-

**Kindai University Osaka**  
**Health & Safety survey**

Fieldwork Dates: 9th - 18th December 2020



	Total	Industry											
		Manufacturing industry	Electricity, gas, heat supply, water supply	Information and communication industry	Transportation industry	Wholesale / Retail	Finance / Insurance	Real estate industry	Restaurant / accommodation business	Medical and welfare	Education / learning support	Service industry (not classified elsewhere)	National institutions (those not classified elsewhere)
<b>Q1. Please answer your gender</b>													
Base	1005	103	13	62	28	62	30	42	39	73	145	75	19
Male	62%	79%	100%	76%	75%	71%	67%	69%	44%	47%	61%	68%	68%
Female	38%	21%	-	24%	25%	29%	33%	31%	56%	53%	39%	32%	32%
<b>Q2. Age</b>													
Base	1005	103	13	62	28	62	30	42	39	73	145	75	19
20s	3%	2%	8%	3%	-	5%	3%	5%	21%	3%	-	8%	5%
30s	18%	17%	-	15%	-	27%	27%	12%	28%	26%	21%	7%	32%
40s	24%	21%	23%	24%	25%	18%	20%	29%	23%	21%	33%	23%	21%
50s	33%	38%	31%	29%	57%	31%	43%	31%	18%	30%	29%	44%	37%
60s and over	22%	22%	38%	29%	18%	19%	7%	24%	10%	21%	17%	19%	5%
<b>Q3. Nation</b>													
Base	1005	103	13	62	28	62	30	42	39	73	145	75	19
England	85%	86%	100%	82%	93%	85%	80%	83%	85%	81%	91%	85%	84%
Wales	3%	5%	-	3%	-	3%	-	3%	5%	3%	4%	5%	5%
Scotland	10%	6%	-	11%	4%	10%	13%	17%	10%	12%	5%	9%	11%
Northern Ireland	2%	3%	-	3%	4%	5%	3%	-	3%	1%	1%	1%	-
<b>Q4. Please answer your occupation.</b>													
Base	1005	103	13	62	28	62	30	42	39	73	145	75	19
Managers, executives and senior officials	57%	76%	54%	56%	68%	61%	60%	67%	62%	51%	51%	65%	47%
Professional occupations	20%	7%	15%	26%	11%	5%	2%	14%	3%	33%	17%	15%	42%
Associate professional and technical occupations	6%	3%	23%	6%	14%	5%	3%	12%	3%	7%	5%	5%	-
Administrative and secretarial occupations	3%	2%	-	5%	-	2%	7%	2%	3%	-	4%	-	-
Skilled trades occupations	3%	6%	8%	2%	7%	3%	-	8%	-	-	1%	-	-
Caring, leisure and other service occupations	3%	-	-	-	-	-	3%	2%	15%	7%	1%	4%	5%
Sales and customer service occupations	2%	2%	-	2%	-	16%	3%	-	5%	-	4%	-	-
Process, plant and machine operatives	0%	1%	-	-	-	-	-	-	-	-	1%	-	-
Elementary occupations	0%	-	-	-	-	-	-	-	-	-	1%	-	-
Other	5%	4%	-	3%	-	8%	-	2%	5%	4%	4%	-	5%
Not Applicable - I don't work	0%	-	-	-	-	-	-	-	-	-	-	-	-
<b>Q5. Please tell us about your position within the company you operate or belong to.</b>													
Base	1005	103	13	62	28	62	30	42	39	73	145	75	19
Company/Organization Manager	25%	23%	15%	44%	25%	37%	10%	19%	15%	14%	17%	48%	11%
Executive/Board Member	17%	28%	-	21%	18%	8%	27%	26%	10%	15%	19%	23%	16%
Middle Manager (in HRM division)	6%	6%	8%	2%	7%	11%	3%	5%	3%	10%	6%	4%	5%
Middle Manager (in other than HRM division)	27%	29%	31%	11%	25%	23%	30%	38%	49%	30%	32%	19%	58%
Professionals (other than safety and health related)	11%	5%	22%	11%	14%	8%	17%	7%	8%	15%	17%	3%	11%
Professionals (safety and health related)	4%	4%	22%	-	7%	2%	3%	2%	-	7%	3%	1%	-
Subordinate (in HRM division)	0%	-	-	-	-	-	-	-	-	-	1%	-	-
Subordinate (in other than HRM division)	1%	-	-	-	-	2%	3%	2%	3%	1%	-	-	-
Others	6%	3%	-	8%	-	8%	3%	-	13%	3%	3%	4%	-
Not applicable - I don't have any management responsibility.	3%	2%	-	3%	4%	2%	3%	-	-	5%	3%	1%	-
<b>Q6. Please tell us about the type of business of the company you operate or belong to. If there are multiple applicable industries, please answer the one that you are mainly involved in.</b>													
Base	1005	103	13	62	28	62	30	42	39	73	145	75	19
Agriculture	1%	-	-	-	-	-	-	-	-	-	-	-	-
Forestry	0%	-	-	-	-	-	-	-	-	-	-	-	-
Fisheries	0%	-	-	-	-	-	-	-	-	-	-	-	-
Mining	0%	-	-	-	-	-	-	-	-	-	-	-	-
Construction industry	6%	-	-	-	-	-	-	-	-	-	-	-	-
Manufacturing industry	10%	100%	-	-	-	-	-	-	-	-	-	-	-
Electricity, gas, heat supply, water supply	1%	-	100%	-	-	-	-	-	-	-	-	-	-
Information and communication industry	6%	-	-	100%	-	-	-	-	-	-	-	-	-
Transportation industry	3%	-	-	-	100%	-	-	-	-	-	-	-	-
Wholesale / Retail	6%	-	-	-	-	100%	-	-	-	-	-	-	-
Finance / Insurance	3%	-	-	-	-	-	100%	-	-	-	-	-	-
Real estate industry	4%	-	-	-	-	-	-	100%	-	-	-	-	-
Restaurant / accommodation business	4%	-	-	-	-	-	-	-	100%	-	-	-	-
Medical and welfare	7%	-	-	-	-	-	-	-	-	100%	-	-	-
Education / learning support	14%	-	-	-	-	-	-	-	-	-	100%	-	-
Service industry (not classified elsewhere)	7%	-	-	-	-	-	-	-	-	-	-	100%	-
National institutions (those not classified elsewhere)	2%	-	-	-	-	-	-	-	-	-	-	-	100%
Local government (not classified elsewhere)	4%	-	-	-	-	-	-	-	-	-	-	-	-
Others	21%	-	-	-	-	-	-	-	-	-	-	-	-
<b>Q7. Are you involved in work related to the health and of the company to which you operate or belong?</b>													
Base	1005	103	13	62	28	62	30	42	39	73	145	75	19
Directly involved	51%	51%	62%	55%	46%	47%	43%	55%	36%	55%	52%	64%	37%
Indirectly involved	36%	37%	38%	31%	39%	37%	37%	31%	38%	33%	38%	37%	42%
Not involved	14%	12%	-	15%	14%	16%	20%	14%	26%	12%	10%	9%	21%
<b>Q8. Please tell us about the number of employees of the company you operate or belong to.</b>													
Base	1005	103	13	62	28	62	30	42	39	73	145	75	19
0 people	-	-	-	-	-	-	-	-	-	-	-	-	-
1-9 people	29%	20%	31%	58%	14%	29%	30%	38%	15%	21%	11%	47%	5%
10-49 people	11%	15%	-	11%	7%	18%	3%	5%	6%	7%	10%	9%	5%
50-99 people	10%	14%	-	6%	11%	3%	12%	15%	12%	15%	16%	11%	-
100-499 people	19%	26%	22%	6%	25%	23%	10%	21%	13%	16%	30%	16%	5%
500-999 people	6%	9%	6%	6%	-	5%	7%	5%	10%	8%	8%	5%	5%
Over 1,000 people	25%	17%	38%	11%	43%	23%	37%	19%	38%	38%	24%	12%	79%
Don't know	-	-	-	-	-	-	-	-	-	-	-	-	-
<b>Q9. How much, if anything do you know about UK Health and Safety Law (the law, regulations, code of conduct, guidelines, etc.)?</b>													
Base	1005	103	13	62	28	62	30	42	39	73	145	75	19
A great deal	14%	16%	38%	11%	14%	15%	10%	14%	8%	12%	19%	16%	16%
A fair amount	47%	55%	46%	40%	46%	45%	43%	45%	54%	45%	49%	49%	32%
Only a little	30%	22%	8%	40%	25%	27%	40%	31%	23%	37%	32%	25%	42%
Hardly anything	8%	6%	-	8%	14%	10%	3%	10%	10%	10%	4%	5%	5%
Nothing at all	2%	1%	8%	-	-	3%	3%	-	5%	-	3%	1%	5%
<b>Q10. When thinking about health and safety regulation in the UK, which of the following most closely resembles your view?</b>													
Base	610	73	11	32	17	37	16	25	24	39	89	51	9
Too strict	11%	15%	-	22%	18%	14%	6%	20%	13%	18%	3%	16%	22%
Generally appropriate	79%	77%	82%	63%	82%	73%	75%	80%	75%	69%	92%	65%	78%
Not strict enough	5%	3%	-	9%	-	5%	13%	-	8%	8%	1%	14%	-
It varies across different areas	6%	5%	18%	6%	-	8%	6%	-	4%	5%	3%	6%	-
<b>Q11. Still thinking about health and safety regulation in the UK, which of the following most closely resembles your view?</b>													
Base	610	73	11	32	17	37	16	25	24	39	89	51	9
Regulation is easy to understand and implement	23%	21%	18%	19%	6%	24%	19%	16%	17%	23%	22%	22%	11%
There are some aspects that are difficult to understand, but it can be implemented with guidance	72%	71%	82%	72%	82%	73%	75%	76%	79%	72%	74%	71%	78%
It is too complicated to understand and implement	5%	8%	-	9%	12%	3%	6%	8%	4%	5%	3%	8%	11%
<b>Q12. Since the current Health and Safety at Work Act (HSWA) was enacted in 1974, the number of fatal-injuries in the UK has decreased by more than 80%. What, if anything, do you see as the main reason(s) for this? Please select all that apply</b>													
Base	1005	103	13	62	28	62	30	42	39	73	145	75	19
Comprehensive hazard prevention standards (i.e. standards that clearly indicate what should be done and what should not be done)	48%	45%	85%	39%	43%	52%	53%	45%	59%	45%	50%	39%	63%
Implementation of a health and safety management system (e.g. the appointment of a health and safety manager)	51%	53%	77%	32%	54%	53%	57%	52%	59%	47%	53%	37%	63%
Better cooperation and coordination when multiple employers carry out construction at the same location	20%	16%	46%	19%	21%	21%	23%	31%	18%	19%	19%	12%	26%
Stronger voluntary efforts of staff and management towards health and safety within the workplace	31%	31%	46%	24%	21%	34%	30%	29%	31%	38%	30%	36%	32%
Allowing businesses sufficient freedoms to enact their own changes	10%	15%	23%	11%	7%	13%	13%	10%	5%	8%	3%	15%	-
Easy to understand the relationship between laws, regulations, code of conduct, and guidance	17%	13%	46%	8%	16%	8%	17%	21%	21%	19%	17%	15%	21%

**Kindai University Osaka**  
**Health & Safety survey**

Fieldwork Dates: 9th - 18th December 2020



	Total	Industry												
		Manufacturing industry	Electricity, gas, heat supply, water supply	Information and communication industry	Transportation industry	Wholesale / Retail	Finance / Insurance	Real estate industry	Restaurant / accommodation business	Medical and welfare	Education / learning support	Service industry (not classified elsewhere)	National institutions (those not classified elsewhere)	
So-called three-step approach (First, take essential safety measures, second, take engineering measures for risks that cannot be dealt with by that, and third, take human measures such as education for the remaining risks to prevent industrial accidents) is employed	30%	31%	54%	26%	32%	37%	30%	26%	31%	26%	27%	23%	42%	
Employer liability	54%	43%	77%	60%	61%	63%	67%	55%	64%	52%	58%	44%	63%	
Potential fines for employees who breach regulations	32%	27%	46%	29%	36%	26%	37%	43%	44%	40%	26%	23%	37%	
Measures to prevent occupational accidents (providing safe products, providing information on risks, etc.) are passed throughout the supply chain	52%	46%	69%	42%	57%	47%	47%	55%	67%	49%	59%	45%	58%	
There is an evaluation and registration system for machinery and chemical substances treated in workplaces	26%	28%	38%	34%	32%	21%	20%	26%	36%	25%	23%	19%	42%	
Realistic and well-balanced regulations	28%	21%	38%	18%	32%	24%	27%	24%	36%	33%	28%	25%	21%	
Under this law, the HSE (Health and Safety Executive) has implemented appropriate health and safety guidance based on high expertise	43%	33%	62%	34%	50%	40%	47%	48%	54%	44%	42%	37%	53%	
Regular inspections and guidance from independent health and safety inspectors	37%	35%	62%	26%	43%	34%	43%	43%	49%	45%	33%	24%	37%	
Under this law, a safety representative has supported the health and safety management of employers	23%	23%	62%	19%	25%	18%	23%	31%	28%	29%	23%	17%	37%	
Fines being issued to employers in the past	29%	25%	54%	21%	32%	26%	43%	31%	41%	34%	28%	24%	32%	
Potential fines for senior management if regulations are violated	38%	32%	62%	29%	36%	26%	63%	52%	36%	40%	34%	35%	42%	
Other	4%	7%	15%	8%	-	3%	-	2%	-	3%	1%	4%	5%	
Don't know	8%	7%	-	11%	-	13%	-	5%	5%	7%	8%	4%	5%	
<b>Q13. When thinking about potential changes to the current Health and Safety at Work Act, which of the following issues, if any, do you think need greater focus?</b>	<b>Base</b>	1005	103	13	62	28	62	30	42	39	73	145	75	19
A stronger definition of 'welfare' in the legal context		23%	17%	31%	21%	21%	23%	30%	12%	31%	23%	24%	15%	32%
A stronger definition of 'reasonable practicable' in the legal context		27%	27%	54%	24%	32%	24%	23%	31%	18%	37%	25%	17%	26%
Legal nature of the Code of Conduct (ACOP)		11%	9%	31%	10%	7%	13%	13%	12%	13%	14%	12%	8%	16%
A stronger definition of legal obligations imposed on stakeholders (e.g. managers, designers, manufacturers)		23%	27%	46%	23%	36%	27%	40%	19%	10%	26%	19%	17%	21%
Stronger definition of risk for those working in spaces where harmful substances are handled		14%	12%	15%	19%	32%	21%	17%	12%	21%	12%	7%	9%	21%
Stronger assessment of risks posed to workers dealing with chemical substances		19%	26%	31%	19%	25%	26%	17%	14%	18%	23%	14%	16%	21%
Stronger management of risks posed to workers dealing with chemical substances (e.g. controlling exposure)		19%	23%	15%	23%	29%	24%	13%	26%	21%	22%	14%	12%	16%
Measures to raise management awareness of health and safety regardless of business scale		28%	25%	31%	26%	39%	32%	40%	26%	18%	33%	19%	29%	37%
Current status/ importance placed on safety specialists in companies and society and measures to improve them		11%	11%	8%	11%	14%	5%	27%	5%	8%	14%	7%	7%	21%
Current status/ importance placed on hygiene specialists in companies and society and measures to improve them		9%	11%	-	10%	18%	11%	23%	7%	8%	7%	5%	7%	21%
The appointment of an industrial physician be required by law		5%	6%	-	3%	4%	8%	10%	2%	8%	3%	3%	3%	21%
Introduction of mandatory health checks		17%	21%	8%	15%	14%	16%	23%	12%	26%	26%	14%	4%	21%
How to control the safety and health risks of older employees		17%	19%	8%	15%	18%	18%	17%	17%	10%	21%	15%	2%	21%
Measures to promote cooperation between community and occupational health management		11%	11%	8%	10%	11%	10%	13%	12%	15%	11%	7%	9%	21%
How safety and health laws and regulations should be for self-employed people such as cloud workers and freelancers		24%	18%	38%	37%	32%	18%	30%	31%	8%	30%	16%	20%	37%
Stronger definition on health and safety laws for mobile workers		21%	20%	46%	19%	32%	10%	23%	24%	21%	32%	14%	13%	37%
Greater focus on employee mental health		40%	34%	54%	32%	39%	31%	40%	29%	44%	52%	47%	32%	53%
Greater importance of Health and Safety Law in civil cases		12%	2%	8%	21%	7%	10%	23%	7%	5%	23%	7%	9%	16%
Other		4%	7%	23%	5%	-	2%	-	2%	-	4%	3%	7%	-
Don't know		21%	14%	-	32%	11%	24%	17%	21%	28%	12%	23%	17%	11%
<b>Q14. How much importance do you place on health and safety in management?</b>	<b>Base</b>	424	53	2	40	12	28	11	19	10	21	51	53	5
Very important		67%	72%	100%	45%	75%	57%	55%	79%	80%	62%	76%	58%	60%
Moderately important		25%	26%	-	33%	17%	36%	18%	16%	10%	24%	20%	30%	20%
Neutral		6%	-	-	20%	8%	4%	18%	5%	10%	14%	2%	8%	-
Not very important		1%	-	-	3%	-	-	9%	-	-	-	2%	4%	-
Not at all important		1%	2%	-	-	-	4%	-	-	-	-	-	-	20%
<b>Q15. You say that health and safety in management is important. Why do you say this? Please select up to three reasons.</b>	<b>Base</b>	390	52	2	31	11	26	8	18	9	18	49	47	4
I do not want the emotional toll of being responsible for an accident		52%	48%	50%	52%	64%	58%	50%	72%	78%	33%	57%	57%	25%
An accident could lead to paying a large compensation		24%	27%	-	13%	55%	35%	38%	39%	11%	22%	24%	21%	50%
An accident could negatively affect company morale		36%	48%	-	23%	18%	23%	13%	28%	56%	44%	39%	32%	100%
An accident could negatively affect my company's reputation		47%	42%	50%	42%	64%	42%	50%	39%	33%	67%	55%	51%	75%
It is the company policy		27%	35%	100%	35%	18%	23%	50%	17%	22%	11%	22%	26%	-
The company has experienced a major industrial accident before		3%	2%	-	3%	9%	-	13%	-	-	-	2%	2%	-
I could be punished for violating the law		27%	37%	-	16%	18%	35%	38%	39%	33%	44%	24%	32%	-
An accident could lead to more absenteeism from employees		17%	17%	50%	19%	36%	19%	-	22%	11%	33%	20%	11%	25%
Other		14%	6%	50%	29%	9%	15%	13%	6%	-	11%	14%	2%	-
<b>Q16. In your approach to health and safety, which of the following measures, if any, are you currently taking? Please select up to three.</b>	<b>Base</b>	127	19	-	7	4	5	3	5	4	7	25	14	2
We have dedicated senior managers in charge of health and safety		67%	68%	-	57%	75%	60%	33%	80%	75%	71%	64%	64%	50%
We offer generous remuneration for health and safety specialists		13%	5%	-	43%	-	20%	33%	-	50%	-	-	21%	-
A department in charge of safety and health has been set up, and one or more staff members are assigned for every 100 employees		22%	26%	-	43%	50%	20%	33%	40%	-	14%	28%	7%	50%
We respect the authority of the health and safety specialists within the business		66%	74%	-	57%	50%	40%	100%	60%	75%	57%	64%	50%	50%
The staff assigned to the department in charge of safety and health is reassigned to a central department (personnel department or business management department) of the company or appointed as an officer		33%	21%	-	43%	50%	40%	67%	20%	50%	29%	20%	36%	50%
Other		5%	11%	-	-	25%	-	-	-	-	-	-	-	-
None of these		5%	5%	-	-	-	-	-	20%	-	14%	8%	-	-
<b>Q17. In your approach to health and safety, which of the following measures, if any, are you currently taking? Please select up to three.</b>	<b>Base</b>	263	33	2	24	7	21	5	13	5	11	24	33	2
We have a health and safety committee		16%	30%	-	17%	14%	14%	40%	-	20%	9%	21%	18%	-
An independent health and safety expert is invited to participate in the health and safety committee.		11%	6%	-	4%	14%	24%	20%	-	-	18%	21%	12%	-
A health and safety assistant has been appointed within the company		28%	30%	50%	25%	29%	33%	60%	23%	40%	9%	42%	30%	50%
We have commissioned an external health and safety consultant to conduct a workplace assessment and issue guidance		22%	30%	-	13%	57%	29%	-	31%	-	18%	29%	18%	-
Other		10%	3%	50%	13%	14%	10%	20%	8%	20%	-	4%	6%	-
None of these		37%	36%	-	46%	29%	33%	20%	38%	20%	55%	21%	42%	50%
<b>Q18. You say that health and safety in management is not important. Why do you say this? Please select up to 3 reasons.</b>	<b>Base</b>	10	1	-	1	-	1	1	-	-	-	1	2	1
We believe accidents are inevitable in the workplace and cannot be prevented		30%	100%	-	-	-	-	-	-	-	-	-	50%	-
In the event of an accident, it is unlikely we will be required to pay compensation		30%	-	-	-	-	100%	-	-	-	-	-	50%	-
In the event of an accident, it is unlikely to negatively affect staff morale		10%	-	-	-	-	-	-	-	-	-	-	-	100%
In the event of an accident, our reputation will not suffer		20%	100%	-	100%	-	-	-	-	-	-	-	-	-
Staff do not place importance on health and safety		-	-	-	-	-	-	-	-	-	-	-	-	-
Because the current top management does not place much importance to it		-	-	-	-	-	-	-	-	-	-	-	-	-
Because previous top management did not place much importance to it		-	-	-	-	-	-	-	-	-	-	-	-	-
Because the company has hardly / never experienced an accident		40%	-	-	-	-	-	100%	-	-	-	100%	50%	100%
Even if it is punished by law, it will not be a big disadvantage		20%	100%	-	-	-	-	-	-	-	-	-	-	100%
Other		20%	-	-	-	-	-	100%	-	-	-	-	50%	-

Cell Contents (C)

**Kindai University Osaka**  
Health & Safety survey

Fieldwork Dates: 9th - 18th December 2020



	Total	Involvement with H&S					Business size						
		Local government (not classified elsewhere)	Others	Directly involved	Indirectly involved	Not involved	0 people	1-9 people	10-49 people	50-99 people	100-499 people	500-999 people	Over 1,000 people
<b>Q1. Please answer your gender</b>													
Base	1005	36	209	508	357	140	-	293	106	103	191	65	247
Male	62%	67%	55%	62%	64%	54%	-	64%	52%	53%	64%	60%	66%
Female	38%	33%	45%	38%	36%	46%	-	36%	48%	47%	36%	40%	34%
<b>Q2. Age</b>													
Base	1005	36	209	508	357	140	-	293	106	103	191	65	247
20s	3%	3%	2%	3%	3%	5%	-	2%	3%	5%	4%	8%	4%
30s	18%	17%	15%	18%	18%	16%	-	10%	24%	22%	16%	17%	24%
40s	24%	17%	25%	23%	28%	17%	-	19%	25%	24%	30%	25%	24%
50s	33%	50%	29%	36%	32%	26%	-	34%	33%	30%	33%	28%	36%
60s and over	22%	19%	28%	21%	19%	33%	-	36%	15%	18%	17%	23%	13%
<b>Q3. Nation</b>													
Base	1005	36	209	508	357	140	-	293	106	103	191	65	247
England	85%	86%	84%	87%	83%	82%	-	87%	86%	84%	85%	83%	83%
Wales	3%	6%	5%	4%	3%	4%	-	2%	4%	3%	3%	5%	6%
Scotland	10%	8%	10%	7%	12%	12%	-	10%	8%	10%	9%	11%	10%
Northern Ireland	2%	-	1%	2%	2%	2%	-	1%	2%	3%	2%	2%	2%
<b>Q4. Please answer your occupation.</b>													
Base	1005	36	209	508	357	140	-	293	106	103	191	65	247
Managers, executives and senior officials	57%	64%	53%	61%	56%	44%	-	41%	67%	62%	69%	60%	60%
Professional occupations	20%	22%	17%	19%	20%	25%	-	24%	11%	20%	21%	15%	19%
Associate professional and technical occupations	6%	3%	4%	6%	6%	1%	-	6%	3%	3%	4%	8%	8%
Administrative and secretarial occupations	3%	6%	5%	2%	4%	2%	-	3%	8%	3%	2%	-	2%
Skilled trades occupations	3%	3%	3%	3%	3%	6%	-	7%	1%	4%	-	5%	2%
Caring, leisure and other service occupations	3%	-	3%	3%	2%	2%	-	4%	2%	2%	2%	6%	2%
Sales and customer service occupations	2%	-	1%	2%	3%	4%	-	3%	4%	1%	1%	3%	3%
Process, plant and machine operatives	0%	-	-	0%	1%	-	-	-	1%	-	1%	-	0%
Elementary occupations	0%	-	0%	-	1%	1%	-	1%	-	-	-	-	0%
Other	5%	3%	13%	4%	4%	14%	-	12%	4%	5%	2%	3%	2%
Not Applicable - I don't work	0%	-	0%	-	-	1%	-	0%	-	-	-	-	-
<b>Q5. Please tell us about your position within the company you operate or belong to.</b>													
Base	1005	36	209	508	357	140	-	293	106	103	191	65	247
Company/Organization Manager	25%	3%	30%	33%	15%	20%	-	52%	28%	18%	15%	6%	7%
Executive/Board Member	17%	17%	12%	21%	16%	9%	-	15%	23%	23%	20%	28%	10%
Middle Manager (in HRM division)	6%	6%	8%	8%	6%	2%	-	1%	8%	6%	12%	2%	9%
Middle Manager (in other than HRM division)	27%	42%	23%	20%	38%	26%	-	5%	27%	23%	36%	38%	43%
Professionals (other than safety and health related)	11%	17%	8%	7%	15%	16%	-	9%	7%	15%	11%	17%	13%
Professionals (safety and health related)	4%	8%	3%	6%	1%	-	-	1%	-	6%	2%	5%	9%
Subordinate (in HRM division)	0%	-	0%	0%	0%	-	-	-	-	-	1%	2%	-
Subordinate (in other than HRM division)	1%	-	-	0%	1%	1%	-	1%	-	1%	-	-	1%
Others	6%	6%	11%	4%	6%	15%	-	12%	5%	1%	1%	3%	6%
Not applicable - I don't have any management responsibility.	3%	3%	4%	1%	2%	11%	-	5%	2%	1%	3%	-	2%
<b>Q6. Please tell us about the type of business of the company you operate or belong to. If there are multiple applicable industries, please answer the one that you are mainly involved in.</b>													
Base	1005	36	209	508	357	140	-	293	106	103	191	65	247
Agriculture	1%	-	-	1%	0%	3%	-	2%	-	1%	1%	-	-
Forestry	0%	-	-	0%	0%	-	-	-	-	-	-	2%	0%
Fisheries	0%	-	-	-	0%	-	-	-	-	-	-	2%	-
Mining	0%	-	-	-	0%	-	-	0%	-	-	-	-	-
Construction industry	6%	-	-	8%	3%	3%	-	6%	5%	6%	7%	5%	4%
Manufacturing industry	10%	-	-	10%	11%	9%	-	7%	14%	14%	14%	7%	7%
Electricity, gas, heat supply, water supply	1%	-	-	2%	1%	-	-	1%	-	2%	2%	2%	2%
Information and communication industry	6%	-	-	7%	5%	6%	-	12%	7%	4%	2%	6%	3%
Transportation industry	3%	-	-	3%	3%	3%	-	1%	2%	3%	4%	-	5%
Wholesale / Retail	6%	-	-	6%	6%	7%	-	6%	10%	2%	7%	5%	6%
Finance / Insurance	3%	-	-	3%	3%	4%	-	3%	1%	4%	2%	3%	4%
Real estate industry	4%	-	-	5%	4%	4%	-	5%	2%	5%	5%	3%	3%
Restaurant / accommodation business	4%	-	-	3%	4%	7%	-	2%	3%	6%	3%	6%	6%
Medical and welfare	7%	-	-	8%	7%	6%	-	5%	5%	9%	6%	6%	11%
Education / learning support	14%	-	-	15%	15%	11%	-	5%	14%	22%	23%	18%	14%
Service industry (not classified elsewhere)	7%	-	-	9%	6%	5%	-	12%	7%	8%	6%	6%	4%
National institutions (those not classified elsewhere)	2%	-	-	1%	2%	3%	-	0%	1%	-	1%	2%	6%
Local government (not classified elsewhere)	4%	100%	-	3%	5%	2%	-	0%	-	1%	4%	5%	10%
Others	21%	-	100%	18%	23%	26%	-	29%	30%	17%	15%	17%	14%
<b>Q7. Are you involved in work related to the health and of the company to which you operate or belong to?</b>													
Base	1005	36	209	508	357	140	-	293	106	103	191	65	247
Directly involved	51%	42%	44%	100%	-	-	-	58%	55%	48%	50%	46%	42%
Indirectly involved	36%	50%	33%	-	100%	-	-	19%	38%	45%	40%	45%	45%
Not involved	14%	8%	18%	-	-	100%	-	23%	8%	8%	10%	9%	13%
<b>Q8. Please tell us about the number of employees of the company you operate or belong to.</b>													
Base	1005	36	209	508	357	140	-	293	106	103	191	65	247
0 people	-	-	-	-	-	-	-	-	-	-	-	-	-
1-9 people	29%	3%	41%	34%	16%	47%	-	100%	-	-	-	-	-
10-49 people	11%	-	15%	11%	11%	6%	-	-	100%	-	-	-	-
50-99 people	10%	3%	8%	10%	13%	6%	-	-	-	100%	-	-	-
100-499 people	19%	19%	14%	19%	21%	14%	-	-	-	-	100%	-	-
500-999 people	6%	8%	5%	6%	8%	4%	-	-	-	-	-	100%	-
Over 1,000 people	25%	67%	17%	20%	31%	24%	-	-	-	-	-	-	100%
Don't know	-	-	-	-	-	-	-	-	-	-	-	-	-
<b>Q9. How much, if anything do you know about UK Health and Safety Law (the law, regulations, code of conduct, guidelines, etc.)?</b>													
Base	1005	36	209	508	357	140	-	293	106	103	191	65	247
A great deal	14%	19%	11%	22%	8%	-	-	6%	9%	16%	18%	25%	19%
A fair amount	47%	36%	45%	52%	47%	28%	-	39%	57%	47%	49%	43%	51%
Only a little	30%	36%	29%	21%	40%	36%	-	36%	31%	30%	25%	31%	25%
Hardly anything	8%	8%	13%	4%	6%	26%	-	16%	3%	6%	5%	2%	5%
Nothing at all	2%	-	2%	1%	0%	10%	-	3%	-	2%	2%	-	1%
<b>Q10. When thinking about health and safety regulation in the UK, which of the following most closely resembles your view?</b>													
Base	610	20	116	377	194	39	-	132	70	64	129	44	171
Too strict	11%	-	7%	12%	9%	8%	-	15%	11%	16%	10%	11%	7%
Generally appropriate	79%	80%	85%	77%	81%	79%	-	70%	80%	80%	81%	75%	83%
Not strict enough	5%	15%	3%	5%	4%	3%	-	6%	1%	-	4%	7%	7%
It varies across different areas	6%	5%	4%	5%	5%	10%	-	9%	7%	5%	5%	7%	3%
<b>Q11. Still thinking about health and safety regulation in the UK, which of the following most closely resembles your view?</b>													
Base	610	20	116	377	194	39	-	132	70	64	129	44	171
Regulation is easy to understand and implement	23%	25%	28%	25%	21%	13%	-	24%	16%	22%	21%	23%	26%
There are some aspects that are difficult to understand, but it can be implemented with guidance	72%	75%	70%	71%	73%	79%	-	69%	76%	77%	71%	75%	71%
It is too complicated to understand and implement	5%	-	3%	5%	6%	8%	-	7%	9%	2%	8%	2%	2%
<b>Q12. Since the current Health and Safety at Work Act (HSWA) was enacted in 1974, the number of fatal-injuries in the UK has decreased by more than 80%. What, if anything, do you see as the main reason(s) for this? Please select all that apply</b>													
Base	1005	36	209	508	357	140	-	293	106	103	191	65	247
Comprehensive hazard prevention standards (i.e. standards that clearly indicate what should be done and what should not be done)	48%	61%	50%	51%	45%	45%	-	46%	52%	46%	44%	48%	55%
Implementation of a health and safety management system (e.g. the appointment of a health and safety manager)	51%	81%	51%	54%	50%	42%	-	41%	54%	40%	49%	62%	65%
Better cooperation and coordination when multiple employers carry out construction at the same location	20%	25%	17%	21%	19%	16%	-	21%	13%	14%	18%	20%	26%
Stronger voluntary efforts of staff and management towards health and safety within the workplace	31%	36%	28%	33%	32%	19%	-	30%	34%	26%	30%	31%	33%
Allowing businesses sufficient freedoms to enact their own changes	10%	17%	9%	11%	8%	6%	-	11%	8%	3%	10%	11%	10%
Easy to understand the relationship between laws, regulations, code of conduct, and guidance	17%	33%	20%	19%	17%	11%	-	17%	13%	15%	13%	14%	24%

**Kindai University Osaka**  
**Health & Safety survey**

Fieldwork Dates: 9th - 18th December 2020



	Total	Involvement with H&S					Business size						
		Local government (not classified elsewhere)	Others	Directly involved	Indirectly involved	Not involved	0 people	1-9 people	10-49 people	50-99 people	100-499 people	500-999 people	Over 1,000 people
So-called three-step approach (First, take essential safety measures, second, take engineering measures for risks that cannot be dealt with by that, and third, take human measures such as education for the remaining risks to prevent industrial accidents) is employed	30%	44%	28%	32%	29%	23%	-	27%	25%	21%	31%	28%	38%
Employer liability	54%	53%	56%	54%	57%	48%	-	51%	60%	55%	48%	60%	58%
Potential fines for employees who breach regulations	32%	50%	33%	34%	29%	29%	-	29%	35%	33%	28%	31%	36%
Measures to prevent occupational accidents (providing safe products, providing information on risks, etc.) are passed throughout the supply chain	52%	61%	50%	54%	53%	41%	-	49%	47%	48%	49%	55%	60%
There is an evaluation and registration system for machinery and chemical substances treated in workplace	26%	22%	30%	27%	25%	26%	-	27%	24%	18%	21%	31%	33%
Realistic and well-balanced regulations	28%	44%	32%	30%	27%	26%	-	29%	24%	28%	26%	23%	33%
Under this law, the HSE (Health and Safety Executive) has implemented appropriate health and safety guidance based on high expertise	43%	56%	50%	46%	45%	31%	-	38%	43%	41%	42%	45%	53%
Regular inspections and guidance from independent health and safety inspectors	37%	44%	38%	35%	38%	38%	-	34%	36%	32%	32%	31%	46%
Under this law, a safety representative has supported the health and safety management of employers	23%	47%	20%	24%	24%	20%	-	17%	21%	16%	21%	32%	34%
Fines being issued to employees in the past	29%	42%	30%	32%	26%	26%	-	29%	26%	26%	25%	38%	32%
Potential fines for senior management if regulations are violated	38%	42%	43%	39%	39%	32%	-	37%	34%	39%	36%	42%	40%
Other	4%	3%	3%	4%	3%	1%	-	5%	3%	4%	2%	2%	4%
Don't know	8%	3%	13%	5%	7%	22%	-	14%	7%	5%	6%	8%	4%
<b>Q13. When thinking about potential changes to the current Health and Safety at Work Act, which of the following issues, if any, do you think need greater focus?</b>													
Base	1005	36	209	508	357	140	-	293	106	103	191	65	247
A stronger definition of 'welfare' in the legal context	23%	36%	22%	24%	25%	14%	-	17%	15%	17%	24%	31%	32%
A stronger definition of 'reasonable practicable' in the legal context	27%	47%	27%	31%	26%	13%	-	19%	24%	33%	28%	35%	32%
Legal nature of the Code of Conduct (ACOP)	11%	19%	8%	12%	12%	8%	-	5%	8%	8%	10%	26%	18%
A stronger definition of legal obligations imposed on stakeholders (e.g. managers, designers, manufacturers)	23%	31%	20%	25%	24%	11%	-	16%	20%	19%	26%	28%	29%
Stronger definition of risk for those working in spaces where harmful substances are handled	14%	11%	13%	15%	13%	12%	-	18%	8%	10%	13%	12%	14%
Stronger assessment of risks posed to workers dealing with chemical substances	19%	25%	16%	20%	19%	17%	-	22%	11%	15%	17%	20%	24%
Stronger management of risks posed to workers dealing with chemical substances (e.g. controlling exposure)	19%	19%	15%	18%	20%	16%	-	19%	8%	17%	20%	20%	23%
Measures to raise management awareness of health and safety regardless of business scale	28%	36%	31%	28%	30%	24%	-	23%	27%	27%	30%	37%	32%
Current status/ importance placed on safety specialists in companies and society and measures to improve them	11%	19%	11%	11%	12%	6%	-	8%	6%	13%	12%	14%	14%
Current status/ importance placed on hygiene specialists in companies and society and measures to improve them	9%	17%	6%	10%	8%	6%	-	8%	6%	4%	9%	6%	14%
The appointment of an industrial physician be required by law	5%	11%	5%	5%	5%	5%	-	2%	5%	2%	6%	9%	9%
Introduction of mandatory health checks	17%	25%	16%	17%	17%	13%	-	13%	13%	18%	17%	22%	20%
How to control the safety and health risks of older employees	17%	33%	15%	17%	16%	20%	-	15%	14%	18%	17%	18%	22%
Measures to promote cooperation between community and occupational health management	11%	25%	11%	11%	12%	9%	-	11%	5%	11%	13%	9%	14%
How safety and health laws and regulations should be for self-employed people such as cloud workers and freelancers	24%	17%	29%	27%	20%	25%	-	28%	22%	25%	21%	17%	25%
Stronger definition on health and safety laws for mobile workers	21%	42%	22%	22%	20%	19%	-	17%	17%	16%	21%	20%	29%
Greater focus on employee mental health	40%	44%	39%	42%	39%	35%	-	32%	31%	44%	43%	43%	47%
Greater importance of Health and Safety Law in civil cases	12%	25%	15%	13%	13%	6%	-	13%	10%	8%	10%	11%	15%
Other	4%	3%	2%	4%	4%	1%	-	4%	4%	6%	2%	9%	2%
Don't know	21%	8%	28%	16%	20%	41%	-	34%	24%	14%	14%	12%	13%
<b>Q14. How much importance do you place on health and safety in management?</b>													
Base	424	7	88	274	109	41	-	196	54	43	68	22	41
Very important	67%	86%	75%	70%	66%	54%	-	62%	65%	67%	74%	77%	83%
Moderately important	25%	14%	20%	24%	27%	22%	-	26%	31%	23%	24%	23%	12%
Neutral	6%	-	2%	4%	6%	15%	-	9%	4%	7%	1%	-	2%
Not very important	1%	-	1%	1%	-	5%	-	3%	-	-	1%	-	-
Not at all important	1%	-	1%	-	2%	5%	-	1%	-	2%	-	-	2%
<b>Q15. You say that health and safety in management is important. Why do you say this? Please select up to three reasons.</b>													
Base	390	7	84	258	101	31	-	172	52	39	66	22	39
I do not want the emotional toll of being responsible for an accident	52%	57%	44%	51%	55%	42%	-	53%	67%	41%	50%	36%	46%
An accident could lead to paying a large compensation	24%	43%	17%	24%	26%	19%	-	17%	35%	26%	27%	45%	23%
An accident could negatively affect company morale	36%	29%	37%	36%	35%	42%	-	33%	38%	38%	41%	23%	46%
An accident could negatively affect my company's reputation	47%	57%	45%	47%	50%	48%	-	44%	42%	41%	59%	59%	51%
It is the company policy	27%	43%	26%	27%	28%	19%	-	27%	21%	21%	21%	32%	44%
The company has experienced a major industrial accident before	3%	-	5%	3%	3%	3%	-	1%	3%	3%	3%	14%	10%
I could be punished for violating the law	27%	29%	20%	29%	25%	23%	-	31%	25%	21%	29%	23%	21%
An accident could lead to more absenteeism from employees	17%	14%	13%	18%	18%	10%	-	12%	19%	13%	21%	32%	21%
Other	14%	14%	23%	14%	16%	13%	-	16%	10%	21%	14%	9%	10%
<b>Q16. In your approach to health and safety, which of the following measures, if any, are you currently taking? Please select up to three.</b>													
Base	127	6	17	69	48	10	-	-	-	-	66	22	39
We have dedicated senior managers in charge of health and safety	67%	100%	65%	71%	69%	30%	-	-	-	-	65%	68%	69%
We offer generous remuneration for health and safety specialists	13%	33%	6%	9%	19%	10%	-	-	-	-	9%	14%	18%
A department in charge of safety and health has been set up, and one or more staff members are assigned for every 100 employees	22%	-	12%	25%	17%	30%	-	-	-	-	20%	41%	15%
We respect the authority of the health and safety specialists within the business	66%	100%	65%	65%	69%	60%	-	-	-	-	68%	77%	56%
The staff assigned to the department in charge of safety and health is reassigned to a central department (personnel department or business management department) of the company or appointed as an officer	33%	33%	41%	36%	31%	20%	-	-	-	-	21%	45%	46%
Other	5%	17%	12%	6%	4%	-	-	-	-	-	3%	-	10%
None of these	5%	-	6%	3%	4%	20%	-	-	-	-	6%	-	5%
<b>Q17. In your approach to health and safety, which of the following measures, if any, are you currently taking? Please select up to three.</b>													
Base	263	1	67	189	53	21	-	172	52	39	-	-	-
We have a health and safety committee	16%	-	10%	16%	21%	5%	-	10%	19%	41%	-	-	-
An independent health and safety expert is invited to participate in the health and safety committee	11%	-	9%	10%	19%	-	-	6%	10%	33%	-	-	-
A health and safety assistant has been appointed within the company	28%	100%	19%	30%	32%	-	-	20%	40%	46%	-	-	-
We have commissioned an external health and safety consultant to conduct a workplace assessment and issue guidance	22%	-	19%	21%	28%	19%	-	13%	37%	41%	-	-	-
Other	10%	-	15%	12%	9%	-	-	14%	4%	3%	-	-	-
None of these	37%	-	42%	37%	21%	81%	-	47%	21%	13%	-	-	-
<b>Q18. You say that health and safety in management is not important. Why do you say this? Please select up to 3 reasons.</b>													
Base	10	-	2	4	2	4	-	7	-	1	1	-	1
We believe accidents are inevitable in the workplace and cannot be prevented	30%	-	50%	25%	50%	25%	-	29%	-	100%	-	-	-
In the event of an accident, it is unlikely we will be required to pay compensation	30%	-	50%	50%	-	25%	-	43%	-	-	-	-	-
In the event of an accident, it is unlikely to negatively affect staff morale	10%	-	-	-	50%	-	-	-	-	-	-	-	100%
In the event of an accident, our reputation will not suffer	20%	-	-	-	50%	25%	-	14%	-	100%	-	-	-
Staff do not place importance on health and safety	-	-	-	-	-	-	-	-	-	-	-	-	-
Because the current top management does not place much importance to it	-	-	-	-	-	-	-	-	-	-	-	-	-
Because previous top management did not place much importance to it	-	-	-	-	-	-	-	-	-	-	-	-	-
Because the company has hardly / never experienced an accident	40%	-	-	75%	50%	-	-	29%	-	-	100%	-	100%
Even if it is punished by law, it will not be a big disadvantage	20%	-	-	-	100%	-	-	-	-	100%	-	-	100%
Other	20%	-	-	25%	-	25%	-	29%	-	-	-	-	-

Cell Contents (C)



**Kindai University Osaka**  
**Health & Safety survey**

Fieldwork Dates: 9th - 18th December 2020



	Total	Knowledge of H&S											
		Don't know	A great deal	A fair amount	Only a little	Hardly anything	Nothing at all	Top 2 familiar	Bottom 2 familiar	Familiar + Managers, executives and senior officials	Familiar + Professional occupations	Familiar + Associate professional and technical occupations	Familiar + Administrative and secretarial occupations
<b>Q1. Please answer your gender</b>													
Base	1005	-	140	470	299	78	18	610	96	380	113	35	15
Male	62%	-	76%	64%	54%	58%	33%	67%	53%	68%	71%	69%	13%
Female	38%	-	24%	36%	46%	42%	67%	33%	47%	32%	29%	31%	87%
<b>Q2. Age</b>													
Base	1005	-	140	470	299	78	18	610	96	380	113	35	15
20s	3%	-	2%	4%	3%	4%	1%	3%	5%	3%	3%	-	-
30s	18%	-	15%	16%	19%	26%	1%	16%	24%	15%	15%	14%	27%
40s	24%	-	21%	23%	27%	22%	1%	23%	21%	22%	27%	11%	33%
50s	33%	-	43%	34%	30%	28%	2%	36%	27%	39%	31%	46%	20%
60s and over	22%	-	19%	23%	21%	21%	3%	22%	23%	20%	24%	29%	20%
<b>Q3. Nation</b>													
Base	1005	-	140	470	299	78	18	610	96	380	113	35	15
England	85%	-	84%	87%	84%	81%	83%	86%	81%	83%	83%	91%	87%
Wales	3%	-	4%	3%	3%	5%	6%	3%	5%	3%	4%	3%	7%
Scotland	10%	-	9%	9%	11%	12%	1%	9%	11%	8%	12%	6%	-
Northern Ireland	2%	-	2%	2%	2%	3%	-	2%	2%	2%	-	-	7%
<b>Q4. Please answer your occupation.</b>													
Base	1005	-	140	470	299	78	18	610	96	380	113	35	15
Managers, executives and senior officials	57%	-	69%	60%	50%	45%	44%	62%	45%	100%	-	-	-
Professional occupations	20%	-	21%	18%	24%	15%	28%	19%	18%	-	100%	-	-
Associate professional and technical occupations	6%	-	5%	6%	6%	3%	-	6%	2%	-	-	100%	-
Administrative and secretarial occupations	3%	-	3%	4%	1%	6%	2%	2%	-	-	-	-	100%
Skilled trades occupations	3%	-	1%	3%	3%	8%	-	3%	6%	-	-	-	-
Caring, leisure and other service occupations	3%	-	1%	3%	3%	4%	-	6%	2%	4%	-	-	-
Sales and customer service occupations	2%	-	1%	2%	2%	6%	-	2%	5%	-	-	-	-
Process, plant and machine operatives	0%	-	-	0%	0%	-	-	0%	-	-	-	-	-
Elementary occupations	0%	-	-	0%	-	1%	-	0%	1%	-	-	-	-
Other	5%	-	1%	3%	7%	17%	-	3%	17%	-	-	-	-
Not Applicable - I don't work	0%	-	-	-	0%	-	-	-	-	-	-	-	-
<b>Q5. Please tell us about your position within the company you operate or belong to.</b>													
Base	1005	-	140	470	299	78	18	610	96	380	113	35	15
Company/Organization Manager	25%	-	19%	26%	26%	24%	28%	24%	25%	28%	17%	23%	13%
Executive/Board Member	17%	-	24%	17%	17%	13%	1%	18%	13%	26%	8%	11%	-
Middle Manager (in HRM division)	6%	-	6%	8%	4%	4%	1%	8%	5%	7%	9%	9%	20%
Middle Manager (in other than HRM division)	27%	-	21%	29%	29%	22%	1%	27%	21%	29%	16%	20%	53%
Professionals (other than safety and health related)	11%	-	8%	13%	12%	8%	1%	11%	8%	4%	33%	20%	-
Professionals (safety and health related)	4%	-	19%	2%	0%	1%	-	6%	1%	4%	12%	14%	-
Subordinate (in HRM division)	0%	-	1%	0%	-	-	-	0%	-	0%	-	-	7%
Subordinate (in other than HRM division)	1%	-	1%	1%	1%	-	-	1%	-	0%	1%	-	-
Others	6%	-	2%	3%	8%	19%	17%	3%	19%	2%	2%	3%	-
Not applicable - I don't have any management responsibility.	3%	-	1%	2%	2%	9%	6%	2%	8%	0%	4%	-	7%
<b>Q6. Please tell us about the type of business of the company you operate or belong to. If there are multiple applicable industries, please answer the one that you are mainly involved in.</b>													
Base	1005	-	140	470	299	78	18	610	96	380	113	35	15
Agriculture	1%	-	1%	1%	1%	-	-	1%	-	0%	1%	3%	-
Forestry	0%	-	-	0%	-	-	-	0%	-	-	-	3%	-
Fisheries	0%	-	-	0%	-	-	-	-	-	-	-	-	-
Mining	0%	-	-	0%	-	-	-	0%	-	-	-	-	-
Construction industry	6%	-	11%	6%	4%	-	-	7%	-	5%	11%	17%	7%
Manufacturing industry	10%	-	11%	12%	8%	8%	6%	12%	7%	14%	5%	9%	7%
Electricity, gas, heat supply, water supply	1%	-	4%	1%	0%	-	6%	2%	1%	4%	1%	2%	9%
Information and communication industry	6%	-	5%	5%	8%	6%	6%	5%	5%	6%	8%	6%	-
Transportation industry	3%	-	3%	3%	2%	5%	-	3%	4%	3%	2%	9%	-
Wholesale / Retail	6%	-	6%	6%	6%	8%	1%	6%	8%	7%	1%	9%	-
Finance / Insurance	3%	-	2%	3%	4%	1%	6%	3%	2%	3%	4%	-	-
Real estate industry	4%	-	4%	4%	4%	5%	-	4%	4%	4%	4%	6%	-
Restaurant / accommodation business	4%	-	2%	4%	3%	5%	1%	4%	6%	4%	1%	-	7%
Medical and welfare	7%	-	4%	7%	9%	9%	-	6%	7%	7%	8%	-	-
Education / learning support	14%	-	13%	15%	15%	8%	2%	15%	10%	14%	22%	14%	-
Service industry (not classified elsewhere)	7%	-	5%	10%	6%	5%	6%	8%	5%	8%	6%	6%	13%
National institutions (those not classified elsewhere)	2%	-	2%	1%	3%	1%	6%	1%	2%	1%	5%	-	-
Local government (not classified elsewhere)	4%	-	5%	3%	4%	4%	-	3%	4%	2%	-	-	13%
Others	21%	-	16%	20%	20%	35%	28%	19%	33%	19%	16%	11%	53%
<b>Q7. Are you involved in work related to the health and of the company to which you operate or belong to?</b>													
Base	1005	-	140	470	299	78	18	610	96	380	113	35	15
Directly involved	51%	-	80%	56%	36%	26%	17%	62%	24%	66%	59%	71%	40%
Indirectly involved	36%	-	20%	35%	47%	27%	6%	32%	23%	30%	28%	29%	60%
Not involved	14%	-	-	8%	17%	47%	78%	6%	53%	4%	12%	-	-
<b>Q8. Please tell us about the number of employees of the company you operate or belong to.</b>													
Base	1005	-	140	470	299	78	18	610	96	380	113	35	15
0 people	-	-	-	-	-	-	-	-	-	-	-	-	-
1-9 people	29%	-	12%	24%	35%	59%	50%	22%	57%	18%	29%	29%	27%
10-49 people	11%	-	7%	13%	15%	4%	1%	11%	3%	13%	4%	9%	27%
50-99 people	10%	-	11%	10%	6%	5%	1%	10%	8%	11%	1%	3%	13%
100-499 people	19%	-	25%	20%	16%	13%	22%	21%	15%	23%	24%	14%	13%
500-999 people	6%	-	11%	6%	7%	1%	-	7%	1%	7%	5%	9%	-
Over 1,000 people	25%	-	33%	27%	20%	15%	17%	28%	16%	28%	27%	37%	20%
Don't know	-	-	-	-	-	-	-	-	-	-	-	-	-
<b>Q9. How much, if anything do you know about UK Health and Safety Law (the law, regulations, code of conduct, guidelines, etc.)?</b>													
Base	1005	-	140	470	299	78	18	610	96	380	113	35	15
A great deal	14%	-	100%	-	-	-	-	23%	-	25%	26%	20%	-
A fair amount	47%	-	-	100%	-	-	-	77%	-	75%	74%	80%	100%
Only a little	30%	-	-	-	100%	-	-	-	-	-	-	-	-
Hardly anything	8%	-	-	-	-	100%	-	-	-	81%	-	-	-
Nothing at all	2%	-	-	-	-	-	100%	-	-	19%	-	-	-
<b>Q10. When thinking about health and safety regulation in the UK, which of the following most closely resembles your view?</b>													
Base	610	-	140	470	-	-	-	610	-	380	113	35	15
Too strict	11%	-	13%	11%	-	-	-	11%	-	13%	7%	9%	7%
Generally appropriate	79%	-	74%	80%	-	-	-	79%	-	78%	81%	80%	73%
Not strict enough	5%	-	7%	4%	-	-	-	5%	-	4%	7%	-	13%
It varies across different areas	6%	-	6%	5%	-	-	-	6%	-	5%	4%	11%	7%
<b>Q11. Still thinking about health and safety regulation in the UK, which of the following most closely resembles your view?</b>													
Base	610	-	140	470	-	-	-	610	-	380	113	35	15
Regulation is easy to understand and implement	23%	-	36%	19%	-	-	-	23%	-	23%	20%	14%	27%
There are some aspects that are difficult to understand, but it can be implemented with guidance	72%	-	60%	76%	-	-	-	72%	-	71%	75%	80%	73%
It is too complicated to understand and implement	5%	-	4%	5%	-	-	-	5%	-	6%	4%	6%	-
<b>Q12. Since the current Health and Safety at Work Act (HSWA) was enacted in 1974, the number of fatal-injuries in the UK has decreased by more than 80%. What, if anything, do you see as the main reason(s) for this? Please select all that apply</b>													
Base	1005	-	140	470	299	78	18	610	96	380	113	35	15
Comprehensive hazard prevention standards (i.e. standards that clearly indicate what should be done and what should not be done)	48%	-	51%	51%	48%	37%	22%	51%	34%	52%	50%	43%	60%
Implementation of a health and safety management system (e.g. the appointment of a health and safety manager)	51%	-	64%	54%	46%	32%	33%	56%	32%	56%	58%	63%	47%
Better cooperation and coordination when multiple employers carry out construction at the same location	20%	-	29%	21%	17%	14%	6%	23%	13%	21%	24%	37%	13%
Stronger voluntary efforts of staff and management towards health and safety within the workplace	31%	-	37%	35%	26%	15%	11%	35%	15%	35%	36%	29%	47%
Allowing businesses sufficient freedoms to enact their own changes	10%	-	18%	9%	9%	-	6%	11%	1%	11%	11%	6%	13%
Easy to understand the relationship between laws, regulations, code of conduct, and guidance	17%	-	22%	19%	14%	13%	11%	20%	13%	19%	20%	17%	13%





	Total	Knowledge of H&S											
		Don't know	A great deal	A fair amount	Only a little	Hardly anything	Nothing at all	Top 2 familiar	Bottom 2 familiar	Familiar + Managers, executives and senior officials	Familiar + Professional occupations	Familiar + Associate professional and technical occupations	Familiar + Administrative and secretarial occupations
So-called three-step approach (First, take essential safety measures, second, take engineering measures for risks that cannot be dealt with by that, and third, take human measures such as education for the remaining risks to prevent industrial accidents) is employed	30%	-	46%	32%	23%	19%	6%	35%	17%	36%	37%	34%	7%
Employer liability	54%	-	59%	59%	51%	37%	28%	59%	35%	59%	58%	57%	47%
Potential fines for employees who breach regulations	32%	-	35%	37%	23%	27%	17%	37%	25%	37%	39%	40%	40%
Measures to prevent occupational accidents (providing safe products, providing information on risks, etc.) are passed throughout the supply chain	52%	-	54%	57%	47%	35%	33%	56%	34%	56%	58%	57%	53%
There is an evaluation and registration system for machinery and chemical substances treated in workplace	26%	-	34%	28%	22%	22%	17%	29%	21%	28%	29%	31%	27%
Realistic and well-balanced regulations	28%	-	36%	27%	29%	19%	11%	29%	29%	29%	33%	20%	40%
Under this law, the HSE (Health and Safety Executive) has implemented appropriate health and safety guidance based on high expertise	43%	-	54%	44%	42%	33%	11%	46%	29%	46%	53%	34%	47%
Regular inspections and guidance from independent health and safety inspectors	37%	-	37%	38%	35%	35%	11%	38%	30%	37%	42%	37%	33%
Under this law, a safety representative has supported the health and safety management of employers	23%	-	31%	25%	22%	6%	11%	26%	7%	28%	25%	29%	13%
Fines being issued to employers in the past	29%	-	34%	30%	26%	24%	11%	31%	22%	32%	28%	34%	33%
Potential fines for senior management if regulations are violated	38%	-	46%	41%	33%	29%	11%	42%	26%	42%	42%	60%	53%
Other	4%	-	6%	4%	2%	5%	-	4%	4%	3%	6%	6%	-
Don't know	8%	-	1%	3%	12%	26%	39%	2%	28%	2%	2%	3%	-
<b>Q13. When thinking about potential changes to the current Health and Safety at Work Act, which of the following issues, if any, do you think need greater focus?</b>													
Base	1005	-	140	470	299	78	18	610	96	380	113	35	15
A stronger definition of 'welfare' in the legal context	23%	-	31%	27%	18%	9%	-	28%	7%	26%	33%	29%	27%
A stronger definition of 'reasonable practicable' in the legal context	27%	-	37%	31%	21%	6%	17%	33%	8%	33%	34%	40%	33%
Legal nature of the Code of Conduct (ACOP)	11%	-	24%	11%	8%	3%	-	14%	2%	13%	15%	26%	13%
A stronger definition of legal obligations imposed on stakeholders (e.g. managers, designers, manufacturers)	23%	-	31%	26%	20%	5%	-	27%	4%	29%	25%	29%	7%
Stronger definition of risk for those working in spaces where harmful substances are handled	14%	-	16%	14%	14%	10%	-	14%	8%	15%	14%	17%	-
Stronger assessment of risks posed to workers dealing with chemical substances	19%	-	21%	21%	18%	10%	17%	21%	11%	19%	26%	20%	7%
Stronger management of risks posed to workers dealing with chemical substances (e.g. controlling exposure)	19%	-	25%	18%	18%	14%	11%	20%	14%	19%	19%	23%	7%
Measures to raise management awareness of health and safety regardless of business scale	28%	-	38%	30%	26%	17%	-	31%	14%	34%	32%	23%	7%
Current status/ importance placed on safety specialists in companies and society and measures to improve them	11%	-	24%	9%	9%	1%	-	13%	1%	13%	14%	17%	7%
Current status/ importance placed on hygiene specialists in companies and society and measures to improve them	9%	-	13%	8%	8%	3%	22%	9%	6%	7%	12%	17%	7%
The appointment of an industrial physician be required by law	5%	-	9%	6%	4%	1%	-	6%	1%	6%	9%	3%	-
Introduction of mandatory health checks	17%	-	16%	19%	16%	6%	-	18%	5%	16%	25%	14%	7%
How to control the safety and health risks of older employees	17%	-	19%	16%	19%	9%	17%	17%	10%	16%	19%	23%	13%
Measures to promote cooperation between community and occupational health management	11%	-	18%	12%	8%	5%	6%	14%	5%	12%	18%	11%	40%
How safety and health laws and regulations should be for self-employed people such as cloud workers and freelancers	24%	-	35%	23%	21%	23%	17%	26%	22%	25%	27%	37%	40%
Stronger definition on health and safety laws for mobile workers	21%	-	26%	23%	19%	12%	6%	23%	10%	23%	27%	23%	13%
Greater focus on employee mental health	40%	-	40%	45%	36%	29%	17%	44%	27%	42%	57%	40%	33%
Greater importance of Health and Safety Law in civil cases	12%	-	17%	12%	10%	9%	6%	13%	8%	12%	16%	17%	7%
Other	4%	-	11%	3%	3%	3%	-	5%	2%	3%	7%	9%	-
Don't know	21%	-	6%	14%	30%	47%	44%	12%	47%	12%	8%	6%	13%
<b>Q14. How much importance do you place on health and safety in management?</b>													
Base	424	-	60	199	129	29	7	259	36	204	28	12	2
Very important	67%	-	83%	72%	58%	48%	43%	75%	47%	77%	75%	58%	-
Moderately important	25%	-	12%	24%	32%	21%	29%	21%	22%	19%	25%	33%	100%
Neutral	6%	-	3%	3%	8%	17%	14%	3%	17%	3%	-	8%	-
Not very important	1%	-	2%	1%	2%	7%	-	1%	6%	1%	-	-	-
Not at all important	1%	-	-	-	1%	7%	14%	-	8%	-	-	-	-
<b>Q15. You say that health and safety in management is important. Why do you say this? Please select up to three reasons.</b>													
Base	390	-	57	192	116	20	5	249	25	196	28	11	2
I do not want the emotional toll of being responsible for an accident	52%	-	37%	56%	53%	55%	20%	51%	48%	51%	61%	55%	100%
An accident could lead to paying a large compensation	24%	-	28%	22%	28%	15%	20%	23%	16%	24%	14%	36%	-
An accident could negatively affect company morale	36%	-	42%	39%	28%	35%	40%	40%	36%	41%	43%	18%	50%
An accident could negatively affect my company's reputation	47%	-	51%	53%	36%	45%	60%	53%	48%	54%	54%	45%	50%
It is the company policy	27%	-	35%	25%	29%	5%	20%	27%	8%	28%	21%	45%	-
The company has experienced a major industrial accident before	3%	-	12%	2%	1%	5%	-	4%	4%	5%	-	-	-
I could be punished for violating the law	27%	-	14%	29%	35%	15%	-	25%	12%	24%	14%	36%	-
An accident could lead to more absenteeism from employees	17%	-	23%	17%	17%	10%	20%	18%	12%	18%	18%	18%	-
Other	14%	-	19%	13%	14%	10%	20%	14%	12%	14%	14%	9%	-
<b>Q16. In your approach to health and safety, which of the following measures, if any, are you currently taking? Please select up to three.</b>													
Base	127	-	34	62	26	3	2	96	5	86	8	2	-
We have dedicated senior managers in charge of health and safety	67%	-	68%	73%	54%	67%	50%	71%	60%	72%	50%	100%	-
We offer generous remuneration for health and safety specialists	13%	-	29%	6%	8%	-	-	15%	-	15%	13%	-	-
A department in charge of safety and health has been set up, and one or more staff members are assigned for every 100 employees	22%	-	38%	16%	12%	67%	-	24%	40%	23%	25%	50%	-
We respect the authority of the health and safety specialists within the business	66%	-	68%	61%	77%	67%	50%	64%	60%	65%	63%	-	-
The staff assigned to the department in charge of safety and health is reassigned to a central department (personnel department or business management department) of the company or appointed as an officer	33%	-	32%	37%	31%	-	-	35%	-	35%	38%	50%	-
Other	5%	-	9%	3%	4%	-	-	5%	-	6%	-	-	-
None of these	5%	-	3%	5%	8%	-	-	4%	-	3%	13%	-	-
<b>Q17. In your approach to health and safety, which of the following measures, if any, are you currently taking? Please select up to three.</b>													
Base	263	-	23	130	90	17	3	153	20	110	20	9	2
We have a health and safety committee	16%	-	30%	19%	10%	12%	-	21%	10%	24%	15%	11%	-
An independent health and safety expert is invited to participate in the health and safety committee.	11%	-	26%	9%	10%	12%	-	12%	10%	14%	5%	-	-
A health and safety assistant has been appointed within the company	28%	-	30%	32%	23%	18%	33%	31%	20%	36%	30%	11%	-
We have commissioned an external health and safety consultant to conduct a workplace assessment and issue guidance	22%	-	30%	25%	18%	18%	-	25%	15%	30%	20%	-	-
Other	10%	-	13%	11%	10%	6%	-	11%	5%	6%	20%	22%	-
None of these	37%	-	17%	31%	44%	65%	67%	29%	65%	23%	35%	56%	100%
<b>Q18. You say that health and safety in management is not important. Why do you say this? Please select up to 3 reasons.</b>													
Base	10	-	1	1	3	4	1	2	5	2	-	-	-
We believe accidents are inevitable in the workplace and cannot be prevented	30%	-	100%	-	-	25%	100%	50%	40%	50%	-	-	-
In the event of an accident, it is unlikely we will be required to pay compensation	30%	-	100%	-	-	50%	-	50%	40%	50%	-	-	-
In the event of an accident, it is unlikely to negatively affect staff morale	10%	-	-	-	33%	-	-	-	-	-	-	-	-
In the event of an accident, our reputation will not suffer	20%	-	-	-	33%	25%	-	-	20%	-	-	-	-
Staff do not place importance on health and safety	-	-	-	-	-	-	-	-	-	-	-	-	-
Because the current top management does not place much importance to it	-	-	-	-	-	-	-	-	-	-	-	-	-
Because previous top management did not place much importance to it	-	-	-	-	-	-	-	-	-	-	-	-	-
Because the company has hardly / never experienced an accident	40%	-	100%	-	67%	25%	-	50%	20%	50%	-	-	-
Even if it is punished by law, it will not be a big disadvantage	20%	-	-	-	33%	25%	-	-	20%	-	-	-	-
Other	20%	-	-	100%	33%	-	-	50%	-	50%	-	-	-

**Kindai University Osaka**  
**Health & Safety survey**

Fieldwork Dates: 9th - 18th December 2020



	Total	Familiarity x Occupation							Familiarity x Role					
		Familiar + Skilled trades occupations	Familiar + Caring, leisure and other service occupations	Familiar + Sales and customer service occupations	Familiar + Process, plant and machine operatives	Familiar + Elementary occupations	Familiar + Other	Familiar + Company/Organisation Manager	Familiar + Executive/Board Member	Familiar + Middle Manager (in HRM division)	Familiar + Middle Manager (in other than HRM division)	Familiar + Professionals (other than health related)	Familiar + Professionals (safety and health related)	
<b>Q1. Please answer your gender</b>														
Base	1005	18	14	13	2	2	18	147	112	47	165	69	34	
Male	62%	83%	36%	62%	100%	100%	61%	63%	78%	53%	60%	75%	82%	
Female	38%	17%	64%	38%	-	-	39%	37%	22%	47%	40%	25%	18%	
<b>Q2. Age</b>														
Base	1005	18	14	13	2	2	18	147	112	47	165	69	34	
20s	3%	6%	14%	8%	-	-	6%	1%	-	6%	7%	4%	3%	
30s	18%	6%	36%	23%	50%	-	17%	10%	10%	21%	21%	20%	18%	
40s	24%	17%	21%	23%	-	-	29%	22%	20%	19%	27%	28%	12%	
50s	33%	39%	14%	15%	50%	-	17%	46%	37%	40%	33%	26%	41%	
60s and over	22%	33%	14%	31%	-	50%	33%	20%	34%	13%	12%	22%	26%	
<b>Q3. Nation</b>														
Base	1005	18	14	13	2	2	18	147	112	47	165	69	34	
England	85%	100%	64%	85%	100%	-	89%	90%	88%	81%	85%	84%	88%	
Wales	3%	-	7%	-	-	50%	6%	1%	2%	2%	5%	6%	3%	
Scotland	10%	-	29%	8%	-	50%	6%	7%	9%	6%	10%	10%	6%	
Northern Ireland	2%	-	-	8%	-	-	-	1%	2%	11%	-	-	3%	
<b>Q4. Please answer your occupation.</b>														
Base	1005	18	14	13	2	2	18	147	112	47	165	69	34	
Managers, executives and senior officials	57%	-	-	-	-	-	-	72%	88%	57%	67%	22%	41%	
Professional occupations	20%	-	-	-	-	-	-	13%	8%	21%	11%	54%	38%	
Associate professional and technical occupations	6%	-	-	-	-	-	-	5%	4%	6%	4%	10%	15%	
Administrative and secretarial occupations	3%	-	-	-	-	-	-	1%	-	6%	5%	-	-	
Skilled trades occupations	3%	100%	-	-	-	-	-	3%	-	2%	2%	6%	-	
Caring, leisure and other service occupations	3%	-	100%	-	-	-	-	1%	-	-	5%	1%	-	
Sales and customer service occupations	2%	-	-	100%	-	-	-	1%	-	2%	3%	1%	-	
Process, plant and machine operatives	0%	-	-	-	100%	-	-	1%	-	-	-	1%	-	
Elementary occupations	0%	-	-	-	-	100%	-	-	-	2%	-	1%	-	
Other	5%	-	-	-	-	-	100%	1%	1%	2%	2%	3%	6%	
Not Applicable - I don't work	0%	-	-	-	-	-	-	-	-	-	-	-	-	
<b>Q5. Please tell us about your position within the company you operate or belong to.</b>														
Base	1005	18	14	13	2	2	18	147	112	47	165	69	34	
Company/Organization Manager	25%	28%	14%	15%	50%	-	11%	100%	-	-	-	-	-	
Executive/Board Member	17%	-	-	-	-	-	6%	-	100%	-	-	-	-	
Middle Manager (in HRM division)	6%	6%	-	8%	-	50%	6%	-	-	100%	-	-	-	
Middle Manager (in other than HRM division)	27%	22%	64%	38%	-	22%	-	-	-	-	100%	-	-	
Professionals (other than safety and health related)	11%	22%	7%	8%	50%	50%	11%	-	-	-	-	100%	-	
Professionals (safety and health related)	4%	-	-	-	-	-	11%	-	-	-	-	-	100%	
Subordinate (in HRM division)	0%	-	-	-	-	-	-	-	-	-	-	-	-	
Subordinate (in other than HRM division)	1%	6%	7%	-	-	-	-	-	-	-	-	-	-	
Others	6%	11%	-	23%	-	-	17%	-	-	-	-	-	-	
Not applicable - I don't have any management responsibility.	3%	6%	7%	8%	-	-	17%	-	-	-	-	-	-	
<b>Q6. Please tell us about the type of business of the company you operate or belong to. If there are multiple applicable industries, please answer the one that you are mainly involved in.</b>														
Base	1005	18	14	13	2	2	18	147	112	47	165	69	34	
Agriculture	1%	11%	-	-	-	-	-	1%	1%	-	1%	3%	-	
Forestry	0%	6%	-	-	-	-	-	-	-	-	-	1%	-	
Fisheries	0%	-	-	-	-	-	-	-	-	-	-	-	-	
Mining	0%	6%	-	-	-	-	-	-	-	-	-	-	-	
Construction industry	6%	17%	-	8%	50%	50%	-	7%	6%	11%	2%	19%	9%	
Manufacturing industry	10%	29%	-	15%	50%	-	6%	10%	21%	9%	12%	7%	12%	
Electricity, gas, heat supply, water supply	1%	6%	-	-	-	-	-	1%	2%	2%	2%	4%	9%	
Information and communication industry	6%	-	-	-	-	-	-	7%	8%	2%	3%	6%	6%	
Transportation industry	3%	-	-	-	-	-	-	2%	4%	4%	2%	3%	6%	
Wholesale / Retail	6%	-	-	38%	-	-	11%	9%	4%	13%	4%	4%	3%	
Finance / Insurance	3%	-	7%	-	-	-	-	-	5%	2%	2%	6%	3%	
Real estate industry	4%	-	7%	-	-	-	-	6%	3%	4%	2%	7%	3%	
Restaurant / accommodation business	4%	11%	29%	8%	-	-	6%	2%	2%	2%	8%	3%	-	
Medical and welfare	7%	-	21%	-	-	-	11%	3%	7%	4%	7%	6%	15%	
Education / learning support	14%	-	7%	-	-	50%	22%	10%	15%	15%	18%	19%	15%	
Service industry (not classified elsewhere)	7%	-	-	15%	-	-	-	17%	9%	6%	6%	6%	3%	
National institutions (those not classified elsewhere)	2%	-	-	-	-	-	6%	1%	-	2%	2%	3%	9%	
Local government (not classified elsewhere)	4%	-	-	-	-	-	-	1%	3%	2%	5%	3%	9%	
Others	21%	17%	29%	15%	-	-	33%	27%	13%	23%	19%	10%	15%	
<b>Q7. Are you involved in work related to the health and of the company to which you operate or belong to?</b>														
Base	1005	18	14	13	2	2	18	147	112	47	165	69	34	
Directly involved	51%	44%	71%	23%	-	-	39%	75%	74%	74%	49%	43%	91%	
Indirectly involved	36%	39%	29%	54%	100%	100%	44%	22%	23%	23%	44%	45%	9%	
Not involved	14%	17%	-	23%	-	-	17%	3%	3%	2%	7%	12%	-	
<b>Q8. Please tell us about the number of employees of the company you operate or belong to.</b>														
Base	1005	18	14	13	2	2	18	147	112	47	165	69	34	
0 people	-	-	-	-	-	-	-	-	-	-	-	-	-	
1-9 people	29%	39%	14%	15%	-	50%	33%	51%	21%	6%	4%	16%	3%	
10-49 people	11%	6%	14%	23%	50%	-	6%	14%	16%	15%	11%	9%	6%	
50-99 people	10%	17%	7%	7%	-	-	22%	7%	14%	11%	11%	12%	15%	
100-499 people	19%	-	21%	8%	-	-	11%	15%	22%	36%	25%	22%	12%	
500-999 people	6%	17%	14%	8%	-	-	6%	3%	11%	-	8%	13%	9%	
Over 1,000 people	25%	22%	29%	46%	50%	50%	22%	10%	16%	34%	41%	32%	62%	
Don't know	-	-	-	-	-	-	-	-	-	-	-	-	-	
<b>Q9. How much, if anything do you know about UK Health and Safety Law (the law, regulations, code of conduct, guidelines, etc.)?</b>														
Base	1005	18	14	13	2	2	18	147	112	47	165	69	34	
A great deal	14%	11%	14%	15%	-	-	11%	18%	29%	19%	18%	13%	76%	
A fair amount	47%	89%	86%	85%	100%	100%	89%	82%	71%	81%	82%	87%	24%	
Only a little	30%	-	-	-	-	-	-	-	-	-	-	-	-	
Hardly anything	8%	-	-	-	-	-	-	-	-	-	-	-	-	
Nothing at all	2%	-	-	-	-	-	-	-	-	-	-	-	-	
<b>Q10. When thinking about health and safety regulation in the UK, which of the following most closely resembles your view?</b>														
Base	610	18	14	13	2	2	18	147	112	47	165	69	34	
Too strict	11%	6%	21%	23%	-	-	6%	13%	16%	19%	5%	9%	3%	
Generally appropriate	79%	78%	79%	62%	50%	100%	83%	78%	74%	70%	86%	86%	74%	
Not strict enough	5%	6%	-	15%	-	-	-	3%	4%	6%	5%	1%	12%	
It varies across different areas	6%	11%	-	-	50%	-	11%	6%	6%	4%	4%	4%	12%	
<b>Q11. Still thinking about health and safety regulation in the UK, which of the following most closely resembles your view?</b>														
Base	610	18	14	13	2	2	18	147	112	47	165	69	34	
Regulation is easy to understand and implement	23%	39%	29%	23%	50%	-	17%	24%	21%	26%	20%	23%	29%	
There are some aspects that are difficult to understand, but it can be implemented with guidance	72%	50%	71%	73%	-	100%	83%	69%	73%	72%	75%	72%	71%	
It is too complicated to understand and implement	5%	11%	-	-	50%	-	-	7%	5%	2%	5%	4%	-	
<b>Q12. Since the current Health and Safety at Work Act (HSWA) was enacted in 1974, the number of fatal-injuries in the UK has decreased by more than 80%. What, if anything, do you see as the main reason(s) for this? Please select all that apply</b>														
Base	1005	18	14	13	2	2	18	147	112	47	165	69	34	
Comprehensive hazard prevention standards (i.e. standards that clearly indicate what should be done and what should not be done)	48%	67%	64%	38%	-	50%	39%	52%	49%	49%	56%	43%	44%	
Implementation of a health and safety management system (e.g. the appointment of a health and safety manager)	51%	39%	64%	62%	50%	50%	44%	48%	44%	57%	64%	61%	74%	
Better cooperation and coordination when multiple employers carry out construction at the same location	20%	39%	21%	23%	-	-	22%	23%	20%	23%	19%	22%	35%	
Stronger voluntary efforts of staff and management towards health and safety within the workplace	31%	56%	21%	31%	50%	-	28%	39%	37%	23%	31%	39%	38%	
Allowing businesses sufficient freedoms to enact their own changes	10%	11%	21%	15%	-	-	17%	13%	13%	6%	12%	6%	6%	
Easy to understand the relationship between laws, regulations, code of conduct, and guidance	17%	17%	36%	15%	-	-	22%	20%	18%	30%	19%	17%	18%	



	Familiarity x Occupation							Familiarity x Role						
	Total	Familiar + Skilled trades occupations	Familiar + Caring, leisure and other service occupations	Familiar + Sales and customer service occupations	Familiar + Process, plant and machine operatives	Familiar + Elementary occupations	Familiar + Other	Familiar + Company/Organisation Manager	Familiar + Executive/Board Member	Familiar + Middle Manager (in HRM division)	Familiar + Middle Manager (in other than HRM division)	Familiar + Professionals (other than safety and health related)	Familiar + Professionals (safety and health related)	
So-called three-step approach (First, take essential safety measures, second, take engineering measures for risks that cannot be dealt with by that, and third, take human measures such as education for the remaining risks to prevent industrial accidents) is employed	30%	44%	36%	23%	-	50%	33%	35%	32%	32%	33%	41%	47%	
Employer liability	54%	67%	64%	62%	50%	50%	56%	56%	56%	47%	64%	59%	59%	
Potential fines for employees who breach regulations	32%	28%	29%	31%	-	-	44%	33%	33%	38%	42%	35%	44%	
Measures to prevent occupational accidents (providing safe products, providing information on risks, etc.) are passed throughout the supply chain	52%	78%	57%	54%	-	-	56%	59%	54%	51%	55%	59%	50%	
There is an evaluation and registration system for machinery and chemical substances treated in workplace	26%	44%	29%	23%	50%	-	33%	28%	25%	23%	31%	38%	21%	
Realistic and well-balanced regulations	28%	22%	14%	23%	50%	-	33%	32%	21%	34%	26%	28%	38%	
Under this law, the HSE (Health and Safety Executive) has implemented appropriate health and safety guidance based on high expertise	43%	50%	57%	46%	-	50%	33%	44%	39%	43%	50%	46%	62%	
Regular inspections and guidance from independent health and safety inspectors	37%	39%	50%	38%	50%	-	44%	32%	32%	38%	47%	36%	32%	
Under this law, a safety representative has supported the health and safety management of employers	23%	33%	14%	23%	-	-	17%	24%	30%	28%	24%	25%	26%	
Fines being issued to employers in the past	29%	28%	43%	31%	-	-	39%	30%	32%	23%	33%	32%	41%	
Potential fines for senior management if regulations are violated	38%	33%	43%	38%	-	-	22%	37%	46%	32%	48%	41%	47%	
Other	4%	6%	-	8%	50%	50%	6%	5%	8%	2%	1%	6%	6%	
Don't know	8%	-	-	-	-	-	11%	3%	1%	-	2%	1%	-	
<b>Q13. When thinking about potential changes to the current Health and Safety at Work Act, which of the following issues, if any, do you think need greater focus?</b>	<b>Base</b>	1005	19	14	13	2	2	18	147	112	47	165	69	34
A stronger definition of 'welfare' in the legal context		23%	39%	43%	23%	-	50%	22%	27%	23%	15%	33%	26%	38%
A stronger definition of 'reasonable practicable' in the legal context		27%	22%	50%	8%	50%	50%	17%	28%	29%	32%	38%	29%	50%
Legal nature of the Code of Conduct (ACOP)		11%	22%	-	15%	-	-	6%	10%	13%	9%	15%	19%	21%
A stronger definition of legal obligations imposed on stakeholders (e.g. managers, designers, manufacturers)		23%	33%	21%	15%	-	50%	17%	27%	25%	21%	27%	20%	56%
Stronger definition of risk for those working in spaces where harmful substances are handled		14%	22%	7%	8%	-	-	22%	15%	17%	13%	12%	13%	9%
Stronger assessment of risks posed to workers dealing with chemical substances		19%	33%	21%	31%	-	50%	22%	22%	18%	28%	16%	28%	15%
Stronger management of risks posed to workers dealing with chemical substances (e.g. controlling exposure)		19%	39%	21%	15%	-	50%	33%	17%	14%	30%	19%	25%	18%
Measures to raise management awareness of health and safety regardless of business scale		28%	17%	36%	38%	-	-	22%	35%	26%	26%	35%	20%	44%
Current status/ importance placed on safety specialists in companies and society and measures to improve them		11%	22%	7%	-	-	-	11%	9%	11%	9%	15%	6%	32%
Current status/ importance placed on hygiene specialists in companies and society and measures to improve them		9%	22%	21%	-	-	50%	6%	11%	6%	13%	8%	7%	12%
The appointment of an industrial physician be required by law		5%	22%	-	15%	-	-	-	5%	6%	11%	7%	1%	15%
Introduction of mandatory health checks		17%	33%	29%	23%	50%	-	11%	13%	21%	17%	18%	26%	18%
How to control the safety and health risks of older employees		17%	17%	14%	15%	-	-	17%	13%	13%	15%	21%	16%	18%
Measures to promote cooperation between community and occupational health management		11%	11%	7%	-	-	50%	11%	14%	13%	11%	16%	10%	9%
How safety and health laws and regulations should be for self-employed people such as cloud workers and freelancers		24%	17%	21%	15%	-	50%	17%	23%	27%	23%	24%	26%	41%
Stronger definition on health and safety laws for mobile workers		21%	17%	21%	31%	-	50%	17%	18%	26%	21%	25%	26%	32%
Greater focus on employee mental health		40%	22%	29%	31%	50%	100%	44%	38%	37%	36%	48%	58%	53%
Greater importance of Health and Safety Law in civil cases		12%	11%	36%	8%	-	-	11%	15%	10%	13%	15%	12%	12%
Other		4%	6%	-	8%	-	-	11%	2%	13%	-	1%	6%	9%
Don't know		21%	11%	21%	23%	-	-	22%	16%	10%	6%	12%	6%	3%
<b>Q14. How much importance do you place on health and safety in management?</b>	<b>Base</b>	424	5	2	2	1	-	3	147	112	-	-	-	-
Very important		67%	80%	100%	50%	-	-	33%	77%	72%	-	-	-	-
Moderately important		25%	20%	-	50%	100%	-	33%	20%	22%	-	-	-	-
Neutral		6%	-	-	-	-	-	33%	2%	4%	-	-	-	-
Not very important		1%	-	-	-	-	-	-	1%	1%	-	-	-	-
Not at all important		1%	-	-	-	-	-	-	-	-	-	-	-	-
<b>Q15. You say that health and safety in management is important. Why do you say this? Please select up to three reasons.</b>	<b>Base</b>	390	5	2	2	1	-	2	143	106	-	-	-	-
I do not want the emotional toll of being responsible for an accident		52%	20%	50%	-	100%	-	50%	57%	43%	-	-	-	-
An accident could lead to paying a large compensation		24%	20%	50%	-	-	-	-	19%	28%	-	-	-	-
An accident could negatively affect company morale		36%	20%	50%	50%	-	-	-	38%	42%	-	-	-	-
An accident could negatively affect my company's reputation		47%	-	50%	100%	-	-	100%	49%	58%	-	-	-	-
It is the company policy		27%	40%	-	-	-	-	50%	24%	31%	-	-	-	-
The company has experienced a major industrial accident before		3%	-	-	-	-	-	-	4%	5%	-	-	-	-
I could be punished for violating the law		27%	40%	100%	50%	100%	-	100%	27%	24%	-	-	-	-
An accident could lead to more absenteeism from employees		17%	20%	-	50%	100%	-	-	17%	19%	-	-	-	-
Other		14%	40%	-	50%	-	-	-	14%	15%	-	-	-	-
<b>Q16. In your approach to health and safety, which of the following measures, if any, are you currently taking? Please select up to three.</b>	<b>Base</b>	127	-	-	-	-	-	-	41	55	-	-	-	-
We have dedicated senior managers in charge of health and safety		67%	-	-	-	-	-	-	73%	69%	-	-	-	-
We offer generous remuneration for health and safety specialists		13%	-	-	-	-	-	-	10%	18%	-	-	-	-
A department in charge of safety and health has been set up, and one or more staff members are assigned for every 100 employees		22%	-	-	-	-	-	-	29%	20%	-	-	-	-
We respect the authority of the health and safety specialists within the business		66%	-	-	-	-	-	-	63%	64%	-	-	-	-
The staff assigned to the department in charge of safety and health is reassigned to a central department (personnel department or business management department) of the company or appointed as an officer		33%	-	-	-	-	-	-	32%	38%	-	-	-	-
Other		5%	-	-	-	-	-	-	5%	5%	-	-	-	-
None of these		5%	-	-	-	-	-	-	2%	5%	-	-	-	-
<b>Q17. In your approach to health and safety, which of the following measures, if any, are you currently taking? Please select up to three.</b>	<b>Base</b>	263	5	2	2	1	-	2	102	51	-	-	-	-
We have a health and safety committee		16%	20%	-	-	100%	-	-	17%	29%	-	-	-	-
An independent health and safety expert is invited to participate in the health and safety committee.		11%	20%	-	-	100%	-	-	13%	10%	-	-	-	-
A health and safety assistant has been appointed within the company		28%	-	-	-	-	-	50%	28%	37%	-	-	-	-
We have commissioned an external health and safety consultant to conduct a workplace assessment and issue guidance		22%	20%	-	-	100%	-	-	23%	31%	-	-	-	-
Other		10%	40%	-	100%	-	-	-	14%	6%	-	-	-	-
None of these		37%	40%	100%	-	-	-	50%	31%	24%	-	-	-	-
<b>Q18. You say that health and safety in management is not important. Why do you say this? Please select up to 3 reasons.</b>	<b>Base</b>	10	-	-	-	-	-	-	1	1	-	-	-	-
We believe accidents are inevitable in the workplace and cannot be prevented		30%	-	-	-	-	-	-	-	100%	-	-	-	-
In the event of an accident, it is unlikely we will be required to pay compensation		30%	-	-	-	-	-	-	-	100%	-	-	-	-
In the event of an accident, it is unlikely to negatively affect staff morale		10%	-	-	-	-	-	-	-	-	-	-	-	-
In the event of an accident, our reputation will not suffer		20%	-	-	-	-	-	-	-	-	-	-	-	-
Staff do not place importance on health and safety		-	-	-	-	-	-	-	-	-	-	-	-	-
Because the current top management does not place much importance to it		-	-	-	-	-	-	-	-	-	-	-	-	-
Because previous top management did not place much importance to it		-	-	-	-	-	-	-	-	-	-	-	-	-
Because the company has hardly / never experienced an accident		40%	-	-	-	-	-	-	-	100%	-	-	-	-
Even if it is punished by law, it will not be a big disadvantage		20%	-	-	-	-	-	-	-	-	-	-	-	-
Other		20%	-	-	-	-	-	-	100%	-	-	-	-	-

**Kindai University Osaka**  
**Health & Safety survey**

Fieldwork Dates: 9th - 18th December 2020



	Total	Familiar + Subordinate (in HRM division)	Familiar + Subordinate (in other than HRM division)	Familiar + Others	Familiar + not applicable - I don't have any management responsibility	Familiar + Agriculture	Familiar + Forestry	Familiar + Fisheries	Familiar + Mining	Familiar + Construction industry	Familiar + Manufacturing industry	Familiar + Electricity, gas, heat supply, water supply	Familiar + Information and communication industries
<b>Q1. Please answer your gender</b>													
Base	1005	2	4	18	12	5	2	-	1	43	73	11	32
Male	62%	-	100%	78%	67%	80%	100%	-	100%	70%	82%	100%	81%
Female	38%	100%	-	22%	33%	20%	-	-	-	30%	18%	-	19%
<b>Q2. Age</b>													
Base	1005	2	4	18	12	5	2	-	1	43	73	11	32
20s	3%	-	-	-	-	-	-	-	-	2%	3%	-	6%
30s	18%	-	25%	6%	25%	-	50%	-	-	21%	14%	-	9%
40s	24%	50%	-	28%	17%	20%	-	-	-	19%	21%	18%	19%
50s	33%	50%	25%	17%	8%	40%	50%	-	100%	35%	40%	36%	31%
60s and over	22%	-	50%	50%	50%	40%	-	-	-	23%	23%	45%	34%
<b>Q3. Nation</b>													
Base	1005	2	4	18	12	5	2	-	1	43	73	11	32
England	85%	50%	50%	94%	75%	80%	50%	-	100%	74%	90%	100%	88%
Wales	3%	50%	-	-	8%	-	50%	-	-	2%	5%	-	3%
Scotland	10%	-	50%	6%	8%	20%	-	-	-	23%	3%	-	6%
Northern Ireland	2%	-	-	-	8%	-	-	-	-	-	1%	-	3%
<b>Q4. Please answer your occupation.</b>													
Base	1005	2	4	18	12	5	2	-	1	43	73	11	32
Managers, executives and senior officials	57%	50%	25%	39%	8%	20%	-	-	-	42%	74%	45%	60%
Professional occupations	20%	-	25%	11%	33%	20%	-	-	-	23%	8%	18%	28%
Associate professional and technical occupations	6%	-	-	6%	-	20%	50%	-	-	14%	4%	27%	6%
Administrative and secretarial occupations	3%	50%	-	-	8%	-	-	-	-	2%	1%	-	-
Skilled trades occupations	3%	-	25%	11%	8%	40%	50%	-	100%	7%	7%	9%	-
Caring, leisure and other service occupations	3%	-	25%	-	8%	-	-	-	-	-	-	-	-
Sales and customer service occupations	2%	-	-	17%	8%	-	-	-	-	2%	3%	-	-
Process, plant and machine operatives	0%	-	-	-	-	-	-	-	-	2%	1%	-	-
Elementary occupations	0%	-	-	-	-	-	-	-	-	2%	-	-	-
Other	5%	-	-	17%	25%	-	-	-	-	-	1%	-	-
Not Applicable - I don't work	0%	-	-	-	-	-	-	-	-	-	-	-	-
<b>Q5. Please tell us about your position within the company you operate or belong to.</b>													
Base	1005	2	4	18	12	5	2	-	1	43	73	11	32
Company/Organization Manager	25%	-	-	-	-	20%	-	-	-	23%	19%	9%	34%
Executive/Board Member	17%	-	-	-	-	20%	-	-	-	16%	32%	-	28%
Middle Manager (in HRM division)	6%	-	-	-	-	-	-	-	-	12%	5%	9%	3%
Middle Manager (in other than HRM division)	27%	-	-	-	-	20%	-	-	-	7%	27%	27%	16%
Professionals (other than safety and health related)	11%	-	-	-	-	40%	50%	-	-	30%	7%	27%	13%
Professionals (safety and health related)	4%	-	-	-	-	-	-	-	-	7%	5%	27%	-
Subordinate (in HRM division)	0%	100%	-	-	-	-	-	-	-	-	-	-	-
Subordinate (in other than HRM division)	1%	-	100%	-	-	-	50%	-	-	-	-	-	-
Others	6%	-	-	100%	-	-	-	-	-	5%	3%	-	6%
Not applicable - I don't have any management responsibility.	3%	-	-	-	100%	-	-	-	100%	-	1%	-	-
<b>Q6. Please tell us about the type of business of the company you operate or belong to. If there are multiple applicable industries, please answer the one that you are mainly involved in.</b>													
Base	1005	2	4	18	12	5	2	-	1	43	73	11	32
Agriculture	1%	-	-	-	-	100%	-	-	-	-	-	-	-
Forestry	0%	-	25%	-	-	-	100%	-	-	-	-	-	-
Fisheries	0%	-	-	-	-	-	-	-	-	-	-	-	-
Mining	0%	-	-	-	8%	-	-	-	100%	-	-	-	-
Construction industry	6%	-	-	11%	-	-	-	-	-	100%	-	-	-
Manufacturing industry	10%	-	-	11%	8%	-	-	-	-	-	100%	-	-
Electricity, gas, heat supply, water supply	1%	-	-	-	-	-	-	-	-	-	-	100%	-
Information and communication industry	6%	-	-	11%	-	-	-	-	-	-	-	-	100%
Transportation industry	3%	-	-	-	-	-	-	-	-	-	-	-	-
Wholesale / Retail	6%	-	-	11%	8%	-	-	-	-	-	-	-	-
Finance / Insurance	3%	-	-	8%	-	-	-	-	-	-	-	-	-
Real estate industry	4%	-	25%	-	-	-	-	-	-	-	-	-	-
Restaurant / accommodation business	4%	-	25%	11%	-	-	-	-	-	-	-	-	-
Medical and welfare	7%	-	25%	6%	17%	-	-	-	-	-	-	-	-
Education / learning support	14%	50%	-	11%	8%	-	-	-	-	-	-	-	-
Service industry (not classified elsewhere)	7%	-	-	6%	8%	-	-	-	-	-	-	-	-
National institutions (those not classified elsewhere)	2%	-	-	-	-	-	-	-	-	-	-	-	-
Local government (not classified elsewhere)	4%	-	-	-	8%	-	-	-	-	-	-	-	-
Others	21%	50%	-	22%	25%	-	-	-	-	-	-	-	-
<b>Q7. Are you involved in work related to the health and of the company to which you operate or belong to?</b>													
Base	1005	2	4	18	12	5	2	-	1	43	73	11	32
Directly involved	51%	50%	25%	22%	8%	60%	50%	-	-	74%	62%	64%	66%
Indirectly involved	36%	50%	75%	50%	42%	20%	50%	-	100%	19%	32%	36%	25%
Not involved	14%	-	-	28%	50%	20%	-	-	-	7%	7%	-	9%
<b>Q8. Please tell us about the number of employees of the company you operate or belong to.</b>													
Base	1005	2	4	18	12	5	2	-	1	43	73	11	32
0 people	-	-	-	-	-	-	-	-	-	-	-	-	-
1-9 people	29%	-	50%	33%	42%	60%	-	-	100%	28%	18%	27%	47%
10-49 people	11%	-	-	6%	17%	-	-	-	-	7%	14%	-	3%
50-99 people	10%	-	-	6%	8%	20%	-	-	-	12%	14%	-	13%
100-499 people	19%	50%	-	11%	8%	20%	-	-	-	23%	27%	27%	13%
500-999 people	6%	50%	-	11%	-	-	50%	-	-	7%	11%	9%	13%
Over 1,000 people	25%	-	50%	33%	25%	-	50%	-	-	23%	16%	36%	13%
Don't know	-	-	-	-	-	-	-	-	-	-	-	-	-
<b>Q9. How much, if anything do you know about UK Health and Safety Law (the law, regulations, code of conduct, guidelines, etc.)?</b>													
Base	1005	2	4	18	12	5	2	-	1	43	73	11	32
A great deal	14%	50%	25%	17%	8%	20%	-	-	-	35%	22%	45%	22%
A fair amount	47%	50%	75%	83%	92%	80%	100%	-	100%	65%	78%	55%	78%
Only a little	30%	-	-	-	-	-	-	-	-	-	-	-	-
Hardly anything	8%	-	-	-	-	-	-	-	-	-	-	-	-
Nothing at all	2%	-	-	-	-	-	-	-	-	-	-	-	-
<b>Q10. When thinking about health and safety regulation in the UK, which of the following most closely resembles your view?</b>													
Base	610	2	4	18	12	5	2	-	1	43	73	11	32
Too strict	11%	-	25%	33%	-	20%	-	-	-	9%	15%	-	22%
Generally appropriate	79%	100%	25%	50%	92%	80%	-	-	100%	79%	77%	82%	63%
Not strict enough	5%	-	25%	11%	-	-	-	-	-	-	3%	-	9%
It varies across different areas	6%	-	25%	6%	8%	-	100%	-	-	12%	5%	18%	6%
<b>Q11. Still thinking about health and safety regulation in the UK, which of the following most closely resembles your view?</b>													
Base	610	2	4	18	12	5	2	-	1	43	73	11	32
Regulation is easy to understand and implement	23%	50%	-	28%	17%	40%	-	-	-	35%	21%	18%	19%
There are some aspects that are difficult to understand, but it can be implemented with guidance	72%	50%	75%	67%	83%	60%	50%	-	100%	63%	71%	82%	72%
It is too complicated to understand and implement	5%	-	25%	6%	-	-	50%	-	-	2%	8%	-	9%
<b>Q12. Since the current Health and Safety at Work Act (HSWA) was enacted in 1974, the number of fatal-injuries in the UK has decreased by more than 80%. What, if anything, do you see as the main reason(s) for this? Please select all that apply</b>													
Base	1005	2	4	18	12	5	2	-	1	43	73	11	32
Comprehensive hazard prevention standards (i.e. standards that clearly indicate what should be done and what should not be done)	48%	50%	25%	39%	75%	40%	50%	-	-	49%	45%	82%	38%
Implementation of a health and safety management system (e.g. the appointment of a health and safety manager)	51%	100%	-	67%	58%	-	50%	-	-	47%	52%	73%	41%
Better cooperation and coordination when multiple employers carry out construction at the same location	20%	-	-	44%	33%	-	-	-	-	35%	16%	45%	25%
Stronger voluntary efforts of staff and management towards health and safety within the workplace	31%	50%	75%	39%	33%	20%	50%	-	-	28%	33%	36%	38%
Allowing businesses sufficient freedoms to enact their own changes	10%	-	25%	17%	17%	-	-	-	-	7%	16%	18%	19%
Easy to understand the relationship between laws, regulations, code of conduct, and guidance	17%	-	25%	22%	17%	-	50%	-	-	12%	14%	45%	13%

**Kindai University Osaka**  
**Health & Safety survey**

Fieldwork Dates: 9th - 18th December 2020



	Total					Familiar + Agriculture	Familiar + Forestry	Familiar + Fisheries	Familiar + Mining	Familiar + Construction industry	Familiar + Manufacturing industry	Familiar + Electricity, gas, heat supply, water supply	Familiar + Information and communication industries
		Familiar + Subordinate (in HRM division)	Familiar + Subordinate (in other than HRM division)	Familiar + Others	Familiar + not applicable - I don't have any management responsibility								
So-called three-step approach (First, take essential safety measures, second, take engineering measures for risks that cannot be dealt with by that, and third, take human measures such as education for the remaining risks to prevent industrial accidents) is employed	30%	50%	50%	22%	50%	40%	50%	-	-	37%	34%	55%	38%
Employer liability	54%	100%	75%	67%	58%	20%	50%	-	-	49%	52%	82%	63%
Potential fines for employees who breach regulations	32%	50%	25%	39%	25%	-	-	-	-	28%	36%	45%	38%
Measures to prevent occupational accidents (providing safe products, providing information on risks, etc.) are passed throughout the supply chain	52%	100%	75%	50%	75%	40%	50%	-	100%	51%	51%	64%	50%
There is an evaluation and registration system for machinery and chemical substances treated in workplace	26%	50%	50%	39%	33%	40%	50%	-	-	21%	30%	36%	44%
Realistic and well-balanced regulations	28%	50%	25%	44%	50%	20%	-	-	-	30%	19%	36%	25%
Under this law, the HSE (Health and Safety Executive) has implemented appropriate health and safety guidance based on high expertise	43%	100%	50%	33%	75%	40%	-	100%	-	40%	37%	55%	41%
Regular inspections and guidance from independent health and safety inspectors	37%	-	50%	39%	75%	-	50%	-	100%	33%	34%	55%	31%
Under this law, a safety representative has supported the health and safety management of employers	23%	-	25%	39%	33%	-	-	-	-	12%	25%	55%	25%
Fines being issued to employees in the past	29%	50%	25%	33%	17%	20%	100%	-	-	14%	30%	55%	31%
Potential fines for senior management if regulations are violated	38%	50%	50%	33%	42%	20%	100%	-	-	40%	37%	64%	38%
Other	4%	-	-	6%	-	20%	-	-	-	9%	8%	9%	9%
Don't know	8%	-	-	17%	8%	-	-	-	-	2%	1%	-	3%

**Q13. When thinking about potential changes to the current Health and Safety at Work Act, which of the following issues, if any, do you think need greater focus?**

Base	1005	2	4	18	12	5	2	-	1	43	73	11	32
A stronger definition of 'welfare' in the legal context	23%	50%	25%	33%	25%	20%	50%	-	-	35%	21%	36%	28%
A stronger definition of 'reasonable practicable' in the legal context	27%	-	25%	28%	33%	-	50%	-	-	28%	32%	45%	34%
Legal nature of the Code of Conduct (ACOP)	11%	50%	25%	17%	8%	-	50%	-	-	14%	10%	36%	13%
A stronger definition of legal obligations imposed on stakeholders (e.g. managers, designers, manufacturers)	23%	-	50%	33%	8%	-	50%	-	-	28%	32%	55%	31%
Stronger definition of risk for those working in spaces where harmful substances are handled	14%	-	50%	28%	25%	-	50%	-	-	14%	10%	18%	31%
Stronger assessment of risks posed to workers dealing with chemical substances	19%	-	75%	33%	33%	-	50%	-	-	23%	26%	18%	28%
Stronger management of risks posed to workers dealing with chemical substances (e.g. controlling exposure)	19%	-	50%	28%	33%	20%	50%	-	-	16%	25%	9%	31%
Measures to raise management awareness of health and safety regardless of business scale	28%	50%	50%	33%	33%	-	-	-	-	35%	27%	27%	34%
Current status/ importance placed on safety specialists in companies and society and measures to improve them	11%	50%	25%	22%	33%	-	-	-	100%	16%	12%	-	13%
Current status/ importance placed on hygiene specialists in companies and society and measures to improve them	9%	50%	-	17%	17%	20%	-	-	-	7%	11%	-	16%
The appointment of an industrial physician be required by law	5%	-	25%	6%	-	-	50%	-	-	7%	7%	-	6%
Introduction of mandatory health checks	17%	-	25%	11%	33%	-	-	-	-	14%	25%	9%	13%
How to control the safety and health risks of older employees	17%	50%	50%	22%	33%	-	50%	-	-	7%	22%	9%	22%
Measures to promote cooperation between community and occupational health management	11%	50%	25%	11%	25%	-	-	-	100%	14%	14%	9%	16%
How safety and health laws and regulations should be for self-employed people such as cloud workers and freelancers	24%	100%	25%	22%	42%	20%	50%	-	-	30%	21%	36%	47%
Stronger definition on health and safety laws for mobile workers	21%	50%	25%	11%	33%	-	-	-	-	16%	22%	45%	31%
Greater focus on employee mental health	40%	100%	25%	28%	50%	-	50%	-	-	47%	36%	55%	44%
Greater importance of Health and Safety Law in civil cases	12%	50%	-	28%	8%	20%	-	-	-	12%	1%	-	25%
Other	4%	-	-	11%	-	20%	50%	-	-	5%	8%	27%	9%
Don't know	21%	-	25%	33%	25%	40%	-	-	-	7%	7%	-	19%

**Q14. How much importance do you place on health and safety in management?**

Base	424	-	-	-	-	2	-	-	-	17	37	1	20
Very important	67%	-	-	-	-	50%	-	-	-	71%	70%	100%	65%
Moderately important	25%	-	-	-	-	50%	-	-	-	29%	30%	-	25%
Neutral	6%	-	-	-	-	-	-	-	-	-	-	-	10%
Not very important	1%	-	-	-	-	-	-	-	-	-	-	-	-
Not at all important	1%	-	-	-	-	-	-	-	-	-	-	-	-

**Q15. You say that health and safety in management is important. Why do you say this? Please select up to three reasons.**

Base	390	-	-	-	-	2	-	-	-	17	37	1	18
I do not want the emotional toll of being responsible for an accident	52%	-	-	-	-	-	-	-	-	53%	46%	100%	50%
An accident could lead to paying a large compensation	24%	-	-	-	-	50%	-	-	-	24%	22%	-	11%
An accident could negatively affect company morale	36%	-	-	-	-	50%	-	-	-	47%	43%	-	17%
An accident could negatively affect my company's reputation	47%	-	-	-	-	-	-	-	-	41%	49%	100%	56%
It is the company policy	27%	-	-	-	-	-	-	-	-	24%	35%	100%	44%
The company has experienced a major industrial accident before	3%	-	-	-	-	-	-	-	-	12%	3%	-	6%
I could be punished for violating the law	27%	-	-	-	-	-	-	-	-	24%	38%	-	17%
An accident could lead to more absenteeism from employees	17%	-	-	-	-	-	-	-	-	24%	22%	-	11%
Other	14%	-	-	-	-	50%	-	-	-	18%	8%	-	33%

**Q16. In your approach to health and safety, which of the following measures, if any, are you currently taking? Please select up to three.**

Base	127	-	-	-	-	-	-	-	-	9	14	-	7
We have dedicated senior managers in charge of health and safety	67%	-	-	-	-	-	-	-	-	67%	86%	-	57%
We offer generous remuneration for health and safety specialists	13%	-	-	-	-	-	-	-	-	22%	-	-	43%
A department in charge of safety and health has been set up, and one or more staff members are assigned for every 100 employees	22%	-	-	-	-	-	-	-	-	22%	29%	-	43%
We respect the authority of the health and safety specialists within the business	66%	-	-	-	-	-	-	-	-	89%	71%	-	57%
The staff assigned to the department in charge of safety and health is reassigned to a central department (personnel department or business management department) of the company or appointed as an officer	33%	-	-	-	-	-	-	-	-	44%	14%	-	43%
Other	5%	-	-	-	-	-	-	-	-	-	14%	-	-
None of these	5%	-	-	-	-	-	-	-	-	-	7%	-	-

**Q17. In your approach to health and safety, which of the following measures, if any, are you currently taking? Please select up to three.**

Base	263	-	-	-	-	2	-	-	-	8	23	1	11
We have a health and safety committee	16%	-	-	-	-	-	-	-	-	38%	35%	-	36%
An independent health and safety expert is invited to participate in the health and safety committee	11%	-	-	-	-	-	-	-	-	13%	9%	-	-
A health and safety assistant has been appointed within the company	28%	-	-	-	-	50%	-	-	-	25%	30%	-	27%
We have commissioned an external health and safety consultant to conduct a workplace assessment and issue guidance	22%	-	-	-	-	-	-	-	-	38%	35%	-	9%
Other	10%	-	-	-	-	50%	-	-	-	13%	4%	100%	16%
None of these	37%	-	-	-	-	-	-	-	-	13%	30%	-	36%

**Q18. You say that health and safety in management is not important. Why do you say this? Please select up to 3 reasons.**

Base	10	-	-	-	-	-	-	-	-	-	-	-	-
We believe accidents are inevitable in the workplace and cannot be prevented	30%	-	-	-	-	-	-	-	-	-	-	-	-
In the event of an accident, it is unlikely we will be required to pay compensation	30%	-	-	-	-	-	-	-	-	-	-	-	-
In the event of an accident, it is unlikely to negatively affect staff morale	10%	-	-	-	-	-	-	-	-	-	-	-	-
In the event of an accident, our reputation will not suffer	20%	-	-	-	-	-	-	-	-	-	-	-	-
Staff do not place importance on health and safety	-	-	-	-	-	-	-	-	-	-	-	-	-
Because the current top management does not place much importance to it	-	-	-	-	-	-	-	-	-	-	-	-	-
Because previous top management did not place much importance to it	-	-	-	-	-	-	-	-	-	-	-	-	-
Because the company has hardly / never experienced an accident	40%	-	-	-	-	-	-	-	-	-	-	-	-
Even if it is punished by law, it will not be a big disadvantage	20%	-	-	-	-	-	-	-	-	-	-	-	-
Other	20%	-	-	-	-	-	-	-	-	-	-	-	-

Cell Contents (C)

**Kindai University Osaka**  
**Health & Safety survey**

Fieldwork Dates: 9th - 18th December 2020



	Total	Familiar x Industry											Far
		Familiar + Transportation industry	Familiar + Wholesale / Retail	Familiar + Finance / Insurance	Familiar + Real estate industry	Familiar + Restaurant / accommodation business	Familiar + Medical and welfare	Familiar + Education / learning support	Familiar + Service industry (not classified elsewhere)	Familiar + National institutions (those not classified elsewhere)	Familiar + Local government (not classified elsewhere)	Familiar + Others	
<b>Q1. Please answer your gender</b>													
Base	1005	17	37	16	25	24	39	89	51	9	20	116	377
Male	62%	76%	76%	75%	76%	42%	62%	54%	63%	7%	75%	58%	65%
Female	38%	24%	24%	25%	24%	58%	38%	46%	37%	22%	25%	42%	35%
<b>Q2. Age</b>													
Base	1005	17	37	16	25	24	39	89	51	9	20	116	377
20s	3%	-	5%	-	-	21%	3%	-	6%	-	5%	3%	3%
30s	18%	-	30%	38%	12%	29%	23%	16%	8%	44%	5%	12%	17%
40s	24%	24%	19%	19%	25%	29%	18%	30%	20%	22%	10%	25%	23%
50s	33%	59%	30%	25%	32%	13%	28%	36%	49%	33%	60%	34%	38%
60s and over	22%	18%	16%	13%	24%	8%	28%	18%	18%	-	20%	27%	19%
<b>Q3. Nation</b>													
Base	1005	17	37	16	25	24	39	89	51	9	20	116	377
England	85%	88%	84%	63%	76%	83%	90%	91%	90%	89%	85%	87%	87%
Wales	3%	-	-	6%	-	4%	5%	3%	2%	-	5%	3%	3%
Scotland	10%	6%	8%	25%	24%	13%	5%	4%	8%	11%	10%	7%	7%
Northern Ireland	2%	6%	8%	6%	-	-	-	1%	-	-	-	3%	2%
<b>Q4. Please answer your occupation.</b>													
Base	1005	17	37	16	25	24	39	89	51	9	20	116	377
Managers, executives and senior officials	57%	71%	70%	63%	64%	50%	64%	60%	71%	22%	80%	61%	67%
Professional occupations	20%	12%	3%	31%	20%	4%	23%	28%	18%	67%	10%	16%	18%
Associate professional and technical occupations	6%	16%	8%	-	8%	-	-	6%	4%	-	-	3%	7%
Administrative and secretarial occupations	3%	-	-	-	4%	-	-	-	4%	-	10%	7%	2%
Skilled trades occupations	3%	-	-	-	8%	-	-	-	-	-	-	3%	2%
Caring, leisure and other service occupations	3%	-	-	6%	4%	17%	8%	1%	-	-	-	3%	3%
Sales and customer service occupations	2%	-	14%	-	-	4%	-	-	4%	-	-	2%	1%
Process, plant and machine operatives	0%	-	-	-	-	-	-	-	-	-	-	-	-
Elementary occupations	0%	-	-	-	-	-	-	1%	-	-	-	-	-
Other	5%	-	5%	-	4%	4%	5%	4%	-	11%	-	5%	2%
Not Applicable - I don't work	0%	-	-	-	-	-	-	-	-	-	-	-	-
<b>Q5. Please tell us about your position within the company you operate or belong to.</b>													
Base	1005	17	37	16	25	24	39	89	51	9	20	116	377
Company/Organization Manager	25%	18%	35%	-	16%	13%	13%	16%	49%	22%	5%	34%	29%
Executive/Board Member	17%	24%	11%	38%	16%	8%	21%	19%	20%	-	15%	12%	22%
Middle Manager (in HRM division)	6%	12%	16%	6%	4%	4%	5%	8%	6%	11%	5%	9%	9%
Middle Manager (in other than HRM division)	27%	24%	19%	19%	48%	54%	28%	33%	20%	44%	45%	27%	21%
Professionals (other than safety and health related)	11%	12%	8%	25%	8%	8%	10%	15%	-	22%	10%	6%	8%
Professionals (safety and health related)	4%	12%	3%	6%	4%	-	13%	6%	2%	-	15%	4%	8%
Subordinate (in HRM division)	0%	-	-	-	-	-	-	1%	-	-	-	1%	0%
Subordinate (in other than HRM division)	1%	-	-	4%	4%	3%	3%	-	-	-	-	4%	0%
Others	6%	-	5%	-	8%	3%	2%	2%	-	-	-	3%	1%
Not applicable - I don't have any management responsibility.	3%	-	3%	6%	-	-	5%	1%	2%	-	5%	3%	0%
<b>Q6. Please tell us about the type of business of the company you operate or belong to. If there are multiple applicable industries, please answer the one that you are mainly involved in.</b>													
Base	1005	17	37	16	25	24	39	89	51	9	20	116	377
Agriculture	1%	-	-	-	-	-	-	-	-	-	-	-	1%
Forestry	0%	-	-	-	-	-	-	-	-	-	-	-	0%
Fisheries	0%	-	-	-	-	-	-	-	-	-	-	-	-
Mining	0%	-	-	-	-	-	-	-	-	-	-	-	-
Construction industry	6%	-	-	-	-	-	-	-	-	-	-	-	8%
Manufacturing industry	10%	-	-	-	-	-	-	-	-	-	-	-	12%
Electricity, gas, heat supply, water supply	1%	-	-	-	-	-	-	-	-	-	-	-	2%
Information and communication industry	6%	-	-	-	-	-	-	-	-	-	-	-	6%
Transportation industry	3%	100%	-	-	-	-	-	-	-	-	-	-	3%
Wholesale / Retail	6%	-	100%	-	-	-	-	-	-	-	-	-	6%
Finance / Insurance	3%	-	-	100%	-	-	-	-	-	-	-	-	2%
Real estate industry	4%	-	-	-	100%	-	-	-	-	-	-	-	5%
Restaurant / accommodation business	4%	-	-	-	-	100%	-	-	-	-	-	-	2%
Medical and welfare	7%	-	-	-	-	-	100%	-	-	-	-	-	8%
Education / learning support	14%	-	-	-	-	-	-	100%	-	-	-	-	15%
Service industry (not classified elsewhere)	7%	-	-	-	-	-	-	-	100%	-	-	-	9%
National institutions (those not classified elsewhere)	2%	-	-	-	-	-	-	-	-	100%	-	-	2%
Local government (not classified elsewhere)	4%	-	-	-	-	-	-	-	-	-	100%	-	3%
Others	21%	-	-	-	-	-	-	-	-	-	-	100%	18%
<b>Q7. Are you involved in work related to the health and of the company to which you operate or belong?</b>													
Base	1005	17	37	16	25	24	39	89	51	9	20	116	377
Directly involved	51%	59%	57%	56%	68%	38%	77%	62%	65%	67%	55%	58%	100%
Indirectly involved	36%	35%	41%	31%	24%	42%	21%	31%	27%	33%	49%	38%	-
Not involved	14%	6%	3%	13%	8%	21%	3%	7%	8%	-	-	4%	-
<b>Q8. Please tell us about the number of employees of the company you operate or belong to.</b>													
Base	1005	17	37	16	25	24	39	89	51	9	20	116	377
0 people	-	-	-	-	-	-	-	-	-	-	-	-	-
1-9 people	29%	6%	22%	19%	28%	8%	18%	9%	37%	-	-	26%	25%
10-49 people	11%	6%	22%	6%	8%	13%	10%	11%	14%	-	-	17%	12%
50-99 people	10%	6%	13%	12%	8%	12%	13%	12%	12%	-	-	11%	11%
100-499 people	19%	35%	24%	19%	24%	17%	13%	29%	16%	11%	20%	16%	22%
500-999 people	6%	-	3%	6%	4%	13%	5%	7%	6%	-	10%	7%	7%
Over 1,000 people	25%	47%	30%	38%	24%	42%	41%	30%	16%	89%	70%	22%	23%
Don't know	-	-	-	-	-	-	-	-	-	-	-	-	-
<b>Q9. How much, if anything do you know about UK Health and Safety Law (the law, regulations, code of conduct, guidelines, etc.)?</b>													
Base	1005	17	37	16	25	24	39	89	51	9	20	116	377
A great deal	14%	24%	24%	19%	24%	13%	15%	20%	27%	33%	35%	20%	30%
A fair amount	47%	76%	76%	81%	76%	88%	85%	80%	73%	67%	65%	80%	70%
Only a little	30%	-	-	-	-	-	-	-	-	-	-	-	-
Hardly anything	8%	-	-	-	-	-	-	-	-	-	-	-	-
Nothing at all	2%	-	-	-	-	-	-	-	-	-	-	-	-
<b>Q10. When thinking about health and safety regulation in the UK, which of the following most closely resembles your view?</b>													
Base	610	17	37	16	25	24	39	89	51	9	20	116	377
Too strict	11%	18%	14%	6%	20%	13%	18%	3%	16%	22%	-	7%	12%
Generally appropriate	79%	82%	73%	75%	80%	75%	69%	92%	65%	78%	80%	85%	77%
Not strict enough	5%	-	5%	13%	-	8%	8%	1%	14%	-	15%	3%	5%
It varies across different areas	6%	-	8%	6%	-	4%	5%	3%	6%	-	5%	4%	5%
<b>Q11. Still thinking about health and safety regulation in the UK, which of the following most closely resembles your view?</b>													
Base	610	17	37	16	25	24	39	89	51	9	20	116	377
Regulation is easy to understand and implement	23%	6%	24%	19%	16%	17%	23%	22%	22%	11%	25%	28%	25%
There are some aspects that are difficult to understand, but it can be implemented with guidance	72%	82%	73%	75%	76%	79%	72%	74%	71%	78%	75%	70%	71%
It is too complicated to understand and implement	5%	12%	3%	6%	8%	4%	5%	3%	8%	11%	-	3%	5%
<b>Q12. Since the current Health and Safety at Work Act (HSWA) was enacted in 1974, the number of fatal-injuries in the UK has decreased by more than 80%. What, if anything, do you see as the main reason(s) for this? Please select all that apply</b>													
Base	1005	17	37	16	25	24	39	89	51	9	20	116	377
Comprehensive hazard prevention standards (i.e. standards that clearly indicate what should be done and what should not be done)	48%	47%	59%	63%	52%	58%	46%	53%	41%	56%	60%	53%	53%
Implementation of a health and safety management system (e.g. the appointment of a health and safety manager)	51%	65%	54%	56%	60%	67%	59%	60%	37%	67%	90%	61%	57%
Better cooperation and coordination when multiple employers carry out construction at the same location	20%	29%	24%	31%	44%	17%	26%	21%	14%	22%	25%	18%	24%
Stronger voluntary efforts of staff and management towards health and safety within the workplace	31%	24%	38%	44%	40%	42%	46%	35%	31%	22%	35%	36%	35%
Allowing businesses sufficient freedoms to enact their own changes	10%	6%	14%	25%	12%	8%	13%	3%	14%	-	15%	10%	12%
Easy to understand the relationship between laws, regulations, code of conduct, and guidance	17%	12%	11%	19%	24%	25%	28%	20%	16%	11%	25%	26%	21%



Total	Familiar x Industry											Far	
	Familiar + Transportation industry	Familiar + Wholesale / Retail	Familiar + Finance / Insurance	Familiar + Real estate industry	Familiar + Restaurant / accommodation business	Familiar + Medical and welfare	Familiar + Education / learning support	Familiar + Service industry (not classified elsewhere)	Familiar + National institutions (those not classified elsewhere)	Familiar + Local government (not classified elsewhere)	Familiar + Others		Familiar + Directly involved
So-called three-step approach (First, take essential safety measures, second, take engineering measures for risks that cannot be dealt with by that, and third, take human measures such as education for the remaining risks to prevent industrial accidents) is employed	30%	41%	46%	44%	36%	25%	38%	31%	18%	44%	50%	34%	36%
Employer liability	54%	71%	70%	75%	68%	71%	51%	60%	45%	67%	55%	62%	56%
Potential fines for employees who breach regulations	32%	41%	30%	50%	52%	58%	54%	29%	22%	11%	45%	41%	37%
Measures to prevent occupational accidents (providing safe products, providing information on risks, etc.) are passed throughout the supply chain	52%	59%	51%	38%	68%	75%	62%	64%	43%	67%	60%	57%	54%
There is an evaluation and registration system for machinery and chemical substances treated in workplaces	26%	35%	30%	25%	32%	33%	33%	26%	16%	56%	15%	32%	28%
Realistic and well-balanced regulations	28%	24%	27%	31%	32%	38%	33%	28%	24%	22%	45%	35%	31%
Under this law, the HSE (Health and Safety Executive) has implemented appropriate health and safety guidance based on high expertise	43%	41%	46%	56%	52%	58%	46%	43%	37%	44%	50%	59%	47%
Regular inspections and guidance from independent health and safety inspectors	37%	41%	38%	44%	44%	50%	46%	37%	25%	33%	50%	41%	37%
Under this law, a safety representative has supported the health and safety management of employers	23%	29%	16%	31%	40%	42%	28%	26%	18%	33%	45%	28%	27%
Fines being issued to employers in the past	29%	35%	27%	56%	36%	54%	41%	27%	20%	33%	35%	32%	32%
Potential fines for senior management if regulations are violated	38%	47%	24%	63%	60%	42%	49%	33%	39%	33%	45%	51%	41%
Other	4%	-	3%	-	-	-	3%	1%	4%	1%	5%	3%	4%
Don't know	8%	-	5%	-	4%	-	-	4%	4%	-	-	2%	2%
<b>Q13. When thinking about potential changes to the current Health and Safety at Work Act, which of the following issues, if any, do you think need greater focus?</b>													
Base	1005	17	37	16	25	24	39	89	51	9	20	116	377
A stronger definition of 'welfare' in the legal context	23%	29%	27%	50%	16%	42%	23%	29%	20%	33%	45%	26%	29%
A stronger definition of 'reasonable practicable' in the legal context	27%	47%	24%	25%	44%	25%	46%	27%	20%	22%	60%	37%	35%
Legal nature of the Code of Conduct (ACOP)	11%	6%	16%	19%	20%	21%	10%	13%	12%	11%	30%	12%	14%
A stronger definition of legal obligations imposed on stakeholders (e.g. managers, designers, manufacturers)	23%	41%	32%	44%	24%	17%	23%	22%	22%	11%	40%	24%	29%
Stronger definition of risk for those working in spaces where harmful substances are handled	14%	35%	16%	19%	20%	21%	13%	8%	8%	22%	10%	15%	15%
Stronger assessment of risks posed to workers dealing with chemical substances	19%	35%	30%	13%	20%	29%	26%	13%	14%	22%	25%	18%	21%
Stronger management of risks posed to workers dealing with chemical substances (e.g. controlling exposure)	19%	35%	27%	19%	32%	25%	23%	13%	10%	11%	10%	18%	19%
Measures to raise management awareness of health and safety regardless of business scale	28%	41%	41%	44%	36%	21%	38%	22%	31%	11%	40%	34%	32%
Current status/ importance placed on safety specialists in companies and society and measures to improve them	11%	12%	5%	38%	4%	13%	13%	8%	10%	22%	25%	16%	13%
Current status/ importance placed on hygiene specialists in companies and society and measures to improve them	9%	12%	11%	38%	4%	13%	8%	3%	8%	22%	10%	9%	11%
The appointment of an industrial physician be required by law	5%	-	11%	13%	4%	13%	5%	2%	4%	22%	15%	6%	7%
Introduction of mandatory health checks	17%	24%	16%	38%	16%	29%	26%	18%	-	11%	30%	20%	18%
How to control the safety and health risks of older employees	17%	24%	14%	19%	20%	17%	23%	13%	18%	22%	25%	16%	17%
Measures to promote cooperation between community and occupational health management	11%	18%	5%	13%	20%	25%	8%	9%	14%	11%	25%	16%	13%
How safety and health laws and regulations should be for self-employed people such as cloud workers and freelancers	24%	24%	16%	31%	32%	8%	31%	19%	20%	33%	10%	34%	28%
Stronger definition on health and safety laws for mobile workers	21%	29%	8%	38%	24%	33%	31%	17%	12%	33%	50%	27%	25%
Greater focus on employee mental health	40%	47%	27%	56%	36%	54%	49%	55%	31%	33%	35%	48%	44%
Greater importance of Health and Safety Law in civil cases	12%	12%	11%	31%	12%	8%	23%	7%	10%	22%	30%	20%	14%
Other	4%	-	3%	-	4%	-	5%	2%	6%	-	5%	2%	4%
Don't know	21%	-	16%	6%	12%	17%	5%	17%	18%	-	5%	13%	11%
<b>Q14. How much importance do you place on health and safety in management?</b>													
Base	424	7	17	6	8	5	13	31	35	2	4	54	193
Very important	67%	71%	65%	83%	63%	100%	69%	87%	60%	50%	100%	89%	74%
Moderately important	25%	29%	35%	17%	25%	-	23%	10%	26%	50%	-	11%	23%
Neutral	6%	-	-	-	13%	-	8%	3%	9%	-	-	-	3%
Not very important	1%	-	-	-	-	-	-	-	6%	-	-	-	1%
Not at all important	1%	-	-	-	-	-	-	-	-	-	-	-	-
<b>Q15. You say that health and safety in management is important. Why do you say this? Please select up to three reasons.</b>													
Base	390	7	17	6	7	5	12	30	30	2	4	54	186
I do not want the emotional toll of being responsible for an accident	52%	57%	65%	50%	71%	60%	33%	50%	63%	50%	50%	46%	51%
An accident could lead to paying a large compensation	24%	43%	41%	33%	29%	-	25%	23%	43%	50%	50%	15%	24%
An accident could negatively affect company morale	36%	14%	18%	17%	43%	80%	42%	53%	30%	100%	25%	48%	41%
An accident could negatively affect my company's reputation	47%	57%	47%	50%	43%	20%	83%	70%	57%	50%	50%	46%	53%
It is the company policy	27%	29%	12%	50%	14%	20%	17%	27%	17%	-	25%	31%	26%
The company has experienced a major industrial accident before	3%	14%	-	17%	-	-	-	-	3%	-	-	6%	4%
I could be punished for violating the law	27%	29%	41%	33%	43%	40%	50%	23%	23%	-	25%	9%	27%
An accident could lead to more absenteeism from employees	17%	43%	24%	-	14%	20%	33%	10%	7%	50%	25%	20%	20%
Other	14%	14%	18%	17%	14%	-	-	10%	3%	-	25%	22%	13%
<b>Q16. In your approach to health and safety, which of the following measures, if any, are you currently taking? Please select up to three.</b>													
Base	127	4	3	2	-	3	5	18	10	2	4	15	58
We have dedicated senior managers in charge of health and safety	67%	75%	67%	50%	-	67%	80%	72%	60%	50%	100%	67%	72%
We offer generous remuneration for health and safety specialists	13%	-	33%	50%	-	67%	-	-	20%	-	50%	7%	10%
A department in charge of safety and health has been set up, and one or more staff members are assigned for every 100 employees	22%	50%	33%	50%	-	-	20%	28%	10%	50%	-	13%	28%
We respect the authority of the health and safety specialists within the business	66%	50%	33%	100%	-	67%	60%	50%	50%	50%	100%	67%	64%
The staff assigned to the department in charge of safety and health is reassigned to a central department (personnel department or business management department) of the company or appointed as an officer	33%	50%	67%	50%	-	67%	20%	17%	50%	50%	25%	47%	36%
Other	5%	25%	-	-	-	-	-	-	-	-	25%	7%	7%
None of these	5%	-	-	-	-	-	20%	11%	-	-	-	-	3%
<b>Q17. In your approach to health and safety, which of the following measures, if any, are you currently taking? Please select up to three.</b>													
Base	263	3	14	4	7	2	7	12	20	-	-	39	128
We have a health and safety committee	16%	33%	21%	50%	-	-	14%	17%	20%	-	-	10%	20%
An independent health and safety expert is invited to participate in the health and safety committee.	11%	-	29%	25%	-	-	-	17%	15%	-	-	13%	12%
A health and safety assistant has been appointed within the company	28%	33%	36%	50%	43%	100%	14%	50%	25%	-	-	26%	32%
We have commissioned an external health and safety consultant to conduct a workplace assessment and issue guidance	22%	67%	36%	-	29%	-	-	42%	20%	-	-	23%	26%
Other	10%	-	14%	25%	14%	-	-	-	10%	-	-	13%	11%
None of these	37%	33%	14%	25%	14%	-	71%	8%	40%	-	-	33%	30%
<b>Q18. You say that health and safety in management is not important. Why do you say this? Please select up to 3 reasons.</b>													
Base	10	-	-	-	-	-	-	-	2	-	-	-	1
We believe accidents are inevitable in the workplace and cannot be prevented	30%	-	-	-	-	-	-	-	50%	-	-	-	100%
In the event of an accident, it is unlikely we will be required to pay compensation	30%	-	-	-	-	-	-	-	50%	-	-	-	100%
In the event of an accident, it is unlikely to negatively affect staff morale	10%	-	-	-	-	-	-	-	-	-	-	-	-
In the event of an accident, our reputation will not suffer	20%	-	-	-	-	-	-	-	-	-	-	-	-
Staff do not place importance on health and safety	-	-	-	-	-	-	-	-	-	-	-	-	-
Because the current top management does not place much importance to it	-	-	-	-	-	-	-	-	-	-	-	-	-
Because previous top management did not place much importance to it	-	-	-	-	-	-	-	-	-	-	-	-	-
Because the company has hardly / never experienced an accident	40%	-	-	-	-	-	-	-	50%	-	-	-	100%
Even if it is punished by law, it will not be a big disadvantage	20%	-	-	-	-	-	-	-	-	-	-	-	-
Other	20%	-	-	-	-	-	-	-	50%	-	-	-	-



**Kindai University Osaka**  
**Health & Safety survey**  
 Fieldwork Dates: 9th - 18th December 2020



Total	Familiar x Involvement	
	Familiar + Indirectly involved	Familiar + Not involved

**Q1. Please answer your gender**

Base	1005	194	39
Male	62%	71%	64%
Female	38%	29%	36%

**Q2. Age**

Base	1005	194	39
20s	3%	4%	8%
30s	18%	14%	10%
40s	24%	25%	13%
50s	33%	34%	23%
60s and over	22%	24%	46%

**Q3. Nation**

Base	1005	194	39
England	85%	85%	85%
Wales	3%	3%	5%
Scotland	10%	12%	8%
Northern Ireland	2%	1%	3%

**Q4. Please answer your occupation.**

Base	1005	194	39
Managers, executives and senior officials	57%	58%	41%
Professional occupations	20%	16%	36%
Associate professional and technical occupations	6%	5%	-
Administrative and secretarial occupations	3%	5%	-
Skilled trades occupations	3%	4%	8%
Caring, leisure and other service occupations	3%	2%	-
Sales and customer service occupations	2%	4%	8%
Process, plant and machine operatives	0%	1%	-
Elementary occupations	0%	1%	-
Other	5%	4%	8%
Not Applicable - I don't work	0%	-	-

**Q5. Please tell us about your position within the company you operate or belong to.**

Base	1005	194	39
Company/Organization Manager	25%	16%	13%
Executive/Board Member	17%	13%	8%
Middle Manager (in HRM division)	6%	6%	3%
Middle Manager (in other than HRM division)	27%	38%	28%
Professionals (other than safety and health related)	11%	16%	21%
Professionals (safety and health related)	4%	2%	-
Subordinate (in HRM division)	0%	1%	-
Subordinate (in other than HRM division)	1%	2%	-
Others	6%	5%	13%
Not applicable - I don't have any management responsibility.	3%	3%	15%

**Q6. Please tell us about the type of business of the company you operate or belong to. If there are multiple applicable industries, please answer the one that you are mainly involved in.**

Base	1005	194	39
Agriculture	1%	1%	3%
Forestry	0%	1%	-
Fisheries	0%	-	-
Mining	0%	1%	-
Construction industry	6%	4%	8%
Manufacturing industry	10%	12%	13%
Electricity, gas, heat supply, water supply	1%	2%	-
Information and communication industry	6%	4%	8%
Transportation industry	3%	3%	3%
Wholesale / Retail	6%	8%	3%
Finance / Insurance	3%	3%	5%
Real estate industry	4%	3%	5%
Restaurant / accommodation business	4%	5%	13%
Medical and welfare	7%	4%	3%
Education / learning support	14%	14%	15%
Service industry (not classified elsewhere)	7%	7%	10%
National institutions (those not classified elsewhere)	2%	2%	-
Local government (not classified elsewhere)	4%	5%	-
Others	21%	23%	13%

**Q7. Are you involved in work related to the health and of the company to which you operate or belong to?**

Base	1005	194	39
Directly involved	51%	-	-
Indirectly involved	36%	100%	-
Not involved	14%	-	100%

**Q8. Please tell us about the number of employees of the company you operate or belong to.**

Base	1005	194	39
0 people	-	-	-
1-9 people	29%	11%	36%
10-49 people	11%	10%	10%
50-99 people	10%	11%	5%
100-499 people	19%	21%	13%
500-999 people	6%	7%	10%
Over 1,000 people	25%	39%	26%
Don't know	-	-	-

**Q9. How much, if anything do you know about UK Health and Safety Law (the law, regulations, code of conduct, guidelines, etc)?**

Base	1005	194	39
A great deal	14%	14%	-
A fair amount	47%	86%	100%
Only a little	30%	-	-
Hardly anything	8%	-	-
Nothing at all	2%	-	-

**Q10. When thinking about health and safety regulation in the UK, which of the following most closely resembles your view?**

Base	610	194	39
Too strict	11%	9%	8%
Generally appropriate	79%	81%	79%
Not strict enough	5%	4%	3%
It varies across different areas	6%	5%	10%

**Q11. Still thinking about health and safety regulation in the UK, which of the following most closely resembles your view?**

Base	610	194	39
Regulation is easy to understand and implement	23%	21%	13%
There are some aspects that are difficult to understand, but it can be implemented with guidance	72%	73%	79%
It is too complicated to understand and implement	5%	6%	8%

**Q12. Since the current Health and Safety at Work Act (HSWA) was enacted in 1974, the number of fatal-injuries in the UK has decreased by more than 80%. What, if anything, do you see as the main reason(s) for this? Please select all that apply**

Base	1005	194	39
Comprehensive hazard prevention standards (i.e. standards that clearly indicate what should be done and what should not be done)	48%	45%	62%
Implementation of a health and safety management system (e.g. the appointment of a health and safety manager)	51%	54%	54%
Better cooperation and coordination when multiple employers carry out construction at the same location	20%	20%	23%
Stronger voluntary efforts of staff and management towards health and safety within the workplace	31%	37%	28%
Allowing businesses sufficient freedoms to enact their own changes	10%	9%	10%
Easy to understand the relationship between laws, regulations, code of conduct, and guidance	17%	18%	15%



**Kindai University Osaka**  
**Health & Safety survey**  
 Fieldwork Dates: 9th - 18th December 2020



	Total	Familiar x Involvement	
		Familiar + Indirectly involved	Familiar + Not involved
So-called three-step approach (First, take essential safety measures, second, take engineering measures for risks that cannot be dealt with by that, and third, take human measures such as education for the remaining risks to prevent industrial accidents) is employed	30%	33%	36%
Employer liability	54%	64%	64%
Potential fines for employees who breach regulations	32%	35%	44%
Measures to prevent occupational accidents (providing safe products, providing information on risks, etc.) are passed throughout the supply chain	52%	60%	56%
There is an evaluation and registration system for machinery and chemical substances treated in workplace	26%	29%	38%
Realistic and well-balanced regulations	28%	25%	36%
Under this law, the HSE (Health and Safety Executive) has implemented appropriate health and safety guidance based on high expertise	43%	46%	38%
Regular inspections and guidance from independent health and safety inspectors	37%	39%	46%
Under this law, a safety representative has supported the health and safety management of employers	23%	25%	23%
Fines being issued to employers in the past	29%	29%	31%
Potential fines for senior management if regulations are violated	38%	44%	38%
Other	4%	5%	3%
Don't know	8%	2%	10%

**Q13. When thinking about potential changes to the current Health and Safety at Work Act, which of the following issues, if any, do you think need greater focus?**

	Base		
A stronger definition of 'welfare' in the legal context	1005	194	39
A stronger definition of 'reasonable practicable' in the legal context	23%	27%	18%
Legal nature of the Code of Conduct (ACOP)	27%	30%	21%
A stronger definition of legal obligations imposed on stakeholders (e.g. managers, designers, manufacturers)	11%	12%	18%
Stronger definition of risk for those working in spaces where harmful substances are handled	23%	26%	18%
Stronger assessment of risks posed to workers dealing with chemical substances	14%	13%	21%
Stronger management of risks posed to workers dealing with chemical substances (e.g. controlling exposure)	19%	20%	26%
Measures to raise management awareness of health and safety regardless of business scale	19%	19%	28%
Current status/ importance placed on safety specialists in companies and society and measures to improve them	28%	29%	36%
Current status/ importance placed on hygiene specialists in companies and society and measures to improve them	11%	13%	10%
The appointment of an industrial physician be required by law	9%	8%	5%
Introduction of mandatory health checks	5%	5%	10%
How to control the safety and health risks of older employees	17%	16%	31%
Measures to promote cooperation between community and occupational health management	17%	15%	26%
How safety and health laws and regulations should be for self-employed people such as cloud workers and freelancers	11%	15%	15%
Stronger definition on health and safety laws for mobile workers	24%	21%	33%
Greater focus on employee mental health	21%	20%	23%
Greater importance of Health and Safety Law in civil cases	40%	41%	56%
Other	12%	13%	8%
Don't know	4%	7%	3%
	21%	12%	15%

**Q14. How much importance do you place on health and safety in management?**

	Base		
Very important	424	58	8
Moderately important	67%	78%	88%
Neutral	25%	19%	-
Not very important	6%	3%	-
Not at all important	1%	-	13%
	1%	-	-

**Q15. You say that health and safety in management is important. Why do you say this? Please select up to three reasons.**

	Base		
I do not want the emotional toll of being responsible for an accident	390	56	7
An accident could lead to paying a large compensation	52%	54%	57%
An accident could negatively affect company morale	24%	23%	-
An accident could negatively affect my company's reputation	36%	38%	14%
It is the company policy	47%	54%	29%
The company has experienced a major industrial accident before	27%	30%	29%
I could be punished for violating the law	3%	4%	14%
An accident could lead to more absenteeism from employees	27%	18%	29%
Other	17%	11%	14%
	14%	18%	14%

**Q16. In your approach to health and safety, which of the following measures, if any, are you currently taking? Please select up to three.**

	Base		
We have dedicated senior managers in charge of health and safety	127	35	3
We offer generous remuneration for health and safety specialists	67%	71%	33%
A department in charge of safety and health has been set up, and one or more staff members are assigned for every 100 employees	13%	20%	33%
We respect the authority of the health and safety specialists within the business	22%	17%	33%
The staff assigned to the department in charge of safety and health is reassigned to a central department (personnel department or business management department) of the company or appointed as an officer	66%	60%	100%
Other	33%	34%	33%
None of these	5%	3%	-
	5%	6%	-

**Q17. In your approach to health and safety, which of the following measures, if any, are you currently taking? Please select up to three.**

	Base		
We have a health and safety committee	263	21	4
An independent health and safety expert is invited to participate in the health and safety committee.	16%	29%	-
A health and safety assistant has been appointed within the company	11%	14%	-
We have commissioned an external health and safety consultant to conduct a workplace assessment and issue guidance	28%	33%	-
Other	22%	24%	25%
None of these	10%	14%	-
	37%	14%	75%

**Q18. You say that health and safety in management is not important. Why do you say this? Please select up to 3 reasons.**

	Base		
We believe accidents are inevitable in the workplace and cannot be prevented	10	-	1
In the event of an accident, it is unlikely we will be required to pay compensation	30%	-	-
In the event of an accident, it is unlikely to negatively affect staff morale	30%	-	-
In the event of an accident, our reputation will not suffer	10%	-	-
Staff do not place importance on health and safety	20%	-	-
Because the current top management does not place much importance to it	-	-	-
Because previous top management did not place much importance to it	-	-	-
Because the company has hardly / never experienced an accident	40%	-	-
Even if it is punished by law, it will not be a big disadvantage	20%	-	-
Other	20%	-	100%

Cell Contents (C)



## 二. 行政官・元行政官向け調査の結果



御中

前略

平素よりお世話になっております。

ご多用中、誠に恐縮ですが、

厚生労働科学研究費補助金（労働安全衛生総合研究事業）：労働安全衛生法の改正に向けた法学的視点からの調査研究プロジェクト（主任研究者：三柴 丈典）

より、行政官：監督官・技官（OB）の方に、調査へのご協力をお願い申し上げます。匿名で結構です。

この研究プロジェクトは、

- ①技術系の色彩の強かった労働安全衛生法を事務系にも理解してもらえるようにする、
- ②同法に詳しい学者や専門家を増やす、

という 2 点を目的として、同法に関する本格的な体系書を発刊すると共に、多職種の専門家が集う学術団体の創設を図っており、別紙のメンバーにより構成されています。

体系書は、学術的な体系性と共に、現場の臨場感が伝わるようなものとする予定です。

1 年目の研究成果は、厚生労働科学研究データベース（国立保健医療科学院）のほか、

<http://www2.gol.com/users/t-mishiba/con6-4.html>

に掲載されています。

本調査へのご回答は、回答者の所属を示さず、本研究プロジェクトの報告書及び発刊予定の著書で活用させて頂く予定です。

なお、ご回答は、以下のウェブサイトまたはメールアドレスでも受け付けさせて頂いております。

回答用ウェブサイト：

回答用メールアドレス：

## 1、労働安全衛生法の

### 第 章 第 節

にある条文と、それに紐付く重要な省令の条文（別紙資料をご参照下さい）が適用された実際の例のうち、その条文の特徴をよく示すものをご教示下さい。守秘義務を侵さない範囲に情報を抽象化して頂いて結構です。また、全ての枠を埋めて頂く必要はありません。

なお、紐付き省令の条文については、別紙資料に掲載された条文以外を採り上げて頂いて

も結構です。

【本法関係】

労働安全衛生法第（ ）条の適用例

労働安全衛生法第（ ）条の適用例

労働安全衛生法第（ ）条の適用例

労働安全衛生法第（ ）条の適用例

【省令関係】

主に労働安全衛生法第（ ）条に紐付く  
（ ）規則第（ ）条の適用例

主に労働安全衛生法第（ ）条に紐付く  
（ ）規則第（ ）条の適用例



主に労働安全衛生法第（ ）条に紐付く  
（ ）規則第（ ）条の適用例

主に労働安全衛生法第（ ）条に紐付く  
（ ）規則第（ ）条の適用例

2, 1 に掲げた章・節以外に属する条文と、それに紐付く重要な省令の条文（別紙資料をご参照下さい）が適用された実際の例で、その条文の性格をよく示すものをご教示下さい。守秘義務を侵さない範囲に情報を抽象化して頂いて結構です。また、全ての枠を埋めて頂く必要はありません。

なお、紐付き省令の条文については、別紙資料に掲載された条文以外を採り上げて頂いても結構です。

**【本法関係】**

労働安全衛生法第（        ）条の適用例

労働安全衛生法第（ ）条の適用例

労働安全衛生法第（ ）条の適用例

【省令関係】

主に労働安全衛生法第（ ）条に紐付く  
（ ）規則第（ ）条の適用例

主に労働安全衛生法第（ ）条に紐付く  
（ ）規則第（ ）条の適用例

主に労働安全衛生法第（ ）条に紐付く  
（ ）規則第（ ）条の適用例

主に労働安全衛生法第（ ）条に紐付く  
（ ）規則第（ ）条の適用例

3、現在の労働安全衛生法について、専門家が本格的に検討すべきと思われる課題を、次のうちから3つ選んで下さい。

- ① 条文に出てくる「危険を及ぼすおそれ」とは何か、どのように判断すべきか
- ② 条文に出てくる「常時」とは何か、どのように判断すべきか
- ③ 条文に出てくる「事業者」とは誰か、どのように判断すべきか
- ④ 建築工事での労災を防止するため、その設計者、発注者などに法的義務を課すべきか、課すとすればどのような義務を課すべきか
- ⑤ 機械作業での労災を防止するため、製造業者・加工業者などの譲渡提供者に法的義務を課すべきか、課すとすればどのような義務を課すべきか
- ⑥ 化学物質による被害を防止するため、その物質の製造業者・加工業者などの譲渡提供者に法的義務を課すべきか、課すとすればどのような義務を課すべきか
- ⑦ 事業規模を問わず、経営層の安全衛生の意識と知識を高めるための方策
- ⑧ 中小企業の安全衛生管理を向上させる方策
- ⑨ 安全の専門家の企業や社会での地位の現状と向上策
- ⑩ 衛生の専門家の企業や社会での地位の現状と向上策
- ⑪ アメリカのインダストリアル・ハイジニストのような高レベルの化学物質管理の専門家向けに国家資格を創設すべきか
- ⑫ ハザード（物質そのものの危険有害性）より、リスク（それが実際に被害を引き起こす可能性や生じ得る被害の重さ、管理方法の有無など）を重視した、柔軟性やメリハリのある化学物質管理規制のあり方～危険有害物質への労働者のばく露を有効に管理するための規制方法を含む～
- ⑬ 化学物質の製造業者・加工業者などの譲渡提供者に提供させるべき情報の範囲と提供先
- ⑭ 増加する高齢者に多い安全衛生上のリスクを考慮した規制のあり方
- ⑮ 複数ある健康診断制度の再編
- ⑯ 地域と職域の健康管理の連携を進めるための方策
- ⑰ クラウドワーカーや委託就労型労働者など、多様な就業、契約形態のもとにある者への安全衛生法規制のあり方
- ⑱ 派遣労働者に対して安全衛生法の実施を果たす責任は派遣元・派遣先のどちらが負うか（派遣法第45条で既に規定されたものを除く）
- ⑲ 労災をめぐる民事裁判での安全衛生法の意義（法的効力）
- ⑳ 産業ロボットへの接触に関する規制のあり方

( ) ( ) ( )

その他（概ね 100 字以内でお願い致します）

4, 現行の労働安全衛生法について、改正が必要と思われる内容をお示し下さい。

(1)

(2)

(3)

5, 職種をご教示下さい（○で囲って下さい）。

監督官     ・     技官

元監督官   ・   元技官

6, 今後、この研究プロジェクトにご協力頂ける場合、以下の情報をお知らせ下さい。

お名前

ご連絡先

---









労働安全衛生法第	61条2項		20条16
労働安全衛生法第	61		41
労働安全衛生法第	61		41
労働安全衛生法第	61	クレーン則	221 (司法)
労働安全衛生法第	61	クレーン則	221 (司法)
労働安全衛生法第	65		28
労働安全衛生法第	66		29
労働安全衛生法第	66		44
労働安全衛生法第	66		44
労働安全衛生法第	66		44
労働安全衛生法第	66		48
労働安全衛生法第	66の4		51の2
労働安全衛生法第	66の4		52の2
労働安全衛生法第	77		20～24
労働安全衛生法第	88		90
労働安全衛生法第	100		96
労働安全衛生法第	100		97 (司法)
労働安全衛生法第	100		97の1項
労働安全衛生法第	100		98
<b>設問2</b>			
<b>【本法関係】</b>	<b>条</b>		<b>条</b>
労働安全衛生法第	10,11,12,13		
労働安全衛生法第	12		
労働安全衛生法第	12		
労働安全衛生法第	12		
労働安全衛生法第	13		
労働安全衛生法第	13		
労働安全衛生法第	14		
労働安全衛生法第	17		
労働安全衛生法第	18		
労働安全衛生法第	18		
労働安全衛生法第	17,18		
労働安全衛生法第	29		
労働安全衛生法第	30		
労働安全衛生法第	40		
労働安全衛生法第	41条の2	ボイラー則	38,40
労働安全衛生法第	57		
労働安全衛生法第	61		
労働安全衛生法第	65		
労働安全衛生法第	78		
労働安全衛生法第	79		
労働安全衛生法第	101		
労働安全衛生法第	101		
労働安全衛生法第	103		
労働安全衛生法第	103		38
労働安全衛生法第	103		51
労働安全衛生法第	120		
労働安全衛生法第	122		
労働安全衛生法第	122		
労働安全衛生法第	122		
<b>2-【省令関係】</b>			
労働安全衛生法第	12		7
労働安全衛生法第	12		4,7
労働安全衛生法第	13		13
労働安全衛生法第	13		5,13
労働安全衛生法第	14		18
労働安全衛生法第	14		18
労働安全衛生法第	14		133
労働安全衛生法第	14		566
労働安全衛生法第	18		9
労働安全衛生法第	18		23
労働安全衛生法第	19		23
労働安全衛生法第	20		28
労働安全衛生法第	20		123
労働安全衛生法第	20		349
労働安全衛生法第	20		534
労働安全衛生法第	21		266
労働安全衛生法第	22		579,593
労働安全衛生法第	22	高圧作業安全衛生	37
労働安全衛生法第	45	クレーン等安全規則	34
労働安全衛生法第	45		151の21
労働安全衛生法第	45		151の21
労働安全衛生法第	57		2
労働安全衛生法第	57の3		34の2の7
労働安全衛生法第	61		20条16

労働安全衛生法第	66 8の3		52の7の3
労働安全衛生法第	66 8の3		52の7の3
労働安全衛生法第	66 8の3		52の7の3
労働安全衛生法第	100		95条の6
労働安全衛生法第	100		96
労働安全衛生法第	101		98
労働安全衛生法第	103		23
労働安全衛生法第	103		135の2

設問3	
項目	数
1	32
2	51
3	5
4	12
5	11
6	8
7	16
8	15
9	3
10	3
11	2
12	12
13	3
14	21
15	9
16	2
17	12
18	4
19	5
20	2
設問5	
監督官	49
技官	15
元監督官	12
元技官	2
不明	3

81

## 質問 1 労働安全衛生法

### 【1-本法関係】

#### ●労働安全衛生法第(2)条、第(20)条ほか

重層請負関係にある建設工事現場の末端労働者に関する労働安全衛生法第 20 条の措置義務に関し、労働者派遣法第 45 条のみなし規定適用により、(本来は認められていない)実質的な作業指示を行う請負関係上位事業者を本条の措置義務者として立件した。同様の事例は少なからずある。

このことは、労働者派遣法第 4 条第 1 項、労働安全衛生法第 29 条、同第 29 条の 2 等の立法趣旨とは異なる次元で、重層請負関係にある中小建設工事(実態として請負関係の末端における実質的労務供給=派遣はなくなっていない)の安全衛生措置義務の所在を逆説的に明確にする効果を発揮しているともいえる。

労働者派遣法施行以前は、捜査において社会経済的に責任を負うべきと考えられる上位請負事業者の措置義務を認定するための論理構成とその証拠化の困難、あるいは、末端事業者の故意認定の困難が立ちはだかつていたが、実質的に労働者派遣法第 45 条は立件にあたっての貴重なツールとなっている。(000236 元監督官)

#### ●労働安全衛生法第(5)条(安全管理)の適用例

建設工事現場において、共同企業体が発注者から業務を請け負ったため、当該共同企業体から、労働安全衛生法第 5 条に基づき、共同企業体の代表者選任届が提出された。条文の特徴として、具体的な選出方法は、安全衛生規則(第一条)に定められており、同規則の規定に基づき、選任届は労働基準監督署長を経由して提出された。(00147 監督官)

#### ●労働安全衛生法第(6)条の適用例

労働災害防止 5 か年計画に基づいて、安全衛生対策の重点を置いているので、沖縄局版の労働災害防止計画の内容を、違反としての適用ではなく指導レベルで適用している。(00107 監督官)

#### ●労働安全衛生法第(11)条(安全管理)、安衛則第(6)条(安全管理者の巡視及び権限の付与)の適用例

九州地方の大手電機工事業の事業場において、安全巡視者(安全管理者との表記はない)の安全巡視について、タブレットにより計画から現場における帳票作成、写真撮影、巡視結果データ保管、印刷等までを 1 つのデバイスで完結できるようにした結果、情報の共有によるよりの確な指導等が可能となるとともに、活用が大幅に広がったという取り組みを行っている。条文では、安全管理者が、安全俊氏で把握した法令違反等明確な危険のおそれに対し、その場で危険防止措置を講じるようなことが想定されていると思われるが、法令を上回るような安全確保措置を含めて安全管理を組織的に取り組んでいるような状況においては、安全巡視で得られた情報の電子的な処理、それによる情報共有、組織的な判断・対応が必要になっていると思われる。(00222 元監督官・元技官)

#### ●労働安全衛生法第(11, 12, 12 の 2, 13)条の適用例

安衛令で定める業種、規模の事業場に対して、安衛則で定める資格要件を満たす安全管理者等を選任していない場合、適用する。(00196 不明)

#### ●労働安全衛生法第(12)条の適用例

同一県内に本社及び複数の支店を有する事業者において、常時 50 名以上の労働者を使用する事業場(支店)で専属の衛生管理者を選任しておらず、本社専属の衛生管理者が複数支店の衛生関係業務を行っていたことから、支店における衛生管理者の選任について指導を行ったもの。(000155 不明)

●労働安全衛生法第(14)条の適用例

作業受任者の未選任、作業主任者の氏名職務の未周知に係る法違反(00167 監督官)

●労働安全衛生法第(14)条の適用例

法 14 条作業主任者 政令 6 条対象となる作業を列挙。

法 14 条作業主任者 省令(安衛則)18 条作業主任者の職務氏名の周知。(00177 監督官)

●労働安全衛生法第(17,18)条の適用例

金属製品製造業で常時使用する労働者が 50 人以上の事業場について、安全委員会や衛生委員会を開催していなかったため、安衛法 17 条第 1 項と安衛法第 18 条第 1 項の法違反を指摘した。

安衛法第 19 条には、安全衛生委員会が設置可能である旨の条文があるが、安全委員会と衛生委員会の両委員会の設置が義務付けられている事業場に対し、実務上、安衛法第 19 条による違反ではなく、安衛法第 17 条違反と安衛法 18 条違反のそれぞれの法違反を指摘している。(00035 監督官)

●労働安全衛生法第(17, 18, 19)条の適用例

安衛令で定める業種と規模の事業場において、本条で定める安全委員会等を設けていない場合、適用する。(00196 不明)

●労働安全衛生法第(20)条の適用例

洗濯したタオルを乾燥後にほぐす機械(シェイカー)にて目詰まりが発生したため、解消作業に行ったが戻ってこないで同僚が見に行ったところ、同シェイカー内で倒れていたという事例

・単独作業であったことから現認者がおらず、労働安全衛生規則第 107 条に定める「機械の給油、検査または調整の作業」の特定ができず、法違反を特定できないという意見がある一方、実態として機械(シェイカー)が動いている時に機械を止めていれば災害は発生しなかったのだから、法違反を認めるべきとの意見があった。(00170 不明)

●労働安全衛生法第(20)条の適用例※2(のちの労働安全衛生法第(27)条)の適用例で参照)

工場内で木工作業を行うに当たり、労働者が使用する木材加工用丸のこ盤に歯の接触予防装置を設けなかった。(00072 監督官)

●労働安全衛生法第(20)条の適用例

・動力気亜紀の歯車の覆いがない。・安全装置の不備。・掃除等の場合の運転停止・プレス安全装置の未設置。(00167 監督官)

●労働安全衛生法第(20)条の適用例

機会等の中には足場が含まれているため、建設現場の監督指導が多い監督署としては、建設業で適用することが多い。(00107 監督官)

●労働安全衛生法第(20)条の適用例(クレーン則第 69 条及び 70 条の疑い)

平成 7 年当時、東京都文京区の建設工事現場で移動式クレーンを使用して作業中、安全装置を無効にしてオーバーウエイト状態のまま、クレーン作業を行った結果、クレーンが前のめりになり、ジブが折損、清掃事務所の建物を一部損傷、労働者が被災する災害が発生した。



特定機械の災害であることから、行政機関として「災害調査」と共に司法事案として検察庁(区検)に書類を送致。(000283 元技官)

●労働安全衛生法第(20、第21)条の適用例

倉庫内で移動はしごを使用して、高さ約3メートルの場所に置かれた段ボール箱を下そうとした際に、移動はしごから墜落した事例

- ・単独作業であったことから、状況を勘案し、移動はしごから墜落したと判断したもの
- ・単独作業であったことから、被災者がどの高さから墜落したのか不明。このため、労働安全衛生規則第518条、第519条の適用は見送ったもの
- ・また、労働安全衛生規則第526条についても、移動はしごを使用して昇降していることから、同則違反ではないとする意見がある一方、当該移動はしごは短く、段ボール箱のおかれた場所の高さに届いていないなど、不安全な状態で使用していたのだから、同則違反を認めるべき、との意見があった。(00170 不明)

主に労働安全衛生法第(21)条に紐付く労働安全衛生)規則第(518)条の適用例

輸送運搬機械製造会社で、同社所属の労働者3名が、工場建屋内壁面へ電源コンセントを増設する作業を行っていたところ、うち1名が地上から高さ約3メートルの梁上からコンクリート床面に墜落し、死亡した。同社責任者は、電源コンセント増設作業を行わせるにあたり、作業場所は高さが2メートル以上で、足場を組み立てる等の方法により、作業床を設けることが容易であったのに、これを設けず、もって労働者が墜落するおそれのある場所に係る危険を防止するために必要な措置を講じなかった。(0097 監督官)

●労働安全衛生法第(21)条の適用例

平屋建て倉庫のスレート屋根塗替え作業中、スレートを踏み抜き、倉庫床へ墜落した事例

- ・労働安全衛生規則第524条違反を認めたもの

行政解釈(昭和43.6.14安発第100号)において、「スレート、毛板等脆弱な材料で吹かれた屋根であっても、当該材料の下に野地板、間隔が30センチメートル以下の母屋等が設けられており、労働者が踏み抜きによる危害を受ける恐れがない場合には本条を適用しないこと」とされているが、現場には野地板が張られておらず母屋の間隔も30センチメートルを超えていた。

いずれにせよ、労働者が屋根を踏み抜いて墜落により被災した場合は、特段の墜落防止対策を事業者が講じなければ法違反が成立すると思料するが、「母屋の間隔が30センチメートル」という基準は通達にしか認められないほか、「墜落する恐れ」を構成要件とすることは根拠がぜい弱であることは否めないのではないか。

(00170 不明)

●労働安全衛生法第(21)条の適用例

墜落防止災害で多い災害の1つであることから、建設現場や工場内など墜落の恐れがあり、手すりのない箇所での適用が多い。(00107 監督官)

●労働安全衛生法第(22)条の適用例

局排の未設置。呼吸用保護具の未着用。(00167 監督官)

●労働安全衛生法第(22)条の適用例 有機則第24条

昭和 52 年当時、東京都三鷹市にあったメッキ工場で、個別指導による立ち入りで有機溶剤の危険・有害性などの掲示が汚損され、且つ機械設備の陰に隠れている状況が現認されたことから、文書により「掲示物の整備」と「掲示場所の位置変更」を行政指導した事案。(000283 技官)

#### ●労働安全衛生法第(23)条の適用例

労働安全衛生規則第 53 条の適用により、健康管理手帳の交付を労働者がされたとき、管理に困るということが想定されます。携帯電話のアプリ等に連結させた方が、より身近に管理・保存できそうです。(00025 監督官)

#### ●労働安全衛生法第(23)条の適用例 事務所則第 (21) 条

平成 2 年当時、東京都目黒区内で労働者数が 50 名を超える製造業の事業場への立ち入りで、休養室が男女別に設置されていないことから、改善されるまでの間は、打ち合わせ室の一部を転用するなどの緊急措置を指導し、しっかりとした出入口、及び室内の区画をレイアウトし、男女別に休養室を整備し、鍵を設けて管理されるなどについて、文書交付により行政指導を実施。(000283 技官)

#### ●労働安全衛生法第(27)条の適用例

なお、同条で定める事業者が講ずべき措置は、労働安全衛生法第 27 条により、構成労働省令へ委任されている。上記事例※1(労働安全衛生法 100 条第 1 項)※2(労働安全衛生法 20 条)では、労働安全衛生規則第 123 条に委任される。(00072 監督官)

#### ●労働安全衛生法第(29)条の適用例

RC 造マンションの新築工事現場において、足場を使用する一次下請事業者の労働者が安衛則第 567 条に基づく足場の点検を行っておらず、加えて、当該点検の未実施について元方事業者による指導が一切行われていなかったことから、下請事業者等(関係請負人及び関係請負人の労働者)が法令の規定に違反しないよう必要な指導を行うよう元方事業者に対して指導したもの。(000155 不明)

#### ●労働安全衛生法第(29)条の適用例

建設現場で下請け事業場が違反していた時。(00005 監督官)

#### ●労働安全衛生法第(29)条の適用例

事案 1 木造家屋新築工事現場において、作業者が建屋 2 階の開口部から墜落した事案

##### 1 事案概要

木造 2 階兼住宅新築工事において、被災者(1 次下書事業者の労働者)は、窓から建材を受け渡すため建材を持った状態で窓に近づいたところ、ユニットバス設置用のピットから 1 階床に墜落した。墜落高さ 3m。被災者は墜落制止用器具を着用していたが、現場には墜落制止用器具の取付設備はなかった。

##### 2 適用の要旨

ユニットバス設置用ピット周囲には囲い、手すり、覆い等が設けられておらず、また現場の状況から、それらの設置が困難である事情も認められなかったため、当該 1 次下請事業者に対し、安衛法 21 条第 2 項(安衛則第 519 条第 1 項)違反を是正勧告した。また元請負事業者は、当該 1 次下請事業者に対し安衛法に違反しないよう必要な指導を行っていなかったため、元請事業者に対し安衛法第 29 条第 1 項違反を是正勧告した。(00122 監督官)

#### ●労働安全衛生法第(29)条の適用例



元方事業者に対して、関係請負人と関係請負人の労働者が労働安全衛生法とその関係法令について違反が認められた場合、必要な指導を行わなかったとして適用する。(00196 不明)

#### ●労働安全衛生法第(29)条の適用例

土木建設用鋼材のリースを行っている会社の構内で、土木建設用鋼材の洗浄や整備を請け負っている会社の作業員がアーク溶接を行っていたが、当該作業員に対しアーク溶接特別教育を受講させていなかった。

下請会社に対して、安衛法 59 条 3 項違反を指摘した後、元請であるリース会社には安衛法 29 条第 1 項違反を指摘した。

事業者間に請負関係が成立していた場合で、かつ下請業者で安衛法違反が成立した場合、建設業に限らずあらゆる業種の事業者について安衛法 29 条違反が成立するといった特徴がある。(00035 監督官)

#### ●労働安全衛生法第(29)条の適用例

関係請負人及び関係請負人の労働者に安衛法違反が認められたとき、元請(建設業)に対して指導。(00163 監督官)

#### ●労働安全衛生法第(29)条の適用例

労働安全衛生法第 30 条(特定元方事業者の講ずべき措置)及び、第 31 条(注文者の講ずべき措置)においては、紐づけられる安全衛生規則があるため、下請に違反があった場合に、該当する安全衛生規則の特別規則(第四編)の違反を元請に対して指摘するが、これらに該当しない違反(特化則、有機則等)を下請に指摘した際には、より専門知識の必要な分野として元請への援助が必要不可欠となるにもかかわらず、条文として罰則のない安全衛生法第 29 条を適用させるしかなかった事例。

メンテナンス工場の現場において、タッチアップのため、事前の有機溶剤等を使用した払拭作業を下請業者が行っているにもかかわらず、知識不足から、有害性の認識が無く、作業主任者、呼吸用保護具未着用等、法令に基づく措置の未実施が見受けられたもの。当該事業者には、該当する違反を指摘したものの、管理すべき元請から必要な指導がないものとして、労働安全衛生法第 29 条を適用させたもの。(00040 監督官)

#### ●労働安全衛生法第(29)条の適用例

建設現場において、元方事業者が、関係請負人に対し安全衛生法の規定に違反しないように必要な指導を行っていなかったもの(例：安衛法第 61 条の就業制限違反、安衛則第 519 条の墜落防止措置違反等)。若しくは、元方事業者が、関係請負人に対し安全衛生法に違反していると認めていたにもかかわらず、是正のための必要な指導を行っていなかったもの。

(00212 監督官)

#### ●労働安全衛生法第(29)条第 1 項の適用例

これは広く行われておりますが、建設現場において下請けに違反があると、元方事業者に対し、殆ど必ず本項違反を是正勧告しております。

ただ、是正勧告の文面において、「…の命令の規定に違反しないよう必要な指導を“十分”行っていないこと」という、ちょっと表現を和らげることがあります。

これは、通常、元方事業者が各種指導を既に沢山行っているからです。

本条には罰則がありませんのでそのように和らげてもよいかなという感覚があります。(番号なし監督官)

#### ●労働安全衛生法第(29)条の適用例

建設現場において、下請けの事業場の労働者が労働安全衛生法上必要な安全措置を講じておらず、労働安全衛

生法違反が発生しているにもかかわらず、是正のため必要な指示又は法令に違反しないよう必要な指導を元請け業者が行っておらず、当該条文に抵触したものの。(00089 監督官)

●労働安全衛生法第(29)条の適用例

関係請負人に法違反が認められたところ、元方事業者(元請)において関係請負人が違反しないよう必要な指導を行っていなかったことで、1項を適用。(00173 技官)

●労働安全衛生法第(29)条第1項)の適用例

建物の解体工事において、関係請負人(1次下請け)が小型車両系建設機械を使ってフレコンバックを吊り上げる作業中、荷を掛ける作業をしていた労働者が荷と建設機械に手を挟まれて負傷した。車両系建設機械を主な用途以外の用途に使用し、また、その運転者は小型車両系建設機械の運転のための特別教育を修了していなかったが、元請事業者が、関係請負人に対して、法令に違反しないよう必要な指導を行っていなかったことが判明したので、元請事業者に対して、本条違反とした。(00180 監督官)

●労働安全衛生法第(29)条の適用例

法31条の適用がない業種で、下請業者又はその労働者に違反が認められた場合に元請に対し是正を勧告する。(00162 監督官)

●労働安全衛生法第(29)条の適用例

元方事業者が関係請負人及びその労働者が法令違反しないよう必要な指導義務を違反していると認めるときは是正のため必要な指示義務を求めているが、「必要な」指導、「必要な」指示が具体的にどこまでが不明確である。

また、この条文には罰則規定がない。元方事業者として努力義務でよいのかと感ずるところもあるが、止むを得ないところではあろう。

請負人は、実質は元方事業者の指示のもとに工事や業務を行うが、司法処分するときには請負人が安衛法違反の主体であり、元方事業者に捜査の範囲として及ぶのは、共犯として立件するときくらいである。必要な指導、必要な指示を明確化し、罰則付きにすることは如何であろう。

(00076 監督官)

●労働安全衛生法第(29)条の適用例

建設工事において、下請業者が無資格就業により労災事故を発生させたため、元方事業者に対し、下請業者に対する必要な指導を行っていなかったとして是正勧告を行なった。(00121 監督官)

●労働安全衛生法第(29)条の適用例

製造業種 元方事業者

構内請負労働者がピットから墜落し、ピット内容物に埋もれて死亡。

請負事業者533違反について、元方違反が成立。(00058 監督官)

●労働安全衛生法第(29)条の適用例

・元方事業者として、関係請負人及び関係請負人の労働者が当該仕事に関し、この法律又はこれに基づく命令の規定に違反しないよう必要な指導を行っていない。

・建設現場において、下請事業者に法違反が認められた時に、元請事業者に対して適用。

(00027 監督官)

### ●労働安全衛生法第(29)条の適用例

関係請負人の労働者に安衛法違反が認められ、元方事業者が必要な指導を行っていないことが認められたため、同条に基づき違反を指摘した。(00174 監督官)

### ●労働安全衛生法第(30)条の適用例

建設業、造船業に課される元方規制について、造船業の仕事も請け負っている製造業の事業場内で作業する下請事業者の労働災害が発生した場合、その事業場内で作業する下請事業者の労働者にかかるものであれば、作業を行っていた物が総專業にかかるものであっても、本来の重たる事業による判断となることから監督指導において、注意を要する場合があります。また、死亡労働災害の場合は、検察や警察に対して法の適用の説明をすることが難しいことが多々あります。(00204 監督官)

### ●労働安全衛生法第(31)条の適用例

建設現場での足場、開口部からの墜落防止対策が不十分なことにより、事業者へ違反を適用するとともに、併せて注文者へも違反を適用することが多い。(00107 監督官)

### ●労働安全衛生法第(33)条の適用例

機械貸与契約(いわゆるオペ付きリース)により、多くの建築工事現場で移動式クレーン作業等が行われているところであるが、本条による措置が不十分であるため、災害・事故が発生している状況もみられる。措置が不十分な例としては、機械貸与を受ける者がリース業者に対して移動式クレーン作業計画を示すなどにより、法定事項を通知していないことなどである。(00074 監督官)

### ●安衛法 37 クレーン則 3①

#### 【クレーン則 3①違反の既遂時期はいつか】

ある法人が工場に設置するある設備の製品搬送機械としてつり上げ荷重が7tのテルハを設置する場合において、当該設備設置工事全体の請負業者(元請)からクレーンの設置を請け負った一次下請Xとさらにその下請(二次下請)Yがいずれも当該クレーンの製造許可を持っていなかった事案です。

本件は、監督指導時にすでに当該テルハの走行レールがすでに工場内に設置されていたほか、レールに乗せられる予定の巻上機も現場に準備されている状態(要するにもうほとんど完成という状態)で、安衛法違反として刑事事件も視野に入れるべき状態でした。

クレーン則 3①では、クレーンを製造しようとする者は、その製造しようとするクレーンについてあらかじめ、…労働局長の許可を受けなければならない」と規定されています。

是正勧告のレベルであれば、「許可もないのにほぼ完成の状態まで作っていた」わけですから、「あらかじめ…許可を受けていない」ことは明らかですから法違反を指摘して何ら問題はないといえます。

しかし刑事事件とするならば、その犯罪発生時期(既遂時期)は、犯罪事実の一部であり、処罰の対象となる行為を特定する上で非常に重要です。

しかし、「製造しようとする」とはいつの時点をいうのかが何も言われていないのです。

もし、同条文が「許可のない者は製造してはならない」と規定されているならば、「製造」とは「原材料・(粗製品)を加工して製品にすること」(新明解国語辞典)をいうことから「製造許可なくクレーンを作った(完成させた)とき」を既遂時期ととらえて差し支えないとおもわれます(ですので設例の場合ですと、既遂には達していないという判断になるかと思いますが)。

しかし、クレーン則 3①は「クレーンを製造しようとする者は、…あらかじめ」ですから、既遂時期はもっと前になってきます(クレーン則 3②の規定から製造許可の制度が、実際に製造されたクレーンの安全を担保する制

度というだけでなく、当該クレーンを製造する製造者が安全な機械を製造できる者であるかどうかをも担保する制度といえるので妥当だと思われます）。

「製造しようとする」とは、①「頭の中でクレーンを作ろうと思いついたとき」でしょうか、②「クレーンの構造計算を行ったとき」でしょうか、③「設計図を作成したとき」でしょうか、④「製造にかかる契約を締結したとき」でしょうか、⑤「製造に必要な部材の発注をおこなったとき」でしょうか、⑥「部品の組み立て・加工がはじまったとき」でしょうか。

本職は、犯罪として処罰を求めるには、いわゆる「無許可製造」による危険が現実には生じうる状態になった必要があると考え、現実には製造に取り掛かった⑥の時点をもって製造許可がなければ既遂に達するものと判断しているが、異動のため結末を見ず、その正しかったのかは不明です。（00071 監督官）

#### ●労働安全衛生法第(40)条の適用例

安衛令第 12 条で定める特定機械について、安衛法第 37 条の製造許可を受けずに製造した特定機械、安衛法第 88 条の設置届等を提出せずに安衛法第 38 条の製造時検査等を受けなかった特定機械（設置届を提出時には製造時検査等の実施は確認する）、検査証の交付を受けたが性能検査等の未実施により検査証の有効期限が切れた状態で使用している特定機械等について、適用する。（00196 監督官）

#### ●労働安全衛生法第(40)条の適用例

町工場で、労働局等の落成検査を受けずにつり上げ荷重が 10 トンのクレーンを設置し、クレーンのフックに 2.8 トンの表示をして、あたかも検査証が必要ないクレーンと偽装して使用していたものについて、検査証を受けていない特定機械を使用していたとして書類送検した。（000157 監督官または元監督官）

#### ●労働安全衛生法第(40)条の適用例

製造業の事業場に於て、荷物用エレベーター（積載荷重 3.0t）をその検査証の有効期間を更新（性能検査を未受検）せずに使用を継続していたことが判明し適用した。（00130 監督官・技官）

#### ●労働安全衛生法第(44)条の適用例

私の所属先では、法別表第 3 に掲げられる「ゴム、ゴム化合物又は合成樹脂を練るロール機の急停止装置のうち電氣的制動方式のもの」について、「登録個別検定機関」として厚生労働大臣の登録を受け、個別検定を行っている。（00228 元技官）

#### ●労働安全衛生法第(44)の 2)条の適用例

私の所属先では、法別表第 4 に掲げるもののうち、12 品目について「登録型式検定機関」として厚生労働大臣の登録を受け、型式検定を行っている。主要な検定品目としては、防爆構造電気機械器具、防じんマスク、防じんマスク、保護帽、電動ファン付呼吸用保護具がある。（00228 元技官）

#### ●労働安全衛生法第(44)条の 2 第 7 項の適用例

木材加工業の事業場に設置されているテーブル丸のこ盤に、歯の接触予防装置が設けられていましたが、可動部が壊れ、事業場の代表者がお手製で直して使っていましたが、型式検定は受けていませんでした。「木材加工用丸のこ盤並びにその反ばつ予防装置及び歯の接触予防装置の構造規格」に適合しているかどうかは不明であったので、型式検定を受けていないという違反も成立していると思われました。しかし、おそらく合格しないと思われる型式検定を受けろというもおかしい気がしたので、その場の判断で、「型式検定合格標章が附されていないものを使用している」として本項の是正勧告をしました。（番号なし 監督官）

#### ●労働安全衛生法第（45 条）の適用例



プレス機械等災害の発生した機械について、特定自主検査（以下「特自検」という）を実施していない機械が認められるが、特自検が実施されていないほとんどの機械は定期自主検査（以下「自主検査」という）も実施されていない。プレス機械等の特自検が必要な機械については本来自主検査を実施したうえで特自検を行っていない場合に特自検の違反が成立しうるものと考えられる。行政的には特自検違反を措置することで両方の違反を回避できるため、労働安全衛生法第 45 条第 1 項、同法同条第 2 項の条文を併記して指摘を行うか、特自検のみの違反にて指摘し、是正を求めている。（00170 不明）

●労働安全衛生法第(45)条の適用例

フォークリフトの年次点検(特定自主検査)が未実施であったため、本条文を適用した。（00130 監督官・技官）

●労働安全衛生法第(53条の3)の適用例

登録性能検査機関となろうとする者は、労働安全衛生法第 53 条の 3 に基づき、登録を受けなければならないため、同条に基づく申請がなされる。条文の特徴として、同条は、労働安全衛生法第 46 条等の一部読み替えによる準用の規定となっているため、並行して第 46 条等を確認する必要がある。加えて第 46 条は、「第 38 条第 1 項の規定による登録(中略)厚生労働令で定めるところにより」と規定されており、さらに平行して第 38 条の条文や対象となる厚生労働令(登録省令)を確認しないとイケないため、内容を理解するのが非常に難しい構成となっている。加えて厚生労働省が登録省令を指していることは、容易にわかるものではないため、全体として、自発的に申請手続について理解するのは困難であると思料する。

(00147 監督官)

●労働安全衛生法第(57)条の3の適用例

「職場における化学物質等のあり方に関する検討会」資料  
特別規則対象外物質による典型的な災害事例

1 ラベル表示・SDS 交付対象物質のリスクアセスメントが未実施であること等による災害事例法 57 条の 3

発生月	概要	程度
平成 29 年 5 月	1-ブロモプロパンを含む溶剤で治具や製品の洗浄作業をしていたところ、体調不良を訴え、急性薬物中毒と診断されたもの。少量生産部門であったため、防毒マスクの着用や局所排気装置の設置、リスクアセスメントが実施されていなかった。	休業 14 日 (1 名)
平成 29 年 8 月	飼料の燻蒸作業を行ったところ発生したリン化水素によって気分が悪くなったもの。リスクアセスメントは実施されていなかった。また、作業員は防毒マスクをしておらず、換気も不十分であった。	休業 10 日 (1 名)
平成 30 年 8 月	住宅新築工事現場において、床断熱材の隙間を埋めるため、ポリメチレンポリフェニルポリイソシアネート、メチレンビス(4,1-フェニレン) = ジイソシアネートを含有する断熱材をスプレーにて吹き付ける作業を行っていたところ、中毒を起こしたもの。リスクアセスメントは未実施であり、特段のばく露防止対策は講じていなかった。	休業 1 日 (1 名)

(00224 元技官)

●労働安全衛生法第(59)条の適用例

法 59 条第 1 項に基づく雇入れ時の安全衛生教育を実施していなかったため、適格に実施するようにアドバイスをしました。(00286 技官)

●労働安全衛生法第(59)条の安衛法則(36)条(3)項の適用例

特別教育の必要な作業を列挙。(00177 監督官)

●安衛法 (59) ③ 安衛則 (36) クレーン則(21、同 222)

【つり上げ荷重 0.5t 未満のクレーンの運転・玉掛にかかる特別教育は必要か】

安衛則 36 の 15 号ではつり上げ荷重 5t 未満のクレーンの運転について、同 19 号ではつり上げ荷重 1t 未満のクレーンの玉掛業務についてはそれぞれ特別教育が必要とされているが、同条を根拠とした特別教育規定はありません(安衛則 39 で除外されている)。

一方、クレーン則 21 および 222 でも同様の規定がされており、クレーン則に基づく特別教育規定が制定されています。クレーン則をクレーンに関する安衛則の特別法と考えるならばクレーン則が適用される場合、一般法である安衛則の規定は適用にならず、クレーン則に基づく特別教育を行っていけば適法といえるでしょう。

しかし、クレーン則 2 では、つり上げ荷重 0.5t 未満のクレーンについてはクレーン則の適用を除外すると定めています。

そうすると、つり上げ荷重 0.5t 未満のクレーンはクレーンでありながらクレーン則の適用がなくなるが、クレーンであることには違いはなく、安衛則 36 では、規則の適用除外はなく、同条に基づく特別教育を実施する必要があると判断されるところ、同条に基づく特別教育規定がないため特別教育を行いたくありません。

多くの技官・監督官で、「クレーンに関しては特別法であるクレーン則が一般法である安衛則に優先し、その優先するクレーン則でつり上げ荷重 0.5t 未満のクレーンは法の適用が除外されているのだから特別教育は不要」という意見を聞きますが、果たして正しいのでしょうか。

本職は、クレーン則は、「つり上げ荷重 0.5t 未満のクレーンはクレーンではない」と言っているわけではなく、クレーン則を適用しないと述べているのであり、当該機械もクレーンに他ならないのであれば、特別法の適用がない場合には一般法が適用になるとの原則により、現時点においては安衛則に基づく特別教育が必要でありそのための特別教育規定の整備が必要と考えます(当然、0.5t 未満のクレーンについて規制の必要がないから安衛則上、特別教育を不要とする改正もありうるでしょう)。(00071 監督官)

●労働安全衛生法第(61)条の適用例

電気機械器具の製造を行う事業場において、フォークリフト運転特別教育を修了しているのみで、フォークリフト運転技能講習を修了していない労働者に最大荷重が 1 トン以上のフォークリフトの運転業務を行わせていたことから、有資格者に当該業務を行わせるよう指導した。(00155 不明)

●労働安全衛生法第(61)条の適用例

事業者 A の代表取締役 B は、法令で定める資格を有しないにも関わらず、最大荷重 1 トン以上のフォークリフトを運転した。

労働安全衛生法第 59 条第 3 項の特別教育については、事業者が労働者に対して必要な教育を行うことを義務付けているのに対し、労働安全衛生法第 61 条第 1 項において「資格を有する者でなければ、当該業務に就かせてはならない。」と規定しており、事業主、法人の役員等であっても資格が必要となっている。また、同条第 2 項においては「前項の規定により当該業務につくことができる者以外の者は、当該業務に就かせてはならない。」と規定しており、事業者以外にも義務を課している。

このことにより、労働安全衛生規則第36条で定める業務（特別教育を必要とする業務）と労働安全衛生法施行令第20条（就業制限に係る業務）に大きな差があり、就業制限に係る業務の危険・有害性が高いことを象徴している。（00206 監督官）

#### ●労働安全衛生法第(61条)第(2)項の適用例

産業労働の場において、第61条第1項(令第20条)により定められた就業制限業務について、次の身分の無資格者が就労していたため、第61条第2項の違反と取り扱われ、労働基準監督署から関係者に指導等が行われた。

(1) 労働者

(2) 非労働者

ア 事業の代表者

イ 代表権のない法人の役員(常務取締役等)

ウ 個人事業主(一人親方)

(実務家から見た論点1)第1項以外の物の意義

就業制限業務の無資格就労に関して、監督行政機関は事業者に対して第61条第1項を適用して指導、行政処分等を行うケースが圧倒的に多いが、中には事業者の指揮監督権が及びに状況下で無資格就労が行われるケースもある。労働者が事業者の知らないところで無資格就労している場合、無資格就労の主体が一人親方である場合などである。このような場合には第61条第2項の規制を適用して処理することとなるので、同項の規定は重要な意義をもつと考える。

(同論点2)第1項の禁止は事業主にも向けられているか

第61条第1項は「事業者は、・・・(略)・・・、当該業務に就かせてはならない。」ろあり、「～させてはならない」類型の禁止規定である。この禁止の対象が労働者のみではなく、事業主自身にも及ぶのかどうかについて、及ぶとする説、及ばないとする説とに解釈が分かれている。事業主自身が制限業務に無資格就労した行為の擬律として、及ばないと解した場合は、第1項の違反に比べて法定刑の軽い第2項で処断するしかない。及ぶと解釈した場合は事業主自身の違反であるので問題なく第1項違反として処理できる。略式ではあるが、起訴例においても第1項か第2項か、適用の判断が割れている。(00268 元監督官)

#### ●労働安全衛生法第(61)条の適用例

法61条2項は、法定の就業制限業務について何人も無資格での就労をしないよう禁止しており、事業主も本条の適用を受けるところ、事業主自ら建設工事現場などで就業制限業務に従事している際には、その資格取得状況をよく注意する必要がある。(00074 監督官)

#### ●労働安全衛生法第(61)条の適用例

無資格運転(免許、技能講習)。(00167 監督官)

#### ●労働安全衛生法第(61)条の(2)項の適用例

(関連：労働安全衛生法施工令第20条、労働安全衛生規則第41条、規則別表第3)

期待重量3tのクレーン使用のドラグ・ショベルをクレーン仕様に切り替えず、技能講習を数量していない労働者が、ドラグ・ショベルを用いた堀削作業に従事していたもの又はクレーン仕様に切り替え、つり上げ荷重2.5tの移動式クレーンとして使用する場合に、技能講習を修了していない労働者が発電機を吊り上げてトラックの荷台に移動させる作業に従事していたもの。(00007 監督官)

#### ●労働安全衛生法第(61)条の安衛法政令(20)条の適用例

終業制限業務を列挙。安衛則(省令)41条は、日常的に参照することが少ない。(00177 監督官)

●労働安全衛生法第(65)条の(2) (作業環境測定の結果の評価等)、第(66)条の(5) (健康診断実施後の措置)、特化則(36)条の(5) (特定有機溶剤混合物に係る測定等)、第(41)条の(2) (特定有機溶剤混合物に係る健康診断)、粉じん則第(26)条の(3) 評価の結果に基づく措置 (他にじん肺法等の関係条文あり)の適用例

東北地方の大手ガラス製造業系列企業の事業場においては、特定の特別有機溶剤及び特定粉じん作業について、作業環境測定評価結果第 1 管理区分、特殊健康診断・じん肺健康診断結果有所見者なし、呼吸用保護具着用等衛生管理に問題がないと評価しているが、長期的な健康障害に係り有害性あり、取扱量が多く移動の多い作業携帯であることから、個人ばく露測定を行い、産衛学科のガイドラインに基づく一定(6段階評価中3番目)の良評価等であったものについて、具体的な改善措置を取っている。条文では、作業環境測定(評価)、特殊健康診断等の結果等が悪かった場合の措置が定められ、その中には、個人ばく露測定に係る措置は明記されていないが、がん、じん肺等の長期的な健康影響のリスクを下げる観点から、ここまで行われているものと思われる。

※上記2例は、中央労働災害防止協会編集・発行「第79回全国産業安全衛生大会研究発表集(令和2年度)の発表原稿をもとに、本回答がまとめたものである。(00222 元監督官・元技官)

●労働安全衛生法第(66)条の10条の適用例

ストレスチェック制度

・心理的な負担の程度を把握するための検査(ストレスチェック)制度の法規則、実施事項、実施マニュアルの紐づけが複雑で理解困難である。

・平成27年12月義務化以降、5年経過し、簡易調査票の問診事項が同一であり、マンネリが生じているため実施結果の収集方法の見直し等が必要。(安易に受検する者も少なからずある状況)(00059 技官)

●労働安全衛生法第(75)条の(2)、第(75)条の(3)、第(75)条の(4)、第(75)条の(5)、第(75)条の(6)、第(75)条の(7)、第(75)条の(8)、第(83)条の(2)、第(83)条の(3)、第(85)条の(2)、第(85)条の(3)、作業環境測定法第20条、第21条、第22条、第23条、第24条、第25条、第26条、第32条の2適用例  
公益財団法人安全衛生技術試験協会(以下「試験協会」という。)は、ボイラー技士、クレーン・デリック運転士、衛生管理者等免許試験、作業環境測定士試験、労働安全・労働衛生コンサルタント試験の実施に関する事業及び作業環境測定士及び労働安全・労働衛生コンサルタント試験の登録に関する事業を、国に代わって行う唯一の指定試験期間・指定登録期間としての指定それに伴う役員の選任、試験事務規定及び事業計画の認可を受け、また、免許試験員の選任の届出など行い、安全衛生を推進する人材、なかでも危険有害な業務や安全衛生のための指導的立場に立つ業務に携わる人材を質及び量ともに確保していくことにより、我が国の安全衛生水準の向上を図るため、公正、安定的かつ効率的な試験事業の実施に努めている。(00222 元監督官・元技官)

●労働安全衛生法第(76)、(77)条の適用例

三重労働局登録教習期間。(00259 監督官)

●労働安全衛生法第(88)条の適用例

・足場の設置届について、当該工事の開始の日の30日前までに届け出ていない。

・高さ31メートル以上の建物の計画届を開始の14日前までに届け出ていない。

(00027 監督官)

●労働安全衛生法第(100)条第(1)項の適用例※1 (労働安全衛生法第(27)条)の適用例で参照)

(関連：労働安全衛生規則第97条第1項)

4日以上休業を要する労働災害が発生したのに、遅滞なく労働者私傷病報告書を提出しなかったもの。



(00072 監督官)

●労働安全衛生法第(101)条の適用例

行政機関から送付された通達等については、職場のイントラネットに掲載するなどして周知を図っている。

(00228 元技官)

●労働安全衛生法第(103)条の適用例

「登録個別検定機関」「登録型式検定機関」として、総務部が中心となって、関係書類の整備、保管を行っている。(00228 元技官)

●労働安全衛生法第(115)条の適用例

天然ガスの採掘を行っている事業場において、爆発事故により労働者が被災した際、災害発生の原因として安全管理上の問題があった。

労働安全衛生法に照らすと法違反があったが、当該事業場は鉱山に指定されていたため、法第 115 条により安衛法が適用されず、鉱山保安法が適用されることとなり、経済産業省の産業保安監督部が鉱山保安法違反容疑で捜査・送致を行った。

なお、労働者死傷病報告は所轄労働基準監督署に提出された。(00082 監督官)

●回答可能な事案なし。

なお、【省令関係】で回答の安衛法 59 条 3 項「特別教育」違反、同 61 条 1 項・2 項「就業制限」違反については、構成要件の一部が省令で規定されているものであるから、「本法関係」にも該当し得ると考える。(00057 監督官)

【1-省令関係】

●主に労働安全衛生法第(14)条に紐づく(労働安全衛生)規制第(18)条の適用例

労働安全衛生法第 14 条では作業主任者に労働者の指揮その他の省令で定める事項を行わせなければならないと定めているが、これは作業主任者の職務であると考えられ、労働安全衛生規則第 18 条の作業主任者の氏名等の周知義務は、労働安全衛生法第 14 条では何ら触れていないため、労働安全衛生規則第 18 条は、労働安全衛生法第 14 条と関連はあるが、根拠条文とまでは言えないと考えられる。(00186 監督官)

●主に労働安全衛生法第(14)条に紐づく(石綿障害予防)規則第(19)条の適用例

石綿を含有する配管の保温材の除去作業を行うにあたって、有資格者の中から石綿作業主任者が選任されていなかったことから、資格を有する者の中から当該作業主任者を選任するよう指導したものの。

なお、当該現場では、平成 18 年 4 月 1 日以降に特定化学物質作業主任者技能講習を修了した者が石綿作業主任者として選任されていた。(000155 不明)

●主に労働安全衛生法第(14)条に紐づく(安衛)規則第(129)条の適用例

木材加工用機械(丸のこ,帯のこ等)で手をケガした件につき、本来機会を使う立場にない労働者が被災しており、作業を直接指揮するはずの作業主任者が選任されていない状況で労働者が勝手に使用していた為に被災したことから、同法を適用した。(機械は 5 台以上所有していた)(00130 監督官・技官)

●主に労働安全衛生法第(20)条に紐づく(労働安全衛生)規制第(17)条の適用例

生コンクリート製造会社工場内にて、ミキサーの運転を停止させ、被災者ほか 1 名をしてミキサー内の清掃

作業を行わせるにあたり、ミキサー内に設けられた羽根が回転し労働者に危険を及ぼすおそれがあったのに、ミキサーの起動装置であるプラント動力盤に鍵をかけ、あるいは同動力盤にもうけられている表示板を裏返しして注意喚起させる等の措置を講じないまま、同清掃作業を行わせ、もって機械、器具その他の設備による危険防止のための必要な措置を講じなかった。(00097 監督官)

●主に労働安全衛生法第(20)条に紐づく(労働安全衛生)規制第(27)条の適用例

(関連：労働安全衛生法第 42 条、法別表第 2 第 10 号、木材加工用丸のこ盤等構造企画第 30 条)携帯用丸のこ刃部の衝動覆いの木片により、固定していたため、ばねが利かなくなり、木片を外しても移動覆いが切断に必要な部分以外の部分を覆うことが出来ず、構造企画を満たしていないものを使用していたもの。(00007 監督官)

●主に労働安全衛生法第(20)条に紐づく(労働安全衛生)規制第(27)条に紐づく(労働安全衛生)規制第(137)条の適用例

工場内の木工作業を行うに当たり、労働者が使用する木材加工用丸のこ盤に歯の接触予防措置を設けなかった。(00072 監督官)

●主に労働安全衛生法第(20)条に紐づく(労働安全衛生)規則第(27・28)条の適用例

つり上げ荷重が 1 トンのクレーンについて、クレーン構造規格で定めるフックの外れ止め装置を確認したところ、クレーン A の外れ止め装置はバネが壊れて無効になっており、クレーン B の外れ止め装置は取れてなくなっていた。このとき、クレーン A について労働安全衛生規則第 28 条の違反、クレーン B について労働安全衛生規則第 27 条の違反を指摘した。(00082 監督官)

●主に労働安全衛生法第(20)条第(1)号、同法第(27)条第 1 項に紐づく(労働安全衛生)規制第(131)条第 2 項、第 3 項の適用例

(事案概要)ある工場において、労働者に動力プレス機械(いわゆる安全プレス)※を使用して金具の穴あけ加工作業を行わせるに当たり、同プレス機械には両手捜査式起動スイッチが取り付けられていた。同プレス機械には操作の切替えキースイッチが設けられていて、同スイッチをフット操作に切り替えが場合には、両手捜査式起動スイッチが作動せず労働者の安全が確保出来なくなるので、同プレス機械の停止性能に応じた性能を有する光線式の安全装置を労働者に使用させる等の必要な措置を講じなければならないのに、これを行わずに同作業を行わせ、機械、器具その他の設備による危険を防止するため必要な措置を講じられていなかった。

※労働安全衛生規則第 131 条第 1 項ただし書において「スライド又は刃物による危険を防止するための機構を有するプレス等については、この限りではない」としている。本件プレスは、本来この「スライドによる危険防止するための機構を有するプレス」として製造されたいわゆる「安全プレス」であり、両手操作式起動スイッチを使用し、もしくは光線式安全装置が有効な状態で無いとスライドが作動しない構造となっていた。しかしながら、本件プレスは、災害発生日、両手捜査式起動スイッチを使用せずフットスイッチで起動させていたので光線式安全装置により身体の一部が危険限界内に入った場合にはプレス機械が停止しなければならないにもかかわらず、光線式安全装置が作動せずにスライドが動いていた。これは、本件プレスの電気回路を短絡させることにより、光線式安全装置が無効な状態でも、フットスイッチの操作でスライドを作動させることができるようにしていたものであった。(本件プレスは中古品であり、元々、誰が短絡させたかは特定できなかった)。よって、本件プレスは、「スライドによる危険防止するための機構を有するプレス」ということはできないものであった。

(2)運用した条文

労働安全衛生規則第 131 条第 1 項の措置に講じていない場合であっても、同第 2 項に規定する「作業の性質上、前項の規定によることが困難なとき」に該当すれば、「当該プレス等を用いて作業を行う労働者の安全を確保する

ため、安全装置を取り付け]れば、違法な状態とはならない。本件については、解釈例規にある多品種少量生産の場合、形状の複雑な材料を加工する場合等に該当するため、「作業の性質上、前項の規定によることが困難なとき」に該当し、両手操作式起動スイッチを備え、光線式安全装置を具備したものであったが、両手操作式起動スイッチは使用せず、さらに光線式安全装置の電気回路は短絡され、無効な状態となっており、労働者の安全を確保するための安全装置がない状態であった。

また、行政通達(昭和 53 年 2 月 10 日付け基発第 78 号)によると、同規則第 131 条第 2 項の「安全装置を取り付ける等必要な措置」には、①片手では専用の手工具が使用され、かつ、他方の手に対して囲い等が設けられていることや②専用の手工具が両手で保持され、材料の送給又は製品の取り出しが行われることが含まれるが、本件作業中には、これらに該当する安全装置は一切講じられていなかったため、安全装置を取り付ける等必要な措置が講じられていないことは明らかであった。よって労働安全衛生規則第 131 条第 2 項及び第 3 項を適用した。

### (3)競合する条文

安全プレスに関わる構造規格を具備しない動力プレス機械を使用したという点で、労働安全衛生規則第 27 条の適用も検討した。本件に関しては、動力プレス機械構造規格第 5 章に定める規格を具備しないことから、労働安全衛生規則第 131 条第 1 項但し書きの安全プレスに該当しなくなるが、同条第 2 項の措置を講じていれば、労働者の安全が確保されるため、同規則第 27 条違反については適用しなかった。(00063 監督官)

#### ●主に労働安全衛生法第(20)条に紐付く(安衛)規則第(28)条の適用例

- ・丸のこ盤の歯の接触予防装置が有効な状態で使用されるようそれらの点検及び整備を行っていないこと。
- ・プレスの光線式安全装置について、有効な状態で使用されるよう、それらの点検及び整備を行っていないこと。
- ・安全装置は設けられており、簡単な整備で有効に使用することができるが、現状では有効でない状態の時に適用する。

(00027 監督官)

#### ●主に労働安全衛生法第(20)条に紐づく(労働安全衛生)規制第(28)条の適用例

携帯用丸のこの刀部の移動覆いを木片により、羽部を覆わない状態で固定して使用し、安全装置を無効にしているのに点検、整備をせずに使用していたもの。(00007 監督官)

#### ●主に労働安全衛生法第(20)条に紐づく(労働安全衛生)規制第(28)条の適用例

- ・木造建築現場、木製製品製造の事業場などにおいて、携帯式丸のこ盤の刃の接触防止装置を、木片や紐で固定するなどして無効化している例が見られる。
- ・製造業などの事業場において、天井クレーンのフックの外れ止めが破損して無効となっている例が見られる。
- ・作業効率を優先し、機械のインターロックや光線式安全装置を無効化していることがある。

本条は、点検及び整備の義務を使用者に課しているものではあるが、機械の安全装置の点検・整備を行うという観点から希薄な事業場では、上記のような状況が認められることがある。(00074 監督官)

#### ●主に労働安全衛生法第(20)条に紐づく(労働安全衛生)規制第(101)条の適用例

労働安全衛生規則第 101 条第 1 項は、「機械の・・・プリー・・・等の労働者に危険を及ぼすおそれがある部分には、覆い、囲い、スリーブ、踏切橋等を設けなければならない」と規定されているため、金属製円柱製造のためのロールベンダーに身体の一部が巻き込まれる災害が発生した事案に対して、当該条文を適用させて違反を指摘したがロールベンダーについては、構造上、安全な覆いを設けることができないため、巻き込み側と反転する補助ロール、ロープ式緊急停止装置等を設置したことをもって、法令違反が是正されたものと判断



し、完結させている例。構成要件上、違反が是正されていなくも、指導を完結させている例。(00040 監督官)

●主に労働安全衛生法第(20)条に紐付く(安衛)規則第(101)条の適用例

- ・印刷機のプーリーで労働者に危険を及ぼすおそれのある箇所に囲いを設けていない。
- ・ベルトコンベヤーの端の回転軸、プーリーに囲いを設けていない。
- ・ボール盤の回転軸の止め具に埋頭型のものを使用していない。
- ・機械一般で、はさまれ・まきこまれのおそれのある構造で、労働者が通行する近づくなど危険を及ぼすおそれがある時に適用。(00027 監督官)

●主に労働安全衛生法第(20)条に紐付く(労働安全衛生)規則第(101)条の適用例

加工機械の動力伝導部に設けられたプーリー及びベルトに取り付けられた覆いが破損して外れたにもかかわらず、そのまま使用していたため、覆いを設けなかったとして是正勧告を行なった。(00121 監督官)

●主に労働安全衛生法第(20)条に紐づく(労働安全衛生)規制第(101)条の適用例

工場床面に対し、水平に高速回転するシャフトについて、囲い等が設置されていない状況下において、床面の雑巾がけをしていた労働者の作業服が巻き込まれ、その結果、両前腕を切断する労働災害が発生した。司法事件として立件装置した。災害後、シャフトに対し、囲いが完全に設置された。(00077 監督官)

●主に労働安全衛生法第(20)条に紐づく(労働安全衛生)規制第(101)条の適用例

一般機械器具製造業の工場において、機械の回転軸、歯車、プーリー、ベルト等について労働者に危険を及ぼすおそれがあったにもかかわらず、覆い等を設けていなかったもの。(00212 監督官)

●主に労働安全衛生法第(20)条に紐づく(労働安全衛生)規制第(107)条の適用例

事案Ⅱ 木材加工事業場において、木材加工用機械の清掃中に可動部に手指が接触した事案

1 事案概要

木材加工事業場において、被災者(所属労働者)は木材加工用機械を用いて木材を加工する作業を行っていた。作業中、木材加工用機械に木屑が溜まったため木屑を手で払い落そうとしたところ、誤って指が木材加工用機械の稼働部に接触し負傷した。

2 適用の要旨

木材加工機械の刃部以外の箇所の掃除を行う場合に、接触による危険があるにもかかわらず、その運転を停止しなかったため、安衛法第 20 条第 1 号(安衛則第 107 条第 1 項)違反を是正勧告した。(00122 監督官)

●主に労働安全衛生法第(20)条に紐づく(労働安全衛生)規制第(107)条の適用例

コンクリートミキサーの中で、ミキサー内の掃除を行っていた作業員 3 名がミキサーの起動スイッチを別の作業員が押したため、ミキサーに巻き込まれ死亡した。ミキサーの起動スイッチには、第三者が起動スイッチを操作することを防止するための表示板を取り付ける等の措置は講じられていなかった。(00024 監督官)

●主に労働安全衛生法第(20)条に紐づく(労働安全衛生)規制第(107)条の適用例

枯紙圧縮装置の中に入った労働者が、装置内の圧縮機を起動させる光線を身体で遮断したため、圧縮機が起動し、胴体を切断。死亡した。事故原因は圧縮装置の起動を停止する安全装置の故障によるもの。(圧縮装置内への入口の扉が「開」の状態では、圧縮装置の起動は停止状態となるものであった)(00024 監督官)

●主に労働安全衛生法第(20)条に紐付く(労働安全衛生)規則第(107)条の適用例

機械の修理作業を行う場合において、体がまきこまれるおそれがあったにもかかわらず、当該機械の運転を停止していなかったことが認められたため同法(同規則)に基づき違反を指摘した。(00174 監督官)

●主に安衛法(20)条に紐づく安衛則(107)条1項の適用例(34)

[違反条文内容] 掃除等の場合の運転停止等

[業種] ゴム製品製造業

[あらまし] 押出機の運転停止措置をとらずに掃除業務に従事させ、右腕を巻き込まれ切断【公表】

(00057 監督官)

●主に労働安全衛生法第(20)条に紐づく(労働安全衛生)規則第(107)条の適用例

紡糸機において、带状に束ねた繊維を引き延ばすロールに繊維が巻き付いたため、除去するためロールを稼働させたまま手工具を使い切断していたところ、繊維とロールの間に手工具が巻き取られ、ゴム手袋をはめていた左腕が巻き込まれた。

巻き付き措置(繊維の除去)は機械の調整の作業に該当、機械を運転したままの状態で行き付け措置を実施、1項を適用。(00173 技官)

●主に労働安全衛生法第(20)条に紐づく(安衛)規則第(107)条の適用例

印刷機の調整作業を行う際、当該機の運転を停止することなく作業を行ったため、指がはさまる労働災害が発生、本条文を適用した。(00130 監督官・技官)

●主に労働安全衛生法第(20)条に紐づく(労働安全衛生)規制第(107)条の適用例

食料品製造業において、労働者Aが混合機の修理作業を行うにあたり、危険を及ぼすおそれがあったにもかかわらず、事業者が機械の運転を停止せずに修理作業を行わせたことから、腕を巻き込まれて被災するという労働災害が発生した。

また、労働者Bが混合機の修理作業を行っていたが、事業者は、起動装置に表示板を取り付ける等、労働者B以外の労働者が当該機械を運転することを防止するための措置を講じていなかったことから、労働者Cが誤って混合機を起動させてしまい、労働者Bが混合機に巻き込まれ被災するという労働災害が発生した。(00212 監督官)

●主に労働安全衛生法第(20)条に紐づく(労働安全衛生)規則第(107)条第1項の適用例

被災者は、車両系建設機械の洗車を行うため、バケットとアームを使って左の履帯を浮かせ、金具を運転席のペダルにかませ、履帯を動かしたままの状態、運転席から離れて履帯の清掃を行っていた。履帯の内側に挟まっていたものを取り除こうとしたところ、手が履帯内側に挟まれて負傷した。機械の運転を停止せずに掃除を行っていたことが判明したので、本条違反とした。(00180 監督官)

●主に労働安全衛生法第(20)条に紐づく(安衛)規則第(107)条の適用例

印刷機の調整作業を行う際、当該機の運転を停止することなく作業を行ったため、指がはさまる労働災害が発生、本条文を適用した。(00130 監督官・技官)

●主に労働安全衛生法第(20)条に紐づく(労働安全衛生)規制第(107)条の適用例

機械を停止せずに掃除等を行い、機械に巻き込まれる(労働災害が多い)。(00005 監督官)

●主に労働安全衛生法第(20)条に紐づく(労働安全衛生)規則第(108)条第1項の適用例

被災者は、コンバインの清掃作業を、エンジンをかけた状態で行っていた。回転するわらカッターにわらが挟まっていたので、手で取ろうとしたところ、カッターに巻き込まれて負傷した。機械の運転を停止せずに機械の刃部の掃除を行っていたことが判明したので、本条違反とした。(00180 監督官)

●労働安全衛生法第(20)条に紐付く労働安全衛生規則第(108 条の 2)の適用例 (議論になった例)

冷蔵倉庫内で、自動で開いた自動ドア(冷凍庫のドアなので重く、動力も強い)の戸板の先に労働者がおり、近くにあった柱と戸板との間に挟まれて死亡しました。私は、その戸板の端をスクロール端として、第 108 条の 2 の適用があると考えましたが、「自動ドアは機械ではないのでは」という意見もあり、結局うやむやに…。当然自動ドアは機械だと思うので適用はあると思うのですが、一般基準(安衛則第 2 編第 1 章第 1 節)の適用が、機械安全の専門性のない監督官にとっては難しいのだなとおもったエピソードです。(番号なし監督官)

●主に労働安全衛生法第(20)条に紐づく(労働安全衛生)規制第(111)条の適用例

ボール盤を使用して金属に穴を開ける作業を行っていた労働者がドリルに着用していた軍手が巻き込まれ腕を切断。ショックにより死亡した。(00024 監督官)

●主に労働安全衛生法第(20)条に紐付く(安衛)規則第(123)条の適用例

木工機械を起因物とする労働災害に係る災害時指導に於て、刃の接触予防装置の未装備が判明したため適用した。(使用停止命令違反)(00130 監督官・技官)

●主に労働安全衛生法第(20)条に紐づく(労働安全衛生)規制第(123)条の適用例

・木製製品を製造する事業場において、「木材加工用丸のこ盤の刃の接触予防装置があると送剤の加工ができない。」として、取り外している例が見られる。

現状、本条の丸のこ盤の刃の接触防止装置としては、丸のこ刃の上部にプラスチック製のカバーを備え付けたものが主であり、建具など正確な寸法により木材加工の必要のある事業場においては、作業の邪魔であることを理由に取り外れてしまっている例が見られる。(00074 監督官)

●主に労働安全衛生法第(20)条に紐づく(労働安全衛生)規制第(131)条の適用例

フリクションプレスで金物の穴あけ作業を行っていたところ、同プレス機械には光線式安全装置が具備されていたが、光線式安全装置の機能を切り、足踏み操作(フートスイッチ)でプレスを操作していたところ、材料供給時にタイミングを誤ってフートスイッチを踏み込み、結果、プレス機械の金型間に右手指を挟まれ、被災した事案。同事業場では、本災害と近接した日時にも同様にプレス機械による挟まれ災害が発生していたことから、安衛法違反として送検したもの。(00077 監督官)

●主に労働安全衛生法第(20)条に紐づく(労働安全衛生)規制第(147)条の適用例

射出成型機等による危険の防止に関する条文であるが、コンクリートブロック成型機について適用し、送検したことがある。コンクリートブロック成型機が射出成型機等に含まれるか否かが、検察官の懸念するところであった。安衛法施工時の解釈通達に、射出成型機等の範囲を示したものがあり、およそ、動力によって加工用の装置を往復させて加圧、打抜きなどするものでプレスに該当しないもの全てが該当するとしている。あまりにも範囲を広げていて、事業者において本条文の適用は範囲を想定しにくくなっている。(00284 元監督官)

●主に労働安全衛生法第(20)条に紐付く労働安全衛生規則第(150 の 4)条の適用例

※産業用ロボットに接触することによる災害

産業用ロボットについて、ロボットに向かう通路には安全柵が設けられており、安全策を開けるとロボットが停止する構造であった。しかしながら、安全柵の周囲からもロボットの可動範囲に立ち入ることができた。

災害は、作業者がロボットのアーム部分と、積み重ねられたパレットの間に首を挟まれていた。発生状況は一人作業のため推定であるが、産業用ロボットが稼働中又は非常停止中に、作業者がロボットの可動範囲内に確認のため安全柵の周囲から立ち入ったところ、ロボットが稼働し、作業者に激突する災害が発生した。

↓

本作業は産業用ロボットが停止後の災害か稼働中の災害が判然としなかったため、産業用ロボットに柵または囲いを設ける等の措置が行われていなかったとして、安衛則第 150 条の 5 ではなく、第 150 条の 4 で措置した。

- ・「さく又は囲い」の範囲、性能、材質、表示等についてどこまで求められるか
- ・「運転の場合」について、稼働中に非常停止した場合は「運転の場合」含まれるか。
- ・柵は設けられていたが、開閉時にロボットの電源が遮断する構造である必要があるか。

(000157 監督官または元監督官)

●主に労働安全衛生法第(20)条に紐付く労働安全衛生規則第(151 条の 11)の適用例

(産業界のあらゆる状況に対応した具体的規制のありかたの難しさを示す事例)

いわゆるコンクリートミキサー車の運転手が配送先の待ち時間に運転席を降りた際に、当該車が逸走したことによる死亡労働災害を契機として同条違反で立件したものについて、「原動機を止め、かつ、停止の常態を保持するためのブレーキを確実にかける等～措置を講ずること」の前段措置が一般的に事実上困難であることにより不起訴となったもの。

コンクリートミキサー車や小型移動式クレーン搭載トラック等、付設する装置を当該自動車のエンジンで駆動するものは装置稼働中には原動機を停止することはできないので運転手は運転席を離れることはできない。このため、自動車運転手以外の助手等を配置しない限り、運転席から離れてミキサーのホッパー操作やクレーン操作ができないことになり、このようなものに複数配置している例は一般的にはない。ちなみに、道路交通法においては、運転者の遵守事項を定めた第 7 1 条第 5 号は「車両等を離れるときは、その原動機を止め、完全にブレーキをかける等当該車両等が停止の状態を保つため必要な措置を講ずること」となっており「かつ」の規定はない。(000236 元監督官)

●主に安衛法(20)条に紐づく安衛則(151 条の 13)の適用例(27)

[違反条文内容] 車両系荷役運搬機械等(不整地運搬車及び貨物自動車を除く。)の搭乗の制限

[業種] 畜産業

[あらまし] フォークリフトの乗車席以外に搭乗した労働者が墜落したもの【公表】

(000057 監督官)

●主に労働安全衛生法第(20)条に紐付く(労働安全衛生)規則第(151 条の 14)条の適用例

建設現場において、ドラグショベル(移動式クレーンモード搭載)で、クレーンモードを有効にしないまま、バケットを使用して荷のつり上げを行っており、用途外使用の禁止を定める当該条文に抵触したもの。(00089 監督官)

●主に安衛法(20)条に紐づく安衛則(151 条の 3 1 項)の適用例 (39)

[違反条文内容] 車両系荷役運搬機械等作業の際の作業計画



[業種] 機械（精密機械を除く）器具製造業

[あらまし] 【公表】フォークリフト作業を行うに当たり、あらかじめ作業計画を定めなかったもの(00057 監督官)

●主に安衛法(20)条に紐づく安衛則(151 条の 7 1 項)の適用例 (18)

[違反条文内容] 車両系荷役運搬機械等を用いる作業時の接触の防止

[業種] 印刷業

[あらまし] フォークリフトとの接触による死亡災害。接触防止のための立ち入り禁止措置。【公表】(00057 監督官)

●主に労働安全衛生法第(20)条に紐づく（労働安全衛生）規則第(151 条の 78) の適用例

被災者は、砂を運搬するコンベヤーのベルトが蛇行していたため、機械を運転させたまま、工具を使って調整作業を行っていたところ、手がコンベヤーのベルトと回転軸の間に巻き込まれて負傷した。被災者とコンベヤーをはさんで反対側にいた労働者が、被災者がコンベヤーに巻き込まれたことに気づいたが、非常停止装置が設置されておらず、機械の元電源を切って機械を停止させた。コンベヤーに非常停止装置を備えていないことが判明したので、本条違反とした。（00180 監督官）

●主に労働安全衛生法第(20)条に紐づく（労働安全衛生）規制第(151 の 3)条の適用例

フォークリフトの作業計画を作成していない。（00005 監督官）

●主に安衛法(20)条に紐づく安衛則(151 条の 731 項)の適用例 (19)

[違反条文内容] 荷台にあおりのある貨物自動車を走行させる場合の荷台への乗車制限等

[業種] その他の廃棄物処理業

[あらまし] 貨物自動車のあおりを閉じずに労働者を荷台に乗車させ、当該労働者が転落【公表】(00057 監督官)

●主に安衛法(20)条に紐づく安衛則(155 条 1 項)の適用例 (37)

[違反条文内容] 車両系建設機械作業の際の作業計画

[業種] その他の建設業－その他

[あらまし] 【公表】車両系建設機械を用いた作業に係る作業計画の未(00057 監督官)

●主に労働安全衛生法第(20)条に紐づく（労働安全衛生）規制第(157)条の(87)の適用例

労働安全衛生法第 20 条では、事業者は機械、器具その他の設備による危険等を防止するため必要な措置を講じるよう義務を課しており、より具体的な義務は労働安全衛生規則により膨大に定められている。この一例として、労働安全衛生法第 20 条に基づく労働安全衛生規則第 151 条の 87 の規定により、車両系木材伐出機械を使用する事業者は、当該機械について、運転者席に防護柵「等」を備えなくてはならない、と規定しているが、当該条文の要件を満たすためにどのようなものが「防護柵」として認められるかについては、行政解釈にゆだねられている。上記のとおり、条文の特徴として、労働安全衛生法の規定が非常に抽象的であり、具体的な措置義務は労働安全衛生規則の条文によることとあるうえ、さらに同規則においても、その定義が行政解釈にある程度ゆ



だねられていることから、実質、刑罰法規の適用の有無を行政解釈にゆだねている側面を有しているものである(これは法令の内容・性質上やむをえないことであると考え)(00147 監督官)

●主に労働安全衛生法第(20)条に紐づく(労働安全衛生)規制第(151)の78、82)条の適用例  
繰り返し(司法)

ベルトコンベアの清掃、調整後に試運転を行ったところ、被災者が持っていたタオルでモータープーリーの水分を拭き取ろうとして巻き込まれた。(00160 技官)

●主に労働安全衛生法第(20)条に紐づく(労働安全衛生)規制第(164)条の適用例

・道路建設工事現場などにおいて、クレーン機能付きドラグショベルを使用して荷のつり上げ(側溝ブロックの設置作業や転圧機等機械の積み込み・積み下ろし作業など)をしているにもかかわらず、クレーンモードに切り替えておらず、結果、ドラグショベルの用途外使用になっている例が見られる。堀削作業の延長でクレーン作業をする場合、作業者の意思が希薄になりがちになると思われる。(00074 監督官)

●主に労働安全衛生法第(20)条に紐づく(労働安全衛生)規制第(164)条の適用例

機体重量3tのクレーン仕様のドラグ・ショベルをクレーン仕様に切り替えずに、バケットの爪にワイヤーロープをひっかけて発電機を吊り上げてトラックの荷台に移動させていたもの。(00007 監督官)

●主に安衛法(20)条に紐づく安衛則(164)条1項の適用例 (23)

[違反条文内容] 車両系建設機械の主たる用途以外の使用の制限

[業種] その他の建築工事業

[あらまし] 解体用機械(コンクリート圧砕機)の用途外使用(二次下請を派遣法で適用) 【公表】(00057 監督官)

●主に労働安全衛生法第(20)条に紐づく(安全衛生)規則第(194)条の9の適用例

高所作業車を用いた作業を行わせるに際し、作業計画を定めなかったもの。(00055 監督官)

●主に安衛法(20)条に紐づく安衛則(256)条1項の適用例 (28)

[違反条文内容] 危険物を製造する場合等の措置

[業種] ねじ等製造業

[あらまし] 引火性の物をみだりに火気に接近させたもの 【公表】(00057 監督官)

●主に労働安全衛生法第(20)条に紐づく労働安全衛生規則第(274)条の適用例

被疑者株式会社は化学工業製品製造業を営む事業者、被疑者は同社の工場長として化学工業製品製造部門を統括し、労働者の安全管理を行うものであるが、被疑者は同社の業務に関し、同工場において、労働者に製造作業を行わせるに当たり、爆発または火災を防止するため、同設備の冷却装置、加熱装置及び攪拌装置の操作並びに異常な事態が発生した場合における応急の措置等に関する必要な規程を定めずに同作業を行わせ、もって爆発性の物、引火性の物等による危険を防止するための必要な措置を講じなかったものである。(00166 監督官)

●主に労働安全衛生法第(20)条に紐づく(労働安全衛生)規制第(563)条の適用例

足場の墜落防止や物体落下防止で違反を適用することが多い。(00107 監督官)

●主に労働安全衛生法第(20)条に紐づく(労働安全衛生)規制第(563)条の適用例

労働安全衛生起訴第 563 条第 1 項第 3 号ロで、わく組足場以外の足場においては、中棧等を設置する義務が設けられているものの、条文の冒頭において(一側足場を除く。第 3 号において同じ)との記載があることから、悪質な業者が敷地に十分な余裕があるにもかかわらず、この法令の適用を逃れるため、本足場ではなく、あえて中棧を抜いた一側足場を設置していたもの。しかしながら、設置された足場の全てのスパンを一側足場としていなかったことから、一側足場となっていないスパンを捉えて、違反を適用させたもの。

これを積極的に適用させるよう推し進めると、あえて、より危険な足場を選択する業者が発生し、違反を逃れると思料されるもの。(00040 監督官)

●主に労働安全衛生法第(20)条に紐づく(労働安全衛生)規制第(563)条の適用例

本足場の墜落防止措置の不備。手前欠落等。幅木、下さんがない。(物体落下防止措置の不備)(00167 監督官)

●主に労働安全衛生法第(20)条に紐づく(有機)規制第(5)条の適用例

第一種、第二種有機溶剤収扱作業場に局排が未設置であること。(00167 監督官)

●主に労働安全衛生法第(20)条に紐づく(クレーン等安全規則)規制第(66 の 2 第 1 項第 1 号)条の適用例

株式会社 A は、愛知県一宮市に本店を置き、木造建築工事業を営み、同県同士新築工事を施工する事業者、B は、同現場の現場代理人として、その施工及び労働者の安全を管理するものであるが、B は、同会社の業務に関し、平成 19 年、同工事現場において、労働者 C らをして、つり上げ荷重が 4.9 トンの移動式クレーンを用いて作業を行わせるにあたり、同クレーンの転倒による労働者の危険を防止するため、あらかじめ、移動式クレーンによる作業の方法、移動式クレーンの転倒を防止するための方法を定めなければならないのに、これを定めずに同作業を行わせ、もって、機械等による危険を防止するための必要な措置を講じなかったものである。

(00054 監督官)

●主に労働安全衛生法第(20)条に紐づく(クレーン等安全規則)規制第(66 の 2)条の適用例

作業計画の未完成(司法)。トラック荷台の荷上で玉掛け作業を行っていた被災者が地上に墜落した。(00160 技官)

●主に労働安全衛生法第(21)条に紐づく労働安全衛生規則第(151 条の 70 条)の適用例

住宅解体工事現場において、庭石(重さ 3 トン)を撤去するにあたり、バックホウを用いて貨物自動車に積み込む作業中に、庭石が崩れて近くに立っていた貨物自動車運転手に庭石が激突した。この作業を行わせるに際し、当該作業を指揮するものを定めていなかった。(00157 監督官または元監督官)

●主に労働安全衛生法第(21)条に紐づく(労働安全衛生)規則第(361)条の適用例

下水道工事のため溝掘削(明かり掘削)を行っていた際に、掘削箇所について地山崩壊が発生したが、土止め支保土を設けていなかったために是正勧告を行なった。(00121 監督官)

●主に労働安全衛生法第(21)条に紐づく(労働安全衛生)規則第(380)条の適用例

ずい道等の掘削の作業を行うときには、あらかじめ調査により知りえたところに適応する施工計画を定め、かつ当該施工計画により作業を行わなければならない(380 条)が、施工計画が観察、点検、測定等により知り得た地山の状態に適応しなくなったときは、当該計画を当該地山の状態に適応するよう変更し、変更した施工計画

によって作業を行わなければならない(383条)とされている。施工計画を変更しなかったとして383条違反で立件の構えであったが、検討の結果、383条は「地山の状態に適応しなくなったとき」に限定されるものであり、380条の施工計画に従わずに工事を進めた場合を想定していないと判断され、383条違反ではなく、380条違反で送検したという例あり。

「地山の状態に適応しなくなったとき」をどのように判断するか見解の割れた事案であったと記憶している。(00076 監督官)

●主に安衛法(21)条1項に紐づく安衛則384条の適用例(32)

[違反条文内容] ずい道等の建設の作業における落盤等による危険の防止

[業種] その他の土木工事業

[あらまし] 【公表】 ずい道内での落盤等による危険防止措置義務違反(00057 監督官)

●主に労働安全衛生法第(21)条に紐づく(安全衛生)規則第(477)条の適用例

労働者に立木を伐倒する作業を行わせる際に、退避する場所をあらかじめ定めていなかったもの。(00055 監督官)

●主に労働安全衛生法第(21)条第(1)項に紐づく(労働安全衛生)規制第(477)条第(1)項の適用例

立木を伐倒させる際、労働者にあらかじめ退避する場所を決めさせていなかったもの。

(00072 監督官)

●主に安衛法(21)条1項に紐づく安衛則(479)条1項の適用例(4)

[違反条文内容] 伐倒の合図

[業種] その他の林業

[あらまし] 伐木作業中に落下した伐倒木に激突された死亡災害【公表】(00057 監督官)

●主に安衛法(21)条1項に紐づく安衛則(484)条1項の適用例(5)

[違反条文内容] 造林等作業時における保護帽の着用

[業種] 木材伐出業

[あらまし] チェーンソーでの伐木作業において保護帽未着用及び特別教育を実施しなかった【公表】(00057 監督官)

●主に労働安全衛生法第(21)条1項に紐づく(労働安全衛生)規則(518)条の適用例

高さ二メートル以上の箇所で行う作業の際、作業床がなく墜落により労働者に危険を及ぼすおそれ認められたため、同条(同規則)に基づき違反を指摘した。(00174 監督官)

●主に労働安全衛生法第(21)条に紐づく(労働安全衛生)規則第(518)条の適用例

トラックの荷台に積まれた廃材にシートをかけるため、荷台の廃材の上に上り、シートを一部広げていたところ、2.3メートル下の地上に墜落。

被災時、被災者は保護帽及び墜落制止用器具を着用していなかった。

シートかけ作業時間は数分程度と短く、荷を積み終えたら直ぐにトラックを目的の場所まで移動させるため、足場の設置は困難なときに該当し、第2項を適用。(00173 技官)

●主に労働安全衛生法第(21)条に紐づく(労働安全衛生)規則(518)条の適用例

高さが2m以上の箇所で墜落により労働者に危険を及ぼすおそれのあるときは、足場を組み立てる等の方法により作業床を設けるとあるが、「作業床」の定義が不明確である。作業をするための必要最小限の面積を持つ床であれば作業床と認めても、墜落による危険のおそれがあればその面積は拡大されていく。行政指導であれば安全確保の目的のために広く解釈してよいであろうが、司法事件の場合には、厳格に解釈していかなければならない。(00076 監督官)

●主に労働安全衛生法第(21)条に紐づく(労働安全衛生)規則(518)条の適用例

輸送運搬機械製造会社で、同社所属の労働者3名が、工場建屋内壁面へ電源コンセントを増設する作業を行っていたところ、うち1名が地上から高さ3メートルの梁上からコンクリート床面に墜落し、死亡した。同社責任者は、電源コンセント増設作業を行わせるにたあり、作業場所は高さが2メートル以上で、足場を組み立てるなどの方法により、作業床を設けることが容易であったのに、これを設けず、もって労働者が墜落するおそれのある場所に係る危険を防止するために必要な措置を講じなかった。(00097 監督官)

●主に安衛法(21)条2項に紐づく安衛則(518)条2項の適用例(38)

[違反条文内容] 作業床の設置等

[業種] 機械修理業

[あらまし] 【公表】生産設備に組み込まれたクレーン点検作業中の墜落災害(00057 監督官)

●主に労働安全衛生法第(21)条に紐づく(労働安全衛生)規則第(519)条の適用例

個人宅の屋根に設置の太陽光発電システムの点検のため、はしごを使い屋根に上り当該発電システムを点検していたところ、屋根から5メートル下の地上に墜落。

被災者が点検していた屋根は、平面的な広がりをもった作業床であるが、囲いや手すりの設置はなく(囲い等を設けることが著しく困難なため、第2項適用)、防網を張らず、要求性能墜落制止用器具を使用させていない。(00173 技官)

●主に安衛法(21)条2項に紐づく安衛則(519)条1項の適用例(25)

[違反条文内容] 開口部等の囲い等

[業種] 鉄骨・鉄筋コンクリート造家屋建築工事業

[あらまし] 二次下請の労働者が屋根の開口部から墜落【公表】(00057 監督官)

●主に安衛法(21)条2項に紐づく安衛則(519)条2項の適用例(14)

[違反条文内容] 開口部等の囲い等

[業種] ビルメンテナンス業

[あらまし] 高さ2メートル以上の作業床からの墜落災害【公表】(00057 監督官)

●主に労働安全衛生法第(21)条に紐づく(労働安全衛生)規制第(519)条の適用例

建設現場の建物の端部や工場の床の端部などで、墜落防止がされていない箇所での適用が多い。(00107 監督官)

●主に労働安全衛生法第(21)条に紐づく(労働安全衛生)規則第(519)条の適用例

(労働安全衛生規則第(519)条1項・2項 労働安全衛生法第21条2項)

作業床の端や開口部からの墜落防止の条文であり、事業場において、この条文を適用する場面が比較的多くあります。



特に建設業においては事故の型で分類した場合のワースト1となる「墜落転落」による災害を防止する上でこの条文は重要であり、現場を確認する場合においても、まず、この条文が適用となる箇所が存在するか否か、また、工程が進むにつれて墜落する場面が生じないかについて検討しています。

#### 適用例1 建設現場

足場の端部に墜落防止用の手すりが設置していない場合(枠組足場の端部などが多い)  
足場の長手方向に手すりが設置されていない(又は作業の都合で取り外されている)場合  
床面のだめ穴の周囲に開口部養生又は墜落防止措置の手すりが設置されていない場合

#### 適用例2 建設現場以外

資材倉庫の2階部分の床端に手すりが設置されていない場合  
(中2階みたいな部分に資材等が積載されている場面が多い)  
(00133 監督官)

●主に労働安全衛生法第(21)条に紐づく(労働安全衛生)規制第(519)条の適用例  
一般住宅建築現場において、2階階段取付部の開口部に手すり等の設置が無かった例。  
(00112 技官)

●主に労働安全衛生法第(21)条に紐づく(労働安全衛生)規則第(519)条の適用例  
墜落災害発生時、手すり等が設置されていない場合に適用。(00162 監督官)

●主に労働安全衛生法第(21)条に紐づく(労働安全衛生)規則第(522)条の適用例  
強風、大雨の悪天候の日に、工期が迫っているからと高さ2m以上の屋根の張替え作業をさせたとして、事業主が違反に問われた。(00141 監督官2)

●主に労働安全衛生法第(21)条に紐づく(労働安全衛生)規則第(524)条の適用例  
スレート上で、屋根の解体作業をしているにもかかわらず、スレート踏み抜きを防止するための措置を講じておらず、当該条文に抵触したもの。(00089 監督官)

●主に労働安全衛生法第(21)条に紐づく(労働安全衛生)規則第(524)条の適用例  
この条文はスレート等の屋根上の危険防止の条文です。  
建物の解体や改修工事のほか、屋根上の清掃や屋根上を通行し、屋根端部の雨どいを清掃する場合など、関連災害は多く発生しています。  
外見は人が乗っても大丈夫なように見えますが注意が必要となります。  
屋根材のほかに明り取りのためのポリカーボネート製の材料や、ガラス(天窗)についても注意が必要となります。(特にガラスは大丈夫のようで案外強度がない)  
さらに、経年的な劣化により強度が著しく低下している例が多くあります。

#### 適用例

雨どいを清掃するため清掃箇所まで木毛セメント板屋根上を通行している場合  
明り取り用のガラス屋根上を清掃する際に、その上に誤って乗ってしまった場合  
(000133 監督官)

●主に安衛法(21)条2項に紐づく安衛則524条の適用例(13)  
[違反条文内容] スレート等の屋根上の危険の防止  
[業種] 機械(精密機械を除く)器具製造業

[あらまし] 屋根に設けられた天窓の踏み抜き【公表】(00057 監督官)

●主に労働安全衛生法第(21)条に紐づく(労働安全衛生)規制第(524)条の適用例

A社は、建築工事業を営む事業者である。木造平屋建ての自社倉庫の屋根が老朽化したため、労働者Bを使用して、同倉庫の屋根ふき替え工事を行った。屋根は切妻屋根と呼ばれる形状で、断面が波形した薄い鉄板(いわゆるトタン板)でふかれており、棟の高さ 600 c m、軒の高さ 440 c m、地面はコンクリートであった。屋根の鉄板は腐食が進んで錆び付き、亀裂、穴等の損傷個所が生じていて、雨天時は雨漏りする状態であった。労働者Bは、屋根の上に上がり、屋根の吹き替え作業を行っていたところ、鉄板を踏み抜いて約 5m下のコンクリートの地面に墜落し、死亡した。踏み抜きにより、労働者に危険を及ぼすおそれがあったのに、屋根に幅が 30 c m以上の歩み板を設け、防網を張る等踏み抜きによる労働者の危険を防止するための措置を講じなかったものである。(00087 監督官)

●主に労働安全衛生法第(21)条に紐づく(労働安全衛生)規則第(524)条の適用例

平屋建て工場の屋根の補修工事を行う現場において、スレートで葺かれた屋根の上に幅 24 センチメートルの足場板を歩み板代わりに使用していたため、幅 30 センチメートル以上の歩み板を設けるよう指導したこと。(000155 不明)

●主に労働安全衛生法第(21)条に紐づく(労働安全衛生規則)規則第(526)条の適用例

この条文は作業場所に高低差がある場合に安全な昇降設備を設置させ使用させることを規定しています。適用例が多いのは建設現場に設置している足場において、昇降設備が設けられていないがために足場の外面をよじ登って昇降する事例が多く、その場面で墜落する事例があります。足場を設置するスペースに余裕がある場合には、枠組足場等の条件の良い足場が設置できるためその中に階段枠を設置することにより安全に昇降可能となりますが、狭隘な部分に設置する単管ブラケット足場や単管抱き足場などについては、昇降設備を設置できない場合が多く、この規則の適用となります。

是正方法としては、狭隘な部分については足場と躯体の間に梯子を設置したうえで昇降時にロリップを使用して安全を確保し、足場から躯体への渡りを設けて既設の建物階段を使用するなどの対応をしています。(000133 監督官)

●主に安衛法(21)条1項に紐づく安衛則(529)条の適用例(1)

[違反条文内容] 建築物等の組立て、解体又は変更の作業における作業指揮者の指名ほか

[業種] その他の建設業-その他

[あらまし] 脚立からの墜落死亡災害【公表】(00057 監督官)

●主に労働安全衛生法第(21)条に紐づく(安衛)規則第(534)条の適用例

明り掘削 水管敷設現場にて、土止支保工を講じず掘削面崩壊による事案について、埋もれた被災者所属事業者に適用。(00058 監督官)

●主に労働安全衛生法第(22)条に紐づく(有機)規則第(5)条の適用例

- ・屋内作業場で塗装しているのに、局所排気装置が設けられていない。
- ・局所排気装置は設けられていても、制御風速が足りない。(00027 監督官)

●主に労働安全衛生法第(22)条に紐づく(特定化学物質障害予防)規則第(22)条の適用例

製紙会社工場において、労働者 2 名が、アンモニア水タンクと液面計との間に設置されたボールバルブの閉止作業中、ボールバルブのフランジ部が破断・脱落し、アンモニア水が吹き出し、両名が被液し、うち 1 名が死亡した。同社は、ボールバルブの閉止作業に従事する労働者に、保護衣、呼吸用保護具等必要な保護具を使用させず、もってガス等による健康障害を防止するための必要な措置を講じなかった。(00097 監督官)

●主に労働安全衛生法第(22)条に紐づく(有機溶剤中毒予防)規制第(5)条の適用例

第二種有機溶剤を使用した塗装を行っているにもかかわらず、局所排気装置等の設置が無かった例。(00112 技官)

●主に労働安全衛生法第(22)条に紐づく(有機溶剤中毒予防)規制第(5)条の適用例

有機溶剤業務において、局所排出装置が作業場所からやや離れた場所に御剤しており、適切な場所に局所排出装置が設置されておらず、結果として当該条文に抵触したもの。(00089 監督官)

●主に労働安全衛生法第(22)条に紐づく(石綿障害予防)規則第(6)条の適用例

立体駐車場解体工事を頼まれ、鉄骨に吹き付け材が付着しており、石綿含有していることを知りながら、隔離養生し負圧にする措置を講じず、解体工事施工を命じたことを違反に問われた。(00141 監督官 2)

●主に労働安全衛生法第(22)条に紐づく有機溶剤中毒予防規則などの適用例

有機溶剤中毒予防規則等の適用について、別途スライドで作成しました：

「20201120 労働安全衛生法講座②(有機溶剤中毒予防規則の適用例).pptx」(番号なし 監督官)

●主に労働安全衛生法第(22)条に紐づく(粉じん障害防止)規則第(27)条の適用例

金属アーク溶接作業に従事させていたにもかかわらず、労働者に防じんマスクを使用させていなかったため、是正勧告を行なった。(00121 監督官)

●主に労働安全衛生法第(22)条に紐づく(特定化学物質障害予防)規則第(38 条の 14) の適用例

養鶏場において、一定の日齢を迎えた鶏は、次の鶏舎に移している。空になった鶏舎は水洗浄した後、消毒するため、ホルムアルデヒドをドラム缶に入れ、薬剤を投入し一昼夜鶏舎内を燻蒸する。ラム缶に入ったホルムアルデヒドに薬剤を入れる作業に労働者を従事させており、当該業務は鶏舎内にかつ送気マスク等の呼吸用保護具を使用せず行っていたため、特化則 38 条の 14 第 1 項 2 号違反を指摘した。(00035 監督官)

●主に労働安全衛生法第(22)条に紐づく(労働安全衛生)規制第(585)条の適用例

立入禁止の表示をしていない。(00005 監督官)

●主に労働安全衛生法第(22)条に紐づく(労働安全衛生)規制第(578)条の適用例

(司法)石綿除去作業中、隔離養生した屋内作業場で内燃機関(発電機)を稼働させたことにより 6 名が一酸化炭素中毒となった。(00160 技官)

●主に労働安全衛生法第(23)条に紐づく(労働安全衛生)規制第(540)条の適用例

鉄工工場において、工場内に安全通路が設置されていたものの形骸化しており、扱う資材(H鋼)に長尺物が多いため、労働者が移動する際に、安全通路では無い積み上げた資材の上を跨いでショーカットして通行している状況を確認したため、当該条文を適用させ、違反を指摘したもの。是正報告においては、当該箇所の通行の

際には、安全通路を通行するように労働者に徹底させるとの報告があり、完結させている。しかしながら、2年経過後、別途臨検を実施した際、移動のため、積み上げたH鋼を跨ぐ労働者を確認したが、通路ではなく、当該H鋼にかかる作業のために資材を跨いでいた状況のため違反としては適用しなかったもの。長尺物のH鋼については、H鋼の形状にもよるが、変形した板木を敷いて積むと倒れて挟まれる危険性があるため、H鋼の上に板木を敷いてH鋼を積み上げないようにし、板木の形状等点検の徹底などの対策例を説明し指導するにとどまったもの。

作業場内における移動箇所を「通路」として認定し適用した事例と適用しなかった事例及び、本質安全の改善にまで至っていなかった例。(00040 監督官)

●主に労働安全衛生法第(23)条に紐付く(労働安全衛生)規則第(540)条の適用例

作業場に通じる場所及び作業場内に労働者が使用するための安全な通路を設ける義務を課しているが、「安全な通路」が曖昧である。規則 541 条(照明)、542 条(屋内に設ける通路)、543 条(機械間の通路)の条文はあるが、これらの条文と同程度であれば安全といえるのか。労働災害があれば安全な通路ではなかったとして違反指摘をしているが、「安全な」の程度を明らかにしておくべきと考える。高齢化が進み転倒災害が多くを占めており、災害防止のためにこの条文は重要である。(00076 監督官)

●労働安全衛生法第(23)条に紐付く労働安全衛生規則第(544)条の適用例

冬、労働者が、事業場の敷地内で、凍結した地面（アスファルト）で転んで地面に頭部を打って死亡した災害がありました。是正勧告レベルで罰則は適用していませんが、路面凍結防止剤を使用しなかったとして、本条を適用しました。しかし、可罰性があるのかという問題になり（厳密に言えばあるのかもしれませんが）、是正勧告に止めました。(番号なし 監督官)

●主に労働安全衛生法第(30)条に紐づく(労働安全衛生)規制第(635)条の適用例

建設現場において、特定元方事業場が、関係請負人の労働者の作業が同一の場所において行われることによって生ずる労働災害を防止するための協議組織を設置し、定期的に開催していなかったもの。(00212 監督官)

●主に安衛法(30)条1項に紐づく安衛則 637 条1項の適用例 (31)

[違反条文内容] 特定元方事業者の作業場所の巡視

[業種] 建築設備工事業

[あらまし] 【公表】作業場所の巡視義務違反(00057 監督官)

●主に労働安全衛生法第(30)条に紐づく(労働安全衛生)規制第(683)条の4及び同法第(20)条紐づく(クレーン等安全)規則第(66条の2)の適用例

複数の関係請負人の労働者が混在して作業に従事するマンション新築工事現場において、複数の関係請負人の労働者が共同して、つり上げ荷重が3トン以上の移動式クレーンを用いた型枠材料の搬出作業を行っていたところ、つり荷の型枠材料が落下し、下方で作業していた複数名の労働者が死傷したが、元方事業者は、関係請負人が定めなければならないクレーン等安全基則第66条の2の定める事項について、自らが定める計画に適合するよう指導しておらず、また、共同して可動式クレーンを用いた作業を行っていた複数の関係請負人は、いずれも同条に定める事項を定めずに作業を行っていたことから、労働基準監督署は、元方事業者及び共同して移動式クレーンを用いた作業に労働者を就かせていた各関係請負人をどう労安全衛生法違反の疑いで書類送検した。(00078 監督官)

●主に労働安全衛生法第(31)条に紐づく(労働安全衛生)規制第(653)条の適用例



建設現場における墜落防止対策が不十分なことによる注文者への適用が多い。(00107 監督官)

●主に労働安全衛生法第(31)条に紐づく(安全衛生)規則第(653)条の適用例

労働者に高さ約 8 メートルの物品揚卸口を使用させる際に、墜落防止措置を講じなかったもの。(00055 監督官)

●主に安衛法(31)条 1 項に紐づく安衛則 653 条 1 項の適用例 (24)

[違反条文内容] 物品揚卸口等についての注文者の措置

[業種] 鉄骨・鉄筋コンクリート造家屋建築工事業

[あらまし] 二次下請の労働者が屋根の開口部から墜落【公表】(00057 監督官)

●主に労働安全衛生法第(31)条に紐づく(労働安全衛生規則)規則第(655)条の適用例

元請け人(注文者)が、下請け人の労働者に足場を使用させているにもかかわらず、墜落防止用の手すりの設置が不十分で結果として必要な措置を請じていないことから注文者の講ずべき措置を講じていなかったとして、当該条文に抵触したもの。(00089 監督官)

●主に労働安全衛生法第(31 条の 2)条に紐づく(労働安全衛生)規則第(662 条の 4) 条の適用例

化学工場において、協力企業の労働者が一酸化炭素の製造設備に設置された機器を清掃するため、マンホールを分解する作業を行うに際して、他系列の一酸化炭素製造設備は稼働中であって、当該機器に接続している配管に一酸化炭素が滞留しており、配管に通じる弁を誤って開放することにより一酸化炭素が漏出する危険があることが関係協力企業に周知されていなかったために、別協力企業の労働者が当該機器に接続する配管に設置された自動弁本体部に点検整備を終えた駆動装置を取り付ける作業中、誤って当該自動弁を開けてしまった際に、稼働中の他系列から配管に滞留していた一酸化炭素が大量漏出し、協力企業の労働者等が一酸化炭素を吸引して 15 名(うち死亡 1 名)が被災した。

(この事例は当該条項が直接適用されたものではありませんが、その新設(H18.4.1 施行)に関与したと思われる典型的な事例です。災害発生当時(H15.7)の法令でも、特化則第 22 条により、特定化学設備の改造等の作業を直接雇用する労働者に行わせる事業者には、特定化学物質の流出等による災害を防止するための具体的な措置が義務付けられていましたが、下請負事業者に設備を所有管理する事業者(注文者)からの的確な情報の開示や指示が行われておらず、当事者に危険有害性に関する認識がなかったことが、この事例の災害発生原因となったものです。)(00088 元監督官)

●主に労働安全衛生法第(31)条に紐づく(労働安全衛生)規制第(655)条の適用例

建設現場における墜落防止対策が不十分なことによる注文者への適用が多い。(00107 監督官)

●主に労働安全衛生法第(31)条に紐づく(労働安全衛生)規制第(655)条の適用例

建設現場において、特定元方事業者(注文者)が関係請負人の労働者に対し足場を使用させる際、安衛則第 563 条に定める足場用墜落防止措置等を設けていなかったことから、特定元方事業場について安衛法第 31 条(安衛則第 655 条)違反を認めたもの。(00212 監督官)

●主に労働安全衛生法第(38)条に紐づく(クレーン等安全)規制第(6)条の適用例

ボート及びヨットの係留場に設置されたクレーンについて、当該事業場は、法律設立以来、代表者 1 名しか存在してこなかった状況であるため、労働者が不在であり、定義上「事業者」に該当する者も存在しない。クレーン等安全規則第 6 条においては、主語が「クレーンを設置した者」であるため、これを適用させ、違反を指摘

したもの。

労働安全衛生法第1条の目的に合致しない趣旨に基づく違反の指摘を実施している例。(00040 監督官)

●労働安全衛生法(第45条)の適用例

主に労働安全衛生法第(20)条に紐付く(労働安全衛生)規則第(131)条)の適用例

安全プレスについて、中古品の場合、当該安全プレスに改造が施され、本来有している安全プレスとしての機能を有していないものが存在する。

このような場合、労働安全衛生法第20条(労働安全衛生規則第27条)が成立すると考えられるが、改造を施した者が、当該改造やそもそも安全プレスであることを知らないような場合は、もはや安全プレスでは無いとして、同法第0条、同則第131条第2項、第3項を適用させている。

(00170 不明)

●主に労働安全衛生法第(45)条に紐づく(労働安全衛生)規制第(151)条の(21、1)項の適用例

フォークリフトの年次検査(特自検)の未実施等。(00167 監督官)

●主に労働安全衛生法第(45)条に紐づく(労働安全衛生)規制第(151)条の(24)項の適用例

事業者Aは特定自主検査事業者であるBに依頼して、特定自主検査を行っていただくが、Bは特定自主検査を実施する必要が生じた。労働安全衛生規則第151条の21においてフォークリフトの定期地涌検査を義務付け、同定期自主検査については労働安全衛生規則第151条の24で特定自主検査を行っていなかった場合には労働安全衛生規則第151条の21違反となり、労働安全衛生既読第151条の24だけの違反となるのは、労働安全衛生既読第151条の21に基づく定期自主検査を行っていたものの、特定自主検査を行う資格がないものが実施した場合に限られている。(00206 監督官)

●主に安衛法45条1項に紐づく特化則31条1項の適用例(6)

[違反条文内容] 特定化学設備又はその附属設備の定期自主検査

[業種] その他の化学工業

[あらまし] 第三類物質(硝酸)を取り扱う管理特定化学設備(硝酸槽)の爆発事故【公表】(00057 監督官)

●主に労働安全衛生法第(59)条第3項に紐付く(安全衛生)規則第(36)条の適用例

危険又は有害な業務に就く労働者に対して厚生労働省告示等で定める特別教育規程の基づいた特別教育を実施していない場合、適用する。(00196 監督官)

●主に労働安全衛生法第(59)条に紐付く(労働安全衛生)規則第(36)条の適用例

鋼材卸会社の倉庫において、業者が搬入してきた荷(鉄板)を吊り上げ荷重5トン未満の天井クレーンを使用して吊り上げ移動させていたところ、運転者(クレーン運転特別教育を受けていない者)が運転操作を誤ったため鉄板が外れて落下し、下方にいた納入業者の労働者が下敷きになって死亡する災害が発生。

日ごろから特別教育未実施の労働者がクレーンの運転を行い、それを黙認していたことの認識があったことから違反として送検。正式裁判の結果、罰金刑が確定した。(00141 監督官1)

●主に労働安全衛生法第(59)条に紐づく(労働安全衛生)規制第(36)条の適用例

各種特別教育の未実施。(00163 監督官)

●主に労働安全衛生法第(59)条に紐づく(労働安全衛生)規制第(36)条の適用例

「事業者Aは、安衛則第37条に規定する法定の除外事由がないにも拘らず、労働者Bを(安衛則第36条第○号)

の業務につかせるにあたり、法廷の特別教育を行わなかった」として労働基準監督署は事業者に対し、是正勧告した。

実務家からした課題：

※(1)法定除外事由の解釈の幅広さ

特別教育の科目の全部または一部について「十分な知識及び技能を有する」労働者については安衛則第 37 条により当該科目の省略が認められているが、その該当性の判断はいくつかの行政解釈等が示されているものの、なお事業者により解釈の幅があるのが現実であり、運用に当たっては注意が必要である。

(2) 刑罰法規として運用上の課題

上記(1)のとおり安衛則第 37 条の解釈に幅があることが、刑罰法規としての安衛法の同条項の運用に当たってのハードルを高めている。

(例)特別教育を受けていない労働者が当該業務中の労災事故で死亡したことを契機に、特別司法警察員としての労働基準監督官が法第 59 条違反の刑事事件として立件するケースはありふれている。その際の検査における採証活動について見てみると、被災労働者は既に死亡して本人の人証が得られないため、「被災労働者の過去の職歴等に鑑みると科目の省略可ではないか」との反証をつぶすための捜査に相当の困難を伴うことも珍しくない。

このように、安衛法第 59 条を刑罰法規の面から評価すると、特別教育の科目省略への事実関係の当てはめは悩ましい問題である。(00268 元監督官)

●主に労働安全衛生法第(59)条に紐付く(労働安全衛生)規則第(36)条の適用例

ある事業場で、「高圧又は特別高圧電気取扱業務に係る特別教育」を修了した労働者に対し「低圧電気取扱業務」を行わせていた事案について指摘したところ、当該事業場は「高圧若しくは特別高圧の充電電路の点検修理の方が危険度は高く、その特別教育を修了した労働者に、危険度の低い低圧充電電路の修理を行わせていたものであり、上位の特別教育を修了しており、問題はない」と抗弁したもの。

しかしながら、労働安全衛生規則第 36 条第 4 号には、例えば「高圧・特別高圧の特別教育を受けた場合には、低圧の特別教育について一定の科目について省略してよい」という規定はなく、その逆もない。つまり両特別教育は上位下位の関係にあるものでは無く、それぞれの領域での安全に関して必要とされる知識を付与するものであり、当該業務に従事する場合には、それぞれの特別教育を修了する必要があるものであること。

特別教育の科目の省略については、安全衛生規則第 37 条に「特別教育の科目の全部又は一部について十分な知識及び技能を有していると認められる労働者については(略)省略することができる」と規定されている。この条文の関係通達において「当該業務に関連し上級の資格(技能免許又は技能講習修了)を有する者、他の事業場において当該業務に関し、既に特別の教育を受けた者(略)等がこれに該当する」(昭 48.3.19 基発第 145 号)とされており、上位の資格とは技能講習修了等であり、他の特別教育は上位の資格に該当しないものである。

法律、規則、通達の構成は上記の通りであり、解釈は明白であるが、規則の表記が「十分な知識及び技能を有していると認められる労働者については(略)省略することができる」というものであり、「有していると認められる」と判断するのが誰かということが、条文上は明らかでなく、この点が上記の事業場のような取り扱いを招いていると言えなくもないものである。(000248 元監督官)

●主に労働安全衛生法第(59)条に紐付く(労働安全衛生)規則第(36)条の適用例

建設業の A 社は、請負った公園のフェンス補修工事を開始して間もなく、公園の雑木が工事に支障をきたすおそれがあると判明した。

このため、以前から知り合いであった B に公園の雑木の伐木作業を急遽依頼し、1 日限りの臨時社員として雇用した。



A社は、労働者Bに厚生労働省令で定める危険な業務であるチェーンソーを用いて行う立木の伐木業務に就かせるに当たり、同人に対し、法定の当該業務に関する安全のための特別の教育を行わなかったものである。

その結果、雑木の伐木を行った直後、当該雑木に寄り掛かっていた別の木の枝が折れて落下し、Bを直撃したものである。

- ・Bは自営業の傍ら、他人から頼まれて、住宅の庭木等の伐木作業を何年も前から行っていたものである。
  - ・A社には伐木作業の経験のある者はおらず、A社はBを1日限りの臨時雇用とし、Bの前記の経歴から、作業開始に当たり、Bに対し、作業内容を説明したのみであった。
  - ・Bは勤め人の経験はなく、登録教習機関が行う各種技能講習、特別教育等を受講したことはなかった。
- (000127 監督官)

●主に労働安全衛生法第(59)条に紐付く(労働安全衛生)規則第(36)条の適用例

金属加工業を行う工場において、動力プレスの金型の取り外し作業を特別教育を修了していない者に行わせていたことから、当該作業者に特別教育を受講させるよう指導したもの。(000155 不明)

●主に労働安全衛生法第(59)条に紐付く(安全衛生)規則第(36)条の適用

クレーンの運転業務にかかる特別教育を行わずに労働者をクレーンの運転業務に従事させたもの。(00055 監督官)

●主に安衛法(59)条3項に紐づく安衛則(36)条15号の適用例 (21)

[違反条文内容] 特別教育を必要とする業務

[業種] その他の金属製品製造業

[あらまし] クレーン運転特別教育の未実施(死亡災害) 【公表】(00057 監督官)

●主に労働安全衛生法第(59)条に紐付く(労働安全衛生)規則第(37)条の適用例

事業者は、危険又は有害な業務に労働者をつかせるときに特別の教育を行う義務があるが、十分な知識及び技能を有していると認められる労働者については、特別教育を省略することができるとされているが、「十分な知識及び技能を有している」かどうかの認定が甚だ困難である。長年(特別教育の記録保存は3年)当該業務に従事しておれば、特別教育程度の内容であれば十分な知識及び技能を有していないとは認めがたいものと考えている。

長年作業に従事している労働者を特別教育の不実施で司法処分することは消極に解している。(00076 監督官)

●主に労働安全衛生法第(59)条に紐付く(労働安全衛生規則)規則第(38)条の適用例

特別教育を実施した場合には、労働安全衛生規則第38条において「当該特別教育の受講者、科目等の記録を作成して、これを3年間保存しておかなければならない」旨規定されている。

ある事業場において、「特別教育は実施したが、記録は作成していない」と説明があり、労働安全衛生規則38条違反を構成する旨、説明していたところ、当該事業場より「今後、記録は作成するが、修了証はどのようなものを作成すればよいのか、法律の規定を教えて欲しい」との質問が出された。

当該質問に対し、次のように回答したもの。

「特別教育実施の記録は義務付けられているが、修了証の作成・交付は義務付けられていない。事業場内での作業であれば問題は無いが、出先等の作業で、かつ下請として入場した現場等で元請等に修了確認を求められた場合には、作成・交付していないと困るケースも想定される。法定の様式は示されていないものであり、「安衛法に基づく特別教育の名称」「修了番号」「修了者氏名」「生年月日」「修了年月日」「交付年月日」「事業者名」「印」等の事項が記載されていれば良いのではないかと。」

就業制限を定めた安衛法第 61 条第 3 項には「これに係る免許証その他その資格を証する書面を携帯していなければならない」と規定されている。これに対し、特別教育を規定した安衛法第 59 条には対応する規定が存在しない。従事する業務の危険度の違いにより、求められる技能レベルが異なり、就業制限と特別教育とに分けられているのはその通りであるが、いずれも法により規定された資格であると捉えた場合、その証する書面の携帯について取り扱いを異にする理由の説明には窮する場面も多く、特別教育についても安衛法第 59 条に同様の規程があっても頷けるのではないかと思うものである。(000248 元監督官)

●主に安衛法(61)条 1 項に紐づく安衛令 20 条 16 号の適用例 (17)

[違反条文内容] 就業制限(業務に就かせてはならない)

[業種] ねじ等製造業

[あらまし] 無資格者によるクレーンの玉掛けの繰り返し違反【公表】(00057 監督官)

●主に安衛法(61)条 2 項に紐づく安衛令 20 条 16 号の適用例 (20)

[違反条文内容] 就業制限(何人も行ってはならない)

[業種] 木造家屋建築工事業

[あらまし] 【公表】玉掛け無資格作業(00057 監督官)

●主に労働安全衛生法第(61)条に紐づく(労働安全衛生)規則第(41)条の適用例

就業制限違反。(無資格)(00163 監督官)

●主に労働安全衛生法第(61)条に紐づく(労働安全衛生)規則第(41)条の適用例

最大荷重 1 トン以上のフォークリフトについて、道路交通法の適用の無い工場敷地内を荷役装置の操作を行わずに走行させる業務を、フォークリフト技能講習を修了してない労働者に対し指示し行わせたもの。

就業制限を定めた労働安全衛生法第 61 条に基づく安衛令第 20 条第 11 号は「最大荷重が 1 トン以上のフォークリフトの運転(道路上を走行させる運転を除く)の業務」と規定されている。ここでいう「道路」とは、安衛令第 20 条第 7 号において「道路交通法第 2 条第 1 項に規定する道路」(以下この条において「道路」という)とされており、同令第 11 号にて規定された最大荷重 1 トン以上のフォークリフトもこれに該当する。

よって、この規定で除外されているのは「道路上を走行させる運転」の業務のみであり、工場敷地内を走行させる運転については除外されていない。即ち、荷役装置の操作を行わずに工場敷地内を走行させるだけでも、安衛法第 61 条の就業制限から外れることにはならず、フォークリフト技能講習を修了した労働者に行わせる必要があるものであり、就業制限についての資格を定めた労働安全衛生規則第 41 条違反を構成することとなる。

分かりやすい条文の表記方法から見た場合、第 11 号だけを読むと「道路上を走行させる運転を除く」とあり、当該事業場のような誤解も招きかねない表記と言えないこともないのではないかと思う次第である。

(000248 元監督官)

●主に労働安全衛生法第(61)条に紐づく(労働安全衛生)規則第(41)条の適用例

建設現場で使用されている足場(わく組足場以外の足場)について、手すりが設けられていない箇所があったため、元書事業者に対して労働安全衛生規則第 655 条違反を指摘した。なお、同現場で足場を実際に使用して作業を行う下請け事業者に対しては、労働安全衛生法第 20 条(労働安全衛生規則第 563 条)の違反を指摘した。(00082 監督官)

●主に労働安全衛生法第(61)条に紐づく(クレーン等安全)規則第(221)条の適用例

新築ビル工事現場において、元請より「外部足場の組立・解体工事」を請け負った下請建設会社の作業員 5 名が、工事現場敷地内の吊り上げ過重 1 トン以上の移動式クレーンを用いて、高さ 10 メートルの足場上から、不要となった足場資材を地上に降ろす作業を行った。

5 人の作業員は、高さ 10 メートルの足場上で資材を緊結し、そのうち作業員 A が玉掛を行い、移動式クレーンのフックに取り付け、3 メートルほど吊り上げたところ、突然、玉掛した資材が崩れ落ち、作業員 A を直撃。作業員 A は、崩れ落ちた資材と共に地面に墜落した。

作業員 A は、頭蓋骨骨折、脳挫傷のため死亡。

玉掛を行った作業員 A は、労働安全衛生法第 61 条（就業制限）に基づく、クレーン等安全規則第 221 条（「令 20 条第 16 号」に定められた「吊り上げ荷重が 1 トン以上の移動式クレーンの玉掛の業務」）において規定された、同作業を行うに必要な「玉掛技能講習」を修了していなかったことが明らかとなり、同条文違反が認められたもの。

なお、共に資材の緊結作業を行った他の 4 名の作業員も、同じく玉掛技能講習を修了していなかった。

本件における違反については、上記の通り就業制限に係る事項が認められるが、災害の発生原因及び再発防止の観点に着目すれば、問題点は「玉掛方法の不具合」と「吊り上げられた荷の下に労働者がいた」という点である。

これについては、本件クレーンが吊り上げ荷重 1 トン以上の移動式クレーンであることから、クレーン等安全規則の適用があり、クレーン等安全規則第 29 条が検討条文となる。

同規則第 29 条では、「作業の形態等によりやむを得ない場合があることから、労働者の立ち入りを禁止する範囲は、特に災害発生状況等から（略）限定したものである」（平 4.8.24 基発第 621 号）とし、同規則第 29 条に掲げるもの以外については立入を認めている。

当然、同規則第 29 条違反となる事案もあるが、本件は、「玉掛の不具合」「玉掛方法」とも同規則第 29 条の適用がなく、再発防止の観点から言えば就業制限違反から導かれる「無資格者による作業禁止」に留まるものである。実効性ある再発防止対策は「荷の下の立入禁止」であるとする、一定の条件のもと、立ち入りを認めている同規則第 29 条について、以後の災害の発生状況から見た、除外条件の再検討が、必要と思われる。（000248 元監督官）

#### ●主に労働安全衛生法第(61)条に紐づく(クレーン)規制第(221)条の適用例(司法)

代表者 A は、トラックの二大に積まれていた 5 枚の鉄板のつり具で玉掛けし、つり上げ荷重 2.85 トンの天井クレーンでつり上げた。その後、床面に下ろす途中に上の 4 枚の鉄板が滑り落ち、一番下の鉄板がつり具から外れ倒れて近くにいた男性従業員に当たった。同人がその下敷きになり、頭部を負傷し、意識不明となった。A は、「つり上げ荷重が 1 トン以上のクレーンの玉掛けの業務」の資格を有していないにもかかわらず、当該業務を行った。（00053 監督官）

#### ●主に労働安全衛生法第(65)条に紐づく(有機溶剤中毒予防)規則第(28)条の適用例

有機溶剤を含有する製剤を用いて製品の脱脂洗浄を行う屋内作業場において、作業環境測定が全く行われていなかったことから、6 か月以内ごとに 1 回、定期的に作業環境測定を行うよう指導したもの。（00155 不明）

#### ●主に労働安全衛生法第(66)条に紐づく(有機溶剤中毒予防)規則第(29)条の適用例

IPA(イソプロピルアルコール)含有の洗浄剤を使用して金属製品の洗浄を行っていた労働者について、有機溶剤に係る特殊健康診断を行っていないため、是正勧告を行なった。（00121 監督官）

#### ●主に労働安全衛生法第(66)条に紐づく(労働安全衛生)規則第(44)条の適用例

定期健康診断実施についての条文になります。

事業場において労働者に健康診断を実施していない場合において、この条文が適用になります。

但し対象者は常時使用する労働者となっているので、この部分の確認は必要となります。

併せて結果の通知（法 66 の 6 ・規則 51 条の 4）

監督署への健康診断結果報告(法 100 条・規則 52 条)についても確認して違反があれば適用します。(00133 監督官)

●主に労働安全衛生法第(66)条に紐付く(労働安全衛生)規則第(44)条の適用例

常時、使用する労働者に対する定期健康診断を行っていなかったことが認められたため、同条(同規則)に基づき違反を指摘した。(00174 監督官)

●主に労働安全衛生法第(66)条に紐付く(労働安全衛生)規則第(44)条の適用例

労働者 30 名規模の製造業の事業場に於て、定期健康診断の実施状況を確認したところ、「各自に任せている」とし、事業場が主体で行っていない事が判明したため適用した。

(00130 監督官・技官)

●主に労働安全衛生法第(66)条に紐付く(労働安全衛生)規則第(48)条の適用例

ドラフトチャンバー内で、発煙硝酸を使用し、電子部品の検査業務を行っている労働者に対し、年 1 回の一般健康診断のみ実施し、6 月以内ごとに 1 回、定期的に歯科医師による健康診断を行っていなかったもの。(00035 監督官)

●主に労働安全衛生法第(66)条の(4)に紐づく(労働安全衛生)規制第(51)条の(2)適用例

定期健康診断の有所見者に対する医師からの意見聴取を行っていなかった例。(00112 技官)

●主に労働安全衛生法第(66)条の(4)に紐づく(労働安全衛生)規制第(52)条の(2)適用例

健診で異常所見のあった者に対する医師の意見聴取未実施。(00163 監督官)

●主に労働安全衛生法第(66)条に紐づく(労働安全衛生)規制第(44)条の適用例

健康診断の対象、頻度、項目について詳細を省令に委任。(00177 監督官)

●主に労働安全衛生法第(77)条に紐づく規制第(20~24)条の適用例

記入なし。(00259 監督官)

●主に労働安全衛生法第(88)条に紐づく(労働安全衛生)規制第(90)条の適用例

高さ 31m 超え建設物の建設・破壊・改造の仕事に係る 88 届の未提出。(00167 監督官)

●労働安全衛生法第(100)条に紐づく労働安全衛生規則第 96 条の適用例

労働安全衛生規則第 96 条第 1 項第 5 号イにより移動式クレーンの転倒事故が発生したときは、所轄労働基準監督署長に事故報告書の提出義務がある。

一方労働安全衛生法施行令別表 7 に掲げる建設機械の解釈として、昭和 47 年 9 月 18 日付け基発第 602 号で、移動式クレーンにバイブロ・ハンマーなどをセットしたものは、建設機械－基礎工事用機械－くい打機に該当する旨が示されている。

即ち、移動式クレーンが転倒したときでも、建設機械となるアタッチメントを取り付けた場合には報告対象とはならないものである。



上記事例による就業制限の取り扱い（移動式クレーン運転士免許等が必要なのか、車両系建設機械運転技能講習が必要なのか）も同様の考えとなる。（関係条文は上記と異なる）

更に、移動式クレーンの検査証・定期自主検査であるか、車両系建設機械としての特定自主検査であるかも同様である。（関係条文は上記と異なる。（00189 技官）

●主に労働安全衛生法第(100)条に紐づく(労働安全衛生)規制第(97)条の適用例（司法）

A 社工場の労働者が、溶接ロボットのトラブルの報告を受け、そこへ向かおうとして階段を下り終わったところ、床面のマットフチの枠に左足が乗り時ひねって左足を骨折し、療養のための休業は4日以上(休業26日間)に及んだ。休業4日以上(労働災害)については、労働者死傷病報告(様式第23号)を所轄労働基準監督署長に遅滞なく、提出しなければならないにもかかわらず、被災労働者の上司は、その措置義務を果たさなかった。(00053 監督官)

●主に安衛法(100)条1項に紐づく安衛則97条1項の適用例（8）

[違反条文内容] 労働者死傷病報告の提出

[業種] その他の食料品製造業

[あらまし] 労災かくし【公表】(00057 監督官)

●主に労働安全衛生法第(100)条に紐づく(安全衛生)規則第(98)条の適用例

労災隠し等災害の発生状況が不明な場合、事業者に対して、本条に基づく報告書の提出、出頭を命ずる通知の際、適用する。

なお、通知した報告・出頭に応じなかった場合、又は虚偽の報告をした場合は安衛法第120条第5号に該当する。(00196 監督官)

-----  
●条文と省令の紐づきについては、厚労省本省が所有する災害調査後令書を参照するのが最も効率がよい情報収集であると思います。(00161 技官)

質問2

【2-本法関係】

●労働安全衛生法第(10・11・12・13)条の適用例

衛生管理者の選任の規定になります。

常時50人以上の労働者を使用する事業場において、衛生管理者の選任が必要となり、選任されていない場合に適用となります。

また、事業場の安全衛生管理体制に関連して

総括安全衛生管理者 労働安全衛生法10条

安全管理者 労働安全衛生法11条

産業医 労働安全衛生法13条 についても確認し、選任の必要があるのに選任していない場合は適用となります。

さらに、選任していても監督署に選任報告を提出していない場合は

総括安全衛生管理者については労働安全衛生法100条 労働安全衛生規則第2条第2項

安全管理者については労働安全衛生法100条 労働安全衛生規則第4条第2項(労働安全衛生規則2条第2項を準用)

産業医については労働安全衛生法第100条 労働安全衛生規則第13条第2項(労働安全衛生規則第2条第2



項を準用)

について適用します。(00133 監督官)

●労働安全衛生法第(12条)の適用例

①意識が低い又は合格しないことによる違反の適用

50人以上の事業場は、衛生管理者の選任をおおむね知っているが、非工業的業種だと、選任するという意識が低い事業場もある。受験させても合格者を出すことができない事業場も少なからずある。

②人事異動による未選任違反の適用

スーパーのように、県内に100件近い店舗があると、人事異動により有資格者が異動してしまい、一部の店舗において変更がされていないか、有資格者が店舗にいなくなってしまうことがある。

③事務所には10人前後しか労働者がいない派遣元事業場への違反の適用

派遣業は、派遣元事業場に監督に行っても事業所には10人未満の労働者しかおらず、派遣先に葉落ちしている労働者を含めると50人以上になるということで、選任しなければならないという法解釈ではあるが、事業者は選任しなければならない意識が希薄である。(00107 監督官)

●労働安全衛生法第(12条)の適用例

常時50人以上の労働者を使用しているにもかかわらず、衛生管理者を選任していなかったもの。(00055 監督官)

●労働安全衛生法第(12条)の適用例

- ・衛生管理者が選任されていない。
- ・非常に多く適用される条文です。(00027 監督官)

●労働安全衛生法第(13条)の適用例

産業医が選任されていない。

- ・衛生管理者・産業医の未選任は非常に良くセットで使われる条文です。(00027 監督官)

●労働安全衛生法第(13条)の適用例

産業医の未選任違反の適用

産業医活動を行っている産業医が充足されておらず、事業場も探しているが紹介を受けられないため、選任されていない。(00107 監督官)

●労働安全衛生法第(14条)の適用例

作業主任者未選任や掲示等による氏名・職務周知義務違反での適用が多い。(00107 監督官)

●労働安全衛生法第(17条)の適用例

委員として有資格者である安全管理者が存在しないことから、第2項に規定する委員構成となっていないことから、法第11条の安全管理者不選任の違反とは別に、法第17条の安全委員会を設けていないとして違反指摘をしている。(00076 監督官)

●労働安全衛生法第(18条)の適用例

労働者が常時50人以上いるにもかかわらず、衛生委員会を設置しておらず当該条文に抵触したもの。(00089 監督官)

### ●労働安全衛生法第(18)条の適用例

衛生委員会が開催されていない。

・12条・13条で管理者が選任されていないこととセットで、または、選任されていても衛生委員会が開催されていないことは多いため、よく使われる。(00027 監督官)

### ●労働安全衛生法第(17、18条)の適用例

第2項 安全(衛生)委員会の委員について、安全(衛生)管理者を委員に指名していなかったもの。

第4項 安全委員会の委員について、安全(衛生)管理者のうちから事業者が指名したもの及び当該事業者の労働者で、安全(衛生)管理者のうちから事業者が指名したもの及び当該事業者の労働者で、安全(衛生)に関して経験を有する者のうちから事業者が指名したものの内の半数について、過半数組合または労働者代表の推薦させることなく指名していたもの。(00007 監督官)

### ●労働安全衛生法第(29)条の適用例

この条文は主として建設業(製造業も適用あり)の下請が法違反をした場合に、各条文を適用するにあたり、併せて元請事業場にもこの条文を適用します。

建設業の場合に下請が違反をしないように、元請が指導し、違反があれば是正させる義務を負わせています。下請違反があればセットで元請にもれなくこの条文を適用することになります。(000133 監督官)

### ●労働安全衛生法第(30)条第(2)項の適用例

◎(前段) いわゆる大型マンションの工事で、施主が①建物のみの発注、②外構(駐車場や造園、排水)工事のみの発注、③配管、設備工事(エアコンや電気、ガス、水道)の発注とそれぞれの工事内容毎に分けて、発注書を交わした。同じ敷地内で、同じ時期に近接した場所での作業があるため、労働災害防止を目的として建物を請け負った事業者が、同条1項措置を担当する事業者として指名された。

◎(後段) マンション工事等で、施主が設計事務所にマンション建設を発注した場合に、設計事務所は設計のプロであるが、現場の工事施工についてはノウハウがないため、①建物の建築、②外構工事、③設備工事と、それぞれの業者に発注した。同条1項の措置を担当する事業者として、建物の施工業者が指名された。(00157 監督官または元監督官)

### ●労働安全衛生法第(40)条の適用例

つり上げ荷重3t以上のクレーンについて、性能検査を受検せず、有効期間切れが生じた状態で使用したことについて適用。(00058 監督官)

### ●労働安全衛生法第(41)条2の適用例 ボイラー則第38条40条 違反

昭和52年当時、東京都三鷹市の総合病院で暖房用に使用しているボイラーの有効期間が切れるとのことで相談を受け、急遽有効期限の切れる当日ギリギリに「性能検査」を行う事として出向いたところ、ボイラーが停止されておらず、性能検査ができない状況であり且つ週末に当たることから、指示を行いボイラーの電源をOFFにして、電源BOXの開閉扉に行政機関名の入った「使用停止」のシールを貼り、検査合格までの間ボイラー運転の停止措置を行う命令書を交付した事案。(000283 技官)

### ●労働安全衛生法第(57条)の適用例

有害物質に係る安全データシート等の通知文書が備え付けられていない事業場が中には認められるところであるが、その原因として、事業主の法律の不知などによるほか、提供者から事業場に対して同通知文書が交付さ

れていないことが一因であるときも認められる。(00074 監督官)

●労働安全衛生法第(61)条の適用例

機体重量 3 トン以上の車両系建設機械に車両系建設機械運転技能講習を修了していない、下請会社の代表取締役が土木作業現場で運転していたため安衛法第 62 条第 2 項違反を同社に対して勧告した。

安衛法第 59 条は、危険・有害業務に対する労働者への特別教育の実施を定めているため違反行為の客体は、労働者に限られるが、安衛法第 61 条の場合は違反行為の客体について同条 1 項は労働者に対して、同条 2 項は労働者以外の事業主や一人親方についても違反が成立する。(00035 監督官)

●労働安全衛生法第(65 条)の適用例

有機溶剤業務等、一定の有害業務については作業環境測定士による作業環境測定を実施しなければならないところ、その頻度は 6 か月に 1 回であり、当該測定のための費用の負担が、経営上厳しいと申し立てる事業場がみられる。(00074 監督官)

●主に労働安全衛生法第(66)条に紐付く(安全衛生)規則第(44)条の適用例

使用する労働者に対し、1 年以内に 1 回、定期健康診断を受診させていないもの。(00055 監督官)

●労働安全衛生法第(78) 条の適用例

特定指定事業場に対する改善計画の提出。(00167 監督官)

●労働安全衛生法第(79)条の適用例

食料品の製造を行う事業場において、短期間で立て続けに休業災害が発生し、また、当該事業場における災害の度数率が同業種よりも高い水準にある等安全対策の取組み状況に問題が認められたことから、当該事業場に対して安全に関する改善計画を作成するよう指示したもの。(00155 不明)

●労働安全衛生法第(101) 条の適用例

S D S の周知方法(00167 監督官)

●労働安全衛生法第(101)条の適用例

製造業を営む事業場において、労働安全衛生法や労働安全衛生規則等の要旨が関係労働者に対して周知されていなかったことから、当該事業場で行われる作業に関連した法令等の部分を抜粋して掲示等するよう指導したもの。(00155 不明)

●労働安全衛生法第(103) 条の適用例

エチルベンゼンを取り扱う作業場において、常時作業に従事する労働者について、1 月を超えない期間ごとに法令で定める事項を記録していなかったもの。特別管理物質については作業の記録と 30 年間の保存が義務づけられているが、新たに特別管理物質として追加される物質が増えており、安衛法第 103 条の適用例が増えている。(00206 監督官)

●主に労働安全衛生法第 (103) 条に紐付く (労働安全衛生) 規則第 (38) 条の適用例

事業者が自ら行った特別教育の記録が保管されておらず、特別教育を必要とする業務に就く労働者に対して当該特別教育が実施されているか否かが明らかでなかったことから、特別教育の実施時には安衛則で定める事項を記録及び保存するよう指導したもの

(00155 不明)

●主に労働安全衛生法第(103)条に紐付く(安衛)規則第(51)条の適用例

定期健康診断実施後、事業場において当該健診結果の個人票を保存していないことが判明し、本条文を適用した。(00130 監督官・技官)

●労働安全衛生法第(120)条の適用例

臨検拒否に対する罰条の適用。(00167 監督官)

●労働安全衛生法第(122)条の適用例

両罰規定。(00163 監督官)

●労働安全衛生法第(122)条の適用例

法人の代表者等が、労働安全衛生法に違反し、同法に基づき罰則の適用を受けた場合において、同違反が業務に関して生じた違反行為であったことから、当該法人に対しても罰金刑が課された。このような実行行為者と法人の両罰を規定しているのは、労働安全衛生法の性格によくあわすものと言える。(労働基準法も同様)。(00147 監督官)

●労働安全衛生法第(122)条の適用例

労働安全衛生法第 59 条第 3 項により、事業者は、一定の危険有害業務に労働者をつかせるとき、特別の教育を行わなければならない。ここでいう「事業者」とは、法人企業であれば当該法人、個人企業であれば事業経営主を指す。建設現場の現場代理人の指示により、労働安全衛生法 59 条第 3 項の特別教育を行っていない労働者を、当該特別教育が必要な業務につかせた場合、法第 119 条第 1 号の規定に罰則があるが、法第 122 条の規定により、法人又は事業経営主とともに実行行為者である現場代理人も処罰の対象となる。(00082 監督官)

●労働安全衛生法に基づくストレスチェック制度実施マニュアル(00059 技官)

【2-省令関係】

●主に労働安全衛生法第(12)条に紐づく(労働安全衛生)規制第(7)条の適用例

未選任及び規模による衛生管理者選任数の不足。(00107 監督官)

●主に労働安全衛生法第(12)条に紐づく(労働安全衛生)規制第(4)条及び(労働安全衛生)規制第(7)条の適用例、主に労働安全衛生法第(13)条に紐づく(労働安全衛生)規制第(5)条及び(労働安全衛生)規制第(13)条の適用例、主に労働安全衛生法第(18)条に紐づく(労働安全衛生)規制第(9)条の適用例

(1)事案概要

A株式会社は、常時 50 人以上の労働者を使用し、△△業を営む事業者であるが、

1 平成○年○月○日に常時 50 人以上の労働者を使用していたのであるから少なくとも

同日 14 日以内に第一種衛生管理者免許若しくは衛生工学衛生管理者免許を有する者ほか法令の定める資格を有する者のうちから衛生管理者を選任しなけりばならなかつたのに、これを怠り、以て、平成○年○月○日から平成●年●月●日に至るまで産業医を選任しなかつたものである。

2 平成○年○月○日に常時 50 人以上の労働者を使用していたのであるから、少なくとも同日から 14 日以内に法令で定める要件を備えた医師のうちから産業医を選任しなけりばならなかつたのに、これを怠り、以て、平成○年○月○日から平成●年●月●日に至るまで産業医を選任しなかつたものである。



3 平成○年○月○日に常時 50 人以上の労働者を使用していたのであるから、労働者の健康障害を防止するための基本となるべき対策に関する事、その他法令で定める事項を調査審議させ、事業者に対して意見を述べさせるための衛生委員会を設けなければならなかったのに、これを怠り、以て平成○年○月から平成●年●月●日に至るまで衛生委員会を設けなかったものである。

#### (2)常時使用労働者数の特定

平成○年○月○日から平成●年●月●日に至るまでの間、常時 50 人以上の労働者を使用していたことを確認する方法が問題となった。常時使用労働者数の特定の方法として、①タイムカードや出勤簿などを基に日単位②賃金台帳などを基に月単位、または③源泉徴収票などを基に年単位の労働者数から把握する方法も考えられた。

結局、最も厳格に考えて、タイムカードから、平成○年○月○日から平成●年●月●日までの間の日ごとの実際の出勤労働者数を把握し、日々の出勤者数が 50 人を超えていることをもって、常時 50 人以上の労働者を使用していたと判断した。(00063 監督官)

#### ●主に労働安全衛生法第(13)条に紐づく(労働安全衛生)規制第(13)条の適用例

##### 産業医の未選任

50 人以上の事業場であれば、法違反になるからという理由だけではなく、実際に産業医を選任して活動してほしいという意識は以前に比べて高くなっていると思われる。(以前は、名ばかり産業医というものもあったと思う)

現在、里道では産業医数が充足していないこともあり、産業医が選任できない事業場もあることから、安衛則 15 条の 2(50 人未満の事業場に対する努力義務)にあるよう保健師の代替が可能な省令改正はできないものかと思う。(医師会が反対すると思われるが)(00107 監督官)

#### ●主に労働安全衛生法第(14)条に紐づく(労働安全衛生規則)規則第(18)条の適用例

作業主任者の周知について、作業場が複数離れた箇所にあるにもかかわらず、作業場所ごとに周知の掲示をしていなかったことから当該条文に抵触をしたもの。(00089 監督官)

#### ●主に労働安全衛生法第(14)条に紐づく(労働安全衛生)規制第(18)条の適用例

##### 建設現場における足場・型枠などの作業主任者の氏名等周知義務違反(00107 監督官)

#### ●主に労働安全衛生法第(14)条に紐づく(労働安全衛生)規制第(133)条の適用例(司法)

A 社プレス工場プレスにおいて、同社の労働者がプレスの金型の交換部品を下型に置いた状態でプレス機を作動させたため、その金型の交換部分が砕け飛び、破片が同労働者の首に当たり、失血のため死亡した。A 社代表取締役は「動力により駆動されるプレス機械を 5 台以上有する事業場において行う当該機械による作業」があるにもかかわらず、プレス機械作業主任者を選任していなかった。(00053 監督官)

#### ●主に労働安全衛生法第(14)条に紐づく(労働安全衛生)規制第(566)条の適用例

##### 足場作業主任者の職務義務違反(00107 監督官)

#### ●主に労働安全衛生法第(18)条に紐づく(労働安全衛生)規制第(23)条の適用例

安全衛生委員会については毎月開催の必要があるところ、審議事項の話題がなくなったなどを理由に、内容が形骸化していたり、毎月の開催がなくなったりする事業場があるほか、産業医など委員会の構成員が揃っていない月が多く事業場も認められるところである。

審議事項については法律で示されているものの、上記のような事業場においては、委員会の具体的な運用(法

定の審議事項をどのような方法・基準で審議するか) について並んでいる場合がある。(00074 監督官)

●主に労働安全衛生法第(19)条に紐付く(安衛)規則第(23)条の適用例

安全衛生委員会を毎月一回以上開催していない事案について適用。(00058 監督官)

●主に労働安全衛生法第(20)条に紐づく(労働安全衛生)規制第(28)条の適用例

精肉店において、客の注文に応じてミンチ機で挽肉加工する際、安全カバー(プロテクター)の無い状態で加工作業を行い、ロールに巻き込まれ腕を切断した。(00160 技官)

2 ラベル表示・SDS 交付対象物質のリスクアセスメント後の措置が不十分であること等による災害事例(労働安全衛生規則の 577 条(発散抑制)、593 条(呼吸用保護具等))

発生月	概要	程度
平成 29 年 11 月	鋳物製造工程において、中子を作る際に中子から木型が剥がれやすくするため、ノルマルヘプタンを主成分とする薬剤を木型の内部に入って塗布する作業を行っていたところ、急性中毒・意識消失となったもの。本作業についてリスクアセスメントは実施していたが、有機溶剤中毒予防規則等の特別規則の対象外であるとして、特段のばく露防止対策を実施していなかった。	休業 1 日 (1 名)

(00224 元技官)

●主に労働安全衛生法第(20)条に紐付く(労働安全衛生)規則第(123)条の適用例

木材加工製品を製造する工場において、木材加工用丸のこ盤を使用して作業するに際し、木材加工用丸のこ盤の歯に接触予防装置を設置していなかったもの。

当該丸のこ盤を通常使用している労働者が作業を終え、丸のこ盤を停止させず、歯の回転を停止させないまま、その場を離れたところ、そこに、日頃は工場にはあまり立ち入らない事務員が通りかかり、偶々、躓いた拍子に当該事務員が回転する歯に接触し、死亡した。

安全衛生規則第 123 条は、「木材加工用丸のこ盤(製材用丸のこ盤及び自動送り装置を有する丸のこ盤を除く)には、歯の接触予防装置を設けなければならない」旨規定されており、本事案においては、製材用等の除外規定に該当せず、同条文違反が適用されたもの。

本件災害の直接原因は「歯の接触予防装置を設けていないこと」であるが、間接原因としては「作業者が丸のこ盤を回転させた状態で作業箇所を離れた」ことも挙げられる。もし、接触予防装置が設けられていたとしても、作業者がいない状況下で丸のこ盤が可動している場所に、他の労働者が立ち上がった場合には、予測できない状態が現出することも予想される。そう考えると、間接原因に関する再発防止対策から、同 123 条に限らず、101 条以下の第 1 節「一般基準」の何処かに、「機械が可動している場合には、作業者は当該箇所を離れることを禁ずる」旨の明文規定の挿入を検討すべきと考える。(000248 元監督官)

●主に労働安全衛生法第(20)条に紐付く(労働安全衛生)規則第(349)条の適用例

電化製品量販店が、一般家庭より依頼された当該家屋の屋根上へのテレビ電波受信用アンテナの設置工事を社員に指示。当該家屋の上空約 7 メートルには、7 万 7 0 0 0 ボルトの特別高圧電線が架設されており、この特別高圧電線は、当該地域一帯に一般民家が建築される以前から架設されていたものであった。

指示された社員は、一人で現場に赴き、長さ5メートルの金属製のアンテナポールを持ち、高さ4.5メートルの屋根上に上り、設置作業を始めたが、間もなく、社員が両手で保持していたアンテナポールが特別高圧電線に接触。社員は感電し即死したものの。

労働安全衛生法第20条を根拠とする安全衛生規則第349条では、「架設電線等に近接する場所での工作物の建設等の作業を行う場合で、身体等が接触、接近することによる感電の危険が生ずる恐れがある場合には、①電路の移設。②危険防止の囲いの設置。③電路への絶縁用防護具の装着を行うことのいずれかの措置を講じることとし、この3つの措置が著しく困難なときは「監視人を置き、作業を監視させること」と規定されており、本事案は同条が適用となるものである。

本事案は、7万7000ボルトの特別高圧電線であり、①②③の措置は著しく困難なものであり、監視人を置き作業を監視させなければならないところ、その措置を怠っていたものであり、同条文違反が認められると判断されたもの。

違反事項としては、上記のとおりであるが、本件において安全衛生規則第349条に定める「監視人を置き、作業を監視させること」を実施すれば本件災害を防ぐことが出来たのか、との疑問が残る。その観点から検討するに、上空7メートルに特別高圧電線が架かる家屋の高さ4.5メートルの屋根上に上り、長さ5メートルの金属製ポールを持ち、その設置作業を行う状況下で、作業者とは別に監視人を置き作業を監視させたとしても、屋根上から高さ2.5メートルの位置に特別高圧電線が架けられている訳であるから、その位置で長さ5メートルの金属製ポールを両手で保持して作業を行った場合、誘導電流の発生が無かったとしても、金属製ポールが特別高圧電線に接触する蓋然性は極めて高く、それを監視人からの指示により防ぐことは、極めて困難であると言わざるを得ない。

そう考えた時、同規則349条が言う「監視人を置けば、措置を講じなくても良い」との規定を削除し、当該場所での各種措置が困難な場合には作業を禁止することとする以外に、同種災害の防止は難しいものと思われる。(000248 元監督官)

#### ●労働安全衛生法第(21)条に紐付く労働安全衛生規則第(266)条の適用例

製鉄事業場において、石炭塔ホッパーにDAPS炭と呼ばれる乾燥炭を貯めていたところ、自然発火し、発熱を解消しようと作業を行っていたが、爆発火災が発生し、付近で作業していた15名が熱傷し負傷したものの。(000157 監督官または元監督官)

#### ●労働安全衛生法第(22)条に紐付く高気圧作業安全衛生規則第(37)条の適用例

海上交通の事業場において、自社が所有する船舶のプロペラ修理のために、水中眼鏡と潜水スーツ、アクアラングのみを着用して海中に入ったが、いつまでも浮上してこないため捜索したところ、海底に沈んでいるところを発見された。水中時計、水深計、及び鋭利な刃物を携行させるほか、救命胴衣又は浮力調整具を着用させていなかった。(000157 監督官または元監督官)

#### ●主に労働安全衛生法第(22)条に紐付く(安衛)規則第(577、593)条の適用例

「職場における化学物質等の管理のあり方に関する検討会」資料  
特別規則対象外物質による典型的な災害事例

#### ●主に労働安全衛生法第(45)条に紐付く(クレーン等安全)規則第(34)条の適用例

クレーン設置後年1回の自主検査について、定期自主検査指針に基づいて検査を実施していなかったため当該条文に抵触をしたもの。(00089 監督官)

#### ●主に労働安全衛生法第(45)条に紐付く(安衛)規則第(151、21)条の適用例

フォークリフトについて、1年を超えない期間ごとに1回、定期自主検査を実施していない。

・法45条に基づく各種の定期自主検査は、よく適用する項目となる。

大企業ではほとんど違反はないが、町工場などでは忘れられていることもよくある。(00027 監督官)

●主に労働安全衛生法第(45)条に紐づく(安全衛生)規制第(151)の(21)条の適用例

フォークリフトについて、1年以内ごとに1回、定期的に(特定)自主検査を行っていないこと。(00054 監督官)

●主に労働安全衛生法第(57)条に2の適齢例

有害物質に係る安全データシート等の通知文書が備え付けられていない事業場が備え付けられていない事業場の中には認められるところであるが、その原因として、事業主の法律の不知などによるほか、提供者から事業場に対して同通知文書が国府されていないことが一因であるときも認められる。(00074 監督官)

●主に労働安全衛生法第(57)条に3に紐づく(労働安全衛生)規制第(34)条の2の7の適用例

化学物質リスクアセスメントの実施義務を規定した本条については、施行されてから日が浅く、化学物質を取り扱っているにもかかわらず未実施である事業場もみられるところである。

そのような事業場では、リスクアセスメントの実施方法について理解が不足しており、その運用方法に悩みを持つこともあるため、安全データシートの周知促進に合わせて、コントロールバンディング等簡易に化学物質リスクアセスメントが実施可能な方法の周知も行う必要がある。(00074 監督官)

●労働安全衛生法第(61)条に紐づく労働安全衛生法施行令第(20)条16号の適用例

被疑会社は、精錬事業を営む事業者、被疑者は、被疑会社の取締役として実質的経営者であるが、被疑者は被疑会社の業務に関し、被疑会社の労働者2名に、電解槽に入れる予定の板をプレスでまっすぐに矯正する作業を行わせるにあたり、法令の定める玉掛け業務の資格がない労働者2名をつり上げ荷重2・8トンの天井クレーンの玉掛けの業務に就かせたものである。(00166 監督官)

●主に労働安全衛生法第(66)条の8の3に紐づく(安衛)規則第(52)条の7の3の適用例

・タイムカード等客観的な方法で労働時間の状況を把握していない。

・本来は労働基準法に設けられる規制だと思うが、健康管理という面から安衛法に設けられた規制となっている。

労働基準法32条などとセットでよく適用される。

(00027 監督官)

●主に労働安全衛生法第(66)条8の3に紐づく(安全衛生)規制第(52)条の7の3の適用例

労働時間を把握していない。(00005 監督官)

●主に労働安全衛生法第(66)条8の3に紐づく(労働安全衛生)規制第(52)条の7の3の適用例

労働者の出勤(欠勤)状況を出勤簿に押印させることによって把握しているのみで、始業時刻、終業時刻、各日の時間外労働時間数などを把握することなく、タイムカードによる記録、パーソナルコンピューター等の電子計算機の使用時間の記録等の客観的な方法その他の適切な方法により労働時間を把握しているとは認められなかった。(00007 監督官)

●主に労働安全衛生法第(100)条に紐づく(労働安全衛生)規則第(95)条の6の適用例

厚生労働大臣が定める物質を取り扱っている事業場で、当該物質を500キログラム以上取り扱っている場合



は、1年間の取扱量を翌年の1月1日から3月31日までに有害物ばく露報告を所轄の労働基準監督署長に報告していなかったもの。

労働安全衛生法100条に紐付く省令は、その報告期限として概ね「速やかに」「遅滞なく」「あらかじめ」など期限の目安を示しているが、労働安全衛生規則第95条の6で定める有害物ばく露報告の報告期限は、厚生労働省告示で示されている。(00035 監督官)

●主に労働安全衛生法第(100)条に紐づく(安全衛生)規制第(96)条の適用例  
研削といし破裂による事故報告書未提出。(00160 技官)

●主に労働安全衛生法第(101)条に紐づく(安全衛生)規制第(98)条の(2、第1項)の適用例  
SDSの周知方法(00167 監督官)

●主に労働安全衛生法第(103)条に紐づく(安全衛生)規制第(98)条の(135)条の(2)項の適用例  
プレス自主検査の3年間保存。(00167 監督官)

●主に労働安全衛生法第(103)条に紐づく(労働安全衛生)規則第(23)条の適用例

ある企業の労働組合役員より「自分は当社の衛生委員会の委員であるが、毎月1回の衛生委員会に産業医が出席してこないことが多い。産業医を強制的に出席させる手段はないのか？ 産業医が出席しないと衛生委員会が成立しないというような法律の規定はないのか」との質問が寄せられた。

当該質問に対しては、次のように回答したもの。

「産業医は事業場の「産業保健の中心的役割を担っているもの」であり、安衛法14条の関連する産業医の職務に関する通達でも「衛生委員会等に出席して医学的見地から意見を述べること」などが求められている。但し、強制的に出席しなければならないというような規程はない。ご質問の衛生委員会の開催要件の規定は、23条第2項の「衛生委員会の運営について定める事項」に該当するものであり、委員会が定めるものである。よって、委員会の規定に「開催要件の一つ産業医の出席」を加えることになれば、その出席への強い後押しにはなると思われるので、労使双方の委員で協議されては如何か」。

衛生委員会の充実に関して、平18.2.24基発第0224003号において、衛生委員会における医学的、専門的見地からの意見の重要性に鑑み、「産業医や衛生管理者について、その適正な選任はもとより、衛生委員会等への出席の徹底を図り、その役割が適切に果たされる必要があること」と示されている。すなわち、衛生委員会への産業医の出席については、法による規制ではなく、衛生委員会を主宰する当該事業場の自主性に委ねる方策を選択したものである。これにより、産業医の衛生委員会への関わり、引いては当該事業場の安全衛生水準の向上に繋がれば、法の意図した大きな成果と言えるものと思われる。

しかしながら、前述のように衛生委員会に出席しない産業医が一定数存在するのであれば、産業医への法的規制も考慮する必要があるとの意見が出てくることも想定される。

これに対しては、何らかの調査の実施により、実態把握を行い、事前に方向性を決めておく必要があるのではないだろうか。(000248 元監督官)

### 質問3

7、12、20(00074 監督官)

1、2、19(00054 監督官)

1、2、14※1、2に関して司法・監督時には悩むケースが多い。(00081 監督官)

- 1、15、17(00077 監督官)
- 2、6、12(00161 技官)
- 2、8、12(00204 監督官)
- 4、9、17(00222 元監督官・元技官)
- 1、2、4(00122 監督官)
- 1、2、14(00256 元監督官)
- 1、2、18(00163 監督官)
- 2、11、15(00286 技官)
- 2、17(00078 監督官)
- 2、7、8 (00005 監督官)
- 1、2、18(00275 元監督官)
- 4、5、6(00223 技官)
- 1、3、9 (00259 監督官)
- 1、7、15 (00287 元監督官)
- 7、13、14(00264 元監督官)
- 1、8、14 (00035 監督官)
- 2、6、12(00167 監督官)
- 1、2、14(00112 技官)
- 1、4、16(00160 技官)
- 4、6、14(00053 監督官)
- 2、19(00177 監督官)
- 2、7、8(00007 監督官)
- 4、8、17(00147 監督官)
- 2、12、14(00063 監督官)
- 2、7、14 (00087 監督官)
- 2、18、19 (00107 監督官)
- 1、2、8 (00212 監督官)
- 2、13、20 (00072 監督官)
- 5、6、14(00024 監督官)
- 4、8、17(00268 元監督官)
- 2、7、14(00059 技官)
- 1、2、18(00186 監督官)
- 1、2、8(00040 監督官)
- 7、14、17(00017 記載なし)
- 7、12、17(00184 技官)
- 5、7、17(00240 元監督官)
- 2、12、15(00113 技官)
- 2、3、14(00132 監督官)
- 2、5、15(00141 技官)
- 1、2、8(00142 技官)
- 3、7、16(000217 元監督官)
- 2、9、12 「常時性」については、有機則や特化則に「臨時の作業」についての解釈があることから、その裏返し  
しが常時行われる作業、すなわち作業工程の中でサイクル的に実施される作業と理解できますが、その頻度に

ついて、些かの疑義があることも事実です。(000283 技官)

1、2、14(000248 元監督官)

2、8、12(000127 監督官)

1、5、8(番号なし 監督官)

2、7、16(000236 元監督官)

1、2、4(000157 監督官または元監督官)

2、6、17(000057 監督官)

1、2、19(000155 不明)

2、7(00130 監督官・技官)

2、8、12(00058 監督官)

1、2、15(00027 監督官)

1、2、3(00174 監督官)

2、8、12(00228 元技官)

2、7、14(00055 監督官)

2、4、8(00121 監督官)

1、2、14、19(00162 監督官)

1、5、7(00185 技官)

4、8、15(00076 監督官)

9、10、12 (00071 監督官)

2、4、5 (00082 監督官)

1、14、17(00088 元監督官)

1、2、18 (00089 監督官)

1、2、6 (00166 監督官)

4、5、6、7、12、15 (00170 不明)

1、2、14 (00173 技官)

2、5、14 (00180 監督官)

1、2、3 (00181 監督官)

5、14、15 (00196 監督官)

1、2、17 (00205 技官)

1、2、5 (00206 監督官)

2、8、11 (00224 元技官)

#### (その他)

●特に特別有機溶剤など近年の法改正の条文についてであるが、複雑・難解な表現が多く、内容の理解が難しいものがあるので、万人が法の趣旨を理解できるような内容を目指すべきかと思料する。(00074 監督官)

●当然、法の適用を受け、規制しなければならないが、(災害の頻度が高いとか、同種の災害の範疇でありながら、適用されないケース) 条文中で示されている例示に記されていないなかったり、少しの文章表現で違反認定ができなかったりする。また、意図的に構成要件を外すことによって法の適用から逃れたりするケースを洗い出し、対処した方がよいものと思料します。(00081 監督官)

●労働安全衛生法を刑罰法規として適用することを念頭にした各法条文の規制内容の明確化。(00078 監督官)

●①については RA の概念(許容できないリスク)と共通化。(00160 技官)

●簡易な法体系にすること。理由：現在の複雑な法令体系は、罪刑法定主義の観点から問題があると思料する。また、労働法令は、保護対象となる労働省(未熟練、若年、外国人)が読んで理解できる内容にすべき。(00177 監督官)

●就業構造が変化する中、第三次産業の占める割合が多くなっているが、一方で、労働安全衛生法例は、第一次・第二次産業を主たるターゲットとしている印象があるものである。第三次産業に対する実効的な対策等について、議論をいただきたい。(00147 監督官)

●安衛法で規定された各種資格について、事業者が自社の労働者について、有資格者かどうかを確認する義務。今の法体系では、有資格者かどうか、確認していないので知らなかったといわれてしまえば、処罰できないことがある。(00107 監督官)

●活用されていない制度の活性化を図る方策を検討すべき(たとえば法第 99 条の 2、第 99 条の 3。法改正により折角導入された制度にも拘らず、運用されたのは法改正後ごく僅かの期間のみ。現在は全く実績がない模様)。(00268 元監督官)

●労働基準法、労働安全衛生法は、学校教育法の中では詳しく教育していない。中学、高校の段階で、しっかり教育すべきである。社会に出てからも法令の知識のない者が多い。事業者、労働者に対して最低の知識を教育すべき。(00141 技官)

●(1)労働者の措置義務違反に対する反則通告制度の導入。

(理由)

無資格作業や保護具の未使用については、事業者だけでなく、無資格作業や保護具未使用であった者(労働者)への厳格な法適用が必要と考えられるところ、現状、当該違反については、させた(させなかった)側の事業者を法違反として送致することはともかく、やった(しなかった)労働者をその義務違反で送致しているのは限定的である。やらされたといえども労働者は紛れもなく法違反の実行行為者であるのにもかかわらず、「やらされた=被害者」のようになってしまっているのではないだろうか。

交通違反の反則通告制度を参考に、監督官の臨検時の資格確認において運転者の資格証の不携帯を現認した場合やマスクの未着用などは当該作業を行う労働者自身にも法違反がある(例えば、臨検時に資格証の不所持ならば運転者に 61②違反か 61③違反がある。マスクは「着用を命じられている」という前提条件はあるが)のだから、交通違反でいうところの「青切符」で反則金の納付をさせてもよいのではないだろうか。

(2)化学物質暴露対策のベースとなる規則の制定(既存の規則の整理・見直しも含む)

(理由)

有機則や特化則等では、化学物質の有害性(急性中毒や発がん性)に着目した規制となっている。

しかし、例えば、特別有機溶剤は発がん性があるものとして特化則で規定されながらその使用方法が有機溶剤と同様であることから有機則を準用していたり、リフトラクトリーセラミックファイバーはもともとその性状から粉じん則の適用を受ける場合があるなかさらに特化則で規定されたり、最近では、「溶接ヒューム」といったものは化学物質名とは言えないものが特化則の適用を受けたりと、垣根がなくなってきているのではないだろうか。

そしてこのような規定方法が、一般人をして極めてわかりにくい内容の法律になっている原因ではないかと思われる。

現在の法規制を受ける物質を変更するということではなく、有機則をみても特化則をみても粉じん則をみても

「局排」や「呼吸用保護具」が規定されているのだからそれらをまとめることができるのではないだろうか。そして、その場合、化学物質の毒性に着目するよりも、性状に伴う利用（作業）方法に着目して規制するほうが、わかりやすいのではないだろうか（「毒性強いからちゃんとやるけど弱いから多少吸っても大丈夫」とはならないと思うのです。極端な話、フッ化水素水溶液とアセトンは液体という点で同じ、溶接ヒュームも粉体である特化物も粉体である点で同じと考えて規制する）。

また、前述したいわば「基本的措置」に加えて対象化学物質ごとに特別にとるべき措置が生じた場合でも、物質ごとの条文を作るのではなく（特化則 38 の○のようなもの）、当該措置もまた「基本的措置」部分に追加（必ず同様の措置を講ずるべき別の物質が出てくると思われる）し、物質ごとにどの基本的措置を講ずる必要があるのかを一覧表形式で明示する等がわかりやすいのではないだろうか。

(00071 監督官)

●司法事件として法令を適用する際、通達、判例等において取り扱われていない条文の解釈に苦慮することがあり、専門家において検討していただきたい。(00082 監督官)

●医師による面接指導の対象となる長時間労働者がダブルワーク、トリプルワークを行っている場合、実施義務のある事業者をどちらとするか、また、各事業者から医師への情報提供のあり方をどうすべきか。(00141 監督官1)

●安衛法・安衛則共に、条文ではなく通達にて解釈され、定義があいまいなのが問題ではないか(00170 不明)

●15については、行政指導（通達）によるものについても検討が望まれます。(00189 技官)

●労基法時代から歴史を積み重ねてきた結果、複雑怪奇な安衛法令です。特定機械や化学物質の専門性分野も含めて、分野別分類をしっかりと区画し、その中で橋渡しをする工夫を行い、一般の労働者(社会人)にも分かり易い、シンプルな法令を目指しましょう(000283 元監督官)

●クラウドワーカー、ギグワーカーなど多様な就労形態が増加していますが、労働基準法の労働者の定義を再構築しないと、労働安全衛生法における法規制のあり方を論じることができないのではないかと考えられます。(000127 監督官)

●特別刑法の側面からの検討に厚みを持たせていただきたいと考えます

同法はその性質上、政省令委任のみならず J I S 等の他基準の援用に加え、累積した膨大な行政通達が一体となって運用されている。他方、このことは、犯罪たる同違反の構成要件の不明瞭化を招いている。同法運用の信頼性確保のためには同法違反と罪刑法定主義との整合性を視野に置いた検討も重要と考える。

参考文献（名称等不明瞭）

寺西 元神戸地検検事正「労働安全衛生法違反の刑事責任」

法務総合研究所「法務研究『労働安全衛生法違反被疑事件の研究』」(000236 元監督官)

●別紙の「労働安全衛生法の問題（メモ）.docx」（別途資料内）に記載いたしました。(番号なし 監督官)

●化学物質規制の局所排気装置の設置に関し、多くの事業場が対応に苦勞しているいくつかのケースに関し、具体的改善策を提示すること。（例：資金力が乏しい小規模事業場の屋内作業場において、床面の広範囲に渡り、金属部材を並べ、第2種有機溶剤を用いて吹き付け塗装を行う場合(000157 監督官または元監督官)



●安衛法第 30 条、第 30 条の 3、第 31 条、第 31 条の 3、第 32 条において「注文者」「発注者」「特定元方事業者」「請負人」の各々の負うべき責について、現状より明確に解される文言で表れるべきと史料します。(00130 監督官・技官)

- ・政令・省令とその法の根拠条文の敵否（法に根拠のない省令の扱いを含む）
- ・行政指導、司法書士の双方に安衛関係法令を適用する現状の敵否
- ・使用停止等処分の他に営業停止処分等新たな行政処分を設けることの敵否（00181 監督官）

#### 質問 4

##### ●(1)一測足場の墜落防止措置等

一測足場についてはその構造上、作業床の片側（建地のない側）は手すり等の墜落防止措置が講じられないものであり、本足場が安全衛生の観点から優先して設置されるべきところ、本足場を設置することが可能なだけのスペースがあるにもかかわらず、より簡易な一側足場を設置し、墜落の危険のある足場で労働者が作業している状況も認められることから、一測足場の設置の基準等について、一定の考慮が必要ではないかと思料する。

##### (2)足場の倒壊防止関係

法定の壁つなぎの設置間隔が安全の確保から考慮して適切であるか。多くの現場においては法定の設置間隔は広すぎるとして、法定の設置間隔より狭く、法定よりも安全側な間隔で設置している。また、控えの設置についてもより詳細を検討すべきではないかと思料する。(00074 監督官)

●(1)事業者らの目的が、労働者の安全と健康の確保よりも、本法に違反しないことが目的となってしまうほど複雑かつ膨大である。(00054 監督官)

●(1)足場について、本足場が法の敵用を受けるが、業者によっては法の適用を逃れるために、場所的な余裕があるのに、一.五(正式な名称ではない)側足場(本足場から柱を一本飛ばして抜く足場)が認められ、違反勧告ができない状況であり、抜け穴をふせぐ改正があってよいものと思料。

(2)現行、保護帽(ヘルメット)について、現行、飛来・落下防止のために着用義務がある。墜落危険がある場合にも、着用義務とした方がよいものと思料。高層住宅の屋上の端で作業している場合、ヘルメット着用してなくても違反が切れない。(その場合、より性能の高い墜落用のヘルメットの着用に一本化したらと思料)

(3)法改正により「安全带」から「要求性能墜落制止器具」という名称が変わったが、とにかく長過ぎて現場の人に説明してもピンとこないようであり、帯ではないが、安全带の名称をそのまま使った方が良かったのでは。また、名称を変えるにしてももっとわかり易い言葉にすべきでは。(00081 監督官)

●(1)フォークリフトなどの特定自主検査の実施期間が 1 年に 1 回となっているが、車の車検と同様実施期間を見直すべきだと思われる。

(2)安衛則第 131 条の適用に関し、プレスブレーキを除外すべきと考える。(00077 監督官)

●(1)省令規制について、発がん性を有する物質は特化則、中毒を生じる物質は有機則、じん肺を生じる物質は粉じん則と、特性に応じて個別の省令を適用してきたが、近年では、発がん性を有する有機溶剤を特化則で規制し、アーク溶接ヒュームを特化則で規制するなど、省令をまたいだ重複(したりしなかったり)する複雑な非常にわかりにくい規則になっている。行政官も理解に苦しんでいるが、法令を守る対象である事業者が理解できないレベルになっており、とても大きな問題になっている。(00161 技官)

●(1)免許試験受験のための学齢、実務経験を廃止すれば、受験機会が拡大されるとともに、電子申請が用意に行えるようになる。なお、免許取得のため、実務経験に伴う能力を求めるのであれば、免許試験合格後に一定の実務経験を求めることも考えられる。(00222 元監督官・元技官)

●(1)一側足場に対する規則の新設。

(2)特化側の条文をわかりやすく読めるように全面的な見直し整理。

(00163 監督官)

●(1)労働安全衛生法を刑罰法規として適用することを念頭にした各法条文の規則内容の明確化(例えば、労働安全衛生規則第 519 条の「囲い、手すり、覆い等」の「当」に該当する措置の明確化、求められる高さの明確化)。

(2)厚生労働省令各条項の根拠となる法条項の明確化(例えば、労働安全衛生規則第 4 条第 2 項、第 18 条、第 23 条)。

(3)散財記載されている用語の意義の集約化(例えば「クレーン」は解釈例規で、「クレーン等」は労働安全衛生規則で、「移動式クレーン」は労働安全衛生法施工令においてそれぞれ定義されている)。(00078 監督官)

●(1)免許、技能講習修了者については、定期的に技能確認のための更新制度を設けるべきである。

(2)安全管理者、衛生管理者については、選任後に定期的に能力向上教育を義務付けるべきである。(00275 元監督官)

●(1)請負制度の更新(00259 監督官)

●(1)労働安全衛生規則第 151 条の 3、第 151 条の 89、第 151 条の 125、第 155 条、第 194 条の 5、第 194 条の 9 等「作業計画」を定め履行すべき旨の条文があり、法 20 条を根拠として取り扱っているが、検察官より根拠となる法条文が無いのではと批判されることがあった。本省令はカバーをつける等ダイレクトな措置でないのも、もっともな見解である。根拠法を明らかにしてほしいところ。(00287 元監督官)

●(1)労働災害の発生状況を見るに、往來型の災害が殆どであります。法的な措置を講じなければ労働災害が発生する恐れがあることは、事業者・実行行為者は十分認識出来ていると思います。このような状況からすれば、死亡や一生寝たきりになるような重篤災害を発生させた場合には、結果的過重犯の対象となるようにしたら如何でしょうか。災害防止への関心・取組が強化されてくると思います。

(2)労働者派遣法の派遣元、派遣先の適用区分の見直し(第 45 条)

労働者派遣法が制定されて久しいが、法施行後の問題点・この法律の功罪を明らかにし、再検討すべきと思います。不安定雇用の温床となっているのではないのでしょうか。それと、現行の第 45 条の法適用区分も。

(3)法令の構成が難しすぎます。

法令順守を求めるのであれば、関係者(事業者、安全衛生担当者、労働者)に分かりやすいものではないといけません。法令の内容を知らない、理解できないものを順守することは難しいと思います。

(4)「常時生」は、条文ごとに解釈を示すべきだと思います。(00264 元監督官)

●(1)建設事業等の特別規制について、対象が限定されている部分、(足場に手摺がない→特別規制手摺設置困難→安全带使用義務→特別規制(元請は責任を負わないので)

(2)3 トン未満のクレーンの過飛散防止装置の全面義務化。(既設クレーンへの安全装置後付け)(転倒事故等が多いので)

(3)労災かくし事業の厳罰化、罰則の強化。(単 23 号未提出等の事業を除き、悪質性の高いもの)(00167 監督官)

●(1)より一層の簡略化(有機則と特化則の統合。エレベーター&リフトの国交省への一本化等。(00160 技官)

●(1)労働者私傷病報告の提出義務の精緻化。

(2)欧米に比べて、細やかすぎる法体系。

(3)日本の司法全体であるが高額の懲罰的な損害賠償生徒の認容。(行政罰も)(00177 監督官)

●(1)各種条文における「常時」について

用語を定義するか、別の表現とすべきではないか。

(理由)法の周知における「常時」(法 101 条)、安全衛生管理体制等における「常時」(安衛令 2 条ほか)、有害業務に従事する場合の「常時」(法 101 条)、安全衛生管理体制等における「常時」(じん肺法 6 条、有機則 29 条ほか)、定格荷重や警報装置等にかかる「常時」(則 389 条の 9、クレーン則 24 条の 2 ほか)で意味が異なることが明らかと考えられ、誰が読んでも同じ意味に解される保証がないことは不適切と考えられることから。

(2)労働安全衛生規則第 97 条

「遅滞なく」を例えば、発生時から 1 カ月以内など特定の期間とすべきではないか(理由)労災が発生した事実を隠す等の意図で報告を遅らせる場合を想定すると、期日を設定した方が、取り締まりが容易であり、また、取り締まりの規定としては、期日があいまいであることは不適切と考えられることか。

(3)技能講習制度

免許については、都道府県労働局長が行うことから、その実施状況について容易に把握できるが、技能講習については、登録講習機関が実施するものであることから、監督機関において、その実施状況を把握することは困難であるところ、これを把握できる制度にできないか。

(理由)技能講習の修了証を携帯しておらず確認ができない場合に、技能講習を修了していないために携帯していないのか、技能講習を修了していて、紛失等したものか判断することが極めて困難であることから。(00007 監督官)

●(1)罰則の強化

労働安全衛生法違反は、人の生命に関わるケースも多い、現状として、同法第 119 条または 120 条による罰則の適用をされるケースが多く、同条では徴役または罰金が予定されているものの、実際は数十万円の罰金の適用が主であり、同法違反による法益侵害の程度に対して適用される罰則の程度が軽度である印象がある。

(2)過失犯の創設

労働安全衛生法違反にかかる刑事罰はすべて故意犯によるものであるが、過失犯の概念を創設することで、事業者に対して安全衛生に対する意識を高めることや、法違反に対する捜査の迅速化といった効果が得られるとも考えられるので、改正が必要とまではいわないが、検討の余地があるのではないか。(00147 監督官)

●(1)規制される化学物質が増えるたびに改正されている有機溶剤中毒予防規則及び特定化学物質障害予防規則の構成が複雑になってきているように思います。罰則もあるため、規制を受ける側である事業者の目線に立った整理を行う必要があると思います。(00063 監督官)

●(1)事業者が就業制限のかかる業務についての資格の確認義務。

(2)常時性の例示。(00107 監督官)

●(1)労働基準法においては、第 102 条において「国及び公共団体についての適用」の条文があり、適用安易が明確であるが、労働安全衛生法においてはそれに該当する条文がないので、該当する条文を新設すべきと思量



される。(00212 監督官)

### ●(1)法 61 条の就業制限業務に就くことができる資格の見直しの検討

ボイラー溶接士のように、その資格である免許に有効期限があり、免許の有効期限を更新するための定期的知識・技能がチェックされる業務がある一方、フォークリフト運転業務のように、その資格(フォークリフト運転技能講習の修了)をいったん取得すれば終生資格として有効なものもある。

法定時は各業務の危険・有害度や要求される知識・技能レベルに応じてランク分けされ、資格の有効期限が決まっていたものと思われるが、その後災害事例の情報も蓄積されていると思われるから、必要に応じて見直しを図ったらどうであろうか。

なお、危険有害業務従事者への教育についての法 60 条の 2 による事業者の努力義務との関係には注意する必要がある。

また、当然であるが、事業者に新たな負担を課すことにつながる規制ゆえに、広く必要性が認識され機が熟したときでないと法令改正に向かうエネルギーは生まれえないため、本意見はそのような環境が築かれたことを前提としてのものである。

厚生労働省の運営する「職場のあんぜんサイト」に掲載されている労働災害事例のデータベースはよくまとまっており、事例も数多く紹介されている。災害原因や再発防止対策の詳細も記述されていて、提供される像法は信頼できるものである。そこでその内容を見ると、終業制限業務における災害に関しては、「就業制限業務の従事者が無資格であった」旨を単に災害原因不足として認定しているものが非常に多い反面、当該業務の従事者の安全衛生に関わる知識・技能不足やそのレベルを記述しているものは僅かしかない。行政のサイトなので、情報源は労働局や労働基準監督署の労働災害調査結果に基づいているものと推測されるところであるが、労働基準監督署等の機関による就業制限業務に係る労働災害の第一次調査の報告書の大部分が知識・技能を充分検証することなく、たとえば「無資格下での災害は無資格であることが直接原因」などと短絡的に原因を特定しすぎているのではないかと疑念がどうしても生じてしまう。労働書は死亡等重大な労働災害については、直接原因につながる法違反を特定し、直ちに事業者への刑事責任追及も行うことになるので、調査に当たって法違反の有無は極めて重要な調査項目になることは理解できる。しかしながら、法令違反がない場合の原因調査は適正に行われているのであろうか。

有資格者が法令の違反を伴わずに作業しており、知識・技能不足を原因として災害を惹起したケースも決して少なくないはずである。その場合、知識・技能のどの部分が足りなかったのかが浮き彫りになるような立体的・多角的な科学的調査が求められると思料するが、そのような視点での記述がなされているものは見当たらない。安衛法改正により法第 28 条の 2 が新たに加わり、事業者におけるリスクアセスメントが義務化された背景の一つに、「発生原因の法違反を伴わない労働災害の割合が増加していること」があったことも踏まえ考えると、災害の主因の判断に違反の有無を直結させるのみで、それ以上の深堀をしないという災害調査のあり方は問題である。

そうすると、このような調査結果に基づいたのでは、就業制限業務の資格の法令上のあり方に切り込むような検討はそもそもできないのではないか。

たとえば、「資格は何十年も前に技能講習を修了して取得したが、その後の当該制限業務への従事は散発的で頻度が少なかった。係る状況下で年月の経過により、知識・技能が薄れ、このことを原因としてついに重大な労災事故を発生させた」などという災害が仮に頻発するのであれば、当該資格制度のあり方として、法令上有効期限を設けるべきかどうか、資格取得時に求める知識・能力の底上げをすべきかどうかなどの検討に値しよう。

法第 60 条の 2 による事業者による安全衛生教育の努力義務も定められているが、罰則付きの法 61 条の規制にはより大きな効果が期待できるので、事業者の負担と災害防止効果をどのレベルで調和させていくべきか検

討してはどうかというのが本意見の趣旨である。

## (2)法人重課の導入

安衛法は、昭和 47 年の法施行依頼、労働災害を激減させるなど、その果たしてきた役割は高く評価される。また、今日では新たな課題も発生し、それに応じた法改正も順次行われるなど、安衛法に求められる役割はさらに広がっている。安衛法の履行を確保することは産業界にとって極めて重要な意義をもつと考えられる。そのような中、いまだ法令順守がなされていない一部の事業者においては、法違反が繰り返され、安全な職場環境が構築されていないという現状も見受けられる。

こうした現状を踏まえて一層の法の履行確保を図るためには、種々の方策が考えられるが、立法政策としては、法人重課も考えられるのではないか。先行導入された金融商品取引法や証券取引法のみならず、近年では廃棄物の処理及び清掃に関する法律、著作権法なども導入されている。法人処罰については様々な議論があるのを承知しているが、実務的には運用歴を重ねている。そこで、現状についてであるが、我が国の特別法犯の法人処罰の中でも安衛法の運用実績は高い実態にある。2019 年の検察統計年報においては、特別法犯の法人起訴件数 1,063 件のうち、最も多いのが安衛法違反 203 件、次は廃棄物の処理及び清掃に関する法律違反 184 件、続いて風営法違反 91 件、入管法違反 73 件などとなっており、特別法犯の法人起訴件数の法例別内訳では安衛法の割合が最も多くなっている。

安衛法違反はいわゆる組織犯罪であり、企業のトップのみならず末端の管理職に至るまで、その権限や授権の実態に応じて行為者になり得るのであるから、犯罪抑止の目的達成のためには、法令重課を導入することによる威嚇効果を用いて企業としての活動を規律し、法の一層の履行確保を図ることを検討すべき時期にきていると考える。

## (3)行政制裁制度の導入

前記(2)と同様、行政制裁の制度を導入することにより、企業としての活動を規律し、法の一層の履行確保を図るために行政制裁制度を導入するもの。具体的には、一定の法違反を繰り返し、行政指導によっても是正の認められない事業者を対象とした企業名公表制度を設ける。背景としては、労働基準行政機関における安全衛生関係の業務に割ける行政のリソースが年々低下していることが挙げられる。労働基準行政は、かつては(特に昭和 47 年の安衛法施工後)企業に対する監督指導において、その多くの部分を安全衛生関係に充ててきたが、平成 14 年頃を境に監督指導の重点を「一般労働条件の確保・改善対策の推進」へ向け大きく舵をきった。長時間労働による過労死や賃金不払残業などが社会問題化したことによる対応するものであり、現在もこの流れはおおむね続いていて、このため安全衛生に関わる行政資源を相対的に目減りしている状況が生じている。その一方で、行政執行体制を拡充し組織を肥大化させることには国民の理解は得られそうもない。そこで投入する行政資源に対する費用対効果の非常に大きいと見込まれる前述の制度を法に盛り込み運用することによって、現行の行政執行体制下においても、より高い効果をあげられることができるのではないかとというのが意見の趣旨である。(00268 元監督官)

●(1)ストレスチェックの実施から事後措置までに相当な時間を要する規定となっており、緊急を要する場合の措置の改定が必要。実施後数カ月要する。

ストレスチェックの実施「遅滞なく」：結果出力後速やかに

↓

本人通知「遅滞なく」：概ね 1 カ月以内

↓

本人からの面接指導申出「遅滞なく」：概ね 1 カ月以内

↓

医師による面接指導の実施「遅滞なく」：概ね 1 カ月以内

↓

医師から意見聴取「遅滞なく」

↓

事後措置の実施(00059 技官)

●(1)よく使用する条文と、そうでない条文の二極化している。また、時代に応じて使用しない条文も多くなってきているため、条文によっては、法令から落とすなどの整理もすえきだと思われる。

(2)化学物質等について、規制する法令が煩雑になりすぎていると思われる。そのため、一度違反を指摘した事業者に犯罪である旨説明するも、その重要性に説得力が無く、結果、繰り返し違反となるために、捜査着手する事案もある。

(3)安全衛生に対する責任者について、事業場において氏名された者に実質的な権限が無い場合や実効性が無い場合が多い。その背景には、指名された責任者自身は、本来業務(生産管理等)で手がいっぱい、所定時間内に、その法的責任を行使できるだけの余裕を与えている。(当該責任者が行う安全管理を把握及び評価する)事業場が少ないからであるが、労働安全衛生法において、この点について規制させる仕組みも必要であると思われる。(00040 監督官)

●(1)有機溶剤中毒予防規則と特定化学物質障害予防規則については、規則制定の趣旨が異なることは十分理解するところであるが、同じ化学物質の規制とするものであり、大きく見直す必要があるものと考えられる。

(00184 技官)

●(1)罰則が諸外国と比べて全般的に軽いため、より重い罰則内容とすべきである。

(2)健康診断の実施義務は、事業者ではなく、社会保険など他の健康診断と統合して、労働者本人の受診義務に変えて、その健診結果を事業者に提出するようにすべきと思料される。

(3)昭和47年施行から現代の流れが変わり、機械設備が進化しているので、現代の機械を当時規則に当てはめて適用になるかを検討しているので、機械装置の実態に適さない規則になっている。古い規則は削除すべきで、一般規則に含めた方がよい。

(4)特別教育などの「教育」については、事業主の実施にせず技能講習に格上げし、義務化すべきである。

(00141 技官)

●(1)安全衛生法の免許の再交付について、労働局労働基準監督署の窓口へ本人確認に行かないとにならないが、ネット申請等で対応可能と思われる。(00025 監督官)

●(1)KYなどの安全活動の実施義務化(00142 技官)

●(1)書類の保存期間の統一

バラバラすぎる。

作業記録や健康診断の結果の保存が、労働者が病気にかかった場合における過去の作業状況や健康状態の把握と健康状態の変化を追跡することを目的とするのであれば、一律最終記入日から30年でもよいのではないだろうか。

また会社に対して、退職労働者への健康診断の結果の写しの交付の義務化、労働者が雇用された場合に雇用者への当該健康診断結果の写しの提出の(努力)義務化も検討してもよいのではないだろうか。(00071 監督官)

●(1)労働基準法では義務の主体である「使用者」を「事業主又は事業の経営担当者その他その事業の労働者に関する事項について、事業主のために行為をするすべての者をいう」と定義しており、世間の常識と一致して



います。一方、労働安全衛生法では、第2条で主要な措置義務の主体である「事業者」は「事業を行う者で、労働者を使用するもの」と、事業主（個人及び法人）自体を義務主体としておきながら、第122条で突然「法人の代表者又は法人若しくは人の代理人、使用人その他の従業者が、その法人又は人の業務に関して、（中略）違反行為をしたときは、行為者を罰するほか、その法人又は人に対しても、各本状の罰金刑を科する。」との両罰規定が定められていて、現実具体的な措置を行うべき者は誰なのか、わかりにくい複雑な規定の仕方をしています。私ども行政に携わってきた者は、違和感を持ちながらもこの考え方に慣れてきましたが、労使が働く現場の当事者に素直に理解・納得できるようにしていただきたいと思ってきました。

(2)労働安全衛生法第91条・第94条により、それぞれ労働基準監督官及び産業安全専門官・労働衛生専門官には事業場への立ち入り等の権限が与えられていますが、労働基準監督署の規模により産業安全専門家も労働衛生専門家も配置されていない監督署が少なからずあり、それらの監督署でも安全衛生業務を担当する厚生労働技官は当然事業場に立ち入る等の行為を行わなければその職掌を全うすることができないにもかかわらず、その権限に法的根拠がないという状態が継続しております。(00088 元監督官)

●(1)罰則が諸外国と比べて全般的に軽いため、より重い罰則内容とすべきである。(00141 監督官1)

●(1)法令に規定した内容は、事業者、労働者ほか関係者が遵守することを求めているのに、法令の条文に他の条文の参照が多く、理解するのに手間がかかる構成となっている。各条文を見ればその内容が分かるようにすべきと思料します。

(00180 監督官)

●(1)「常時」について、頻度や使用量を定義し明確化すること。有機溶剤中毒防止規則等有害物に係る規制で規定されることの多い「常時」について、定義が明確でないことから、現場により解釈が異なり、全国斉一的な法令の適用を困難にしていると思料するため。

(2)特定化学物質障害防止規則、有機溶剤中毒予防規則、粉じん障害防止規則等の現在単独で規定される各有害物質に関する省令を一本化すること。特定化学物質障害防止規則に規定される特別有機溶剤については、特定化学物質障害防止規則の適用のみならず、準用規定により有機溶剤中毒予防規則による適用も受ける。また、令和3年4月からは、アーク溶接等作業については、従来の粉じん障害防止規則の適用のみならず、特定化学物質障害防止規則の適用も受けることとなる。有害物質に関する知見が深まるにつれて、複数の省令が適用される事案が増えているが、これにより法令の適用関係が複雑化している。法令の適用関係が複雑になると事業場による法令遵守を困難にするため、法令の適用関係の単純化を図る必要があると思料する。

(3)罰則適用の法令として文言の明確化を図ること。安全衛生関係法令は、労働安全衛生法違反被疑事件として立件（司法処分）するにあっては、その条文の文言があいまいであったり（前述の「常時」などの表現）、外形的要因が規定されていなかったり（安衛則第151条の3等多数の条文で規定される「作業計画の策定」については書面での策定を規定しないため外形的要因がない）、あいまいな通用除外が設定されていたり（有機溶剤業務について設置が義務付けられている局所排気装置には「臨時」や「短時間」など定義があいまいな適用除外条件が複数存在する。）することで、捜査を困難にし、立件できない場合もあるため、規定を明確化すべきと思料する。(00181 監督官)

●(1)労働安全衛生法そのもの抜本的な改正（統廃合を含めた大胆な整理）が必要と思われます。長年に亘る改正によりとにかく判りにくい、読みにくい。行政の人間がそうであるから、一般の事業場の人には難解であると思われる。

(2)就業制限業務（特に技能講習）の統廃合。建設機械や荷役機械などで、操作系が同じようなものについては整理が望まれる。また、クレーンや移動式クレーンでは、能力より搭操作系（乗型かそれ以外）で資格を分け

ないと危険であると思われる。

(3)有害物に係る省令（有機溶剤、特定化学物質、鉛、四鉛など）の統廃合

現行は規則が多い割にその対応は似たようなもの（密閉、局排、全換、保護具など）となっている。内容を見直し、化学物質等障害防止規則などに一本化すればよいと思う。（00189 技官）

●(1)第三次産業等に対する法的規制を強化する必要があるものと思料します。

具体的には、業種により法的に義務がない安全管理者（安全衛生推進者）の選任や安全委員会の開催について、業種に限らず一定規模の全ての事業場で選任、開催するよう法制化を検討する必要があるものと思料します。

（安衛法第 11 条、12 条の 2、17 条）

現行、安全推進者の配置をガイドラインで示していますが、労働災害は減少せずに増加しています。

(2)各種報告書の廃止について

ボイラー則及びクレーン則で定められている各種報告書(3 トン未満のクレーン等、1 トン未満のエレベーター、小型ボイラー)について、各製造業者の機械性能の向上及び当該機械に係る事故の減少等により、監督署への設置報告は不要であるものと思料します。（安衛法第 100 条）（00205 技官）

●(1)陸運事業において増加傾向にある荷役作業中の労働災害防止のため、荷主等庭先（荷主等事業場内）で陸運事業者の労働者（ドライバー等）が行う荷役作業に関する安衛法上の荷主等責任が規定すべき。現在は、30 条の 2 の元方事業者としての作業間の連絡調整のみ義務付け。

(2)荷役中の災害として増加傾向にある、テールゲートリフター及び RBP（ロールボックスパレパレット：かご車）を使用する業務を、第 59 条第 3 項（安衛則第 36 条）の特別教育を必要とする業務に追加(000217 元監督官)

●別紙の「労働安全衛生法の問題（メモ）.docx」（別途資料内）に記載いたしました。（番号なし 監督官）

●(1)有機則第 2 条の適用除外基準に関し、第 1～3 種という大きくくりな規制ではなく、取り扱い化学物質の有害性（たとえば発がん性の有無）に応じた基準を設定し、物質によっては規制緩和とすること。

(2)安衛令第 1 条第 9 号の簡易リフトの定義について、現行は「労働基準法（昭和 22 年法律第 49 号）別表第 1 第 1 号から第 5 号までに掲げる事業の事業場に設置されるものに限る」に限定しているが、商業等他業種においても簡易リフトが広く利用され、実際に死亡災害が発生しているところから、適用範囲を全業種に拡大すること。

(3) 安衛令第 6 条第 12 号における「はい」の定義について、現行は「倉庫、上屋又は土場に積み重ねられた荷」と限定列挙となっているが、これに「船倉」を追加すること。港湾荷役業における労働災害は、沿岸だけでなく船内荷役においても発生しており、中には死亡等重篤な災害が発生しているため、船内におけるはい作業の規制を設ける必要があると思料する。（000157 監督官または元監督官）

●(1)ボイラー則

23 条「就業制限」の令第 20 の 3(・・・取り扱いの業務)、に対して 23 条「作業

主任者の選任」の令 6 の 4(・・・作業)について、運転資格のそのものの要件と、ボイラーの種類・規模による主任者の免許ランクによる選任要件が、絡み合っていることから、錯誤が生じ時に混乱を起し間違った理解がされる結果となる。

## (2)事務所衛生基準規則

環境測定では、デジタル化などで、簡便に正確に測定することが可能であることから、機器の選定(8条)や測定者の要件(資格)を含めて見直しが必要。また、休養室(21条)では、部屋の大きさ・空調など一定の基準や、救急用具・設備(23条)では、自然災害への救急対応を視野に入れた内容の検討が指摘されます。

(3) 構造規格に関しては、墜落制止用器具(フルハーネス安全帯)の2条(使用制限)は、主として事業者(ユーザー)に対する規制であり、構造規格としてのおさまりが良くない。(00283 元監督官)

●(1)労働災害における労働安全衛生法違反の捜査に際しては、措置義務があることの認識、その認識を持った時期や理由、措置義務を実行しなかったことの原因など、いわゆる故意が必要であり、業務上過失致死偽罪のように、過失犯を処罰する規定になっていない。そこで、労働災害を防止する措置のように、状態が危険な方に悪化するのを防止する措置においては、必要性、緊急性が高く、故意とかとは関係なく、過失犯も処罰できるようにすることこそが、「労働者の生命・身体を損ね、健康を害する労働災害を予防する」という立法趣旨にかなうと考える。(00097 監督官)

●(1)「常時」という文言の明確な定義及び判断基準が定められていないことから、特殊健康診断の実施等の要否について、各人ごとに判断が異なってしまうこと。

(2) 条文の読み替えに関する規定が多数存在し、法令の解釈に不慣れな者が当該条文の内容を理解するうえでの大きな障壁となっているものと考えられる。したがって、条文中の文言及び定義の整理や複数の条文間における規定内容の調整等が必要ではないか。

(3) 同一の機械設備を同様の条件で使用していたとしても、使用する目的の違いによって、法令の規制の対象外になると解されるものが一部存在すること(例：乾燥設備について、物の加熱乾燥を行うものは対象となるが、同一の使用条件で乾燥を伴わない焼結や熱硬化反応等のみを行う場合には対象とならないと解される)。(000155 不明)

●(1)複雑になりすぎて、条文の理解が困難となっている。特別有機溶剤等などの規制の単純化。(00027 監督官)

●(1)一般の人が調べてわかりやすい法にするため、法の再構築が必要。(00174 監督官)

●(1)労働安全衛生法の目的を達成し、事業者がその責務を果たすためには、外部専門家(専門的機能を持つ機関も含む。)を活用するための新たな資格制度を導入(創設)することを検討すべき。例えば、法第28条の2のリスクアセスメントを事業者が適切に行うためには、外部専門家の活用を図れるようにすべき。現在、労働安全衛生の専門家として労働安全衛生コンサルタントが規定されているが、現行の規定では、このような専門家が積極的に安全衛生法の執行に関わるものとはなっていない。労働基準行政で、地方での技官の採用を止めている状況を踏まえると、行政としても外部専門家の積極的な活用を図る必要がある。

(2)労働安全衛生法では、法の目的を達成するため、検査・検定、試験、教育等の業務を外部の機関に委ねる仕組みとしている。これらの機関については、法令で一定の要件を定めているが、国際的にみると、その要件は緩く、見直しが必要と思われる。我が国は、TBT協定を批准しており国際的なルールと遜色ない制度とする必要があるが、現行の要件をみると、品質マネジメントシステム(ISO9001)、試験所・校正機関の認定(ISO/IEC17025)、製品認証機関の認定(ISO/IEC17065)等を意識したものとなっていない。グローバル化が進む中で、我が国の制度がガラパゴス化しないためにも、労働安全衛生法の下で、重要な役割を担うこのような機関のあり方(期待される役割の十分な発揮)について規定を見直す必要がある。



(3)特定機械等(法第 37 条)への規制は充実しているが、それ以外の危険な機械・器具への規制については一度規制の範囲、その内容を検討してみる必要があると思われる。私の勤務先では、防爆電気機器、呼吸用保護具等の検定を行っているが、防爆電気機器に関して言えば、国際的な試験・認証の仕組みである IECEx からは遅れたものとなっており、試験・認証の基準である防爆機器の構造規格及び安全衛生規格の規定も国際的に通用する IEC 規格の思想から遅れたものとなっている。また、呼吸用保護具関係で言えば、検定対象は、防じんマスク、防毒マスク、電動ファン付呼吸用保護具に限られており、行政が通達で注意喚起しているホースマスクについては、検定どころか、性能要件さえ示されていない。(00228 元技官)

- (1)通達や指針による解釈しか示されていないものが多く、分かり難い。明文化等の整備が必要。
- (2)努力義務以外の法でも罰則規程が付されていないものがある。
- (3)法の厳罰化。(00055 監督官)

- (1)違法性の有無の判断をするために告示や通達まで見なければ判断できず、わかりづらい。せめて政省令まで見れば違法かどうか判断できるよう明快なものにすべき。
- (2)可罰性が高い条文については、刑罰法規として適用しやすいよう構成要件を明確な表現にしてほしい。(00121 監督官)

- (1)安衛法が担っている分野が非常に広範囲。また、ボイラー、圧力容器、化学物質、放射線、心身にわたる健康管理などの対策について、他法と重複するものもあり、すみ分け、統合、別だてにするなどの整理をした方が良い。(00185 技官)

- (1)一般定期健康診断の診断項目の改正。
- (2)労働安全衛生規則第三編第一章の二廃棄物の焼却施設に係る作業。(00076 監督官)

- (1)労働安全衛生規則 518 条第 2 項の「防網を張り、労働者に安全帯を使用させる等」の規定においては「防網」・「安全帯」・「等」の 3 つの措置の中の一つの措置のみでよいか又は二つ以上の措置を要するか。
- (2)労働安全衛生規則第 519 条第 1 項の「作業床」は何か。
- (3)労働安全衛生法令における「墜落」と「転落」の差異は何か。(00082 監督官)

- (1)免許申請について、労働安全衛生規則別表第四の「ガスの溶接作業主任免許」の項の第一号には、「次のいずれかに掲げる者であつて、ガス溶接作業主任者免許試験に合格したもの」、その「二」に「職業能力開発促進法第二十八条第一項の職業訓練指導員免許のうち職業能力開発促進法施工規則別表第十一免許職種の欄に掲げる塑性加工料、構造物鉄工科又は排管料の職種に係る食上訓練指導員免許を受けたもの」とされている。他方でガス溶接作業主任者免許規定第二条「労働安全精鋭規則別表第四ガス溶接作業主任者免許の項第三号の労働大臣が定める者」として、第八号に「職業能力開発促進法第二十八条第一項に規定する職業能力開発促進施工規則別第十一の免許職種の欄に掲げる塑性加工料は溶接科の職種に係る職業訓練指導員免許を受けた者」とある。本省見解は、「免許試験合格と無試験との両方に書いてあるので、免許申請者に不利益にならない取扱いをする結果、無試験で免許を交付する扱いとなる」とのこと。つまり、条文上の齟齬があると思われるので、改正が必要と思料されます。また、試験免除となる職業能力開発促進法に基づく訓練の終了証に記載されている根拠条例も必ずしも労働安全衛生規則別表第四やガス溶接作業主任者免許規定の表現と一致しておらず判断に迷う原んとなっているので、別表・免許規定（又は終了証の根拠条項記載の仕方についても見直しをはかるべきと思料します。(00166 監督官)

●(1)労働安全衛生法第27条第1項により、第20条から第25条まで及び第25条の2第1項の規定により、事業者が講ずべき措置及び前条の規定により労働者が守らなければならない事項は、厚生労働省で定めると規定されており、省令に講ずべき措置等が委任されているが、法の定めが抽象的で省令に根拠条文を引用していないため、根拠条文が曖昧になるため、省令に根拠条文を引用する等により根拠条文を明確化する必要がある。(000186 監督官)

●(1)リモートワークと現行労働安全衛生法及び関係省令との整合性。(00206 監督官)

## ■設問他

私は労働基準監督署の安全衛生部署に勤務する厚生労働技官です。

1年目の研究成果を拝見させていただきました。労働安全衛生法に携わる者として、改めて法の目的、社会的背景、法制定の経過、そして何より労働者を守るため多くの人が携わり今もなお成長し続ける同法について再確認する機会となり身が引き締まる思いです。

さて、貴プロジェクトとは直接関係ない話かもしれませんが、現在我が国の安全衛生行政の状況について参考までに述べさせていただきます。現在国家公務員は政府の「定員合理化計画」により、行政機能の低下を無視した人員削減が強行されています。その中で、主に安全衛生業務に携わる「厚生労働技官」の採用が10年以上にわたり凍結されており、労働災害や職業疾病の防止のために必要な知識や経験を持った担当官は大幅に減少し、安全衛生業務に携わる厚生労働技官が0人という局も存在します。知識や経験の継承ができずそのレベルは絶望的に低下しており、我々は厚生労働省に対し厚生労働技官の採用再開を訴えていますが（政府の指示なのか）全く採用を再開する気はありません。厚生労働省は理系の監督官に安全衛生業務を行わせると言っていますが安全衛生業務を行うためには長期の教育が必要です。十分な教育を行う期間がなければ安全衛生担当者としても中途半端になりますし、本来の監督官業務の専門性も低下してしまいます。

また、現在政府は行政の現場に実績主義を導入し、労働者のためではなく件数をこなすための職場と成り果てています。安全衛生業務は、法改正をはじめ日々変化する社会情勢、業界の状態、新しい機械や工法の導入など、新たな知識を得るために勉強しなければなりません。昔、先輩からは勉強も仕事だといわれ、業界誌などに目を通し、時には事業所の管理者や労働者と話を生息の情報を仕入れ業務の参考としてきました。しかし、今は件数をこなすことに忙殺され、勉強をする時間がありません。法改正についても十分に理解する時間がないほどです。このような状況で国民のための行政ができるでしょうか。

1年目の研究成果からわかるとおり、安全衛生業務は範囲が膨大で、様々なことを勘案し効果的な指導を行うためには経験が必要です。常日頃から私は言っていますが、安全衛生業務は事業者に法律を守らせるのではなく労働者を守るための指導をしているということです。そのためには労働者を守るという信念と災害の原因の根本を見極める能力が欠かせません。法条文の指摘だけでは労働者を守れないのです。

貴プロジェクトの目的が、単に法体系の整理にとどまらず、真に労働者を労働災害や職業性疾病から守るための効果的な施策を提言するためのものであるならば、現場の第一線に必要な能力を持った安全衛生担当者を配置し、十全にその能力を発揮できる体制の確保を提言していただきたいと考えます。さて、ここからが貴プロジェクトに関しての意見なのですが、貴プロジェクトの基礎知識がないので的外れなことを書いていたらすみません。

まず目的についてです。

「①技術系の色彩の強かった労働安全衛生法を事務系にも理解してもらえるようにする」ですが、労働安全衛生法はその性質上、技術系に特化した部分があるのはやむを得ず、力学や鋼材の性質、風量計算、さらには医学的な知識などを事務系の方に理解してもらうのは現実的ではないと思われます。広く一般に労働安全衛生法を理解してもらいたいという趣旨は理解できますが、むしろ技術系と事務系を明確に分け、技術的な専門性を



監督署がしっかりと指導できるようにし、事務的な法条文等を広く一般に周知する方策を検討すべきではないでしょうか。

結果的に労働安全衛生法を骨抜きにし憲法にも定められた労働者の権利を後退させる恐れがあるため現場の職員としては反対です。（そもそもそういう趣旨でなかったら申し訳ございません）

次に「②同法に詳しい学者や専門家を増やす」ですが、我が国の安全衛生水準を向上させるためには当たり前のことなので増やすこと自体に異論はないのですが、この目的が「同法に詳しい学者や専門家を増やし、国が行う安全衛生にかかる業務を外部委託する」であれば論外です。労働安全衛生業務は国が責任をもって、対応を行い、生産性効率性を優先し労働者の安全衛生対策を疎かにする者も出てくるでしょう。また指導が必要な事業場に対しての権限など様々な問題が生じると思います。

また、せっかく専門家を増やしてもそれを活かすシステムがなければ有効に機能せず、肩書を持った人が増えるだけ、という事態になりかねません。

事業場が安全衛生管理のため外部資源である専門家を活用しやすくする環境を整備することは非常に重要なことですが、それは安全衛生管理に前向きな事業場が活用するわけで、広く一般の事業場の労働安全衛生水準を向上させるためには、公的機関である労働基準監督署がしっかりと指導できる体制と能力の向上が最も重要と考えます。

「3.現在の労働安全衛生法について、専門家が本格的に検討すべきと思われる課題を、次のうちから3つ選んでください」について、いくつか現場担当官の立場から意見を書かせていただきたいと思います。

「①条文に出てくる「危険を及ぼすおそれ」とは何か、どのように判断すべきか」について、基本的に条文では「〇〇により労働者に危険を及ぼすおそれのあるとき」などと書かれており、ある程度特定されたリスクによる大なり小なりの災害のリスクがある場合はその防止対策を講じるように記載されています。「どのように判断すべきか」の趣旨がよくわかりませんが、リスクがあるなら対策を講じなさい、という判断にしかならないと思います。これを定義づけしてしまうと、安全衛生行政は大きく後退してしまいます。例えば事業場（主にゼネコン）からよくある質問で、「高さが2m未満の作業床には手すりは必要ないですよ（安衛則519条参照）」と聞かれます。その際は「おたくは法律を守れば労働者が死んでも構わないという考えなのですね」と言って説教します。確かに労働安全衛生法は事業者を守るべき最低基準を定めたものですが、法条文に基準を明記してしまうとそれにとらわれてより安全な対策を講じなくなるおそれが高い（主にゼネコン）ので、法条文は現状を維持し、リスクについて事業場にしっかりと説明できる担当官の育成が不可欠であると考えます。

「②条文にでてくる「常時」とは何か、どのように判断すべきか」について  
確かに「常時」については定義がなく、我々も事業場への説明に苦慮しているところではあります。有害業務の常時性について質問された際は、「常時についての基準は明確に示されていないが、業務として当該業務を行う場合は当該業務に常時従事しているものとして対策を講じてください」と説明しています。有害業務の中には体内への蓄積により障害が発生するもの（粉じんや特定化学物質等）もあり、作業頻度が少なくても長期間従事することにより疾病を発症するリスクがあります。常時の基準をめいっかうに定めてしまうとその基準以下で長時間有害業務に従事した労働者は、法定の作業管理や健康管理などが行われず、発症のリスクがあるにもかかわらず何ら対策を講じないというケースが発生するおそれが高いです。また、安全衛生管理対策にかかる「常時〇〇名以上を～」という表現も非常にわかりづらいと考えます。いっそ法条文から「常時」という言葉を撤廃するのはいかがでしょうか・・・。

「③「事業者」とは」

安衛法の2条に定義がありますし、貴プロジェクトのメンバーであれば明確に説明できる方がいると思います。「事業者」と「使用者」の違いが分かりづらいという人はいるかもしれません。

#### 「④建築工事での労災を～」について

まず設計者についてですが、どんな図面を引こうと発注者の責任で発注するわけですので、設計者に法的義務を課すのは現実的ではないと考えます。発注者に関しては、建設工事従事者の安全及び健康の確保の推進に関する法律（平成28年法律第111号）が平成28年12月16日に公布され、安全に配慮した発注が義務付けられています。これは国と都道府県の発注に限定されており、これが市町村にも波及することを期待しておりますが、まだまだ予算重視で安全を軽視した発注が多く出されているのが現状です。

一定規模の足場等について監督署に設置届を提出することが義務付けられており、審査の結果法違反の部分については当然是正させますが、中には法違反ではないがより安全な構造にするべき事案もあります。

しかしながら、発注者の中には法的に問題ないなら予算は出さない、やるなら元請の自己負担で改善しろ、という安全意識の欠片もない発注者も存在します。届出の必要のない工事であればなおさら監督署の審査なしで不安全な発注がなされていることは容易に想像がつきます。

このような現状なので、法的義務を課すのは賛成なのですが、そうすると「どこまで」法的義務を課すのか、という非常に難しい問題に直面すると思います。法的義務を課す以前の問題として、「安全に配慮した発注とは何か」を発注者に周知、教育し、まずは発注者としてのモラル向上が必要と考えます。

個人的には発注者に法的義務を課して安全に作業できる発注が定着してくれることを望みます。

#### 「⑦と⑧」経営層の安全衛生意識の向上及び中小企業の安衛管理向上の方策について

正直に言ってそんな方策があれば苦労しないというのが率直な意見です。

昔に比べ労働安全衛生の重要性、必要性は認知されていますがまだまだ十分ではなく、特に労働安全衛生にコストと労力を割く余裕のない事業場はどうしても対策が後手に回ってしまいます。余力があってもしないところはありますが、産業界に蔓延する人不足の現状も安全衛生活動停滞の一因と考えられます。

法律で無理やり守らせるというのも一つの手段かもしれませんが、労働安全衛生法の重要性について周知し、自らが進んで安全衛生対策を講じるような社会の流れを作る必要があると思います。理想論です。

#### 「⑭増加する高齢者～」について

高齢者の労働災害等については、何年前か忘れましたが政府が年金の支給時期について検討しているという報道が出された時、絶対に高齢者の労働災害が増えると全国の担当官が危惧し、実際に想像以上の件数が発生し、重篤度も高い災害や死亡災害が多発している状況です。

労働力不足について安易に高齢者や外国人、非正規雇用を利用する政策に対する怒りや不満はありますが、ここでは控えさせていただきます。

高齢労働者の問題については、事業場において一般の労働者と同じように使用し特段の対策を講じていない現状が圧倒的であり、今後も増加の一途をたどることは確実だと思われます。この現状を改善する方策は残念ながら無い、若しくはあったとしても焼け石に水となることは明確です。

現実的でないことを承知の上で対策を考えれば、65歳以上の労働者を雇用しない、または65歳以上は管理業務や後任の指導・育成を行うなど現業以外の業務をさせる、労働保険料率の高い業種（比較的危険な業種）には就業させない、などの対策が少なからず効果があるかもしれません。労働力が不足しているから高齢労働者は犠牲になっても構わない、という現状は何としても改める必要があると思います。

#### 「⑯地域と職域の健康管理の連携～」について

安衛法に基づく健康診断の受診義務がない労働者については、地域保健での受診率を高める必要があります（00213技官）

### 三. 研究班會議議事錄



# 厚労科研安全衛生法学プロジェクト会議記録（2020年度）

	日時・場所・概要	頁数
第9回	<p>2019年4月17日(金) 13:30~16:00            於) Zoom会議            概要) 研究代表者の三柴座長から、分担報告書および原稿執筆の際の留意点が説明された。森委員から労働安全衛生法における健康診断制度に関する分担研究報告書の内容が報告されたほか、藤森委員から労働安全衛生法制における「危険」の概念に関する報告がなされ、それぞれについて質疑応答があった。</p>	<p>1            (※第9回は前半・後半の区分なし)</p>
第10回	<p>2020年5月22日(金) 13:30~16:30            於) Zoom会議            概要) 研究代表者の三柴座長から、今年度の調査研究方針の説明がなされたのち、石崎委員の報告書に対する唐澤委員のコメントが報告され、次いで吉川委員により「特定の災害からガイドラインが発出されるまでの流れ」、森委員により「労働安全衛生法令に基づく化学物質による健康障害防止対策の現状と課題」についての報告がそれぞれなされ、質疑応答が行われた。また本プロジェクトにおける横断的課題の説明を経て各課題の担当に関する調整が行われた。</p>	<p>前半… 21頁            後半… 39頁</p>
第11回	<p>2020年7月3日(金) 13:30~16:30            於) Zoom会議            概要) 研究代表者の三柴座長から、新規参加者の紹介、今年度の調査研究方針の説明、分担範囲の調整等がなされた後、藤森委員より「産業用ロボットへの接触に関する規制について」の骨子が、原委員により横断的課題と今秋学会報告予定のテーマとをあわせ「ドイツ労働安全衛生法制における「危険可能性 (Gefährdung)」の概念及びわが国の法令・判例の中に見出される共通項」が、佐々木委員より「労働安全衛生法第22条から23条の逐条解説」についての報告がそれぞれなされ、質疑応答が行われた。</p>	<p>前半… 48頁            後半… 71頁</p>
第12回	<p>2020年8月6日(木) 13:30~17:00            於) Zoom会議            概要) 研究代表者の三柴座長から、新規参加者の紹介、逐条解説の分担範囲の再調整、今年度の調査研究方針の再確認がなされた後、高木委員による中小企業の建設安全の研究経過報告、藤森委員による横断的検討課題（産業ロボットへの接触に関する規制）の研究経過報告、角田委員による現場的視点から見た安全・衛生コンサルタント制度、企業の労働安全衛生の実際に関する報告がそれぞれなされ、各報告に関する参加者からの質疑応答が行われた。また、主に法学系の分担執筆者数名から各分担範囲の進捗状況について簡潔に報告がなされた。</p>	<p>前半… 77頁            後半… 111頁</p>
第13回	<p>2020年9月10日(木) 13:30~17:00            於) Zoom会議            概要) 研究代表者の三柴座長から、横断的検討課題の担当者の再調整、今年</p>	<p>前半… 133頁            後半… 151頁</p>

	<p>度の調査研究方針の再確認および分担報告書の執筆要領の説明がなされた後、畠中委員による講話（現行安衛法が労災防止効果を持った要因、直面する課題と考えられる有効な対策）、森委員による横断的検討課題（労働安全衛生法令に基づく化学物質による健康障害防止対策の現状と課題）の研究経過報告、浅田委員による横断的検討課題（安全関係の特別規則の趣旨と概要、統合の可能性）の研究経過報告、藤森委員による横断的検討課題（衛生関係の特別規則の趣旨と概要、統合の可能性）の研究経過報告、三柴先生による横断的検討課題（性能要件規定の是非と射程）の研究経過報告がそれぞれなされ、各報告に関する参加者からの質疑応答が行われた。</p>	
第14回	<p>2020年11月21日（土）13:30～17:00 於）Zoom会議</p> <p>概要）研究代表者の三柴座長から、現在進めている調査研究に関する説明がなされた後、唐沢委員による講話（海外の安全衛生法制度から日本が学ぶべきこと）、浅田委員による報告（安全関係特別規則の趣旨・概要の解説）および藤森委員による報告（衛生関係特別規則の趣旨・概要の解説）がそれぞれなされ、次いで分担報告書の概要報告として北岡委員（罪刑法定主義と安衛法）、大藪委員（安全衛生に関する免許制度等）、平岡委員（建設安全の規制科学）から報告がなされ、各報告に対し質疑応答が行われた。</p>	<p>前半… 165頁 後半… 181頁</p>
第15回	<p>2020年12月24日（木）13:30～16:30 於）Zoom会議</p> <p>概要）篠原委員による「安全衛生法と現場、安全衛生教育の効果」の報告および質疑応答が行われた後、三柴座長より行政官向けに実施された社会調査アンケートの結果報告、石崎委員および長谷川委員による経過報告と質疑応答、愛知産業保健総合支援センターの大久保副所長により化学物質管理に関する監督指導現場の実態に関する報告を経て、原委員および淀川委員による経過報告と質疑応答が行われた。</p>	<p>前半… 199頁 後半… 213頁</p>
第16回	<p>2021年1月23日（土）13:30～16:30 於）Zoom会議</p> <p>概要）三柴座長によるイギリスの社会調査結果およびわが国の行政官向けの調査結果に関する報告ののち、森山監督官による安全衛生に関する監督指導の実態と法改正の提案に関する報告および質疑応答が行われた。次いで、三柴座長、佐々木委員、山本委員、阿部委員より各研究経過報告がなされ、それぞれに対する質疑応答が行われた。</p>	<p>前半… 226頁 後半… 241頁</p>
第17回	<p>2021年2月27日（土曜）13:30～17:00 於）Zoom会議</p> <p>概要）三柴座長より報告書執筆上の際の留意点が述べられた後、玉泉委員から「現場でのリスクの見極め方」、藤森委員から「労働衛生関係の特別規則の趣旨と概要、統合の可能性」に関する報告とそれぞれに対する質疑応答がなされ、次いで石崎委員、阿部委員による各研究経過報告がなされ、それぞれに対する質疑応答が行われた。</p>	<p>前半… 257頁 後半… 270頁</p>



三柴 本日はご参集いただきましてありがとうございます。よろしくお願いいたします。まずは、新任の委員の方から自己紹介をいただきたいと思います。山本先生からお願いいたします。

山本 法政大学で非常勤講師をしております山本圭子と申します。今回から参加させていただきます。よろしくお願いいたします。

内藤 独立行政法人労働政策研究・研修機構（JILPT）副主任研究員の内藤忍（ないとうしの）と申します。特に職場のハラスメントを研究しています。よろしくお願いいたします。

阿部（未央） 山形大学で労働法を教えております阿部未央と申します。よろしくお願いいたします。

三柴 では、他の皆さんは時間の関係上、ひと言ずつでけっこうですので、ご挨拶いただければと思います。

（各出席者より、氏名・所属等自己紹介がなされる）

三柴 ありがとうございます。では、早速議事に入りますが、まず開催要項をご覧ください。昨年度（今年3月末まで）に執筆していただいた分担研究報告書について、現在概ね要約を作り終えています。そこで気付いた今後の執筆に際して、ご留意いただく点についてお伝えしたいと思います。この点は重要で強調したいことなので、新たにご参加いただいた先生方も含めご銘記していただくようお願いいたします。

とにかくこのプロジェクトでは、安衛法に親しみのない方にどれだけ安衛法をリアルに伝えるかが重要な課題です。安衛法は現場の学問であり現場の法律学なので、現場をリアルにイメージできるような体系書を作るということを目的としています。しかし、提出していただいた報告書のなかには、まだ文字情報ばかりというものが多く、厳しい言い方で申し訳ありませんが、今まで公刊されたものとさして変わらないものが散見されます。この点は今後留意して改めていただきたいと思います。とにかく分かっていない方に分かっていただく必要があるので、安全衛生に関する専門的・技術的用語についての適切な解説をお願いします。たとえば、いきなり“局所排気装置”とかいっても、親しみのない人にはまったく分かりませんし、また建設安全関係でも専門用語が多数使われていて、たとえば“土止め支保工”といわれても読んでいる人は首をかしげるわけです。要するに専門外の人にとって当たり前でない用語が多数出てきます。特に、安衛法はあらゆる産業分野に介入して労災を防ごうというのが基本ですから、学際的な内容になり、少しでも分野が異なると分からなくなります。特にボイラーのような専門的な技術になると、専門用語が数多く登場するので、用語解説が不可欠です。それも、自分の頭で考えるのではなく、分野違いの人から見たらどうかということイメージしながら書かなければなりません。以上のとおり、用語解説を充実させていただきたいのと、併せて図で示すということを徹底してください。

もう一点強調したいのですが、せっかくプロジェクトチームの中に別な分野の方がいらっしゃるのに、まったく質問をしていないということです。このため、分担研究報告書では既存の法律条文の解説に偏っていて、その条文がどう使われているかという適用の実際が見えてこないわけです。せっかく監督官

経験者の方もいるわけですから、当該条文を活きた法としてどのように使ってきたかという現場経験を確認しないとつたないですし、狙い通りの本もできません。肝心なのは、各条文の解説から現場のリアルが伝わってきて、その条文の意味が鮮明になるような書き方です。

また、判例の情報がまだ不足しています。安衛法は法律家にとっては未だにマイナーな法律で、人によっては“こんなのは法律じゃない”という人もいるほどで、法律家には親しみのない法です。なので、法令関係の業者が判例の整理をする際にも、あまり調べていないのではないかという感じがします。しかし、安衛法の重要さを理解している人は、自分が書く解説書や研究書においては適切な判例を調べて掲載するわけです。そういう判例をピックアップしないで業者がデータベース化したものだけを当たっていると、適切な判例にたどり着けません。その点はきちんと文献レビューを行って、安衛法にこだわってきた人が書いてきた本に掲載されている判例情報を洗い出してください。それと、単に判例を挙げただけではだめで、その判例から何を学べるかという示唆の汲みとりがなされていない書き方が多かったです。“こういう判例があります。以上。”というように、普通の法律学の教科書に載っているような書き方で終わっているものが多く、それでは現場のリアルがまったく見えてきません。何度も指摘しているように、安衛法は現場の労災を減らすためにある法ですから、そのために現場で使われる機械の安全化を図るとか、化学物質を安全にするとか、あるいは人の行動を制御するといったように、安全行動を誘うために存在する法なわけです。そういう意味で判例から何を学べるのか、その判例を災害予防に活かすにはどういう風に扱うべきなのかを書かなければなりません。そういった視点がほとんど書かれていなかったのが少々残念でした。

さらに、制度の趣旨を書くようお願いしましたが、これについても有名な体系書や解説書に書いてあることをそのまま拾い上げてくるのではなく、自分で国会の議事録や法令改正の際の審議会議事録などを調べれば、どういう意味で作られた条文なのかがわかるはずですよ。その辺の調査が決定的に不足しているように感じました。あるいは、公式の文書には掲載されていないものの、本プロジェクトに参加されている先生方が知っていることも多いです。唐沢先生にせよ、畠中先生にせよ、生き字引のような先生方がおられるわけです。畠中先生はご高齢のため、今後はインタビューはお受けして下さるということになりましたが、質問内容を要領よくまとめて電話などで対応して下さるということなので、研究チームの先生方をいい意味で活用してください。そうしないと法令の意味が理解できません。単に、書いてある条文の内容や趣旨や関連判決だけを書いただけの本を作りたいのではなく、生きた体系書を作りたいわけです。安衛法を知らない人が読めば、現場のドラマが鮮やかに浮かび上がってくるような本を作りたいと思っています。そこにこのプロジェクトの意味があるわけですが、その辺りがまったく伝わっていない気がします。

それから、今のお話しの延長になりますが、説明が抽象的でわかりにくい部分が多いです。この点、私が書いているものそうなんですけど、要するに学問的に書きたいために、あるいは正確さを重視するために抽象的な書き方をしてしまいがちです。しかし、そのために内容が上手く伝わらなくなってしまう。誰が読んでもわかるように噛み砕いて明確な説明をする必要があるのですが、それが出来ていません。すべてではありませんが、そういう印象を受けました。

法律条文が現場でどう使われているかについては、藤森先生が作成され、玉泉先生も整理して下さったエクセルシートで、重要な条文を色つきで表示していただいています。それを踏まえて、現場で重要な意義を有する条文を銘記してください。藤森先生がこのシートで重要な条文を評価付けしてくださって

いるので、それを受け止めて解説をしてください。

たびたびお伝えしてきたように、私の報告書の作り方が基準になりますが、折々に準拠して書いていただきたい項目立てを示しています。この点、どうしてもバージョンアップをしてゆくことになりませんが、いずれにせよ私の報告書に準拠してください。項目立てについては、必ず私の報告書をご参照ください。たとえば条文の私法上の効果、民事裁判においてどう使われるのかについても、法学系の先生は必ず執筆していただきたいのですが、ほとんどの人は書いていません。私法上の効果については、後ほど法学系の人だけでどういう風に考えるか整理しないといけないと思っていますが、とりあえず自分の担当条文については、文献レビューをしたうえで書いてほしいと思います。それをすり合わせて研究班としての統一見解を出すという形にしたいので、まずは各分担箇所について担当した条文が民事裁判でどう使われるかという点についてよく調べて書いてください。

以上になりますが、ここまでの点について何かご質問ありますでしょうか。

石崎 ナンバリングと構成の点についてですが、昨年来分担報告書を執筆するに当たって示していただいたナンバリングのつけ方、それと最終的に出版に向けて本を作っていくときの原稿のナンバリングのつけ方ですが、両者は同じということでしょうか。あるいは、分担報告書のナンバリングとは別に出版の際の原稿のナンバリングは別であると理解すべきでしょうか。

三柴 私としては、なるべく一致させたいと思っていますが、先ほども申し上げたとおりナンバリング自体どうしてもある程度は試行錯誤になります。とりあえず、以前に統一方針として示していますが、私の分担報告書に準拠してください。これが、いわば試行錯誤の最前線を行くことになります。私の報告書を参考にしながら、どういう項目立てで書けばいいのかをご理解いただき、それを最終的に本にまとめるときのナンバリングと一致するよう、私なりに努力しております。しかしどうしても、試行錯誤はせざるを得ないので、その点は予めご了解お願いいたします。

石崎 わかりました。ありがとうございます。

三柴 今回の会議に当たって私の分担報告書を今一度添付送信させていただいたところです。他にはよろしいでしょうか。

(途中参加した井村委員による自己紹介)

三柴 では続いて、森先生から分担報告書について要点の解説をいただきたいと思います。

森 PDFの資料をメールで配布しましたが(※「健康診断制度の現状と課題」(38頁))、頁数が記載されていませんので、お手持ちのPDFソフトに表記される頁数をご参照しながらお使いください。基本的に研究要旨をご覧いただくと全体像がわかりますが、条文ごとの検討よりもむしろ健康診断制度全体についてまとめようということです。もともと三柴先生から健康診断や化学物質などの選択肢を提示されましたところ、健康診断が入口として取り組みやすかったということです。「研究要旨」に記載した

とおり、健康診断は一般的に・・・以前畠中先生より正式には“一般健康診断”という概念はないのではないかというお話がありましたが・・・特別な化学物質などに曝露している人のための特殊健診と、それ以外のものを一般健診という大枠でとらえています。法律上はそれ以外の健康診断として臨時健診というものがあり、また単に労働者の健診受診義務を定めているだけではなく、その結果を記録・保管する義務を事業者に課すなどといった情報管理のあり方を定め、また健康診断の結果所見があった場合に、その人たちが健康に働き続けられるよう就業配慮等の事後措置に関する規定もあります。健診の結果を本人に通知するのは義務ですが、これに対し努力義務として保健指導の実施が定められています。また、事業場の規模にもよりますが、健診結果を労働基準監督署に報告しなければならない、その様式も定められています。以上は労働安全衛生法の守備範囲なのですが、派遣労働者に関しては派遣法において安衛法の適用関係の規定がなされているので、それらに基づいて健康診断において派遣労働者をどう扱うのかが決まります。

少し詳細な部分に入っていきますが、たとえば産業医の選任義務があるかないかによって事業場の実態に即した医師の意見が聴取できるか否かに差が出るといったような、他の制度との関連で種々の矛盾が出てくることについても確認しています。また判例の話になりますが、健康診断そのものに関する判例、たとえば健康診断を受けさせてくれないことを問責する判例はほとんど存在しません。むしろ結果的に他の問題が起きたときに、健診の実施義務があるのに実施しなかった、あるいは会社側が再三健診の受診を勧めたのに受診しなかった、などといった事実関係が結論に影響を与えるという形の判例がしばしばです。先ほどの健診結果に基づく就業配慮に関連するものとしては、過労死などの事故が発生したときに係る措置が適切に行われていたのかが争点になった判例が散見されます。

研究要旨の箇所に、「課題としては、以下のような事項が挙げた」という項目を十数点挙げていますが、それぞれの項目を考察するなかで今後健診制度と関連して検討を要するものや、先ほど申しました他の制度との矛盾を生じる問題などが、結果として挙げたというのが全体的な傾向です。報告書の3枚目、「C. 研究結果」以降が報告書の内容になります。そこで、研究要旨で挙げた項目の順にしたがって検討を進めていますが、要点を絞ってお話することにいたします。まず一般健康診断に関して、実施そのものに関する問題があります。安西先生の本だったと思いますが、一般健康管理義務と特別健康管理義務があり、前者は有害要因に基づかない個別の労働者に関わる問題であり、後者は特定の要因に曝露する労働者に関するものです。一般健康診断の目的は、全ての労働者を対象に、健診結果に基づいて医師の意見を聴取したうえで、職務適性に応じて就業上の配慮を行うこととされています。根拠条文は、安衛法第66条に紐付く安衛則第43条（雇入れ時健診）、第44条（定期健診）、第45条（特定業務従事者健診）等が規定されており、その他海外派遣者の健診制度もありますが、基本は同じです。健診そのものの実施については、基本的にはすべての労働者が対象となりますので、どの企業で誰に実施すべきかという問題について疑問が生じる余地はないのですが、その中で特定業務従事者健診の位置付けがあいまいで、その背景を別な研究班で調べたレポートが産業衛生学会誌に掲載されました。資料5頁にあるように、健診項目は一般健診と同じですが、特定業務従事者健診を誰に受けさせるかというリストは、工場法時代である昭和15年に改正された工場危害予防及衛生規則に基づいています。それが労働基準法時代に省令に格上げされ、内容的にはほぼ現在に引き継がれているという歴史的背景があります。当時は特殊健康診断自体が存在しなかったため、特定業務従事者健診が負担の大きい労働者のための健診で、途中から年2回実施するようになり、ある程度“バグ”は想定されていましたが、一方で健診項目そのもの



のは一般健診と同じという、きわめて前近代的な内容になっています。多くの産業医に調査したところ、実際に実施している健診項目は、結果的に深夜業の健診がそのほとんどを占めるというのが実情です。さらに、この問題を複雑化している要因は、エチレンオキシドやホルムアルデヒドといった特定化学物質を対象とする健診が今からおよそ10年ほど前に追加になっていますが、これらの物質は発がん性物質であるところ、どの臓器にどのような癌ができるのか特定するのが困難ゆえこれらの検査項目で特殊健診を実施するのが難しい。一方で特化則に入れた以上は何らかの健診を追加的に実施しなければならないので、ある意味苦し紛れに特定業務従事者健診の対象としたという背景があり、そもそも何を目的としているのか理解が難しいところがあります。さらに、どの程度曝露していれば特殊健診の対象となるかについては、昭和20年代に出来た基準から変わっていません。たとえば鉛などは現在の許容度の10倍ほどに設定されています。騒音などは途中で規制内容が変わったのですが、通常であれば85デシベルが第2管理区分となるところ、90デシベルという微妙な数値に設定されています。現実的にはほとんど深夜業以外にしか行われていません。このように、特定業務従事者健診には難しい問題が残っていて、見直しの必要があるものと考えています。

一方で、資料6頁「2. 一般健康診断の対象者」をごらんください。先ほど一“対象者”といっても全員受診させるので問題ないと言いましたが、一般健診に関して短時間労働者をどこまで対象とするのかという問題があります。これについては通達が出されていて（平成19年10月1日基発第1001016号）、「常時使用する短時間労働者」につきどの範囲まで健診を必要とするのか、6頁右段の枠内に書かれています。基本的に、一般健康診断の目的が長時間労働による過重労働を原因とする脳神経血管疾患のみに対処するためのものであれば、短時間労働者は対象外となるわけですが、実際はそれに限ったことではありません。たとえば、血圧が高いまま高所作業をしても大丈夫なのか、あるいは結核に罹患しているのに介護労働に従事させていいのか、などといったことを考えると、労働時間が短いからといって一般健康診断は必要ないわけではありません。健診結果をもとに事後措置を講じる必要があることを考えれば、労働時間の長短によって健診実施の必要性の有無を判断するべきではないわけです。他の健診項目もそうですが、要は事業者自身が各事業場のリスクを理解して、配慮義務を履行するために自主的に実施するのが理想ですが、現実にはそうは言ってられません。そういうことで、一般健診の対象者の確定という点についても課題があるということです。

「3. 一般健康診断の対象業務・要因」（7頁）は、先ほどお話しした特定業務従事者健診と特殊健診との関係について書いたものです。特殊健診の対象となる要因の中で、特殊健診と特定業務従事者健診の双方を実施しなければならないものや、特殊健診のみが必要とされるものなど、様々な組み合わせがあるのですが、それぞれの制度を作った背景や目的がバラバラなので、今現在の在り様に引き継がれています。

「4. 一般健康診断における検査項目」（8頁）は定期的に見なおしがなされています。中でも最近では、平成28年に「労働安全衛生法に基づく定期健康診断等のあり方に関する検討会」が開催され、その結果現行の健診項目になっていますが、健診項目を本来のあり方に持っていくためにはエビデンスだけでは難しく、様々な政治的背景もからんでくるわけです。その中には血液項目の問題も一部あります。また、「既往歴の聴取」という項目が一般健診の中に含まれているのですが、既往歴といった場合に何を既往歴として聴かなければならないかがあまり明確になっていません。あまり突っ込んで聴きすぎるとプライバシーの問題が生じるし、他方でまったく聴かないとなると適正配置に支障が出るという問題が生

じます。そのような課題を指摘しています。

「5. 一般健康診断における健診項目の省略」(9頁)も最近大きな問題が指摘された項目です。規則上、医師が必要でないと認めるときは省略することができるとされ、各項目について「〇歳未満」は省略できるといった要件が定められています。一方、「定期健康診断等における診断項目の取扱い等について」(平成29年8月4日基発0804第4号)では、定期健康診断において医師による省略の判断は、「一律な省略でなく、経時的な変化や自覚症状を勘案するなどにより、個々の労働者ごとに医師が省略が可能であると認める場合においてのみ可能であること」とされています。そうすると、当日の症状如何によって個別に省略の可否を判断することになります。しかし、省略するか否かは健診費用に関わってきます。次の10頁をご参照いただきたいのですが、全衛連(全国労働衛生団体連合)の加盟機関が平成26年度に実施した健診はおよそ3100万件に及び、これは多くの健診が外注によって行われていることを示しています。そうすると、自社で産業医が実施しているケースは非常に少ないものといえます。そう考えると、そもそも外部の健診機関の医師が健診項目の省略を個別に判断するのは現実的には難しいです。結果的に、省略しない健診項目を実施する、つまりは原則全部実施するという形で行われています。平成30年度においては、健診機関は利益が上がって収入が増えたという状況が確認されています。こういう状況の中、本来どういう形で省略すべきかといった議論がまったくなされないまま一律に実施されているのが現状です。

「6. 関連する健康診断」(10頁)ですが、労働者災害補償保険法に二次健康診断等給付という制度があり、一般健康診断で一定の基準を満たした人については、労災保険の適用によって精密検査の受診することができるという制度です。これについてはほとんどデータも議論もないので、制度の紹介にとどめています。

11頁にうつりまして、「II. 特殊健康診断の実施」・「1. 特殊健康診断の実施」についてです。特殊健康診断は労働安全衛生法上、医師によるものと歯科医師によるものがあり、歯科医師による特殊健診は一部の特化則上の物質が対象となります。医師による特殊健診は、安衛法施行令第22条に対象業務を列挙した上で、個々については特別則により各症例でどのような健診が必要なかが規定されています。

「2. 特殊健康診断の対象者」(13頁)にですが、基本的に対象者は「常時性」、すなわち「常時従事する労働者」とされており、「継続して当該業務に従事する労働者」のほか、「一定期間ごとに継続的に行われる業務であってもそれが定期的に反復される場合には該当する」という意味です。たとえば1週間に1回、1時間だけ当該業務に従事する場合であっても対象となります。一方で、慢性的な曝露を原因とする健康障害を前提としたものである場合、作業環境測定の結果が良好であっても特殊健診を実施しなければなりません、その意義はほとんどないと思われます。「常時従事について、科学的知見と照らし合わせた一定のルールが定められるべきと考えられる」ということを議論しています。

「3. 特殊健康診断の対象業務・要因」(14頁)ですが、化学物質以外のものについて法令や規則ではなく、「指導勸奨による特殊健康診断の対象有害要因または作業」として列挙されています。これは基発、つまり通達として出されているのですが、もとになっている法令上の条文が見つかりません。おそらく根拠条文なしに指導という形で出されたのかと思われます。課題の中に書いたのですが、どのような場合に特殊健康診断の対象とするかについて、たとえばトルエンを使ったときにはどんな特殊健診を、あるいはトリクロロエチレンを使用した場合にはこういう健診を、といったように細かく定められてい



ます。しかし産業の現場においては、ほとんどの場合“単剤”ではなく“合剤”つまり混合した物質が使われていますが、こういう場合にその物質が何%以上含まれていれば当該化学物質の特殊健診を実施すべきという定めになっています。その場合、体積ないし重量のパーセントで液体としての割合を計算するため、有機溶剤のように揮発性の高い物質とそうでないものが混じると、労働者は揮発性の高い物質を吸引してしまうという結果が生じてしまいます（たとえばメタノールなど）。そういう特殊性が現在の特殊健診制度の中では考慮されていません。こういう技術的な話をもっと認識する必要があると思うのですが、これを解決するにはどうすればいいか・・・今までの法令が、有害要因に関しては作業列举方式・要因列举方式であって、どういう作業を行ってどういう物質を使っているときには特殊健診や作業環境測定の実施を義務づけられることになっていました。しかし、それでは追いつかなくなったので、リスクアセスメントを実施してリスクが許容できない場合には適切な対応を取るべきという規定が設けられました。そうしてリスクアセスメントを推奨していたわけですが、その後に胆管癌や膀胱がんなど様々な問題が生じてきました。やはり化学物質については未規制物質の問題が極めて大きいので、リスクアセスメントの実施が義務化されました。ということは、一定レベル以上の化学物質を使用している以上、そのリスクを評価しなければなりません。しかし日本においてはリスクアセスメントに関して適切に評価できる人材が育っていないという欠陥があるので、そういう人材を用いる代わりに簡単に評価できるツールを国が提供している。少なくともどの化学物質を使っていれば、あるいはどの程度の濃度を超えていけば特殊健診を実施すべきかという基準は存在するはずなので、そういうリスクアセスメントに基づく対応と、法令上の解釈に基づくものと、2つが現行上存在している状況です。特殊健診については、後者の法令に従って実施しているのが現状なので、その辺りが今後の重要な課題になると思います。

「4. 特殊健康診断の項目」（16頁）については、当然のことながらエビデンスに基づいて見直しが必要となさなければなりません。特殊健康診断は、そのほとんどが労働安全衛生法が制定された昭和47年以降に順次出来ているのですが、当時日本は重化学工業が中心ゆえに相応の高濃度曝露もありました。それがやがて低濃度曝露、慢性曝露となり、発がん性の問題が残っていて、また生殖毒性のような問題が発見されているという状況で、本来それらに合わせて特殊健診項目を変えてゆくべきなのに、なかなかの岩盤で改訂するのにエネルギーが要るのがわが国の法制度の現状です。この辺議論した上で変えてゆく必要があります。最近起きている問題として、厚労省が平成19年度に作業条件の簡易な調査という項目を特殊健康診断の中に入れようとした。なぜかという、作業環境測定をやっている職場はほとんど存在しないので（対象物が限定されるがゆえに）、一人一人の労働者についてどの程度の危険があるのか個人ごとのリスクの評価をしたうえで、特殊健康診断の判定に用いようということを目論んだわけです。そのための委員会を立ち上げてそれなりにいい出来のものだったのですが、諸般の事情によって令和2年までの間棚上げになりました。健診項目を改訂するのはそれくらい難しいということです。作業条件の簡易な調査は、平成20年以降に法令が変わった物質の健診項目には順次入っていましたが、それを入れるだけでも平成19年度に議論を始めてほぼまとまったものが令和2年度になってようやく確定し、今年やっと変わりましたというのが実情です。このように、健診項目ひとつ変えるのもかなりのエネルギーを要するがゆえに、時代に追いついていない状況にあり、さらに未規制物質についてはほとんど何もなされていないという問題があります。

次に「Ⅲ 臨時健康診断」（16頁）です。この制度は規定が設けられているものの、実施されたことはほとんどありません。唯一、東日本大震災に伴う東京電力福島第一原子力発電所の事故に際して、東京電

力等に対して数度の指示が出された事例があります。

ここまでのお話しでわかるとおり、健診制度が裁判沙汰になっているケースはなく、大半が技術的な問題が指摘されている形で議論になっています。

「IV 健康診断の実施に係るその他の論点」(17頁)に移ります。まず「1. 健康診断の実施費用」(17頁)に関わる問題です。基本的には、特殊健康診断も一般健康診断も事業者の義務に基づいて実施されるため、その費用は事業者が負担します。一方で健診を実施する時間については、特殊健診の場合は労働時間とみなされることになっています。一般健診に関しては、解釈例規によれば「一般的な健康の確保をはかることを目的として事業者にその実施義務を課したものであり、業務遂行との関連において行われるものではないので、その実施のために要した時間については、当然には事業者の負担すべきものではない」とされています。しかし最近の動向からすると、過重労働をした人の健康診断に際して、1ヶ月の時間外労働が80時間を超えた人は面接指導の対象となりますが、45時間から80時間までの間は、各人の“一般健診”の結果も勘案しながらリスクの高い場合に面接指導をすべきとされている、つまりそういう形で一般健診が“引用”されているわけです。なので、一般健診が単なる「一般的な健康の確保をはかる」という目的を超えて用いられているわけで、一般健診についても事業者が労働時間内に実施するということがあり得る段階まで来ているのではないかという考察をしています。まあ、さりとてそれが裁判になっているわけではありませんが、現実的には労働時間内に行われている場合が多いようです。

17頁では「2. 健康診断の精度」(17頁)の問題も扱っています。健康診断の精度については、たとえばレントゲンの見落としによって肺がんが手遅れになったとして訴訟になった事案があります。これは少々特殊な例で、健診が企業の診療所の中で行われていたもので、健診を実施した医師とその医師を雇用していた企業が訴えられたケースです。判決は企業の責任を否定しています。すなわち、「信義則上、一般医療水準に照らし相当と認められる程度の健康診断を実施し、あるいはこれを行える医療機関に移植すれば足りる」とのことで、健診の問題は企業が責任を負うまでもないということです。ただ、実際には健康診断は外部機関に委託をするのがほとんどです。その際に、健診機関が提供する項目は比較的標準化されていますが、値段については差が大きく、事後措置が適切に出来るかどうか等精度の高低の問題もあります。そうすると、事業者がどのような健診機関を選択したのかについても責任は問われるべきでしょう。すなわち、本来事業者自身で実施すべき健康診断のクオリティについて、自身が責任を負わなければならないわけですから、外部に委託したとしてもその責任は免れないと思われます。この辺りは未だ議論がなされていません。一方、事業者が外部の健診機関を選ぶためには、各健診機関がどの程度の精度管理を行っているかについての情報開示が必要になります。この点については、全国労働衛生団体連合会や日本人間ドック学会などによる評価・認定は開示されていますので、事業者が相応の努力をすれば適切な健診機関を選択できる状態になっています。、全国労働衛生団体連合会で認証評価を行っている機関が百数十機関あります。しかし、ほとんど認証評価を受けずにまったく競争がないエリアもあり・・・典型例は四国ですが1機関しか評価を受けていません・・・こういう場合には事業者からの質に対するプレッシャーがほとんどないという状態が一部生じています。

「3. 健康診断の実施に係る罰則」(18頁)ですが、健診に関連した罰則規定があります。ただ、罰則があり判例も数件ありますが、健診を実施しなかっただけで安衛法違反で処罰される事案はなく、むしろ結果的に何か事故が起きたときに、判断要素のひとつとして一般健診をやっていたことが問責される事案がほとんどです。資料18頁右段にもあるように、「いずれの事例も他の違反が重なった事

例であり、単独の違反で罰金に科せられる場合はあまりないようである」と記載しておきました。

労働者の側にも特殊・一般双方の健診について受診義務があります（「V 労働者の受診義務等」「1. 労働者の受診義務」18頁以下）。とはいえ、法令上は事業者に課せられる実施義務よりも、労働者の義務を一段下げるとするのが一般的ですから、事業者の義務違反に対しては罰則が適用されますが、労働者の違反にはありません。では、労働者が健診を受けたくないといった場合に、事業者（使用者）がこれに対して懲戒処分をすることが可能かどうかという問題があります。判例としては、公立中学校の教諭が放射線被ばくによる悪影響を理由に、定期健康診断の胸部エックス線検査を受けなかったという場合に、業務命令違反ということで懲戒処分（減給処分）とした事案があります。おそらく教諭という立場を勘案してのことかと思われませんが、判決は減給処分が適切であると判示し、最終的に最高裁で事業者側の勝訴が確定しています。それ以外では、安全配慮義務や健康配慮義務との関係で問題となった事案が散見されます。

「2. 自発的健康診断の結果の提出」（19頁）、これは何かというと、労働時間が長い人で年1、2回の健診以外に自主的にどこかの健診機関で健康診断を受けて、その結果をもとに事業者に配慮を求めた場合に、事業者が所定の措置を講じる義務を課せられています。この条文については、実際はほとんど使われた例がないようなので、ここではこういう規定があるということだけを記載しています。

次に、「VI 健康診断結果の記録と情報管理」「1. 健康診断結果の記録の保存」（20頁）および「2. 健康情報の保護」（20頁）とあります。健康情報の保護については個人情報保護法との関係で、最近かなり具体的に指針が策定され、またその指針の取扱いについて明確化されているという内容を記載しました。主に指針のレベルで触れています。

22頁の「3. 守秘義務」と「4. 罰則」については、概要のみ述べています。

「VII 健康診断結果に基づく就業配慮」（22頁）以降は、判例も相応に見受けられる問題で、健康診断結果に基づく就業措置の話です。まず「1. 健康診断の結果についての医師等からの意見聴取」（22頁）の項に記載したとおり、医師の意見聴取というプロセスを踏まなければなりません。意見聴取の対象は労働者全員ではなく、異常な所見があると診断された労働者とされています。「異常な所見がある労働者」とは、解釈例規によると、「健康診断の結果、その項目に異常の所見があると医師等が診断した者であること」と書かれているにとどまり、その具体的な基準が定められているわけではありません。いずれにせよ、その結果をもとにどのような措置を講ずべきかについては医師から意見を聴取するのですが、医師側が具体的なアドバイスができないと意味のない規定になってしまいます。ここで意見を聴取する医師が誰かということ、基本的には産業医ということになります。では、産業医の選任義務がない事業所ではどうすべきかという話ですが、それを補う形で医師に対して情報提供を行う義務が事業者に課せられています。情報提供を受けた医師が、通常勤務のままでもいいのか、就業制限が必要なのか、それとも休業を要するのかという三分で意見を述べ、事業者はそれに基づいて労働時間の短縮、出張の制限、時間外労働の制限その他を講じなければならないとされています。ただ実際には、一般健康診断の結果だけでは、病状や病名が確定しない場合もあり、その場合には再検査や精密検査を受診してもらわないと結果が確定できないので、そういう受診するよう事業者が働きかけるのが望ましいと規定されています（法令上の義務ではない）。そして、事後措置のうちの精密検査等を受けなかった場合、あるいは受診が望ましい旨を事業者が通知しなかった場合等に関して、いくつかの判例が見受けられます。また技術的な話になりますが、先ほど三分の話が出ましたが、いずれの区分に該当するかの判定基準がありません。現在我々



の研究班で作成したコンセンサス調査というのがあり、当該数値を越えたら直ちに就業制限が必要となるわけではないのですが、“この人については産業医が追加の情報を取得して就業制限をかけるか否か確認する”というコンセンサス基準が最近策定されたところです。さらに、健康診断の実施と確定までの間に時間差があり、その時間差を事業者がどう扱うかという問題があります。つまり、血圧が非常に高めの人が出た場合に、白衣性高血圧かもしれないので、健診実施後1～2週間ほど血圧を測定させその結果をみて治療を受けさせ、血圧が下がった場合には就業制限を不要と判断するに至るまでの手続があります。その間1～2か月の間は原則として一般健診の結果に基づいて、ひとまず就業制限をかけたうえで落ち着いたら元に戻すというプロセスを取る場合と、その間は就業判定を保留にしたうえで最終的に就業制限をかけるかかけないかを判定する手順を取っている場合とに分かれます。たとえばJRなどは前者ですが、多くの会社は後者のようにその期間中判定を保留にしています。このように、一般健診の実施とその結果が確定するまでの時間差をどう扱うかという問題が一部見受けられるという状況があります。

26頁では「2. 健康診断実施後の措置」として事後措置の問題に触れています。健診実施後の事後措置として事業者が講ずべき措置について触れていますが、それが適切でなかった場合に安全・健康配慮義務違反が問われた判例を掲載しました。

28頁では「3. 産業医への情報提供」について述べています。平成30年の労働安全衛生法の改正の際に、産業医への情報提供が事業者には義務づけられ、情報提供の対象項目も明確化されました。

健診についての事業者の義務は別として、最終的には労働者本人がその結果を受けて自分自身の行動を変える必要が出てきます。その点について、「Ⅷ 結果の通知および保健指導」（29頁）という項目で書いています。安衛法上の健康診断は制定当初の昭和47年から実施されていますが、健診結果を一人一人の労働者にフィードバックする義務が定められ、労働者の知る権利を充足する規定になったのは、一般健康診断が平成8年の改正、特殊健康診断が平成17年の改正によってです。そういった規定のもと、健診結果をどのくらいで労働者に返すべきか、などといった問題に触れています。保健指導は努力義務なので、事業者が提供できる範囲内でやればよいということで実施されていますが、最近生じてきた問題としては、高齢者医療確保法に基づいて医療保険者に特定保健指導を実施させる義務が課せられているので、特定保健指導と一般健診に基づく保健指導が重複したり、あるいはその間の情報のやり取りに問題が生じるということが起きています。

31頁の「Ⅸ 健康診断結果報告」では、労働基準監督署への報告義務について触れています。そこでは、「所見のあった者の人数」および「医師の指示人数」という、統計数値になるような項目が含まれていますが、その基準がまったくないので、国が有所見率が上がった下がったと報告してもほとんど意味がありません。せめて何らかの基準なり考え方なりをもう少し明確にした方がいいのではないかということです。

「Ⅹ 派遣労働者に対する適用」（32頁）。派遣労働者に対する労働安全衛生法、特に健康管理に関する規定の適用は、たとえば派遣先企業での有害物質の曝露など結果的に派遣先に問題があるようであれば派遣先に、労働者の一般健康診断のような問題は派遣元にそれぞれ適用されます。派遣先が特殊健診を実施し、派遣元が一般健診を実施するのが基本です。つまり、同一の派遣労働者の健康診断が別々の事業者によって実施されることになるわけです。その際に一般健診を実施した結果、何らかの就業配慮が必要となったときに、直接雇用の労働者であれば健診結果を受け取ったその事業場で就業配慮を受けることができますが、派遣労働者の場合は就業配慮の主体は派遣先ゆえ、派遣先が求めている仕事が出来

なくなる可能性もあり、そうなると派遣労働者は仕事を続けられなくなります。そういう問題点もあるということをご指摘しています。

ということで、健診制度について以上のような感じで検討しています。判例については三柴先生から判例にアクセスするための権限を拝借したりもして調べてみましたが、健康診断については何か事故や災害などが起きたときに問責される事案がほとんどで、それらをもとにまとめてみた次第です。その結果、「D. 考察 および E. 結論」にある内容は、冒頭と同様で、それぞれの項目で今後の検討や議論が必要となる問題を抜き出すと、14項目ほどにまとまりました。

私の報告は以上です。あまり図示がなくて文字ばかりの資料ですが、大丈夫でしょうか。

三柴 ありがとうございます。そうですね、図示を用いるのが適当でない場合に、整理のために表を用いるなどの工夫は必要かもしれませんが、森先生の報告書の内容自体は大変よく整理されていて分かり易い内容となっています。また、報告書の各所で指摘されている諸問題はまさにその通りと思われるものばかりで、非常にありがたいご報告をいただいたと思います。先生方の方からご意見・ご質問はございますか。

石崎 非常に貴重なご報告ありがとうございました。いろいろとお伺いしたいところですが、3点ほど確認させていただければと思います。第一に、一般健康診断の健診項目の省略について、個々の労働者の状況を踏まえてなされるものの、実際には難しいので省略はしないで健診を実施するとのことでした。この点について、森先生としてはどのような形で省略などをするべきとお考えでしょうか。第二に、混合溶剤のお話しの中で、揮発性の高いものとそうでないものが混ざっていた場合に、揮発性の高いものだけを吸うと、両方の物質についてではなく、吸引する可能性の高い揮発性の高いものについてだけ健診を実施すればいいところ、過剰な健診になってしまっているという趣旨のご指摘であると理解してよろしいかどうかということです。またその反対に、本来対象となっていないけれどもRAに沿って健診をやるべきものがあるというように理解しましたが、それでよろしいでしょうか。三点目が、最後の方でお話しされた派遣労働の場合の措置についてですが、就業配慮をした結果派遣切りになりかねないという難しい問題があるところについて、どう対応するのが望ましいのか、その方向性についてお考えがありましたらお聞かせいただければと思います。

森 ありがとうございます。まず最初のご質問についてですが、一定の条件が揃ったときに健診項目を産業医の判断に委ねるという方法しかないと考えています。たとえば貧血検査というものがありますが、有所見は若い女性の頻度が極めて多いのに対し、男性はほとんどありません。そういう設計をそれぞれの職場ごとにある程度柔軟にできるようにするのがいいかと思います。健診項目は個々の労働者ごとではなく一律に決めるわけですが、その一律の内容を事業者が決めるのではなく、産業医が設計する形で省略が可能であれば省略をするという方法がよろしいのではないのでしょうか。

石崎 法令上から健診項目を削るというよりは、産業医の意見を参考に各事業場ごとの裁量に委ねるという手法ですね。

森 そうです。それから、有機溶剤の揮発性の話の中で場合によっては健診が無駄になってしまうのではないかという話でしたが、5%以下の有機溶剤であっても揮発性の高い物質の場合はかなりメジャーな曝露要因となっているのに、それ自体が特殊健診の項目から外れてしまう心配があります。特殊健診は一般健診と違って安全サイドに立って実施した方がいいと思っていますので、むしろそういう心配をしているところです。三点目については、そもそも派遣という制度をやめないかぎり必ず付きまとう問題です。派遣先の目線からすれば、わが社は仕事を頼んだのであって人を頼んだのではないというものですから、その人が頼んだ仕事ができないとなると、“スペックに合わない人”ということになります。一方で雇用契約の相手方は派遣元なので、派遣先に何かしらを義務付けるのは難しいのではないかと思います。私もこの問題は派遣制度そのものの大きな課題だと思っています。

石崎 ありがとうございます。別な問題になりますが、複数就業すなわち副業や兼業の際の労働者の健康確保が現在問題になっていまして、それと似たような部分もあるような気がします。

森 同じ問題ですね。また、短時間雇用の健康診断の問題も現場ではありました。その労働者の主たる就労先が4分の3以上で、残りが4分の1未満であったらどこで健診を受けるかはハッキリしているのですが、全てが4分の3未満であったらもはや自分で受診するしかなくなるわけです。

石崎 もっとも、短時間労働の問題は、おそらく4ぶんの3以上であれば、長時間労働云々というよりは特定の企業におけるメンバーシップ度ないし専属性が高いので、使用者に傷病予防のためのある種サービスを提供させるといった発想に立っているように思われるのですが・・・

森 日本の健康診断制度は、全ての労働者を対象にかなり目の粗いものを実施するのが前提ですが、欧米の健康診断は、特別な職務適性が必要な作業に対してその適性検査をするという発想です。そうになると、短時間の人で一般健診は必要ないとしても、特定の作業に従事するのであれば所定の項目の健診を実施するという発想で追加すれば、おそらくカバーできるのではないかと思います。

石崎 それは現行法のもとでも可能ですね。

森 いえ、現行の法では義務付けられていませんので、要は自主管理のレベルが上がっていかないと難しいところがあります。健診項目や有害物の管理も含め、現行ではあれもこれもとあまりにも細かく法令で規定されているために、これを変更・緩和するのは難しいわけです。なので、プラスアルファとしての自主管理を強制的な管理とあわせて双方実施しなければならないのが現状ゆえに、自主管理はなかなか進みません。

石崎 先日、作業環境測定の関係でインタビュー調査を実施しましたが、そのときにも同様のご意見をうかがったところです。ご回答ありがとうございます。私からの質問は以上です。

三柴 森先生の先輩にあたる方で産業医科大学の学長をなさっていた大久保先生が以前書かれたペーパ



一で非常に適切に整理されていますが、労働環境はその職場全体にわたる問題で、労働者個人は資質や個性がそれぞれ違うわけです。一般健診というのは、労働者それぞれが持っている特質を測定して、一律的な労働環境や作業内容にどう適用させるかという問題ですが、それに対し特殊健診は一律的な労働環境の方をどのように変えていくかという問題です。基本的な整理はそうなのですが、実際は労働環境の方も一律ではなく部署や作業によって違いが出てくるし、個々人の持っている特性も一律にはかれるわけではないし、丁寧にはかろうと思ったら手間のかかる作業です。それゆえ、一般的な専門知識を持ち合わせているだけでなく、当該職場を熟知していて、一般性と個別性の双方に対応できる専門家を養成する必要がある、産業医科大学を設立する意義はそこにあったわけです。90年代に書かれた先述のペーパーにはそういう内容も書かれていまして、今現在も実は状況は変わっていません。なかなか実現の難しい課題というわけです。

森先生は間もなくご退会の時間なので、もうお一方ほどただ今のご報告に対してご質問などございましたらお願いいたします。

鎌田 一点よろしいでしょうか。健康診断の結果を踏まえた就業制限措置についてお伺いしたいのですが、条文上は「必要があると認めるときは」と定められているところ、医師の意見や労働者の意見を聴くといった手続きの面では指針等が定められていると思うのですが、「必要があると認めるとき」か否かの判断は事業者が裁量的に判断をするという意味に思われます。したがって健康診断の結果について医師から何らかの問題が指摘されたとしても、事業者が何も措置を講じないことが現実であり得るということでしょうか。

森 そのようですね。これは事業者責任の最も根幹的な部分なので、それでも事業者がしかるべき措置を講じなかった場合に法令違反と評価すべきかどうかという問題ですね。もしその結果何か起きれば事業者の安全配慮義務違反ということになると思います。

鎌田 そうですね。事故や災害が起きればそうなります。

森 欧米の中で産業医の独立性が担保されている国では、産業医の意見は実質的に命令に近いものと位置付けられている一方で、それに不服がある場合にはより専門性の高い第三者の意見を聴くなどといったプロセスが明確に定められています。そこまで制度設計をしておかないと、産業医が不適切なことを言って事業者が被害を被るといった事態が生じかねません。つまり、そういう制度設計がない限り、産業医の意見について事業者に対する法的強制力を持たせることは難しいかもしれません。

鎌田 森先生が資料の中に引用されている高島屋工作所事件は、労働者側から安全配慮義務の履行請求という形で一定の措置を請求している事件ですが、そういう趣旨でこれを引用されているということですね。

森 そういうこともあり得ると思います。

鎌田 ありがとうございます。

三柴 ありがとうございます。では、森先生のご報告についてはここまでとしまして、次に藤森先生のご報告をお願いいたします。法令上の危険性に関する言及ですが、それぞれどの条文で定められ、どのような趣旨で用いられているのかについて、以前まとめていただいたので、今回新任の委員の方もご参加なので、あらためてご説明いただければと思います。まずは、藤森先生の方から自己紹介をお願いいたします。

藤森 藤森と申します。以前、厚生労働省に勤務しておりまして、現場では監督や労災補償の仕事に携わってきました。また中央労働委員会や内閣法制局、産業医学振興財団での勤務を経て、現在は中災防におります関係で、本プロジェクトに参加させていただきました。よろしくお願いいたします。

三柴 ありがとうございます。では、ご報告をお願いいたします。

藤森 以前にも説明させていただいた内容なので、簡潔に説明させていただきます。MLで資料を2点配布させていただきましたので、それに基づいて報告させていただきます。まず縦長の資料、「危険」等について（3頁、以下「藤森資料1」）をご覧ください。労働安全衛生法は、第1条に定められているとおり労働災害を防止することが目的であり、その手段として3つ挙げられていますが、その中の一つが「危害防止基準の確立」であり、これによって労働災害の防止を図ることとされています。「危険」の「危」、そして「健康障害」などの「害」、これらを合わせて「危害」とし、その防止を図ることが昭和47年制定の安衛法の大きな特徴です。安衛法以前の労働基準法においては、その辺りについてははっきり規定はされていませんでした。安衛法上の規定の名宛人は大半が事業者ですから、これに基づいて事業者が講ずべき措置として危険を防止することが重要とされています。最終的な目的は、結果としての労働災害の防止にあるわけですが、「安全」の反対語は「事故」ではなく「危険」であり、これを防止するわけです。

そのような観点から藤森資料1をご覧くださいと、安衛法上「危険」に関しては、大きくはこのように区分されています。条文でいうと第20条以下の規定です。現場では様々な労働災害の要因があり、一般的には、人、物・環境、作業、管理という切り口によって分類がなされています。資料1の1枚目に記載したとおり、「1、機械的危険」「2、化学的危険」・・・と、6まで列挙しています。2枚目には、その内容を図示していますが、「1 設備、原材料による危険防止措置（法第20条）」、「2 作業方法・場所による危険防止措置（法第21条）」という書き方をしています。名宛人は事業者であり、事業者がこのような措置を講じなければなりません。「3 設備、原材料による健康障害防止の措置（法第22条）」は危害の中でも、健康障「害」に対処するためのものですが、設備や原材料が前頁の1や2の各要因と同様、危険要因とされています。このような切り口から、現場では機械的・物理的要因や化学的要因ほか各職場に存在する危険に対し、2枚目の図1、「機械的・物理的要因」の上を書いたとおり、「機械、器具その他の設備による危険（1号）」といった規定が設けられています。このように、先ほど指摘した「人、物・環境、作業、管理」という各切り口ごとに、事業者として講じなければならない危険防止措置が規定されています。

資料1枚目に戻っていただきますが、では具体的に危険とはいったいどういうものが問題となってきます。それはすなわち事業者が講ずべき措置の具体的内容につながってきますが、1枚目に記載したとおり労働安全衛生規則（安衛則）に具体的に規定されています。安衛則は非常に膨大な条文数で、規定されている危険の内容も様々です。

三柴 法解釈グループの方に少々橋渡しをしたいと思います。鎌田・田中両先生がまとめられたペーパーの中でも触れられているとおり、現場の労働基準監督官が安衛法に基づいて現場を監督する際に、たとえばこの工場のこの状況は危険だからということで、法令を適用して行政権を発動し、災害が発生したような場合には検察に送致したりもします。現場サイドとしては、監督官がどのような場面で強権を発動するかが気になるわけです。法令を適用する側は「危険が生ずるおそれ」あるいは「危険を及ぼすおそれ」などと書かれているため、それを適用しますが、現場の事業者からすると表現があいまい過ぎて分からないという不安・不満が出てきます。危険なんてものは、結局は判断する監督官の主観なのではないか、というように思えてしまいます。実際にそれが原因で揉めた事案もあります。法令は、どのような事態が危険なのかを一律に定めているから、それに抵触するようであれば強権を発動されてもやむを得ない、という趣旨の判決が下されたりします。では、現場ではどうなのか、それを今後は法解釈論として「危険」というものをどう理解していくべきかについて、行政実務経験豊富な藤森先生からお話しいただいているわけです。

中断させてしまって申し訳ありません、引き続きよろしくお願いたします。

藤森 はい、ではもう一つの横長の資料、「「危険」の内容（労働安全衛生規則）（例）」（2頁、以下「藤森資料2」）をご参照ください。現場で危険要因の切り口が色々だということは先ほどお話ししたとおりですが、では「危険」が現にあるのかないのか、何を以て危険と判断するのかです。現場に赴いて安衛則を中心とする規定を適用するわけですが、資料2をご覧いただければお分かりの通り、「危険を及ぼすおそれのあるとき」、「危険が生ずるおそれのあるもの」あるいは「・・・危険が生ずるおそれのある場所」、「危険を及ぼすおそれのない方法」、「危険が予想される時」などといった文言で規定されています。では、これらに該当するか否かを現場でどう判断するかです。これらの条文は、違反に対して刑罰が予定されていますから、明確な構成要件でなければなりません、「労働者に危険を及ぼすおそれのある」か否か等は、いわば開かれた構成要件のような規定になっています。そこで、名宛人たる事業者にとって、各条項に該当するか否かは非常に重要な点ですから、通達という形で具体化されます。資料2の一覧表をご覧いただくと、「通達」という欄があります（資料2は表題にもありますように、あくまで（例）であって、全部列挙しているわけではなく、代表的なものだけを拾い上げてたものです）。通達欄をごらんいただければお分かりのように、ここに挙げたほとんどの条文に関して、通達による具体化がなされ、ひとつの拠り所となっています。現場の監督官としては、このほか経験に基づく同種事例、事業所ごとに異なる諸般の事情など様々な事情を踏まえ、名宛人たる事業者に対して行政指導、是正勧告などを実施し、急迫のおそれがある場合には使用停止等命令という形でなされる場合もあります。

1枚目の上から4番目に安衛則第432条、「はい作業」に関する規定を挙げています。ここでいう“はい”というのは、物を積んでいる状態のことで、荷崩れなどによる災害を防止するためにこの規定が設けられています。同条にいう「危険」とは、通達によると「はいが著しく傾いている場合、袋物のはいの高

さが3mを超える場合等」を指しています。第432条の規定は、「事業者は、はいの崩壊又は荷の落下により労働者に危険を及ぼすおそれのあるときは、当該はいについて、ロープで縛り、網を張り、くい止めを施し、はい替えを行なう等当該危険を防止するための措置を講じなければならない。」とされています。ロープで縛るとか、網を張るとか、ある程度の内容は書かれていますが、やはり実際の現場ではもっと込み入ったケースもあるわけですから、「労働者に危険を及ぼすおそれのあるとき」に該当するの否か疑問が生じる場合もあります。これに対し、ヒヤリハットや過去の災害事例なども踏まえて通達が出され、そこには資料2にも書いたように「はいが著しく傾いている場合」、「袋物のはいの高さが3mを超える場合」などと定められているわけです。現場ではこれが一つの拠り所となり、事業者に対する指導・監督がなされ、監督官の判断で急迫性があるとなれば、使用停止等命令を出すこともあります。

次いで、資料2の2枚目に安衛則第518条の規定と裁判例を記載しました。高い場所で作業する場合に、墜落により労働者に危険を及ぼすおそれのあるときは、所定の措置を講じなければならないとする規定です。まず、作業床の設置が義務付けられ、それが著しく困難である場合には防網（ネット）を張ったり墜落制止用器具を使用させたり等の措置を講じなければなりません。この条文も「労働者に危険を及ぼすおそれのあるとき」という表現になっていますが、これについて引き合いに出される裁判例があります。資料2の2枚目、「※「危険」に係る裁判例」として広島簡裁の昭和56年判決を掲載しました。あわせて根拠条文となる安衛法第21条第2項および安衛則第518条第1項も引用しましたのでご参照ください。作業が危険要因となることを想定した条文です。この裁判で事業者側は〈主張〉に記載したとおりの主張を行いました。いわく、

「労働安全衛生法21条、同規則518条は、高さが2メートル以上という要件以外に墜落により労働者に危険が及ぼすおそれがあることをも要件としているから当然に具体的な危険の存在を必要としていると解すべきで、具体的に落下場所の模様、高度、当該労働者の年齢技量等を総合のうえ判断して墜落により労働者に危険が及ぶおそれがある場合でなければ事業者に安全措置義務を認めるべきでなく」

という内容です。これに対して、判決は以下のように判示しました。

「労働安全衛生法規の定めは、労働災害の危険性をあらかじめ除去し軽減させ又は危険が生じないことを直接の目的として、労働災害の危険そのものを事前に個別定型的にとらえ、これに対する災害防止措置の基準を示して、事業者にその安全措置を講じさせ、もって労働者の安全を確保せんとしていると解すべきであるから、右規則518条にいう墜落により労働者に危険が及ぼすおそれという点についてもその蓋然性まで要求されておらず、その可能性が認められることで足りると解するを相当とする。」

この判決は先ほども言いましたようによく引き合いに出される判例で、実務上もこれをベースにして対処しているところですが、繰り返しになりますが、こういうことも踏まえまして、監督官はこのような法令、通達、同種事例などを参照しながら現場において判断するということになります。

三柴 ありがとうございます。藤森先生が挙げてくださった広島簡裁の判例ですが、簡単に言えば法令がこういうのが危ないと決めている以上、遵守しなければいけない、現場サイドで“法令に書いてあるけれども実際は危険じゃないから大丈夫だろう”などと勝手に放置してはいけない、ということです。法令に危険と書かれている以上、危険なわけだからその通り遵守せよ、ということを言っている判例です。ただ、これは事件化して揉めてしまった後の後始末の論理であって、藤森先生が最後に言われたように、現



場の監督官の仕事となると、やはり嗅覚を働かせて経験則上危険の有無を判断しているわけです。

藤森 その通りです。そこは繰り返しになりますが、むろん法令や通達は踏まえたうえで、監督官各人の経験則や同種事例、あるいは事業場の関係者に事情聴取などをして、ヒヤリハットの事例なども勘案したうえで、最終的に監督官の判断がなされることもあろうかと思えます。

三柴 そうすると、安全衛生に限らず労働監督行政全般に及ぶ共通の課題だと思うのですが、たとえば現場の事業場でしばしば見聞きする不満について、ベテランの監督官で機微が分かっている人であれば話が通じるのに対し、若手の監督官ほど杓子定規な運用ゆえに正直“ウザい”、といったように人間の判断に委ねるとなると結局は判断する人次第ということになってしまっていて、監督官が気の利いた人かどうかによって現場が変わってしまいます。そうであるならば、ルールの内容は何かということについて法令で詳細部分に至るまで網の目張って決めてくれた方が、現場としては動きやすいわけです。もちろん、それでいいかどうか一律に答えが出る問題ではありませんが、藤森先生ご自身は安衛法上の危険のおそれなどといった問題に関する行政権の発動のような課題に対して、やはり人材を育てて嗅覚が働くようにすべきなのか、それともルールを精緻に定めていく方向がいいのか、もちろん事柄にもよるとは思うのですが、どのようにお考えでしょうか。

藤森 私個人の見解としては、ルールに則って運用するべきというのが基本にあります。その上で、先ほども言いましたように経験則や同種事例の参照なども大切です。たとえば使用停止等命令のような事案になると、急迫すなわち差し迫った危険という要件が加わってくる重大な行政処分ですので、厳格な法令の要件のもとになされるべきでしょう。是正勧告や指導票ということであれば、違反は確かにしているけれども、将来的に二度と繰り返さないようにという視点から監督官のある程度の裁量が認められるべきと考えています。ただ前提として、行政内部の処理基準というものがありますので、それを踏まえたうえで、監督官によっては是正勧告を出さない場合もあります。指導票ということになると、ランク的には少々ソフトなものですが、これに案外意味がありまして、有能な監督官が指導票に書く内容は非常に含蓄があつたりします。

今「危険」についてお話ししたところですが、安衛法の中には、ご承知の通りリスクアセスメントの規定があります。そのリスクアセスメントの“リスク”すなわち危険ですが、これを調査する措置のことで、これは言わば危険の先取りになるわけです。これまでの安衛法は危険の後追いが中心だったわけですが、リスクアセスメント制度の創設によって、危険の先取りをすることで、危険性や有害性を調査しその結果に基づいて事業者が一步先のことに対処する仕組みとなりました。条文上は努力義務規定となっていますが、危険の概念を確定する際には、そのような先取りの側面も加味しなければならないと思います。

三柴 ありがとうございます。藤森先生のおっしゃる危険性と有害性の意味についてですが、いろいろな説明ができると思います。基本的には有害性といった場合、化学物質の持っている毒性を中心としたもので、発がん性であつたりDNAへの悪影響があつたりするものを中心になります。危険性というと、爆発性などといったように、目に見て分かり易い危険が想定されているものと理解しています。藤森先

生のイメージとしてはいかがでしょうか。

藤森 危険性といった場合、広い意味では健康障害なども含みます。まず「危害」といった場合の「害」は旧来からの有害物質ですが、最近問題になっているメンタルヘルスの問題なども含め健康障害のことを言います。ですから、危害といった場合、危険性+健康障害といったように、広い捉え方になると思います。危険性については、先ほど資料1でお話ししたとおり、事故というものは結果であって、そこに至るまでの職場に存在する様々な切り口の危険要因に対して、事業者が防止措置を講じることが求められるわけですから、ご指摘のようにある程度目に見えるという部分もあるでしょう。資料1掲載の図でご覧いただくと分かります。

三柴 ありがとうございます。他の先生方からご意見・ご質問ございますでしょうか。

角田 特に藤森資料1の図説は非常に適切に整理されていまして、貴重なご報告ありがとうございました。藤森資料1の1枚目に「5 行動危険(24条)」の記載があり、「労働者の作業行動から生ずる労働災害」とありますが、これについてどのような解釈になるのかということです。大きく分けて2つあると思われませんが、一つはいわゆる不安全行動で、たとえば職場で不用意に駆け出してつまずいて転倒するといった類の労働災害ですね。もう一つが、重量物を持ち運ぶことによって腰痛になってしまったという災害も含まれるのかと思うのですが、その辺りについて安衛則の関連規定がなかったので、作業行動というものがどういう場合に規制対象となっているのか、お伺いしたいと思います。

藤森 先ほど述べましたように、一般的には人、物、作業、管理という切り口があるのですが、一つの環境の中でお互い密接に関連しています。不安全行動は労働災害の原因の9割以上を占めていると言われていますが、重要なのはなぜそういう不安全行動を起こしたのか、その背後にある原因です。暗いから、狭いから、あるいは労働時間の長さといった要因も関連してきますので、単純に労働者の不注意だけが原因ということにはならないと思います。そうなってくると、労働者がルールを守らなかった、作業手順を守らなかった、そういったこともこの範疇から出てくるでしょう。ですから、第24条違反を指摘するというのは他の条文の場合と比べると難しいものがあります。「作業行動」という書き方にはなっていますが、背後にはやはり環境面、設備面あるいは教育面等の要因があるわけですから、多方面から判断していく必要があると思います。監督行政の現場では、事業者といろいろやり取りしていく中で、こういう問題は背景事情も含めて監督することが重要で。

たしかに安衛則の中にこうした問題に対する明確な規定はありませんが、一つの規則で作るのはなかなか難しいものがあるという理由もあると思います。たとえば振動障害ですが、作業方法や作業手順など様々な原因が折り重なっているのです。振動障害のみを対象とした予防規則はないわけですが、騒音だけの予防規則もありません。というわけで、それひとつだけで予防や解決を図ることのできる規則というものはないし、なかなか難しいところがあると思います。

角田 ありがとうございました。



三柴 他にいかがでしょうか。

原 中心的な論点からやや外れた質問で恐縮ですが、安衛則には危険の概念以外にも曖昧な用語や解釈を必要とする概念がありまして、たとえば第518条は第1項で「墜落により労働者に危険を及ぼすおそれ」を定める一方、第2項において「作業床を設けることが困難なときは」との規定があります。ちょうど私の担当条文なのですが、ここでいう「困難なとき」というのは現場ではどう判断されるのでしょうか。

藤森 作業床に限定して言うと、原則として高い所で作業をするための「作業床」、これがなければ墜落しますから、まず作業床の設置が義務付けられます。ところが物理的に困難な場合、つまり具体的に言えば、建築現場などで足場（これも一種の作業床です）を組めない場合があります。もう一つありがちなのが、「隙間」の問題、つまり足場の内側に隙間がある場合、作業の性質上内側にそういうものを設置するのが困難な場合があります。そういう場合には防網（ネット）を張ったり、安全帯を使用することになります。一次的な措置としては、やはり作業床を設置する必要がありますが、「困難」というのはそういうことが一例として挙げられます。やはり個別的にみて技術上困難な場合というのがありますから、例外は簡単には認められませんが、通達等でも定められています。

原 どうもありがとうございました。

玉泉 安衛則第518条において作業床を設けるのが困難な場合というのは、たとえば木の上に登って枝落ちをする、あるいは鉄塔に登る、高圧線の電路の点検をする、あるいは崖の作業で下から組むことができずに上からロープを垂らして作業をせざるを得ない、などといった場合は足場を下から組むことはできませんので、そういうケースがこの条文の文言の適用対象となります。

原 ありがとうございます。

三柴 法律家的な関心になりますが、今のお話は主に技術的な制約や障害がある場合のお話ですね。要するに、手間がかかる、あるいはお金がないからとか、そういった要因で困難ないし不可能という事態があり得るということです。現場というのは、その辺りの複合ではないかと思います。

玉泉 典型的なのは、たとえば5分や10分といった短時間で建物の2階の窓を拭く作業です。このような場合にわざわざ足場を組ませるのは酷ですね。こういう場合には梯子を使い、安全帯を使いましょうということになります。あるいは柱上作業といって電柱の上で行う作業がありますが、柱上安全帯というものを使って作業をします。これも短時間の作業で、しかも場所が次々に変わっていきますので、各電柱ごとに足場を組むのは無理ですね。そうなると、必ずしも足場や作業床を設置する必要はなく、安全帯をつかえばOKです、ということになるわけです。時間がかかる場合、あるいは最近では高所作業ありますので、1日借りても5万円程度ですから、命よりは安いということで、最近ではよほどのことでもなければ柱上安全帯ではダメということになります。時代とともに変わってきていると思います。

三柴 アメリカでも、OSHA（米労働安全衛生法）が危害防止基準をつくる時に、コストとベネフィットの分析が求められ、コストパフォーマンスの原則がありました。わざわざお金や手間のかかる方法を基準にしてはならないという原則があります。アメリカの場合、そういう経済観念は強固ですから、政策を形成する際にもそうなるのは頷けます。日本の場合、基準をたてる時に、おそらくあまり経済原則は・・・まあ、公労使の意見を反映させる以上は使用者側の意見も聴くという意味では勘案されはしますが、ある程度は綺麗事も書いたうえで現場の運用に任せているという側面があると思います。私もその辺は関心があったところです。

原 要するに安衛則第518条第2項の作業床を設けることが「困難なとき」というのは、作業床を設けることが「適切ではない」というように読み替えることも可能でしょうか。

玉泉 「適切ではない」というより、やはり困難すなわち物理的に難しいという意味です。

藤森 作業の性質上、困難ということです。

原 可能であれば作業床がまず第一に出てくる、ということですね。

藤森 その通りです。リスクアセスメントにも通じることですが、やはり物の順番です。以前の会合でライオンの図でたとえ話をしましたが、まず危ないものや怖いものは失くしてしまうということで、本質的な安全化から始まって、次に工学的対策、その次にソフトな管理的対策という順番は、崩してはいけないのが原則です。そういう順番を考慮した上で、作業の性質上困難かどうかを考慮されるということです。

原 どうもありがとうございました。

三柴 では藤森先生のご報告はここまでとさせていただきます。

（※開催要項「4 今後の予定の連絡と調整」、「5 今年度の検討課題」、「6 横断的検討課題の抽出と担当者の決定」をもとに事務連絡）

では、本日はこれにて終了とさせていただきます。

三柴 本日もよろしくお願いいいたします。すでにMLで配布したのですが、Zoom画面にて今回の会議開催要項を画面共有しておりますが、今回はこれにしたがって議事を進めていきたいと思っております。前回もお伝えしたところですが、私の方から今年度の調査研究方針について、あらためてお伝えいたします。まず、法学・行政学系の先生には、逐条解説を継続していただきたいということです。新規に参加された先生方におかれてましては、それぞれご担当の条文についてお伝えしているので、それについて初年度の報告内容を参考にして逐条解説を進めていただきたいと思っております。本日中にPDFファイルで初年度の報告書をお送りします。そこに掲載された分担報告書を参照しながら執筆してください。また、そこには原さん作成にかかる初年度の議事録も全部掲載していますので、分担報告書だけではどのようにしたらいいのか分からないという場合には、議事録を確認していただければと思います。PDFファイルゆえに、文書内でキーワード検索ができます。知りたいことについて議事録等で検索をかければ、すぐに行き着くと思っておりますので活用してください。分担報告書の作成に際して、項目立ては私の分担報告書に従ってください。それがまだ徹底できていなかった部分もありますので、この点くれぐれもよろしくお願いいいたします。特に新規にご参加の先生方は、私の分担報告書の項目立てについては、先にコピーペーストした上で、その間を埋める形で執筆していただいた方が便利かと思っております。

次に、今年度にやるべきこととしては、横断的課題の検討です。すでに森先生が初年度に法定健診制度という横断的課題について、その概要と改善のための提案を示してくださったのですが、要は逐条的な調査をまたぐような横断的課題については、あらためて担当者を決めたいうえで、より広く検討していこうというのが今年度の重要な課題になります。この点についても本日、先生方に審議していただきたいと思っております。

こうした作業を進めるにあたっての基本原則について、特に法学系・行政学系の先生方にあらためてお願いいいたるところなのですが、事務系・文系の方が知らない用語については、しつこいくらい解説をつけていただきたいということです。たとえば、クレーンとは何か、デリックとはどう違うか、など技術系の方にとっては当たり前のことであっても、事務系文系の方には分からないわけです。素人目線で分かりにくいだろうと思われる用語には、ベタベタと解説を付けてください。専門家だと当たり前のように用いている言葉も、素人や分野違いの人には当たり前ではありません。それらをていねいに解説する本を作りたいと思っています。分量は心配しないでください。通常、出版する原稿の執筆に際しては字数制限がかけられ、書きたいことがあってもていねいな解説ができないこともしばしばですが、本プロジェクトにおいてはその点は心配しないでください。また、図と表を多用してください。とにかく文字だけが並んでいる状態は避けてください。肝心なのはイメージが伝わりやすい本だということです。たとえて言うなら、医学書で図解の本がよく出ていますが、そういう類の本をイメージするような勢いで書いてください。私の分担報告書でも、末尾の方にイラストや写真を相当数掲載しています。

また、これも再度強調したいのですが、法学者等の先生方におかれましては、研究班の中に詳しい先生がご参加になっているのだから、ML等を活用して質問をしていただきたいということです。もし研究班の先生だけでは手に余るという問題があれば、研究班の先生や私からの紹介で、その問題に詳しい人がお答えできるようにします。今のお話との関連で、研究班以外の方にもインタビューを行っていただければと思います。初年度には石崎先生と南先生がすでに実施されています。石崎先生主導の下、安全衛生コンサルタント協会の関係者の方にインタビューを行っておられます。他の先生方も同様に行ってほしいということです。ともかくこのようにして、現場に詳しい方の声を拾ってください。

今年度は、せっかくご参画いただいている先生方全員に、それぞれの知識を披露していただこうと思っております。たとえば角田先生は労働安全コンサルタントとして日頃から現場をご覧になっておられ、玉泉先生ほか行政実務の先生方も同様です。なので、ご自身の目に見えている景色を語っていただこうと思っておりますが、“このテーマについてはこの人に聞いてみよう”ということがあれば、研究班のメンバーであるか否かを問わずにインタビューしてください。

このプロジェクトでは、「適用の実際」を示すことが重要なコンセプトになります。条文をただそのまま解説するのではなく、その条文が現場でどのように使われているのかを明らかにして、現場のリアリズムを描くという趣旨でプロジェクトを進めていきます。そのため、適用の実際についてはしつこくいろいろ調べて書いていきます。初年度に、藤森先生と玉泉先生に安衛法のどの条文がどの政省令と関わっているか、また現場ではどの程度重視されているか、一覧表にまとめていただきました。さらに、関連している政省令の中で重要なものは何かを表の中で示していただいたところです。安衛法の関連政省令は膨大な数になり、これらを全部扱っていたら時間も人手も足りません。なので、法律条文に特に関連性が深いもの、実務的に重要なものをピックアップしていただいたわけです。その作業を踏まえ、今年度は全国の監督官や元監督官の方に向けて、あらためて適用の実際について何らかの調査をしたいと思っております。これをどう実施するかについては、先生方にあらためてご相談したいと思います。法律条文を最初から順に並べて、その重要度や関係政省令についてインタビューし、その際に藤森・玉泉両先生の選択をデフォルトとして示すという方法も、あくまで仮定ですがあり得ます。また、もっと別な角度からの調べ方もできるかもしれません。その辺後ほどまたアイデアをいただければと思います。あるいは、両先生作成の一覧表をもとにして、アンケートによる集合調査という方法ではなく、お話を聴くに値する人を両先生にご紹介いただき、その方にインタビューを行うという方法もあり得ます。いずれにせよ、現場の行政実務に詳しい方に何らかの形で安衛法の現場運用についてインタビューや調査を行うことを考えています。後ほどこの点についてのアイデアをきかせていただきたいと思います。

初年度に社会調査を実施しまして、安衛法と安全衛生について企業関係者がどう認識しているか、特に経営者がどう考えているかを調査したところ、けっこう興味深い結果となりました。これを本省の安全衛生部の方にお見せしたところ、イギリスでも似たような調査を実施したら面白いのではないかと指摘されたので、予算があれば実際にやってみようかとも思っています。今年度はただ座りっぱなしの会議というだけではなく、各先生方が必ず1回はご自身の知識を披露していただく機会を設けます。つまり、初年度においては報告書を書かれる先生は中間報告をされましたが、それ以外はベテランの先生のご発言がメインで、当初はそれでもよかったのですが、せっかくお集まりいただいているのに、文章を書かない先生が何もしゃべらないという経緯もありましたので、その点は改めたいと思います。

開催要項の2に移ります。前回も強調したところですが報告書の執筆者におかれましては、提出期限が10月末日厳守となりますことをご銘記ください。報告書作成にあたっては、新規の報告書はそのまま執筆していただければいいのですが、初年度の報告書を改訂、すなわち加筆・修正する場合には、開催要項にも書きましたように、実質的に内容を改訂したり加筆したりする部分には下線を引いてください。これは後日要約を作成する際の効率化を図るためです。加筆した内容のうち、要約に加えてほしい部分については、下線を引いていただきたいと思いますということです。些末な表現の変更くらいでしたらかまいません。そうではなく、内容的に加筆したという箇所には下線を引いてください。削除した内容の部分については、実際に削除されたらわからなくなりますので、削除した部分にポインターをあててコメントをつ



てください。“この部分は削りました”ということをコメントで示してください。ただしこの点も、私が作成する要約において削除してほしい部分に限ります。ちょっとした表現の修正程度であればこのような扱いをしなくても構いません。

次に、今年度は横断的的検討をお願いしますが、その分担報告書は逐条解説とは別途に作成してください。これも私の方でできる限り形式に関してリードするようにします。私の報告書の執筆過程をMLで先生方に共有していただけるようにしますので、それを参考にして項目立てや表題の決定をしてください。そうしないと、各先生が報告書に付すタイトルがバラバラになってしまう可能性もありますので。なので、私ができるだけリードしますので、それを参考にして、一定の形式で執筆していただくようお願いいたします。

さて、次にいよいよ本日のメインイベントになります。メインイベントとしては開催要項の3～5がこれに当たりますが、まず唐澤先生から初年度の石崎先生の報告書に対してコメントをいただくということから始めます。手順としては、石崎先生の要約を私が読み上げます。その後、石崎先生から補足があればコメントをいただき、その後唐澤先生に準備していただいたコメントをいただくという順序で進めたいと思います。

画面に私の報告書（※）が映ってると思いますが、いかがでしょうか。では、読み上げます（内容は以下の枠内参照）。

※労働安全衛生法の改正に向けた法学的視点からの調査研究・令和元年度 研究報告書

#### 7 石崎報告

石崎報告は、法第65条及び第65条の2について詳説している。より正確には、両条が定める作業環境管理をめぐる制度の変遷を、背景となった災害や、当該制度を安全配慮義務の内容と認めた判例、最近の坑内作業場への展開の動きなどを含め、詳細に論じている。それを端的に言えば、現実的な運用可能性と管理の精度ないし実効性の向上を両立させようとする努力の経過だったといえる。すなわち、制度的には、作業場ごとに異なる作業環境に適合した環境測定デザインのデザインからはじめ、測定、評価、対応策までの包括的なプロセスの構築を模索する過程であり、技術的には、時間や空間ごとにばらつきがある有害物の濃度の的確な捕捉を模索する過程だった。安衛法とは別に単独立法として制定され、主に作業環境測定を担当する専門家や専門機関の認定等について定めた作業環境測定法については、その前後の関連条約（職業がん条約や作業環境測定条約）の採択、作業環境測定の専門性の高さがドライブとなったこと、単独立法とすることで社会的な認識の喚起が図られていたことなどが示されている（ただし、作業環境測定条約は、同法上の作業環境評価の仕組みに大きく影響した経過がある）。判例は、災害発生後の賠償責任論として、使用者に、作業環境管理の包括的なプロセスの実施について最善の努力を講じる義務があると判断することで、制度や技術の展開を後押ししてきたことが窺われる。また、告示として発せられてきた作業環境の測定や評価に関する基準には、強い法的効力が認められてきたことも示されている。

その他、石崎報告書からは、以下の事柄が窺われる。

大阪の印刷工場で生じた胆管がん問題に象徴されるように、化学物質管理の法政策は、古くて新しい、人の命や健康に関わる規制科学の重要問題である。現在、約7万種類の化学物質が職場で取り扱われていると言われる。我々の生活は、現に多くの化学物質に支えられている以上、それらの製造や取扱いを全て禁止するのは現実的でない一方、実効的な規制のありようは、知識、技術、コストなど、さ

まざまな限界との関係で、国内外で長年の難題だった。これは、いかに産業の高度化が進んでも、労働者らが化学物質に接触する（ばく露する）機会がある限り、継続する問題である。化学物質管理に関する労働安全衛生関係規制は、製造業者らによる新たな物質の危険有害性の調査と行政への届出、危険有害性の大きさによる規制の段階化（製造禁止から危険有害性の自主的な調査等の推奨まで）を基本として、事業者による技術的措置、製造業者らによる危険有害性情報の事業者への伝達、作業場の空間にある有害物の測定、評価と有効な対策の基準化、専門家や専門機関の養成など、多様な主体による多面的な措置を、強制から誘導、権限の設定まで、さまざまな手法で図ってきた。しかし、新規化学物質は増加の一途を辿るし、既存化学物質の危険有害性も全て明らかではないし、たとえ明らかであっても適切な測定にはさまざまな障害がある。そうした中で、アスベスト訴訟のように、国の規制権限の不行使が問われる訴訟や、化学物質被害に遭った労働者が事業者や製造者の過失責任を問う訴訟も生じている。そして、化学物質の有害性について情報や取扱い経験を持つこと等を根拠に元請けの過失責任を認める例（みくに工業事件・長野地判平成3・3・7 労判588号64頁）や、使用者には、行政が公表した職場空間の有害物質濃度の基準を遵守するのみではなく、国際的な環境基準等に準拠して作業環境を整備する不法行為法上の注意義務があったのに怠ったため労働者に職業病を発症させたとして賠償責任を認めた例（日本化学工業事件・東京地判昭和56・9・28 判時1017号34頁）、やはり、使用者に、法定の作業環境管理のみではなく、個人サンプラー（個々人に取り付ける化学物質の測定器）の活用を含め、測定から対策に至る現場実態に合った管理を行う安全配慮義務があったのに怠ったため労働者の有機溶剤中毒を招いたとして賠償責任を認めた例（内外ゴム事件・神戸地判平成2・12・27 労判596号69頁）など、直接の使用者ほかの関係者にやや結果責任的な賠償責任を課す例が散見される。つまり、化学物質管理に関する安衛法の基準は、過失の判断基準になり得ないほど不完全な状況にある。そこで、安全衛生法の政策担当者は、EUのように、事業場で取り扱われる全ての化学物質について、事業者リスクアセスメント（危険有害性の調査）の義務づけを図ってきたが、罪刑法定主義を充たすほど要件を定義できないとの批判のほか、危険有害性が明らかでない物質について事業者にも過重な負担を課し得ない等の批判により、ごく一部の物質を除き、実現していない。これは、科学者と制度論者が協働して取り組むべき課題である。

三柴 以上のような報告を石崎先生からいただいたものと受け止めております。石崎先生、補足があればよろしくお願ひします。

石崎 補足というほどではないのですが、三柴先生も言及されていたように、この辺りをまとめていて感じたこととしては、やはり技術の発展とともに法制度が発展してゆく様子がリアルに出ています。現時点でできないことはできないということで仕方ないにしても、可能な範囲で規制していこうという流れがあり、それが現在進行形で続いているといえます。また、作業環境測定の結果が悪かったこと自体を処罰するのではなく、改善を促していく形になっているというのが特徴的です。私自身、化学物質をはじめとする理系の感覚がない中で取り組んだことなので、調査にはいろいろと手間取ったのですが、畠中先生、唐澤先生、藤森先生から資料や情報をいただいて昨年度は一応まとめるに至りました。今年度はもう少し作業場そのものの説明も付記したものと考えているところです。



三柴 ありがとうございます。制度というものは、科学的に白黒つけられずハッキリした結論が出ない場合であっても、どこかでけじめをつけて統制を図っていかないと始まりません。科学的には“ここまで判明している”“ここまでは可能である”といっても、では制度はどうするのかについて、コンセンサスで決めていくものといえますが、なかなか難しいところがあります。このテーマは世間一般には注目や関心を集めているとはいえませんが、もっと注目されるべき興味深いテーマだと思いますし、ぜひ掘り下げて検討すべきかと思います。

では、いよいよ唐澤先生にお話をお願いしたいと思います。Zoom画面に唐澤先生の資料を共有しますので、しばしお待ちください。2点ありまして、一つは「石崎先生への唐沢コメント 2020年5月8日」（以下「唐澤資料1」）、もう一つは「統括報告書用三柴メモにおける「石崎分担報告書」に関する三柴コメントの中心部分に関する唐沢コメントについて」（以下「唐澤資料2」）です。

唐沢 では、始めさせていただきます。石崎先生は大変詳細かつ正確にまとめていただきまして、その点は大変感服しております。私のコメントは些細なことなので簡単に申し上げます。まず唐澤資料1には表を記載しましたが、その2段目に「評価手法（項目）」「評価基準」「評価内容」との項目を設けました。そのうち、「評価手法（項目）」の箇所「作業環境測定」の後にカッコ書きで、「（個人サンプリング法によるものを含む。）」と追記してはどうかというコメントをいたしました。令和2年1月27日に個人サンプリング法を選択的に導入することができるようにするため、労働安全衛生関係法令の改正がなされ、令和3年4月1日に施行されることになっています。やや誤解があるのかもしれませんが、個人サンプリング法というのは、労働者のばく露状況を測定するのではなく、そこに厚労省の資料から図を引用しておりますが、このように個人サンプラーを装着した労働者が実際にばく露される呼吸域における有害物の気中濃度を、より実態に即して測定するという、作業環境測定の一手法です。この点は正確に書いていただいた方がよろしいかと思います。

次の欄で赤字でコメントさせていただいたのは、作業管理の箇所です。すなわち、「作業方法の適切な管理や個人サンプリング法によるばく露濃度測定」ということにさせていただき、カッコ書きで「（作業方法等によって高濃度ばく露のおそれがある場合やばく露限界値が極めて低い有害な物質によるばく露を低減させる等のためのものである。）」という説明書きを追記させていただきました。作業管理というのは、その事業場で適切な作業標準が定められ、安全衛生面も加味した作業標準が適切である場合には、これを遵守して作業者が作業をする、あるいは指揮監督・指導するということも含まれますので、そのような意味も書いた方がよろしいかと思います。

三柴 今の箇所ですが、もう一度お願いできますか。ただ今のご説明は、唐澤資料1の1頁最後の行から2頁にかけてのものということでよろしいでしょうか。

唐澤 そうです、その部分についての説明です。要するにポイントとしては、「作業方法等によって高濃度ばく露のおそれがある場合やばく露限界値が極めて低い有害な物質によるばく露を低減させる等のため」という点が個人サンプリング法による作業環境測定の主な対象です。この点を明確にさせていただいたということです。

三柴 ありがとうございます。

唐澤 次に「健康管理」の箇所です。これは森先生がお詳しい分野ですが、石崎先生のファイルでは健康管理、健康診断、生理値、そして作業者の健康影響と書かれていますが、生理値については私が赤字で「生理値等の正常値」と付記しました。この言葉が医学的に正確かどうかという問題があるのですが、判断基準の内容の中には、“正常値”というものがあるのではないかということからコメントさせていただきました。

次いで、石崎先生のファイルの15頁に1178通達の話が出てきまして、石崎先生が書かれていることは正しいのですが、アメリカの労働衛生専門官会議（ACGIH）が示した有害な化学物質についてのThreshold Limit Values・・・これを日本語で「抑制限度値」と説明しておいた方がよろしいかと思えます。また同じ個所の後段部分ですが、かつては週48時間だったのですが、現在はACGIHの勧告値は、1日8時間・週40時間労働になっていますので、それを付け加えさせていただきました。

またファイルの17頁にて、アメリカはカリフォルニア大学のブルース・N・エイムス（Bruce N. Ames）教授、この人は発がん性物質のスクリーニング方法として変異原性試験を発明した人で、肩書を正確に表記された方がよろしいかと思えます。ということで、「ブルース・N・エイムス（Bruce N. Ames）教授（当時）博士」とさせていただきます。

ファイル18頁において、「気中濃度に対する規制値であるような」受け取られ方があったという事実はあるのですが、いわゆる抑制濃度についてやや断定的に過ぎる書き方かと思ひまして、「誤った受け取られ方をした面もあった」として、やや表現を和らげました。

以上です。

三柴 いったんここで切らせていただいて、以上の点について石崎先生から何か追コメントがあればお願いいたします。

石崎 特にございませませんが、ていねいに見ていただいて本当にありがとうございました。

三柴 確認させていただきたいのですが、さきほどの生理値等の正常値の趣旨について、もう一度ご説明を重ねていただけますか。

唐澤 実際には我々は人間ドックで検査をして、その際に健診機関が正常値の範囲を示していますが、そういったものと比較して、健康状態が正常なのか異常なのかということアメリカの医師は判断するということです。そういう趣旨がわかるように「生理値等の正常値」というように文言を変えさせていただいた次第です。それ以上の意味はありません。

三柴 ありがとうございます。では、石崎報告に対するコメントは以上とさせていただいて、私の整理に対するコメントをお願いしたいと思います。

唐澤 唐澤資料2の1頁目の枠内に青字で表記させていただきましたが（※内容は下記参照）、これにつ

いてコメントさせていただきます。

(三柴先生の石崎分担報告書についてのコメント中の重要部分)

つまり、化学物質管理に関する安衛法の基準は、過失の判断基準になり得ないほど不完全な状況にある。そこで、安全衛生法の政策担当者は、EUのように、事業場で取り扱われる全ての化学物質について、事業者リスクアセスメント（危険有害性の調査）の義務づけを図ってきたが、罪刑法定主義を充たすほど要件を定義できないとの批判のほか、危険有害性が明らかでない物質について事業者にも過重な負担を課し得ない等の批判により、ごく一部の物質を除き、実現していない。これは、科学者と制度論者が協働して取り組むべき課題である。

まず「○論点1 「罪刑法定主義を充たすほど要件を定義できないとの批判」について」です。この点議論を効率的にするために、「安衛法第五十七条第一項の政令で定める物及び通知対象物について事業者が行うべき調査等」に的を絞りますが、これからの記述は、「第二十八条の二（事業者の行うべき調査等）」にも概ね当てはまるものであろうと私は考えます。

(1)「第五十七条第一項の政令で定める物及び通知対象物について事業者が行うべき調査等」について、刑事上の処罰ができるようにするためには、具体的にどのような内容について調査等を行わなければならないのかが、構成要件的に明確になっている必要があるように考えます。これも議論を簡単にするために、がん原性がある化学物質について調査等をするのであれば、どのような項目について、調査すればよいか、考えられる項目を次に掲げます。これは化学物質の毒性学の教科書に出てくる項目です。

- ① 物理化学的性状
- ② 有害性
  - ・ 一般毒性（急性毒性としての投与された実験動物の50%が死亡する濃度(LD50)等)
  - ・ 慢性毒性
  - ・ 特殊毒性（がん原性、生殖毒性、免疫毒性、催奇形性、神経毒性、血液毒性等）
  - ・ 標的臓器毒性（肺、器官、心臓、肝臓、膵臓、消化器、中枢神経系、皮膚等）
  - ・ 動的毒性（Toxicokinetics: その化学物質が人体内でどのように代謝され、それぞれの毒性が発現していくかを解明する。）
  - ・ 職業上のばく露限界値
  - ・ ・ ・ 等があります。

そして、これらの項目のすべてを調査するには、相当の専門的な知識が必要とされます。これらの項目にはさらに詳細な細分類項目がありますから、構成要件的なものとしてこれらの細目を規定することはかなり困難でしょう。

(2)そこで、ドイツやアメリカ合衆国では、事業者に対して、これらの調査をすることのできる専門的な知識を有する者にこれらの調査を実施させるように求めています。違反には罰則を伴っています。ドイツの場合には「有害物からの保護規則」第6条第9項で、「(9)リスクアセスメントは、専門的な知識を有する者のみが行うものとする。使用者が自ら関連する知識を持っていない場合、使用者は知識のある助言を得なければならない。専門的な知識を有する者は、特に労働安全衛生の専門家及び産業医である。」と規定しています。また、アメリカ合衆国では「Industrial Hygienist」を想定しています。ただし、英国ではこれらの調査（リスクアセスメントの一環としていますが。）にはそれなりの能力が求められるとはしているものの特定の有資格者を想定はしていません。そして、英国安全衛生庁は事業者等のため

の訓練コースを設け、その受講を促進する指導をしています。

(3) それでは、「第五十七条第一項の政令で定める物及び通知対象物について事業者が行うべき調査等」におけるこれらの物について、これらの物理化学的性状、有害性等について、国（厚生労働省又は化学物質に関する関係省庁合同の）がデータベースを構築してそのデータベースから必要な情報を取得した場合は、事業者はこの調査等を行ったものとするのが考えられます。しかし、現状においては各省庁共通の化学物質の危険有害性データベースが不十分ながらありますがとてもこのような役には足りません。中央労働災害防止協会も一定数の化学物質についてモデル SDS (Safety Data Sheet) を公表していますが、やはりこのような役には足りません。しかも、このようなデータベースの作成には高度の能力を有する多数の専門家の協力がなければその構築及び維持管理（科学技術や医学等の発展に沿って維持管理することが求められます。）はできませんから、国がこのようなデータベースを構築している例は、EU そのもの、英国、ドイツ及びアメリカでもこのようなデータベースは EU や国としては作成していないようです。やはりこれらの専門家が活発に活動できる学会等でないとこれらの活動は困難でしょう。

(4) そこで、私の提案としては、これらの調査を一定の専門的知識のある者に実施させることを事業者者に義務付け、その違反には罰則を科することとしてはいかがでしょうか？

次に「○論点 2 日本においては、EU、ドイツ、英国及びアメリカのように、労働者の職業上のばく露限界値を国が法令上規定しておらず、事業者に直接労働者の職業上のばく露限界値を超えたばく露について罰則をもって規制していないことについて。」この論点 2 についても、議論を効率的にするために、特定化学物質障害予防規則（特化則）に限定して記述します。他の特別則においても同じことが言えると思います。

(1) 特化則の規制対象物質の空気中の濃度の限界値については、同規則第 7 条第 1 項第 5 号に基づき「特定化学物質障害予防規則に基づく厚生労働大臣が定める性能」の中でこの規制対象物質の濃度の規制基準を規定するという間接的なやり方を取っています。この点は、EU、その加盟国であるドイツ、EU を離脱した英国さらにアメリカ合衆国では、それぞれ、職業上のばく露限界値を法令で規定しています（民間の学会等の公表している技術的情報を参考にしているはずですが、別に法令でこれ等のばく露限界値を規定しています。）。日本も化学物質規制をより分かりやすくするために同様な対応を取ってはどうかと私は提案します。

唐澤資料 1 の 3 頁以下は関連条文ですので、私の意見としては以上です。

三柴 ありがとうございます。この点は、まず森先生に追コメントをいただきたいのですが、森先生のお話しやすい点についてお願いいたします。

森 私が今年度にまとめている内容との関連で、用語の統一や範囲の統一といった問題があります。たとえば、唐澤資料 2 の 1 頁目の「○論点 1」の中で、「特殊毒性」の内容が列挙されていますが、GHS (Globally Harmonized System of Classification and Labelling of Chemicals) という有害性の定義があって、その中にはがん原性、生殖毒性、生殖細胞偏倚原性などといった定まったものが列挙されているので、それと離れた記述をした場合に統一感を欠いてしまっているのかという点がひとつ気になったところです。



唐澤 確かにGHSはありますが、私の資料では毒性に関する教科書を参考にしたものですから、表現は少々解離するかもしれません。場合によっては調整してみたいと思います。

三柴 私も専門外でよく分からないのですが、GHSのアナウンスメントと一般的な化学物質に関する教科書とでは、制度論を論じる際にはやはりGHSを尊重した方がよろしいでしょうか。

森 そうですね。GHSは国連で決まったある意味「条約」のようなものです。日本はそれを批准して、日本国内のSDSの項目もそれに従っています。

唐澤 GHSは未だ勧告であって、条約にはなっていないと思います。

森 確かにそうでした。ただ、日本もそれを批准ではないですが、法律に取り入れるという意思決定はしているものなので・・・

唐澤 はい、森先生のご指摘の趣旨はわかります。私が特に言いたかったのは、構成要件的に化学物質の有害性を調査する内容を全て書き出すとなると、実務的に大変ですということです。

森 本当にその通りだと思います。あと、おそらく産業医業務と関連しているのですが、ドイツではどのような人がリスクアセスメントを実施するかという話の中で、産業医が挙げられています。ヨーロッパの産業医は基本的には専門医なので、日本でいう認定産業医のような人は産業医ではありません。その辺りの背景を考えると、日本で認定産業医制度を前提に化学物質のアセスメントを産業医の職務にすることは無理なので、日本に当てはめる際には注意が必要だと感じたところです。

唐澤 私もドイツの産業医制度をいろいろ調べていましたが、ドイツの産業医はご指摘のように労働医として高い専門性があります。ただドイツの規則では文字面からすると、前述のような規定になっています。

森 ありがとうございます。

三柴 唐澤先生の試案でご提案されている、専門家・専門機関に実施させることを義務付けるというのは大変興味深いと思いました。現にドイツのArbeitssicherheitsgesetz（労働安全法）はそのような定めをしているので、海外の制度とも整合性があるとお聞きしていました。たとえば日本では胆管癌の問題についても、けりのつけ方は産業医を選任していなかったこと、そして衛生委員会を設置していなかったことであって、逆に言えば法令の定めは選任せよ、あるいは設置せよという内容が基本であり、もちろんどういう仕事をさせるべきかは政省令に書かれていますが、罰則適用との関係では、選任・設置ということがメインになってきます。そこを、現にさせる仕事の内容まで処罰の対象にするのであれば、新しい試みのように思います。唐澤先生のお考えは、要するにさせる仕事を明確にする点に、現行の法制度と比してプラスがあるということでしょうか。

唐澤 そうですね、やはり事業者が自分の思い付きだけで化学物質の有害性調査を実施したというだけでは不十分だということを明確にさせた方がいいのではないかと思います。

三柴 そうすると、あまり細かい法令の中身の定め方の話というよりは、専門家を使わないと対応できないのだから、それを上手く促すような制度が必要であるという趣旨ですね。

唐澤 はい、そういうことです。

三柴 日本でも産業医にさせる仕事や衛生管理者等にさせる仕事というのは、安衛則等の政省令で定められていますから、選任してはいるものの所定の仕事をさせていないということで罰則の対象とすることはできます。藤森先生、そうですね

藤森 その通りです。

三柴 ただ先ほども指摘しましたように、こうした違反に対して罰則を適用しようとするれば、運用上難しい問題が生じます。単に選任・設置していないことを処罰するのであれば違反は明確にとらえることができますが、一定の仕事をさせていないということであれば、構成要件との関係でも判断が難しくなります。

森 実は、私のところでもその議論をしなければいけないと思っています。仕事を「させる」ということと、させた仕事のクオリティの問題も含まれています。一方で、専門家にさせるという規定は、仕事のクオリティを担保ができる専門家が存在することが前提ですが、日本はリスクアセスメントを専門家に実施させろといったところで、担保できる専門家が育っていません。また、人材が育つまでに時間がかかります。義務化することと人材養成をすることは、鶏と卵の関係です。人材がないから出来ないとなると、永久に出来ないままになるので、この辺りの問題は日本が先進国の中で最も恥ずべき状態にあるといえます。この問題は、あらゆる場に記載しなければならない問題だと思います。

三柴 私も学会が編集した体系書において安全配慮義務とは何かをテーマに論文を書いた際に、専門家の質を担保することも安全配慮義務の内容だということを書きました。ただそれを法律論として言うためには、労使が、特に労働者が“この人は専門家としてダメだ、替えて欲しい”という要求に使用者が応じる義務だというように構築しないと、法律論になりません。私はともかくそういう立論をしたのですが、全然分かってもらえなくて、法律論者はこういう問題には今のところほとんど関心がないようで、そこを理解してくれたと思えるような方が今のところ見当たりません。人的なクオリティの担保は非常に重要な課題になってきています。特に、対応しなければならない課題が複雑多様化していると思いますが、人を育てようとする、たいていの場合「総論賛成、各論反対」になります。お金もコストもかかるからです。この堂々巡りを何とかしなければなりません。



藤森 一点よろしいでしょうか。ただ今お話いただいたことは、現場でもジレンマを感じていたところ  
です。安衛法第1条に同法の3つの目的が定められていますが、うち一つは「責任体制の明確化」、そし  
て「危害防止基準の確立」です。結局目指すところは「危害防止基準の確立」で、要は事業者として講ず  
べき措置ということになります。現場では、より直接的な問題としては、そういった措置義務に対する違  
反が問題になってくるわけなので、事業者は責任体制の明確化を通じてその枠組みを作らなくてはいけ  
ません。そして、どういう人材を選任しなければならないか、どういうシステムが大切であるか、それと  
関連してどういう人がそれに相応しいか、どういう職務を遂行しなければならないか、が大切になって  
きます。ただ、それらについて罰則をもって臨むには、責任体制の明確化や危害防止基準がハッキリした  
上で、罪刑法定主義の原則に則らなければなりません。選任、適切な職務の遂行、報告、記録の保存とい  
った措置は重要ですが、ではそれらの違反が認められるのか、また、認められるとして刑罰を下すべきか  
という判断は容易ではない場合があります、現場でもその点ジレンマに陥ることがあります。

三柴 ありがとうございます。確かに、法令というものは基本的には強制を前提にしているのです、要件の  
分かり易さが求められます。法律学では「要件」「効果」という表現をしますが、要件がハッキリしてい  
るからこそ、その効果として強制もできるという関係があるわけです。現場論的に、というか本質的には  
当然、人材の質が重要なのですが、それを法制度を用いて実現しようとするのであれば、先ほども申しま  
した通り“労働者の要求に応えたか”、“書類を作成して所轄の行政官庁に提出したか”あるいは“産業医  
の選任届を提出したか”などといったところまでしか規制が出来ません。法制度というのは、実質的な目  
的を達成するためのきっかけ作りにはなりますが、それで必要十分条件というわけにはいきません。法  
制度さえ作ればそれで十分条件を充たすなどといったことは、よほどよくできた危害防止基準のよう  
なものでなければ難しいかと思えます。

ともあれ、唐澤先生には非常に丁寧なご準備をいただきまして、分かり易く有益なお話をいただいた  
と思えます。石崎先生におかれましては、これを踏まえたうえで今年度も調査研究の継続をお願いでき  
ればと思えます。

石崎 承知いたしました。

三柴 では続いて、安衛研の吉川・平岡両先生からご報告いただきたいと思えます。安衛研グループに  
は、両先生を含め初年度に安衛法が制定される直前の災害例の経過について、特に安衛法の素案を練っ  
た労基法研究会に注目しながら執筆していただいたという経緯があります。そこで言いたかったのは何  
か、また今年度はどういう調査に広げていくのか、という点についてお話をいただく予定です。

それでは、お願いいたします。

吉川 昨年度までは今三柴先生のお話にあった調査をしてきましたが、今年度は特定の災害に絞って調  
査をさせていただければと考えています。前年度の報告は今年の2月にさせていただきましたので、ま  
た時間も押しておりますので、まずは今年度に予定している調査研究内容について報告させていただきます。

まず、すでにお送りした「特定の災害からガイドラインが発出されるまでの流れ」（以下「吉川資料」）

を用いて説明させていただきます。本報では、2012年2月7日（火）に岡山県倉敷市内の海底シールドトンネル建設工事に発生した崩壊水没災害を例にとって、同災害からガイドラインが発出されるまでの流れを示したいと思います。「シールドトンネル」というのはあまり馴染みのないものと思われるので、まずこれがどういうものかということから説明させていただきます。

## 工事手順（シールドトンネル部）

きたせんのトンネル工事は、シールド工法によって進められました。ここでは、きたせんのシールド工事について説明いたします。

### シールド工法とは？

シールドマシンと呼ばれる筒状の機械で土の中をゆっくりと掘り進めていく工法です。前方の土砂を削りとりながら、掘った部分が崩れてこないようにマシン内部でセグメント（トンネルの外壁となるブロック）を組み立てていきます。このように、トンネルの壁をつくりながら安全に掘り進めていくトンネル工事方法のことをシールド工法といいます。



シールドマシン

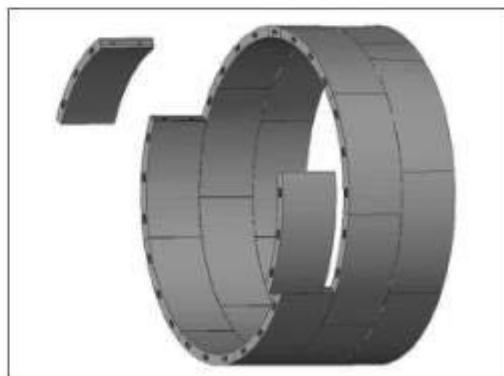

セグメント

（出典：<https://www.shutoko.jp/ss/kitasen/yokokan/construction/work02.html>）

↑これが、シールドマシンと呼ばれるもので、直径が3 mから大きなものでは15 mを超えるような大型のものもあります。これで地盤を掘っていきます。右側のセグメントと呼ばれるものは、鉄筋コンクリートや鋼製のセグメントもあるのですが、一つのリングが複数のパーツで構成されています。そのパーツを“セグメント”と呼びます。図の場合だと、8～9個のセグメントを組み合わせると一つのリングが出来上がります。このリングこそがトンネルになるわけですが、リングを順番に組み合わせることによって、トンネルを構築していくのがシールド工法と呼ばれるものです。

次に事故の概要について説明します。どのような事故であったかについては、我々の災害調査報告書

および厚労省が公表している検討会報告書にも書かれています。吉川資料の4頁にHPのアドレスを掲載しましたので、後ほどご覧いただければと思います。

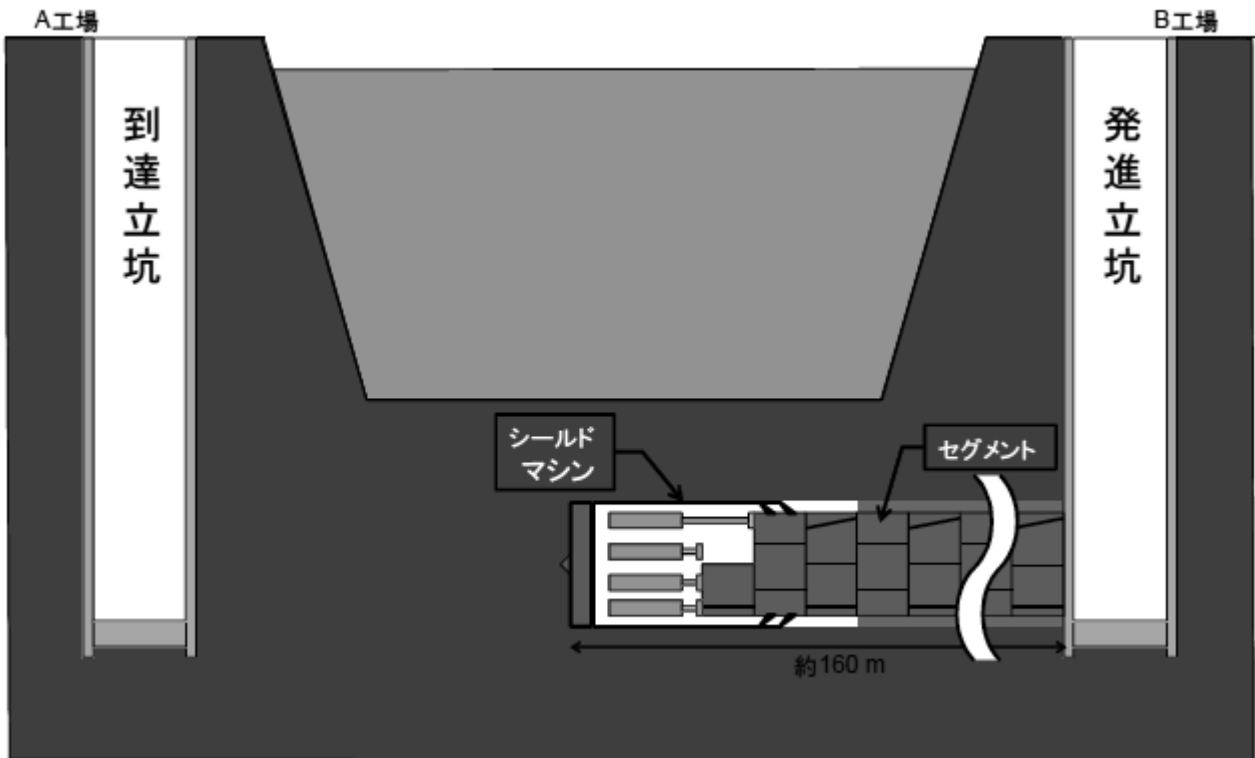

(出典 : <https://www.mhlw.go.jp/file/04-Houdouhappyou-11302000-Roudoukijunkyokuanzeneseibu-Anzenka/0000128236.pdf>)

上図のとおり、岡山県倉敷市の水島港において、図の右側にB工場があり、左側にはA工場がありました。B工場の側には「発進立坑」、つまり縦穴を掘ってそこからシールドマシンで海底地盤を掘進し、先ほど説明したセグメントによってリングを組んでいく工事が行われていました。全長がだいたい800mほどの予定でしたが、事故が起きたのは約160mほど掘り進んだところでした。そこで一つのセグメントが抜け出した結果、坑内に海底の土砂や海水が流入し、坑内の作業員5名が死亡したという事故です。事故が発生したのは2012年2月7日のことです。結果的に5名の作業員が亡くなるという重大な災害だったのですが、事故当日岡山労働局に災害対策本部が設置されました。管轄の倉敷労働基準監督署がすぐに調査を開始しています。翌2月8日には、厚生労働省労働基準局安全衛生部安全課建設安全対策室の主任技術審査官、そして弊所の建設安全研究グループ部長と研究員（吉川）の3名が同災害発生現場に行き災害調査を実施しています。この調査がこれ以降継続していきました。事故から1か月後、厚生労働大臣から労働安全衛生法第96条の2第3項に基づき、弊所の理事長に厚生労働省発基安0307第5号「労働災害の原因の調査のための立入検査の実施について」が発出されています。我々はこれを、「大臣指示」と通称していますが、独法化されて以来、厚労大臣から直接調査の指示を受けるのは、弊所にとって初のことであり、それくらい重大な災害であったということです。この大臣指示を受け、弊所の中にシールドトンネルに詳しい学識経験者等から構成する「岡山県の海底シールドトンネル

建設工事中に発生した水没災害に関する「災害調査委員会」が設置されています。弊所が行なった主な災害調査については、後ほど吉川資料の別表でご報告します。同時に国交省でも協議会が開催されまして、7月23日には、弊所と厚労省もオブザーバーとして参加させていただいた「シールドトンネル施工技術安全向上協議会」から中間報告が公表されています。国交省がこうした動きを見せている以上、厚労省も何もしないわけにはいきませんので、8月6日には、厚生労働省労働基準局安全衛生部安全課長から基安発0806第1号「シールドトンネル施工に当たっての留意事項について」が発出されています。これについても、吉川資料の末尾にHPのアドレスを掲載しました。ここには、調査時の留意事項や設計製造時の留意事項、あるいはセグメントについて、シールドマシンについて、施工時の留意事項、シールドマシンの制御、組立、裏込め注入、避難退避などについての記載があり、これを見てもわかるとおり、一つの災害で一つのガイドラインが出来たわけですけれども、ガイドラインの中には様々な条文が関連してきます。一つの災害を防止しようとするためには、数々の条文が必要になってくるということがわかります。そして、2013年3月29日には中間とりまとめが公表され、同年8月23日、海底地盤に水没していたシールドマシン及び一部セグメントを施工者が海底地盤から地上に引き揚げられています。2014年3月には、「シールドトンネル施工技術安全向上協議会 報告書」がとりまとめられ、同年6月に弊所が「災害調査報告書」を厚生労働省労働基準局安全衛生部長に提出しました。翌2015年6月30日には、厚生労働省労働基準局安全衛生部長がシールドトンネルの施工について知見を有する者を参集して、「シールドトンネルの施工に係る安全対策検討会」を構成し、第1回検討会が開催されています。2016年6月22日には、厚生労働省労働基準局安全衛生部から「シールドトンネルの施工に係る安全対策検討会報告書」が発表されています。これは第1回では終わらず、第2回、第3回と開催されましたが、3回目以降にこの報告書（<https://www.mhlw.go.jp/file/04-Houdouhappyou-11302000-Roudoukijunkyokuanzeneiseibu-Anzenka/0000128236.pdf>）が出されまして、これをみると、経緯や災害の概要が載っていきまして、「災害発生メカニズム」（下図参照）についても弊所が提出した災害調査報告書から抜粋されたものです。詳細は割愛しますが、このメカニズムについてもこうした重大災害は単独の原因で発生するものではなく、複数の要因が重なって重大事故に至るものです。この事故も、報告書にあるように、①から⑧まで様々な原因が指摘されています。これらの裏にはもっと多くの小さな原因が折り重なって災害につながっているという状況です。先ほど示した鉄筋コンクリート製のセグメントがバラバラになってこのような事故になったというシミュレーションができています。



シールドトンネルの施工に係る安全対策検討会 災害発生メカニズム

災害発生メカニズム

- ① 26リングにおいて掘進線が設計画線から切羽に向かって左に約200mmずれていることが確認された（立坑及び横坑の測量結果より）。
- ② 85リングの掘進中又は組立て時に、裏込め注入材がシールドマシンのテール部を通過し坑内に漏れ出し、テールブラシ内で裏込め注入材が固結し始めた。そのため、85リング以降、テールクリアランスの値がほぼ一定値となった（掘進管理システムデータより）。
- ③ 94リング付近から、セグメントの線形を設計画線に戻すため、シールドマシンを切羽に向かってさらに右方向に向けるが、セグメントは逆に左方向に向かい、シールドマシンとセグメントの方向に齟齬が発生した。そのため、裏込め注入材が固結したテールブラシとセグメントの競りが発生した。
- ④ 112リングのB 2セグメントを組立てようと111リングのKセグメントを支持していたジャッキを引き抜いたところ、シールドマシン前方からの切羽圧によってシールドマシンがテールを下げ、セグメント上部との競りが発生した（掘進管理システムのデータより）。
- ⑤ 111リングのKセグメントが切羽側に抜け出そうとし、リング継手が損傷し、111リングのB 1、B 2セグメントのリング継手（110リング側）の一部がせん断した。直後に**111リングのK、B 1、B 2が坑内にわずかに垂れ下がった**（リング継手の分析からの推定）。
- ⑥ 坑内への出水が始まり、切羽圧が低下し始めた（掘進管理システムのデータから）。
- ⑦ 出水が継続したことにより、地盤の緩みを引き起こし、110リング及び111リングの上部に作用する荷重が増大した（推定）。
- ⑧ 110リング、111リングの変形が進行し、両リングが崩壊し、大規模出水に至った（セグメントの破損状況の調査、個別要素法によりセグメント崩壊メカニズムをシミュレーションした結果から。図参照）。

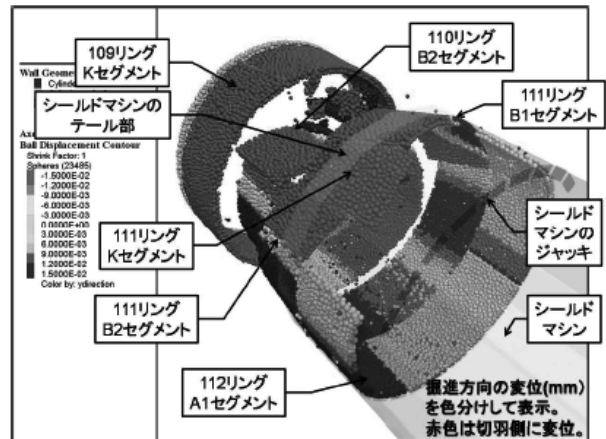

※独立行政法人労働者健康安全機構 労働安全衛生総合研究所の分析結果による

（出典：<https://www.mhlw.go.jp/file/04-Houdouhappyou-11302000-Roudoukijunkyokuanzeneseibu-Anzenka/0000128236.pdf>）

三柴 今の点ですが、大ざっぱな説明でけっこうなので、素人にもわかるように、どんな原因でどんな現象が起きたのか、説明していただけませんか。

吉川 [吉川委員による以下の図解入りの説明は、本会議のZoom記録（2：07：25～）参照。]

まず、このシールドマシンの施工手順ですが、シールドマシンの全面にはカッタービットがあり、これで地盤を掘削しながら掘り進んでいきます。掘った土砂はスクリーコンベアで運ばれ、坑外に搬出されます。シールドマシンの中には、このようなシールドジャッキというものがあり、このジャッキをセグメントに押し当てて、ジャッキを伸ばすことによってシールドマシンが進んでいきます。伸ばしたままだとシールドジャッキの延長が足りなくなるので、伸ばした後はジャッキを引っ込めて、これによってできた隙間にセグメントを組んでいきます。そうして複数のセグメントを組むことによって、リングを作ります。そして、またジャッキをセグメントに押し当てて前に進んでいきます。これが通常の方法ですが、事故はどのようにして発生したかという点、動画でお見せします。

先ほども説明したように、B工場からシールドマシンで掘進していたのですが、ちょうど112番目のリングを組んでいる最中の事故でした。ここに新たなセグメントを入れるために、このジャッキを引



き抜きました。そうするとシールドマシンが少し頭を上に向けて、なおかつ後尾が下がります。ここには水が入ってこないようにテールブラシというブラシがあって、このブラシが111番目のリングのセグメントをグッと押します。ここには水圧もかかっていますので、111番目のキーになるセグメント(Kセグメント)が少し抜け出してしまったのです。抜け出したセグメントの間から、水や土砂が少しずつ流入してきまして、耐え切れなくなって111番目と110番目のリングが大崩壊したという災害になったのです。

次に、シミュレーション結果です。今度はこちらがシールドマシン側で、これがリング側なのですが、ここはちょうど112番目のリングです。ここが111番目です。そしてここが110番目、109番目になります。ここに小さな四角い形に見えるのが、先ほどのシールドジャッキの足下になります。この足下を引き抜くとどうなるかという、111番目のKセグメントのリングが少しシールドマシン側に抜け出てきます。ここにボルトがあるのですが、ボルトが切れ、海水が流入し、そうこうしているうちに110番目も壊れ、111番目も壊れます。そういう形で崩壊が進み、中にいた作業員が海底地盤の土砂や海水に水没してしまったという事故です。

そういう事故を受けて厚労省で検討会が開催され、先ほどの報告書が出されました。報告書の概要の中には、8項目からなる災害発生原因のメカニズムが示され、その裏返しで再発防止対策になりますので、それがこういう形で示されました。ご覧いただくと分かりますように、一つの重大災害ではありますが、複数の再発防止対策が必要になります。それを条文化すると、いくつもの条文になってしまうという状況です。この検討会報告書の目新しい点としては、施工者、元請、下請だけではなく、発注者や設計者による取組みにも言及したという点かと思われまます。検討会報告書を受けて、同じ年(2016年)の12月28日に「シールドトンネル工事に係る安全対策ガイドライン案に係る意見募集について」ということで、パブリックコメントが公募されています。このパブコメも吉川資料にてURLをつけているので、後ほどご覧いただければと思います。これを受けて再度修正し、翌2017年3月21日に、厚生労働省労働基準局安全衛生部長から基安発0321第4号「シールドトンネル工事に係る安全対策ガイドライン」の策定についてが発出されました。内容をご覧いただくと、冒頭に前置きがあり、次いで本体の「シールドトンネル工事に係る安全対策ガイドライン」には、「第1 目的」「第2 適用範囲」・・・と続きます。目新しい点としては「第3 発注者による取組」に触れているところです。弊所の災害報告書にも書かせていただきましたが、それを受けて発注者による取組みもガイドラインにかいてくれたということです。次いで「第4 設計者・施工者による取組」ということで、通常は元請だけなのですが、設計者についても触れられています。その内容としては、「1. 適確なリスクアセスメントを踏まえた設計及び施工計画」「2. シールドマシン」「3. セグメントの設計等」「4. テールシール用グリース」「5. 線形管理」「6. 掘進管理」「7. セグメントの組立」「8. 掘進状況に応じた施工計画の見直し」「9. 避難、救護の訓練」、といったもので、一つの災害ではあるのですが、それを防ごうとする以上、やはりこれだけの条文が必要となってくるということです。

私からの報告は以上です。

三柴 ありがとうございます。まず私から申し上げますと、災害調査報告は行政でつくるものだけではなく、民間が独自に作るものもあります。私が割と馴染みだったのは鉄鋼業界の災害報告で、これは業界内で災害が生じると報告書を作成して共有しています。合併前の新日鉄も住金もJFEも、業界内で

再発防止のために共有していることはそれでいいんですが、読んでいてつくづく思ったのは、総論的な書き方で要点がわからず、現場で応用しようと思ってもどう使っていいかわからないといった側面も見受けられます。あれもこれも手を打てればいいのですが、規制科学というのは時間勝負でもあるから、要点を押さえてなんとか防止しようと思うのであれば、あまり総論的であってはいけないのではないかという思いもあります。報告書の要点、要するに一番言いたいことは何か、という点が浮き上がるような内容にする努力・意識は、吉川先生がこの事故調査の経緯に関わっていただいていたのでしょうか。

吉川 分かりにくいかもしれないのですが、厚労省もいろいろ工夫はしています。平成26年6月提出の弊所の報告書 ([https://www.jniosh.johas.go.jp/publication/pdf/saigai\\_houkoku\\_2016\\_02.pdf#zoom=100](https://www.jniosh.johas.go.jp/publication/pdf/saigai_houkoku_2016_02.pdf#zoom=100)) は、分量的には451頁もあります。専門家でもすべて読み切るのは容易ではありません。しかしこれでも、検討会では内容をかなり絞り込んでいます。厚労省は、「シールドトンネルの施工に係る安全対策検討会報告書（概要）」 (<https://www.mhlw.go.jp/file/04-Houdouhappyou-11302000-Roudoukijunkyokuanzeneiseibu-Anzenka/0000128236.pdf>) のように、パワーポイント資料で7頁程度に収めています。経緯や災害の概要なども一応図式で示しているし、分かり易い工夫はしているつもりです。文系の方からこれでも“分かりにくい”と言われてしまったらそれまでなのですが、一応専門家が見れば、これくらいの分量であればすんなりと頭に入ってきます。シールドトンネルの施工や建設に携わる人であれば、読むのにまったく抵抗はない状態にしています。ガイドライン自体は文章ばかりで分かりにくいのですが、分かり易く読める工夫はしてくれているという状況です。

三柴 私が言いたかったのは、専門家にとっては読みやすくても、非専門家も制度作りに関わるがゆえに、彼らにもわかるようさらに要点が絞れていなければなりません。そうでないと非専門家には伝わりません。最近の産業保健関係のテーマでいえば、たとえば癌の両立支援について。私がさる行政官に、要点は何でしょうか、政策にすることによって何を打ち出したいのかとお尋ねしたところ、結局は多様な働き方、すなわち仕事から早めに帰って通院ができる等するために、働き方を柔軟にすることがポイントであるといった内容の答えが返ってきました。もちろん技術的にはいろいろ原因があつて、様々な対策が考えられると思いますが、あえてそれくらい単純化しないと、多職種の人が集まって何かしようとすると、特に制度を作ろうという場合には、そういう視点は非常に重要だと思います。ただ、研究所も行政も非常に優れた報告書やガイドラインを作っているし、大変な努力をなさっていることは十分伝わってきます。

もう一つですが、なぜガイドラインか、ということです。これほどの大問題が生じ、そしてここまで大掛かりな検討をしてきたにもかかわらず、なぜ規則が制定されないのでしょうか。

吉川 その点につきましても、今後余力があれば検討課題にしたいと考えています。

三柴 大変すばらしいご報告でした。私から最後に指摘したいのは、こういうものこそがまさしく規制科学で、こういうイメージが伝わるような本を作りたいと思っています。分野によって様々なモデルがあると思うのですが、建設安全に関しては、まさにこういうモデルが求められます。吉川先生のご報告さ

れた図とイメージが伝わるようなものが理想です。

他に先生方から何かご意見・ご質問はよろしいでしょうか。

平岡 現在は私は災害調査分析センターという、災害調査を請負う部署におります。先ほどのお話の補足のようなお話になりますが、企業などが情報共有のために出している災害調査報告書はおいといて、弊所が実施している災害調査報告書は、あくまでも科学的な原因究明と再発防止という点に重点を置いています。ですから、警察や労基署のような誰が悪いのかという責任追及はやっていません。あくまで科学的な原因究明と科学的な再発防止対策に終始しています。私が最初に担当した災害調査では、誰に責任があるのかについて切り込んで書こうかとしたのですが、科学者である以上、責任の所在は警察、労基署、そして最終的には裁判所の仕事であって、我々の感知すべきことではない、科学者として科学的知見をまとめるべきだと指摘されました。そうすると、種々の原因を並列に列挙していくことになりますので、いきおい分かりづらくなってしまいます。ただ、水島港の事故は相当大きな災害だったことと、吉川先生が非常に精力的に調査なさったおかげでかなり詳細な分析がなされていますので、どこに原因があるのか分かり易くなっています。このクラスの規模ではない毎年発生しているような小規模な災害については、調査報告書を読んでも専門家でない限り分かりにくいのではないかと思います。

吉川 ありがとうございます。今後、幅広く多様な災害の調査をするとなると弊所の専門性等の問題からするとなかなか難しいところがあります。平岡先生は土砂崩壊がご専門で、私もどちらかといえば土砂崩壊やトンネル事故が専門なので、土砂崩壊災害に絞って規制の流れなど、工場法あたりからどのように法律や規則やガイドライン等ができたのか、その経緯について土砂崩壊に限定して今年度の調査にあたらせていただければと考えています。そのような形で大丈夫でしょうか。

三柴 ぜひそうしていただきたいと思います。今の平岡先生のお話に追コメントすると、安全衛生研究の本質にかかわることですが、私なりの理解では、それは再発防止学やリスク管理学なわけです。そうすると、確かに科学的な基礎にわたる研究も大切ですが、最終的な目的は再発防止、あるいは発生しそうな災害のリスクの防止です。その意味ではやはり、専門分野にこもりすぎではマズいかな、という気もします。いかなる専門分野であってもそうです。そういうことを追コメントという形で、軽い趣旨でお伝えできればと思います。いずれにせよ、日頃関わっているということと、現にご専門であるということもあって、吉川先生のご報告は非常に素晴らしいものだと思います。

吉川 ありがとうございます。

三柴 では、森先生のご報告の前にいったん休憩をいれたいと思います。

三柴 では、再開させていただきます。資料の画面共有は私の方で操作します。この資料（※「労働安全衛生法令に基づく化学物質による健康障害防止対策の現状と課題」、以下「森資料」）でよろしいでしょうか。

森 はい、ありがとうございます。昨年度、私は健康診断というテーマで全体的・横断的に検討するという課題をいただきまして、一応全部書ききったつもりですが、実際には専門外の人に対する分かり易さ、あるいは図表を入れての解説といった点などが不十分という認識です。これらについては今年度の課題として対応していきたいと思っています。また、新たなテーマをとということで、今回すでに石崎・唐澤両先生が法的な内容も含めて説明して下さったテーマとかぶりますが、化学物質と健康障害防止対策というテーマを全体的にまとめるという課題をいただいたところです。この場合の化学物質とは、繊維状物質なども含めるとかなり複雑になって情報も増えて、取扱いも変わってしまうので、それ以外の重金属や有機溶剤その他の化学物質に限定して検討していこうと思っています。本日はその目次と総論的なポイントを示すことで、概略どのような項目を盛り込もうとしているかを説明させていただきます。

森資料1頁の目次をご覧ください。「はじめに」においてなぜこのようなテーマを検討するのかを書いた後に、「Ⅰ 化学物質による健康障害の発生と管理の原則」という項目を最初に立てようと思っています。内容は後ほど説明いたします。

2番目に「Ⅱ 化学物質による健康障害防止対策の基盤」という項目の中で、今回最後の方で法令、特に特別規則のお話が出てきますが、化学物質による健康障害の防止を前提とした一般規定があります。これを遵守するなかで化学物質を分類してゆくのですが、より詳細に分類しているものとそうでないものがあるというお話を、「2. 規制対象物質の分類」に書いています。ここでは、法令でどの程度詳細に規制しているのか、どういう趣旨で分類しているのかなどといった問題のほか、一般規則の次に絞った対策がSDS交付対象物質で、この部分は努力義務の部分と義務の部分がありますが、リスクアセスメントの対象になるので、何らかの形で対応するように、義務ないし努力義務規定が置かれている点についても書こうと思います。さらにその中で、法令や特別規則によって規制項目が決められ規制対象になっている物質について考察した上で、最近の国の対策では主に発がん性に着目した分類やがん原性物質に対する指針が出されていますが、それらの点は少々クローズアップした形で分類を作成しています。さらに、化審法（化学物質の審査及び製造等の規制に関する法律・昭和48年法律第117号）に関わる問題ですが、新しい科学物質を産業界で使おうとする際にどのようなプロセスがどの範囲で適用されるか。化学物質というものは、単体で用いられることはまずありません。混合物として使う際に裾切値が法律上またはSDSで定められているので、それがどのような全体像になっているかを検討します。最後に化学物質の報告制度、つまり国が行うリスクアセスメントです。現在、対象物質の見直しが順次なされていますが、そのために段階ごとに委員会が設置され、所定の手続きを踏みながら毎年新しい特化物が加わり、その数が増加している状況なので、その手続きがどのようになっているかという問題とあわせ、規制対象となっている化学物質となっていない化学物質との全体像を示そうと思います。物質という角度からの検討です。Ⅱ・「3. 化学物質管理のための体制」においては、先ほど議論があったところですが、わが国ではこういう問題については事業者が責任を負うのが基本ですが、他には衛生管理者や産業医に関する規定、取扱主任者や職長教育の規定の中に関連規定がある程度です。化学物質のリスクアセ



メントのガイドラインの中には、“化学物質管理者”が出てきます。こういう人たちについてどのような規定があるのかについて書いたうえで、わが国で有害物管理をする人たちの教育がどうなっているか海外の状況にも触れながら、人材面で未規制物質も含めて包括的な管理ができる体制にあるのか、そういった議論もここに書こうかと思えます。

「Ⅲ 化学物質による健康障害防止の戦略」では、様々なレベルの化学物質が存在することに対して、それらによる健康障害をどのように防止をしてゆくかといった内容を検討するわけですが、その中でまず、化学物質による健康障害の防止戦略の前提のお話を書いたうえで、「2. 化学物質のリスクアセスメント」、「3. 化学物質のリスクコントロール」・・・といった順序で書きたいと思えます。リスクアセスメントの項目では、リスクアセスメントの義務化の話に触れます。有害性情報をどのように把握し、曝露をどう評価し、許容濃度等・・・“等”と書いてありますが、ここには管理濃度や生物学的曝露指標といったものが出てきますので、それぞれに合わせてどうするのか、またリスクの見積り・・・これは国が定めた指針以外にも、職場の安全サイトといったところにリスクアセスメントのツール、最近ではクリエイティブシンプルのようなもう少し実践的なものも掲載されていますので、これらも紹介しようと思えます。化学物質のリスクコントロールに関しては、発散の抑制、個人用保護具、健康管理に関わること、特別な健康状態の人への配慮・・・ここでは“健康状態”と言えるかどうかはわかりませんが、女性則における有害物の取扱いの問題として、発散する場所における作業禁止の問題を書こうと思っています。リスクコントロールの前提になるのですが、自身がどの程度どのような曝露をしているのかについて労働者に周知し、彼らの知る権利を保護することが非常に重要で、わが国ではこの点についてつい最近まで相当おろそかな状態になっていましたが、この点も指摘する必要があります。個人用保護具の中では、SDSのなかで皮膚からの吸収ということが当初から言われていましたが、わが国で皮膚吸収のおそれのある化学物質に対して保護衣や保護手袋の着用を義務化したのは、最近の膀胱がんの事例が契機で規則改正につながった故のことで、自主管理とは言いながら、自主管理のはざまにおいてもなお可能な規制が多くあるのに、後手後手になっているといえます。つまり、障害が発生したがゆえに事後的に手を打つ形にはなっていますが、実は以前から判明していたリスクでしたが、そういった点にも触れたいと思えます。リスクマネジメントを進めようとする、その基盤となる体制やシステムが必要となりますが、そこで「4. 労働安全衛生マネジメントシステム」を検討する項目を入れたいと思えます。労働安全衛生マネジメントシステムとしては最近「ISO 45001」が出され、また国のマネジメントシステムの指針も改正されました。その点にも触れたうえで、日本の場合特に安全が中心になっていて、今回出された「ISO 45001」でも、たとえば必ず30分以上産業医のインタビューを実施するよう監査機関の間で申し合わせがなされているのですが、インタビューは30分ももちません。なぜかと言えば、監査員側が産業医に何を聴いたらいいのかわからない程度の力量しかないという問題が生じているからです。化学物質の問題も同様で、マネジメントシステムをめぐって作る側と運用する側と監査する側の関係をどうするかといった大きな課題があり、そこにどこまで踏み込むかは別として、そういった点も念頭に置きながら検討したいと思えます。

ここまでは自主管理の話ですが、今回はプロジェクトの各班が法律を中心に検討しているので、「Ⅳ. 特別規則による管理」については、森資料2頁のような構成になっているという記述をしつつ、特に特化則の中に含まれる物質が色々な形で分類されているので、各分類ごとにどのようにしているのかを検討するつもりです。また、有機溶剤中毒予防規則に入れるか特化則に入れるかまだ決めていないのです



が、特別有機溶剤、すなわち発がん性を有する有機溶剤を特化則・有機則の双方で管理しようとする、どのように管理すればいいのかが専門家でも説明が難しいルールになっていて、おそらくこれがわが国における法令による管理は無理だという、臨界点を越えた問題だと思っています。その複雑な問題を書こうと考えています。

最後に「V. 労働災害の認定基準および訴訟」です。労災の認定基準に関しては確実に書こうと思いますが、問題はそれ以外の部分です。化学物質による健康障害の訴訟は、大きく分けると二つあります。一つは、化学物質過敏症の事案であり、二つ目は癌のケースです。どちらも因果関係の立証が非常に困難な事案で、法律的な問題とはズレるものが多いので、その辺りの特徴を少々記述しようと思っています。取り上げる訴訟例の中には、日本産業衛生学会が巻き込まれた許容濃度に関する事例も含めようかと考えています。これは、プロモプロパンに関して日本産業衛生学会による許容濃度が厳格すぎ、そのために販売量が減少しこれを取り扱う企業が損害を被ったとするものです。日本産業衛生学会の許容濃度には、多くの場合管理濃度の基準に準用されることがあるくらいに影響力があるにもかかわらず、科学的な根拠もないままかかる濃度基準を示したとして提訴されたものです。結論的には学会側が勝訴しているのですが、同種の訴訟は欧米ではしばしば提起されるようなので、日本でも今後起きる可能性があるということです。

全体像は以上の通りです。

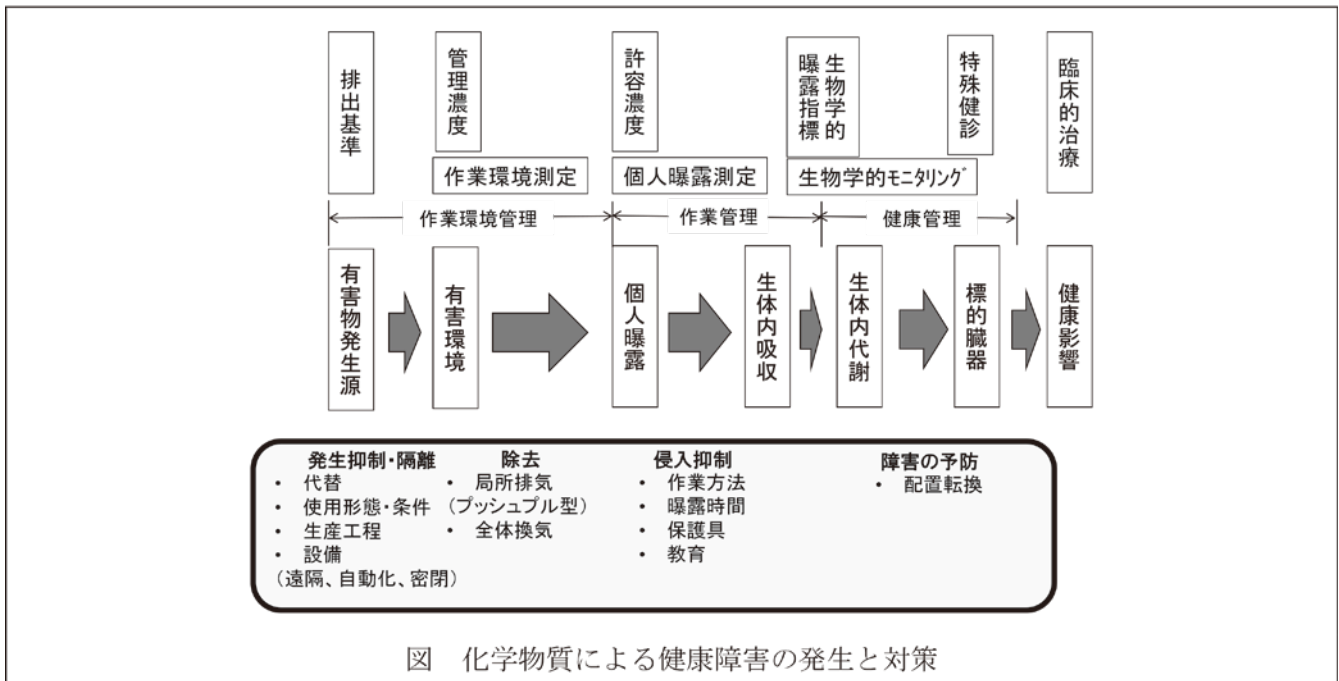

最初に戻って「はじめに」の部分は、いろいろな化学物質がつかわれていて、日本ではそのうち7万物質程度が産業界で用いられているという厚労省のデータを引用します。ただ化学物質の危険有害性は多種多様であり、物理化学的危険性、人への有害性、環境生物への有害性、地球環境への有害性・・・今回はこの中の人の健康に対する有害性に特化して検討する旨書きます。そして、化学物質の健康障害の発症と管理の原則ということで、最初に化学物質がどんなふう健康障害を引き起こすかについて、作業環境中に拡散するところから実際に健康障害を起こすまでの流れを書いたうえで、作業環境管理、作業管理、健康管理の範囲でそれぞれ図示し、測定する際には測定方法と基準値がある旨書きます（※上図参照）。そして対策としては発散抑制から障害の予防までの段階があるということです。化学物質による健

健康障害が起きるまでの流れと、それに対する管理対策、モニタリングを並行して図を載せた次第です。

いま言った内容を説明していった、対策を講じるにあたっては、化学物質を代替したり生産工程を変更したりするところから始まり、拡散の防止・低減、保護具の着用、配置転換といったような、コントロールの順番を並べています。IS45001でも必ずこういう書き方をしないとイケない順番と一致しています。最後に「三管理と管理状況の評価方法」、これは先ほどの図とかなり重複しますが表にまとめました。そのあと、化学物質の分類があり、Ⅲに飛びますが、ではそういった化学物質をどう管理するのかについてですが、化学物質の曝露には、急性曝露によるものと慢性曝露によるものがあり、急性曝露によるものは化学物質の漏洩や貯蔵された容器への転落など、予期せぬことによって発生するものなので、基本的に安全対策と同じです。そのため、ここでは主として慢性曝露の対策を記載します。そこに書いたように、化学物質の慢性曝露による健康障害を防止するためには、密閉化などの対策が行なわれます。ただ、すべての化学物質を密閉化するわけにはいかないもので、リスクアセスメントを実施して、リスクの程度に応じて対策に優先順位をつけることになる、リスクアセスメントを実施した結果、リスクが十分低い状態まで低減する、または残存リスクに対して対策を講じる、といった内容を書きました。リスク低減が許容レベルにまで図られたとしても、リスクアセスメントでは見逃した曝露があったり、新たな健康障害が発生する可能性があったりするため、健康診断が必要になります。この章はそのあと、リスクアセスメントの話、有害性の情報、曝露評価、許容濃度等、といったように順番に検討していきます。先ほど別なところで解説がありましたが、まず化学物質の健康障害リスクの許容レベルにまでもっていくとすれば、その許容レベルをどのように定義するかという問題があり、基本は許容濃度です。許容濃度というのは、「労働者が1日8時間、週40時間程度、肉体的に激しくない労働強度で有害物質に曝露された場合に、当該有害物質の平均濃度がこの数値以下であれば、ほとんどすべての労働者に健康上の悪い影響がみられないと判断される濃度」と定義されています。この「ほとんどすべての労働者」というキーワードを抜き出して、なぜ「すべての労働者」ではないのかということを書いたうえで、例外的な労働者をどのように管理してゆくべきかといった話もそこに記載しています。

最後のパラグラフですが、「以上のような健康障害防止の対策の基本は、本来、有害性のあるすべての化学物質に対して実施すべき」ですが、一般原則が安衛法第22条に規定されています。しかしそれだけでは上手くいかないもので、有害性の高い物質や国内事業場での曝露状況を勘案するなどして、特別規則でリスクマネジメントに関して詳細に規定しています。がん原性指針もそれに準じた詳細な記載となっています。以上をⅢ・1で書いたうえで、化学物質のリスクアセスメントの内容、有害性情報、曝露情報、許容濃度の話などが続いていくような、そういう書きぶりになっています。

私が今年度に取り組もうとしている課題は、以上のような内容です。半分程度まで書き上がってしまっていて、情報もかなり集まっています。また、今回はせっかくの機会なので、特に化学物質について学びたいという本学の修練医1名、桑原と申しますが、医師3年目で臨床研修を終えたあとにJFEスチールの製鉄所で勤務経験のある修練医です。彼に3分の1程度執筆を担当させ、私がチェックするという形で共同して取り組もうと考えています。

以上です。

三柴 ありがとうございます。大変意義の大きな文章をいただけそうで、感謝の至りです。先生方からご質問・ご意見などがありましたらお願いいたします。その前に、途中で福島原発をたとえに出された

“特別な健康状態”というお話がありました・・・

森 福島原発の話は、今回の報告ではなく、健診のテーマの際に出た話だったと思います。健診に関して国が特別の健康診断を命じることができるという制度でした。緊急被ばく作業を行った人たちの健診を命じたということです。

三柴 なるほど、了解です。森資料1頁、目次のⅢ・3・(4)「特別な健康状態」の話を聴き逃したと思うので・・・

森 そこは母性健康管理について執筆する予定です。女性のみについて有害物の規制を施す制度があります。これも実はひどい話で、昭和22年に決めた基準がつい数年前まで存在していたというものです。許容濃度から外れるような人をどう守っていくかという話を少々書いています。

三柴 労働法の分野では、「保護か平等か」というキーワードで、労働時間管理などに関して、女性は工場時代からもともと特別に保護を要する人たちであったけれども、しかし平等な取り扱いを求めるのであれば保護も外さなければならないのではないかという議論が底流にあって、規制内容が変わってきたという経緯があります。産業衛生学では、母性保護については、今のところそういう水準に来ているのでしょうか。

森 基本は、女性保護ではなく「母性保護」です。平成9年の男女雇用機会均等法改正の際に、それまで妊娠した場合においては危険有害物の作業は全面禁止でよかったのですが、女性であることを理由に差異を設けてもいい、あるいは差異を設けなければならないのは、筋力の差ゆえの重量物取扱い、そして妊娠出産機能への影響があるようなものは社会的に問題があるので、そこは適切に保護をしましょうという話になっていました。後者を母性保護と位置付けます。その中に女性基準規則があり、条文数は失念しましたが化学物質に関する規定が設けられているのですが、それが昭和22年制定の基準でした。GHSができたことによって、生殖毒性や生殖細胞変異原性という毒性が明確に規定されたので、そのマーク（※下図参照）がついている作業環境測定が必要な化学物質については、一定レベル以上であったら女性を就労させてはいけないという限定的な基準を作りました。この基準を作ったことによって、適用対象となる人たちは就労禁止となったわけですが、実は重量物も化学物質の取扱いも、本当は男性であっても就労させてはいけないレベルなんです。しかしひとつだけ利点がありました。化学物質で規制されていないような物質で、不安を感じる人はいるわけです。そういう人たちの中から、そろそろ子作りを考えているがゆえに相談に来る人がいるわけです。その時に規制を準用して保護に結び付けることができます。そんな内容のことも執筆しておくといいのかなと思っています。



石崎 今のお話との関係で一点よろしいでしょうか。女性則が平成26年に改正され、妊娠出産授乳機能に影響与える化学物質が第3管理区分になった場合に、女性労働者の就業を禁止する規定が設けられたと・・・

森 いえ、“設けられた”のではなく、以前からあった規定が厳しくなりました。たとえば鉛などのように、従前はもっと規制が甘かったのです。

石崎 では、もともと存在した規制だったということですね。

森 対象物質が何で、またそれぞれの対象物質ごとにどこに基準値を設定するか、この2つのポイントを決めなければならないわけですが、それが元々ありました。しかし従前の規制の根拠がおよそ科学的なものではなかったのです。それを科学的に規制しなおしたということです。

石崎 対象物質自体は増えているのでしょうか。

森 増えています。先ほども言いましたように、作業環境測定の対象となっている物質で、第3管理区分以上のものがそうです。

石崎 ここ読んだときに、妊娠の有無とか年齢に関わらず全ての女性の就業を禁止している点が、分かるような気もしつつ、若干過剰規制という気もしつつという感じを受けていました。

森 そこが母性健康管理なわけで、“妊娠可能な”女性も対象に含まれていいと思います。しかし、妊娠可能な女性というのを区分するのは大変だろうと思います。この基準は2回にわたって見直されていて、その前は炭鉱労働の監視業務はOKとしました。私はその前の委員会の委員だったのですが、GHSが出たらGHSに則って規制をかけられるので、今回は見送りましょうということになり、その後GHSに従って規制が施されたという経緯があります。

石崎 そうすると、医学的には適切な規制ということですね。

森 適切な規制かもしれませんが、範囲が狭すぎる規制であるといえます。

石崎 狭すぎる、ということは、本来なら男性も対象とするべきだという意味で？

森 いえ、作業環境測定の対象物質のみが規制対象となっているに過ぎないという意味で、範囲が狭すぎるということです。事業者が測定もしていないのに、規制対象に含めるか外すか決定できませんし、場合によっては先ほど三柴先生が指摘されたところの、過剰な配慮につながりかねず、不平等になってしまう可能性も考慮してのことでしょう。既存の作業環境測定のデータがあればそれを使えますので、あ



えてそのような線引きをしたのではないかと思います。

石崎 ありがとうございます。

三柴 先生方から他にご質問やコメントはございませんでしょうか。

石崎 続けて恐縮なのですが、労働者への周知という問題に関して、作業環境測定の評価結果や改善措置について、特化則や有機則では周知義務が課されているのですが、石綿の粉じんについて同様の規定が見当たらなかった（もしかすると私の見落としかもしれませんが）、この点についてご説明いただければと思います。

森 それについては、私も分かりません。

石崎 私もこの点は気になっていました。もう一度確認して、MLにも投稿させていただこうと思っています。

三柴 もしかすると、そもそも製造禁止という原則的に厳しい規制をかけているがゆえに、周知の問題は生じる余地がないということかもしれません。調べてみる価値はありそうですね。

石崎 ありがとうございます。

三柴 では森先生、恐縮ですが、修練医の先生とご一緒に、ぜひこれを書き上げていただきたいと思います。また、お手数ですが、初年度の法定健診制度の方は門外漢にもわかるように調整していただき、今年度の課題としては、先ほどご報告いただいた化学物質管理の総論・各論ですね。できれば、健診について書いていただいた問題提起と解決の方向性、それについても意識していただければと思います。

それでは、森先生のご報告はここまでで、最後に横断的検討課題の担当者を決めたいと思います。現時点で抽出された課題としては、開催要項6に挙げられたものです。「危険有害物質へのばく露管理」および「健診制度の在り方」については、すでに森先生に執筆していただいたか、あるいは今後執筆していただく予定です。「危険有害物情報の共有」については、森先生にお任せしてよろしかったでしょうか。メーカー等の譲渡提供者が現場で当該物質を労働者に取り扱わせる場合、事業者に対して云々というテーマです。

森 情報の提供ということであれば、それについては私が書きます。

三柴 ありがとうございます。先生方にご相談したいのが、黄色の帯を付した部分、すなわち「性能要件規定の是非と射程（三柴）」です。調べてみたところ、旧労基法の旧安衛規則時代から性能要件規定、つまり達成すべき目的のみを規定した上で、これを達成するための手段については事業者の裁量に委ねるという規定ですが、これがすでにその時代から設けられていました。おそらくそれ以前からあったかも



しれません。通常の危害防止基準のように箸の上げ下げまで細かく規制するのではなく、目的だけを明示してやり方は任せるという方法です。そのような類の規定について、そもそもそういう定め方は適切なのか、適切だとすればどの範囲まで可能か、などといった点を検討します。これについては私が担当します。

法学系の先生方にはお一人につき2テーマを担当していただきたいという前提で各自選んでいただきたいと思います。

「発注者の責任」は、本日の吉川先生のご報告にも出ましたが、法学系の先生方にあらためてイメージをお伝えしますと、職場で労災が起きる原因がそもそも発注者にあるケースがあります。特に建設業で、たとえば変わった形状の建物を工期3カ月で完成させる旨の発注をしたとすれば、労働災害が起きて当然です。また、その土地特有のリスクについて適切に伝えもせずに工事を進めさせた場合もまた然りです。そういう場合の責任をどう考えるかというテーマです。

「中小企業の安全衛生管理」は、法解釈論というよりは政策論になるので、法学系以外の先生にお任せした方がいいかもしれませんが、法学系の先生の中に関心のある方がいらしたらご担当ください。場合によっては、行政学ご専門の大藪先生が適任かと思いますが、現場に詳しい方に書いていただくのもいいかもしれません。

現在どのような政策課題でも問題となるどころの、「AIの普及、いわゆるクラウドワーカーや委託就労型労働者の増加見込みなどを踏まえた安衛法規制のあり方」ですが、これは安全衛生でも問題になります。第4次産業革命という言葉が現在出てきておりまして、要するにAI等の機械が人間の機能を極限まで代替する状況の中で、産業がどのように変化し、人間の労働がどう変化し、それらの変化を踏まえて規制をどのようにするかという課題です。端的に言えば、第4次産業革命の主唱者の物言いをみると、人間の手で行う価値のある労働は当然限定されてきます。その結果人間に残された労働は、ひとつには創造、つまり無から有を産む作業です。そして、人間の感情への寄り添いです。これもかなり代替が可能になってはいますけれども、やはり生身の人間でないと納得がいかない部分は残るでしょう。それらとあわせて価値判断です。いろいろな考え方があり得て、どれが正解とも一概には言えないものの中から選択をする作業は、やはり人間でないとできません。そこらへんが人間の労働として集約されていくだろうと言われます。他方、機械との競争に敗れた人間も多く出てきますが、そういう人たちは低賃金・低条件で働かざるを得ない状況になってくる可能性があります。たとえば、現在街中でよく見かけるウーバーイーツ (Uber Eats) ですが、彼らの労働はキツイのではないかという問題提起がなされてきています。そういう人たちの安全衛生とはどうあるべきか、規制はどうすべきか、といったこともあわせて考えていく必要があります。AI時代の勝ち組の安全衛生と同時に、負け組の安全衛生も考えなくてはいけないということです。

「労働者派遣法制度と安全衛生法制度の関係」ですが、これは鎌田先生にお願いしようと思います。

「安衛法の私法的効力、立証責任」、これは井村先生にお願いします。そして、「危険を及ぼす可能性」は原先生にお願いします。

「産業ロボットへの接触に関する規制」は技術的な問題ゆえ、法学系の先生以外の方にお任せした方がいいかもしれません。技術系の先生の方が相応しいかと思います。もともと報告書を書く予定のない先生方であっても、ご関心があればぜひご担当ください。

ラインアップは以上です。他にもあり得るかもしれませんが、とりあえず初版はこのような感じでよろ

しいかと思えます。

その後各検討課題の担当者につき、MLを通じて三柴座長より以下の提案がなされた。

- ・性能要件規定の是非と射程（三柴）
- ・作業関連疾患の予防（阿部理香・田中）
- ・犯罪捜査と行政権の行使との境界（鎌田・田中）
- ・罪刑法定主義と安全衛生の確保の関係（藤森先生、玉泉先生、適任者をご紹介下さい。元検察官経験者等が適任かと存じます）
- ・「危険のおそれ」（原）
- ・発注者の責任（石崎）
- ・危険有害物質へのばく露管理、危険有害物情報の共有（森）
- ・法定健診制度の在り方（森）
- ・中小企業の安全衛生管理（高木元也先生・安衛研）
- ・AIの普及、いわゆるクラウドワーカーや委託就労型労働者の増加見込みなどを踏まえた安衛法規制のあり方（山本）
- ・労働者派遣法制度と安全衛生法制度の関係（阿部未央）  
派遣法第45条の取扱方法
- ・安衛法の私法的効力、立証責任（井村）
- ・産業ロボットへの接触に関する規制（藤森、藤森氏のご紹介者・安衛研）
- ・SGDsと労働安全衛生（法）（永田智久氏・産業医大）

三柴 では、予定の時刻が過ぎましたので、本日も長時間にわたり非常に闊達で有意義なご議論をいただき、ありがとうございました。

三柴 本日もご参集いただきましてありがとうございます。よろしくお願ひいたします。

今年度は分担報告書の締め切りを10月末に設定している関係で、締め切りまでに開催できる会合はおそらく2回ほどになるので、本日の会合も重要な機会という認識で進めさせていただきたいと思ひます。早速ですが、MLで配信した開催要項にそつて進めていきます。まず、新任の委員の先生方をご紹介します。本日お見えになっていませんが、高木元也先生が新規に加入されました。ご専門が建設安全ということで、次回は特に中小企業の安全衛生管理についてお話しいただく予定になっています。また、再来年の労働法学会で一緒にご報告をいただく予定の長谷川聡先生（専修大学法学部教授）も新規に加入されました。同じく学会報告メンバーでもある北岡大介先生（東洋大学法学部専任講師）にもご加入いただきました。また、淀川亮先生（弁護士）にも新規にご加入いただき、本日の会合にも後ほどご参加いただく予定になっています。

本日予定している重要な作業のひとつは、分担範囲の再編成です。とはいつても、再編すべき内容は絞られており、私の分担範囲の一部を新規加入予定の淀川先生にお任せしようということですが、淀川先生は、個人情報保護に詳しい岡村弁護士の事務所（英知法律事務所）に勤める若手の弁護士で、私が最近開催している私塾に参加し、安全衛生法について非常に熱心に学んでくれているので、これを機にメンバーに加わっていただいた次第です。それと、大藪先生は法学者というよりは行政学者で、もともと官庁のキャリアとして内閣府や厚労省にお勤めだったのですが、分担範囲の負担が少々重ひと思ひますので、可能であればその一部を内藤先生にお引き受けいただけないかと思ひています。安衛法の第106条から第108条について条文をご確認いただくと（※下記参照）、このあたりは法学者が普段関心をもって取扱うような、たとえば違反に対して民事上どのような効果が出るかといった類の条文というよりも、履行確保を図るための規定です。安衛法は要所要所、事業者らにああしろこうしろと、義務規定を設けていますが、後ろの方では、他の条文では規定しきれなかった安全衛生の履行確保を図るために、現場の当事者を周辺から支援するための規定が並んでいます。たとえば、第106条は法規定を遵守するだけでなく、安全衛生を確保しようとする事業者に対して、たとえば必要な資金を貸すとか、技術的な支援をするといったように、国が手助けをするための規定です。第107条は厚労大臣の役割として、安全衛生の確保を図るための専門家、特に国家資格者を中心とした人たちですが、その人たちの資質の向上を図るという規定です。そして第108条ですが、安全衛生は常に産業技術の最先端をカバーしていないと確保できないし、実際に様々なりスクが顕在化するので、それらに対応するために安全衛生のための研究開発を進めなければいけないということで、本日もお越しいただいている安全衛生総合研究所が設立され、専門的な研究に従事しているわけですが、その根拠となる条文がここにあります。安衛法は、単に義務や禁止事項を定め、監督官が強制してそれで終わりというものではなく、法令を遵守しようと思ひてもそれが難しい事業者もいるし、単に法令を守っているだけで安全衛生を確保できるというものでもないのひで、法令順守や安全衛生確保のための側面からの支援をするための条文がこの辺りに並んでいるわけです。

（国の援助）

第106条 ① 国は、第十九条の三、第二十八条の二第三項、第五十七条の三第四項、第五十八条、第六十三条、第六十六条の十第九項、第七十一条及び第七十一条の四に定めるもののほか、労働災害の防止に資するため、事業者が行う安全衛生施設の整備、特別安全衛生改善計画又は安全衛生改善計画の実施その他の活動について、金融上の措置、技術上の助言その他必要な援助を行うように努めるものとする。

② 国は、前項の援助を行うに当たっては、中小企業者に対し、特別の配慮をするものとする。

（厚生労働大臣の援助）

第107条 厚生労働大臣は、安全管理者、衛生管理者、安全衛生推進者、衛生推進者、産業医、コンサルタントその他労働災害の防止のための業務に従事する者の資質の向上を図り、及び労働者の労働災害防止の思想を高めるため、資料の提供その他必要な援助を行うように努めるものとする。

（研究開発の推進等）

第108条 政府は、労働災害の防止に資する科学技術の振興を図るため、研究開発の推進及びその成果の普及その他必要な措置を講ずるように努めるものとする。

こういう条文は、実に安衛法らしい条文です。というのも、法律家が普段取り扱う条文とは少々違って、硬柔使い分ける安全衛生法らしい規定なので、こうした条文を掘り下げて調べていただければ、安衛法の本質をよく知っていただけたらと思います。内藤先生に、この3つの条文をご担当いただきたいと思います。いかがでしょうか。

内藤 大丈夫です。内容面でもご配慮いただいたようで恐縮です。似たような行政取締規定として、均等法や育児介護休業法の履行確保のための規定について、これまで検討したことがありますので、ぜひ取り組んでみたいと思います。

三柴 ありがとうございます、よろしくお祈いします。本日はご参加ではありませんが、この点について大藪先生にはすでに内諾をいただいておりますので、内藤先生、あらためてよろしくお祈いいたします。

このほか、現在分担している部分について、その一部を他の先生にお任せしたいという方はいらっしゃるでしょうか。

原 一点よろしいでしょうか。私の担当箇所のうち、安衛法第20条と第21条の紐付き政省令は、安衛則だけでけっこうな分量になりまして、そのため Gondola 則、クレーン則、ボイラー則に関して、詳しい方がいらしたらお任せしてよろしいでしょうか。詳しい方がいらっしやらなかつたら、もちろんなんとかトライしてみますが、できれば、安衛則に集中して取り組みたいと考えておりまして……。

三柴 このプロジェクトの担当の関係では、井村先生が詳しい分野ですが、井村先生の担当範囲が広いので、同先生にお任せするのも難しいと思います。後ほど、安全衛生の技術的な問題に詳しい方にご相談しようと思っておりますので、その際に合わせてお話するということでもよろしいでしょうか。

原 ありがとうございます。お手数おかけしますが、その方向でよろしくお祈いいたします。

三柴 私が忘れていたらリマインドお祈いします。

原 分かりました。お祈いいたします。

三柴 では、次の課題に入ります。会議開催要項の3、「今年度の調査研究方針」の要点をお伝えしたい

と思います。

まず、逐条解説を担当されている先生は、そのまま続けてください。特に、初年度の報告書に対して私が色々とコメントを付していますので、それを踏まえて書き足して、内容の充実化を図っていただきたいのです。その際に、私の分担報告書の項目をコピーして使ってください。項目立て自体が試行錯誤なのですが、一応私の分担報告書が試行錯誤の最先端をいつているということで、それを参照して各項目に当たるコンテンツを埋めていつていただきたいということです。

次に、今年度は横断的な課題についても検討を進めていただきたいと思います。これについては会議開催要項の6にまとめて書きました。各項目の趣旨が分からない場合、私にたずねてください。ニュアンスでお伝えできることもありますので、なるべくメールよりも電話で明確化を図っていきたいと思います。横断的課題についても分担者が決まってきたので、ご担当の部分を各自調査して、報告書としてまとまるように書き進めてください。

今年度の調査で重要な事柄のひとつは、逐条解説の中で【適用の実際】という項目を設けていますが、ここは元監督官の先生方のご協力を仰ぎながら執筆してゆくということです。ご自身で調べながらコンテンツを執筆している先生方もいらっしゃるようですが、やはりせっかく研究班にわが国でもトップクラスの安衛法の先生が揃っていて、監督行政実務のご経験のある先生もおられますので、その中でもグループ内で選ばれたリーダーである藤森先生にご助力を仰ぎながら、なるべく個々の条文について、監督行政実務ではどのように扱われているのか、具体的にどういう場面でその条文がどのように使われるか、絵でイメージを示すような形で、【適用の実際】を描いていきたいと思っています。これについては、元監督官の先生が北岡先生以外に3人おられますが、このお三方のみで全条文をカバーできるのかということも含めて、まず藤森先生と相談させていただきたいと思います。初年度にすでに、安衛法本法の条文とそこに紐付いた関係政省令の中で特に重要なものを洗い出し、それぞれが現場実務の中でどの程度重視されているか濃淡をつける作業は完了しました。法律本法については現場実務において重要な条文とそうでない条文に色分けし、関係政省令については重要なものを拾い上げていただき、膨大な数の条文の中から本プロジェクトで検討対象とすべきものを選ぶ作業を行っていただきました。それらのうち、どこまでについて【適用の実際】を具体的にイメージ化してゆくか、ということも含めて相談させていただきたいと思っています。この点については、藤森先生にあらためてお願いいたします。

初年度の報告書に掲載したため、ご覧になっていると思われるが、日本の安衛法の執行にかかわる社会調査を業者に委託して実施しました。なかなか興味深いデータが出てたというお話もしたと思いますが、これと同じような調査をイギリスで実施することによって、法文化つまり法の施行に関わる社会のあり方の違いを描き出そうと考えています。以前お話したとおり、イギリスでも社会調査をネットで実施する業者があるということなので、そのうち適切な業者を選んで実施しようと思います。

初年度は途中から、法学者を中心とする分担報告の執筆者に途中経過報告を行っていただくことが中心になっていましたが、2年目はそれと並行して、それぞれの研究班の先生方は各専門分野の知識と経験を日頃から磨いておられるので、それを披露していただくと思っています。先生方お一人お一人が主役であるという意識で2年目に臨んでください。それと関わることですが、いずれにせよ研究班全体のチームワークが良質な成果を生むために非常に重要なので、欠席された回については、必ずZoomの記録や議事録をご確認いただくようお願いいたします。以上が開催要項3についてです。

次いで、開催要項4の「分担報告書の執筆要領」に移ります。先ほども申しましたように、今年度の分



担報告書の執筆期限は早めで、今年の10月末日です。夏休みを有効に活用してご執筆いただきたいと思います。初年度の執筆者の先生方は、私が付けたコメントを参考にして、項目立ては私の分担報告書に準拠してください。再三強調してきましたが、安衛法をまったく分かっていない人に読みやすい作品を作りたいということです。技術系の人であれば安衛法に親しめると思いますが、文系・事務系の人の中には安衛法を理解できない人も多いため、そういう人たちにも理解できるよう「見える化」を図りたいわけですね。現在公刊されている本の多くは文字ばかりなので、分かる人は読めますが、分からない人はとにかく分からない。多くみられるパターンとしては、法律本法についてわずかに解説が書かれ、その他は関連政省令が羅列されているだけというものです。そのような内容では、親しみようがありません。イメージとしては、医学でいえば「体の図鑑」や「脳の図鑑」といったように、写真やイラストが多用された本です。専門家もそのような類の本で勉強することがあります。現に中災防は職業病関連の本で、そのようなイメージに近い本を出していますし、ボイラーに関する本も、関係団体が図説付の本を出版しています。そういうものも参考にしながら、とにかく図と表を徹底的に使います。ページ数は多くなってもかまいませんし、これは法律文化社からもご了承いただいています。なので、図表を徹底して多用してください。用語解説も、子どもに諭すようにしていねいに行って、いちいちネットで調べなくても本を読むだけでわかるようにお願いします。普段法学者がやっている作業とは真逆の作業を行うという意識が必要になりますので、少々気持ちを入れ替えて執筆に臨んでください。

研究班には、様々な専門性を持った先生方にご参加いただいているので、特に法学者の方は技術系の専門知識を持った先生方に、また監督行政実務の経験があり現場をよくご存知の先生方に積極的に質問をしていただきたいと思います。昨年度は、インタビューなどを個別に実施した方はいましたが、MLを使った質問はほとんど私しかしませんでした。ともかくせつかくの人材の宝庫と言える状況なので、今のままでは非常にもったいないので、いい意味でこれを活用してください。研究班のメンバー以外の方へのインタビューも積極的に行ってください。

また、もう一つ強調したいのは、2年目以降はどこを加筆修正したのか分からないと、二度手間となってしまい、取りまとめに時間がかかってしまいます。そのため、多少の語句の修正にとどまらず実質的に加筆修正した部分について、つまり要約が必要な程度に実質的に内容を加筆修正した部分については、下線を引いて提出してください。逆に削除した部分は下線の引きようがありませんので、コメントを付してどこをどのように削除したのか明記してください。要するに、どこをどう変えたかということがなるべく分かり易くなるようにしたうえで、2年目の報告書を提出していただきたいと思います。これは私が行う作業ですが、逐条解説と横断的課題については、分担報告書を別個に作成しようと思っています。

それでは、本日の本題に移ります。本日は3名の先生方から研究経過報告をいただきたいと思います。先ず藤森先生に、逐条解説ではなく横断的検討課題のひとつをご担当いただくことになっていますので、これについてのビジョンや方向性など経過報告をお願いいたします。

藤森 報告時間が20分程度ということですので、端的にお話したいと思います。資料は3点ありますが、まず「産業用ロボットへの接触に関する規制について」(骨子案)(※以下「藤森資料」)をご覧ください。<問題の所在>の箇所を書きました通り、「産業用ロボットに係る法令・通達等を一つの例として、労働安全衛生法令の構造を横断的に、また体系を縦断的にとらえた解説を行う」予定です。藤森資料には

4つの骨組みを提示していますが、要点を絞って順次説明いたします。

まず1番目は「法令改正の背景・必要性について」、つまりそのニーズについてです。やはり法改正の背景にはニーズがありまして、特に産業用ロボットによる災害の発生のモデルになります。安衛法は昭和47年に制定されたわけですが、その後10年ほど経過してから産業用ロボットが盛んに用いられるようになり、その中で藤森資料の1・①に記載した昭和56年のウラダケースが挙げられます。兵庫県の某メーカーの工場で、産業用ロボットによる死亡事故が起きました。この事件は後日、「日本で初の産業用ロボットによる死亡事故」とされましたが、実際にはそれ以前にも発生しているようです。しかし産業用ロボットとは一体何かという観点からすると、ウラダケースで、これは不幸にして産業用ロボットの整備作業中に被災し、産業用ロボットのアームに接触して死亡した被災者の氏名に由来するものです。当時は産業用ロボットに特化した規制がなく、藤森資料の1・②にあるように、「機械による」危険の防止として一般的な規制として対処せざるを得ませんでした。同じく「災害に発生に対する行政の対応等」ですが、結局2年が経過して1983年（昭和58年）に労働安全衛生規則が改正されるに至りました。産業用ロボットを中心とする法改正の背景・必要性にはこのような事情があったわけですから、1・③として「新たな法規制の必要性及び改正の具体的な流れ」と記載しましたが、可能であればこの辺りも解説しようと思います。

以上を踏まえまして、「2 法令における定義及び適用の範囲について」ですが、これが重要でございまして、特に議論があったように「危険を及ぼすおそれ」、危険性、有害性といったキーワードが出てきます。ここに記載したように「① 法令における「産業用ロボット」の定義と一般の定義(概念)」とを区別する必要があります。なぜこの区別が必要にあるかについてもなるべく分かり易く説明できればと思います。ちなみに、「(参考1) 産業用ロボットに係る法令の適用関係について」(※以下「参考1」)に安衛法第20条を具体化した労働安全衛生規則第36条第31号を掲載しましたが、ここで産業用ロボットの定義がなされています。藤森資料の2・①に書きましたが、「規制の対象としての定義」というのが浮き彫りになってきます。たとえば、広辞苑などをひもとくと、そこに産業用ロボットの定義があります。すなわち、「プログラムあるいはコンピュータの指令によって多様な作業を行う産業用機械。視覚を備え、移動できるものもある。物体の移動、工作機械の操作、組み立てや塗装、溶接などに用いる。」とされています。クレーンやボイラーもそうですが、一般的な定義・概念がある一方、法律上の規制対象としての定義もしっかり押さえておく必要があります。そういう問題にも言及できればと思います。藤森資料の2・①にも書きましたが、有機溶剤に関しては、法律上の規制対象として44種類が定められています。しかし、この世に存在する有機溶剤は44種類だけではありません。にもかかわらず、規制対象としてこの44種類がピックアップされたのはなぜなのか、それを検討することも重要です。

藤森資料の2・②に記載した「適用の範囲の問題」は、現場実務では非常に重要な問題です。言うまでもなく労働安全衛生法は事業者を名宛人とする刑罰法規ですから、事業者が講ずべき措置の対象・内容が明確でなければなりません。一方で、先に言及した内容とも関連しますが、危険性や有害性は相対的なものであって、さほど危険でないものや有害でないもの見極めが難しいわけですが、法律による規制としては定義や適用範囲が定められています。一般的には、能力、大きさ、広さ、あるいは濃さや薄さ、回数、頻度といった観点から規制していくこととなります。それを法規定の上では、適用除外や特例といった形でえり分けることとなります。産業用ロボットについて言えば、藤森資料の2・②に「危険性・有害性(相対的) → 適用除外、特例」と記載した箇所ですが、ここでいう適用除外や特例とは何かという

と、たとえば出力80ワット以下のロボットがそれに当たります。こういうものは、産業用ロボットの定義に該当するものであっても、適用対象から外れます。つまり、出力が大きくなければ危険ではなく、人間の力で押し返すこともできるから問題はなかるうということ。あるいは、大きさの問題や長さの問題などもあり、そういったことは規則、大臣の告示、通達によって「危険が生ずるおそれ」があるかどうか具体化されています。産業用ロボットの規制がその仕組みを知る一つの例になるかと考え、その点についても言及したいと考えています。ちなみにロボットに限らず、電気による災害防止の規定もあるのですが、すべての電気が規制対象となるわけではなく、産業用ロボットの規制と同様の観点で、電圧が50ボルト以下になるような電気機械器具であれば適用除外となります。この点も分かり易く言及するつもりです。なお、50ボルト以下は適用対象外なのですが、たとえば42ボルト(いわゆる「死にボルト」)であっても死亡事故が起きることもあり、また2mの高さ制限が施されているところ、1m(いわゆる「一命とる」)でも死亡事故が起きるケースがあります。こういう場合に、法規制に対する違反が成立しなくても何とかしなければいけない、こういう場合には藤森資料の4で述べるところのリスクアセスメントが求められることとなります。これも産業用ロボットに特化して説明することとなります。

次に、藤森資料の3は「産業用ロボットにおける規制の具体化」ということで、先ほど指摘しました一つの事故をきっかけに、事業者に対する規制として「4M(人・物・作業・管理)による措置」を講ずることが義務づけられました。新たな条文としてはここに記載したのですが(3・①)、これを上手く説明できればと思います。“人”の観点、“物”つまり機械の観点、“作業”の観点、“管理”の観点から、後追いでありながらどのような規制がそれぞれ設けられたのかについても言及したいと思います。3・②ですが、これはロボットに特化した話ですが、事故発生前の時期においては「機械による危険の防止の一般基準」(安衛則101条～111条)があり、それと現行のロボット関連の規定はどのような関係になるのかという重畳の問題にも言及するつもりです。一部のものについては通達等で、新たな規定がないものについては一般条項で、また新しく特別条項で規定したものについては、今までの一般条項は排除されます。そういった法律の仕組みについても分かり易く説明したいと思います。3・②の「産業用ロボットの「機械」としての汎用性」ですが、産業用ロボットは先ほど引用した広辞苑の説明にあるように、運搬、溶接、塗装など様々な用途に使い勝手がよく、汎用性を具備しています。そのため、規制についても特別な取り扱いがあります。ロボット自体は極端に言えば“半完成品”であり、腕から先をいろいろなアタッチメントに変えたり、あるいはシステムとして周辺の関連機器と相まって規制をしなければなりません。そういう新たなニーズがあるということに言及したいと思います。

最後になりますが、「4 これからの安全管理 - 「人とロボットの協働」」です。ここに書いた“協働”は、変換ミスではありません。前にも説明したように、機械的安全には4つの段階があって、これも大切なことなのですが、そもそも危険有害の原因となるものが存在しなくなれば一番いいというのが前提ですが、それがかなわぬまでも、人の安全を十分に確保した上で人とロボットが協働できないか、といったことが言われています。近代になって電気や電子技術が発達して、機能自体を用いて機械等の安全性の確保が重視されています。人と機械を隔離することももちろん大事ですが、安全に関する十分な担保を踏まえたうえでの使用が求められます。人とロボットの協働こそが、その一例となります。

非常に大ざっぱなものでしたが、以上でございます。

三柴 ありがとうございます。藤森先生のご報告に対し、ご質問をいただこうかと思いますが、口火を切

る意味で私の方からいくつかお尋ねしたいと思います。まず、機械安全に限ったことではないのですが、法律本法は一応一義的に“こういう要件が揃えばこうしなさい”と定めているものを、告示や通達やガイドラインといったレベルの規定において縮小解釈させるような、そういう構造を持ったルールというものはあるのでしょうか。

藤森 配布させていただいた「(参考2)「人と産業用ロボットの協働」について」(※以下「参考2」)をご覧ください。先ほどの報告でも触れたリスクアセスメントとも関連しますが、法律本法では、規定の仕方が限定的で、その文言も難解で抽象的な場合があります。労働者に危険を及ぼす「おそれがある」、または「ない」といった書き方をします。そうなってくると、その枠の中で規則、通達、告示、指針といった形で具体的に規定することは差支えありません。その一例がここに記載されています。基本的には、ロボットと接触してはいけないということで、柵や覆い等の接触防止措置を義務づけているわけですが、問題はこの“等”です。法令で「・・・等」という規定がありませんが、この“等”は何かというと、ロボットに限った話ではありませんが、その枠の中で指針や通達などで具体化されていくものです。それは決して範囲を広げるということではありません。特に参考2の2「リスクアセスメントに基づく措置を講じた場合・・・平25・12・24基発1224第2」、そして先ほどの指針の機能安全という概念といった前提を踏まえたうえで、リスクアセスメントを適切に実施してゆくということです。リスクアセスメント自体は、「法律に定めるもののほか」ということで、一步上をゆく先取りの安全を目指すこと自体は、法律の趣旨に反するものではないと考えています。

三柴 安衛法は現場の法であると言われるように、結果を出さなければならない法ですから、制度設計の仕方が難しいわけです。特に、安衛法本法とそれより下のルールとの関係が非常にややこしいのです。そこが安衛法独特のアートでもあります。今ご説明いただいたお話の中で、たとえば危険を生じるおそれに「等」が付されているのは、本法の規定があいまいだからで、それを具体化する意味で告示や通達があるという関係だというのであれば、分かり易いものです。法律があいまいにしている点を、下のルールで分かり易くするのではなく、法律が一応ハッキリと定めていながら、下のルールで解釈の範囲を狭めている。たとえば民法(家族法)を例に挙げると、「夫」という文言がある場合に、“事実婚の夫はその中に含めない”などといった読み方を縮小解釈と言いますが、安衛法の中にそういう例があるかどうかです。

藤森 適切なお答えになるかどうかわかりませんが、あいまいさという点に安衛法規の宿命のひとつがあると思います。ただ、宿命があるからといって解決にはならないので、まさに「危険が生じるおそれ」があるかないか等については、現場でも特に検察庁が立件をするに当たって慎重であり、通達があるか、関連法規がどうなっているか、過去の同種事案があるかどうか等も検討します。

また、たとえば、参考1をご覧くださいなのですが、安衛法第27条で事業者が講ずべき措置の具体的内容等については政省令に委任されているわけです。また、先ほどのお話にも出てきたように、個別の中で労働大臣の指針に基づくといった書き方で、法律自体が委任をしている方式があります。

三柴 法律本法が細かいことは下のルールに委ねるとハッキリ規定してくれれば、委任立法になるとい



うことで問題ないわけです。法律本法はそれなりに独立して定めているのですが、下のルール、それもガイドラインのようなソフトローで読み方を制限してしまうような実例があれば教えていただきたいということですが、それはいったん置いておいて先に話を進めると、法律本法は一般的なことを書いている、悪く言えばあいまいな書き方をしている、それでいて一応の強制力がある下の規則などがその解釈を定めている場合に、法律本法の一般規定は下のルールが定めた範囲でしか適用されないのかという問題もあるわけです。たとえば法律本法は「危険のおそれがある場合」といったように広く規定しているのに、その解釈を具体化する規則などで、「かくかくしかじかの場合がそれに該当する」などと書いてしまうと、これに該当しないものは実際に危険であっても適用ができないという問題が出てくるわけですが、その点はいかがでしょうか。

藤森 先ほどの報告で触れた42Vの例ですが、このような場合にどうするかということですが、法律は罪刑法定主義の観点から厳格に解釈しなければなりません、それでも災害防止が必要になりますから、リスクアセスメントや指針の適用によって補完することになります。そういう観点から、いい意味で幅広く解釈の余地を残すということで、指針やガイドラインの役割があるわけです。42Vであれ、80W以下の産業用ロボットであれ、法令の基準以下だからどうでもいいというわけではなく、そこはリスクアセスメント等の規制を施していきます。

三柴 結局、安衛法の難しさでもあり、面白さでもあるのですが、ルールはきちっと定めなければならない一方で、結果を出すためにはルールだけでは足りないわけで、その穴埋めをどうするかということです。おそらく監督行政の現場実務では、送検する、あるいはそこまでいかなくても指導や勧告をしようという場合には、具体的なルール違反を指摘できないとそれらの権限を行使できないのではないかと思います。その点現場のご経験からはいかがでしょう。

藤森 必要とあれば私以外の行政実務の方からもお知恵を拝借したいところですが、形式的なランクでいうと、使用停止等命令、違反条文を列挙した勧告書、そして指導票、など法違反の再発防止のために実施する広い意味での行政指導などは、ある程度現場の裁量が認められるのではないかと思います。

三柴 もう一点だけよろしいでしょうか。かつて旧労基法時代の安衛則から、いわゆる性能要件を定めている規定があります。つまり、結果さえ出してくれば、ルールに定めたものと違う方法をとってもかまわないという規定です。たとえば機会安全などでも、歯車は歯の大きさが一つにつき何ミリ以上・以下でなければならないといったように、細かい構成要件が定められてはいますが、他の方法を採用した方が上手くいく場合もある、あるいは現実問題として履行が難しい場合もあるので、結果が同じになるのであれば他の方法を採用してもかまわないという規制が、旧安衛則時代からありました。現行の規定もそれを受け継いで、いくつかそのような条文があります。こういう条文は、監督行政の現場で使えるのでしょうか。監督官に専門性がないければ、こういう条文は使いこなせないのではないかと想像するのですが・・・

藤森 よろしければ玉泉先生にもご教授いただきたいのですが、具体的に条文でいえばどの辺りでしょう。



うか。

三柴 玉泉先生、今の問題についてはいかがでしょうか。

玉泉 具体的にどういう条文をさしているのでしょうか？

三柴 そうですね・・・では、また後で触れることにしましょう。

玉泉 安衛則第518条あたりがそうかもしれません。

三柴 はい、確かにそうだったと思います。

玉泉 ケースバイケースで、当該作業に適合した安全帯でもいいし、防網が適切なのか、手すりにすべきなのか、その場の状況に応じて考えざるを得ないと思います。また第519条では、高所作業になるので、木の上で作業するのか、あるいは鉄骨の上で作業するのかによって、講ずべき安全措置の内容はそれぞれ異なってくるので、実際に現場でどういう作業の対策として行っているのかが一番基本になると思います。

三柴 そういった現場を見て、リスクを見積もることのできる力がない監督官に、そのようなルールの適用ができるのか、というのが私が感じている疑問なのですが、いかがでしょうか。

玉泉 ある程度経験は必要だと思います。安全は特にそうです。衛生は学問的な分野なのに対し、安全の分野においては特に経験が求められます。現場を見ていくらの話ですから、現場の経験がないと正しい判断はできません。違反に問えるかどうかは、かなりの経験が必要だと思います。また、三柴先生が先ほど指摘された、通達等で適用範囲を狭めている事例ですが、具体的な物質名は失念しましたが、特化則の中で物質名が書いているのですが、それについて“粉状に限る”とは法令上のどこにも書いてありません。たとえばニッケルであれば、昔は“粉状に限る”などと書いてあったのですが、法文上そういう制限がないにもかかわらず、通達で“粉状に限る”とした解釈が出ています。それはかなり調べないと分かりません。そういった点は、現場で特化則に関連する経験がないと、そこまではなかなか分かりません。違反だと言ってしまう場合もしばしばあります。送検する場合には、“法令の除外事由なく”というのが枕詞として出てきますので、法令の適用除外に該当する解釈や通達などが存在するか否か、克明に調べないと送検できません。したがって、かなりの経験が必要になってくると思います。

藤森 玉泉先生、ありがとうございました。それが先ほど申しました藤森資料2・②「適用の範囲の問題」で指摘した、「・危険性・有害性（相対的）→適用除外、特例」の問題です。先ほども言いました通り、能力、大きさ、広さ、濃さ、回数、頻度などをかなり具体的に定め、先ほど玉泉先生が仰ったように、衛生問題は高度な専門知識が求められるのですが、曝露さえしなければいいわけです。その判断は難しいのですが、安全の問題になると、現場での判断が非常に難しい面があります。安衛則第519条を例に挙

げると、当該安全措置を講じることが作業の性質上困難かどうかについては、現場の監督官が場数を踏んで判断が可能になります。もちろん、人によって判断の違いが出てくるわけで、そこにこの問題の限界があるかと思えます。

三柴 先ほど玉泉先生がご指摘された、相応の経験がないと適用除外の規定がわからないというのは、法律本法の下にあるルールについて純粋に知識が備わっていない、つまりベテランの監督官でないとルールの勉強量が足りず、知識が備わらないということなのか、それともルールの使い方についての機微がわからないという意味なのか、どちらでしょうか。

玉泉 通達や解釈はいろいろなところに出ておりまして、体系立って分からないという点に難しさがあるのではないかと思います。

藤森 注意しなければならないのは、先ほどの藤森資料の「・危険性・有害性(相対的)→適用除外、特例」で申しましたとおり、基本的にはまず法律の枠の中で能力、大きさ、濃さ、回数などの面での適用除外や特例があるということです。そういうきちとした枠組みが、厳然とした形で存在するので、それはまず遵守しなければなりません。その上で先生が仰るような、現場での経験が問われるような場面が出てくるわけです。その点は峻別しなければならないと思います。

三柴 ありがとうございます。他に何かお尋ねになりたい点はありますか。

南 すみません、一点よろしいでしょうか。細かい点で恐縮なのですが、私自身別件の研究でロボット法制について勉強しているところですが、藤森先生から今いろいろとご教授いただきました。その中で、産業用ロボットの定義はどこまで外延が広がっていくのか、私自身よく理解していないところがありまして、産業用ロボットの中に、たとえば「自動的に行うことのできる機械」といった書き方をしているのですが、こういったものが現在ではオートノマスで動くもの、つまりAIなどによって作動するロボットが出てきたときに、それを産業用ロボットと扱っていいのか。あるいは、最後の方で指摘された「人とロボットの協働」についてです。たとえば、ネットワークと連携しているようなものなどは、単に産業用ロボットをその場の指示で動かすだけではなく、遠く離れた場所からネットワークを通じて作動させるようなものも、産業用ロボットの概念の中に含まれていくのかという問題に興味があります。今回のテーマと話がズレてしまうのかもしれませんが、現行法上どこまでを産業用ロボットとして扱っているのかについて教えていただければと思います。

藤森 参考1の1頁目に記載した安衛則第36条ですが、「特別教育を必要とする業務」の規定の中に、産業用ロボットの定義が書かれています。いわく、「マニプレーター及び記憶装置(可動シーケンス制御装置及び固定シーケンス制御装置を含む。以下この号において同じ。)を有し、記憶装置の情報に基づきマニプレーターの伸縮、屈伸、上下移動、左右移動若しくは旋回の動作又はこれらの複合動作を自動的に行うことができる機械(研究開発中のものその他厚生労働大臣が定めるものを除く。以下「産業用ロボット」という。)」とされ、「厚生労働大臣が定めるもの」とは、先ほど申し上げた告示などで80W以下と定め

られているものなどです。基本的には、産業用ロボットの定義はこの規定の通りです。そして、現場で労働者との接触の危険という観点からすれば、単純なひとつの動作を繰り返すだけのロボットなどは定義から除外されます。こうした条文を前提として、ロボットに動作を教え込む段階の問題（教示）、検査や修理の段階、そしてロボットが本来の動作をしている状態の問題、それぞれの場合に労働者に危険を及ぼすおそれをなくするという規定が新たに設けられたわけです。ロボット自体は、システムインテグレーターというか、一個の全体的な関連周辺機器のひとつという意味であれば、ネットワークもそのひとつとして、リスクアセスメントの対象とすべきかと思います。この場合、“ネットワーク”とはどのような意味でしょうか。

南 単純化して言えば、インターネットにつないで作動させるシステムです。従来であれば、ロボットのそばに人間がいて操作することが想定されていたと思うのですが、現在では自宅のエアコンのスイッチを入れるのに、インターネットを通じて行うことができるわけですから、産業用ロボットの場合にはネットワークそれ自体の安全性なども、この枠組みの中で議論すべきかどうかとも少々気になっていたところです。まさに、今私たちはオンラインで通信しているわけですが、もし産業用ロボットをオンラインで操作している際に、通信システムに障害が発生してロボットが異常な動きをするといった事態も想定されるので、そういった問題もこの定義の枠組みの中で議論すべきかどうかということです。

藤森 広い意味での機能安全の中に含まれる問題かと思いますが、私もその点に関しては現時点で詳しいことはお答えできませんので、今のところはいったん持ち帰って、私の方も逆にいろいろ教えていただきながら検討していきたいと思います。

三柴 南さんの質問は大変いい質問だと思います。というのも、安衛法は結果を出さなければならない法規制ですから、趣旨を考えて適用すべきものです。産業用ロボットを特別に規制したのは、動きの複雑さからくる予測不可能性あるいは予測の難しさがリスクとなり、労働者が負傷する事態を防止するためです。なので、ネットワークがそこに絡むことでロボットの動きの予測が一層難しくなるのであれば、趣旨としては規制の対象になるのではないかと思います。安衛法はそういう適用の仕方を昔からやってきています。刑罰法規としての安衛法でさえそうです。一言でいうと、“柔らかい解釈”です。そういうものが非常に重要だということは、ただ今のご質問から想定していただけるのではないかと思います。

吉川 私も最近、建設機械などの関係で産業用ロボットに関連する法規制を調査しているところですが、私の考えでは産業用ロボに該当するのは、そのロボットが働く人（作業員、労働者等）と一緒にいて、働く人に危害を加える可能性がある場合すべてであって、その場合にはいずれも安衛法の規制対象となるのではないかと思います。共有画面に映したのが、「機能安全による機械等に係る安全確保に関する技術上の指針」（平成28年厚生労働省告示第353号、以下「機能安全指針」とする）ですが、機能安全とはPC等による機械の制御であって、これに対する規制をうたっている技術上の指針です。たとえば、産業用ロボットをパソコンやネットワークで制御するという点については、この指針が関わってきます。産業用ロボットを起動させたり、作動させたり、停止させたりなど、操作に関わる部分に制御が入る以上、この指針に必ず引っかかるので遵守義務が生じると思います。やはり機械を作動させ、それが実際に

作動し、危険に接する可能性がある場合には、協調安全ということで、人に接触する前にその機械を停止させる、あるいは速度をジワリと緩めたうえで止めなければなりません。ということで、働く人と同じ場所にいるのであれば、産業用ロボットとして規制の対象になるのではないかと思います。

三柴 ありがとうございます。では、藤森に対するご質問等が他にないようでしたら、先ほどご参加された新任の淀川先生に自己紹介をいただきたいと思います。

淀川 大阪で弁護士をしております、淀川と申します。この度は何卒よろしく願いいたします。私自身まだ経験も浅く、皆さまから勉強させていただくことになると思いますが、ゆくゆくはこのプロジェクトに貢献できるようになりたいと思いますので、どうぞよろしく願いいたします。

三柴 ありがとうございます。では、開催要項「5 研究経過報告」の記載順では佐々木さんにご報告いただくところですが、まだ所用でご参加になっていないようなので、原さんからお願いいたします。

原さんは、今年の秋の労働法学会の大会で、本プロジェクトでもたびたび議論になっている、法令条文等に書かれている「危険のおそれ」の概念に関して、比較法的な観点から報告を予定しています。本日はその調査にかかる経過報告をしていただくことになっています。ドイツは法令における定義付けや体系などについては、日本よりも厳格なので、参考にしやすい面があり、ドイツを参考にされたかと思われます。それでは、お願いいたします。

原 MLで資料を2点配布させていただきました。ひとつは共有画面に映っている「ドイツ労働安全衛生法制における「危険可能性 (Gefährdung)」の概念及びわが国の法令・判例の中に見出される共通項」(※以下「原資料」)で、もうひとつがドイツの安衛法と政省令のうち必要な部分を稚拙ながら翻訳させていただいたものです(※以下「独政省令訳」)。なお、本日唐沢先生よりMLを通じてドイツの労働安全衛生法に関する大変有益な資料をいただきまして、この場をお借りしてあらためて御礼申し上げます。

原資料は5頁ほどの分量になっておりますが、私は本プロジェクトの横断的課題として、安衛則にしばしば登場する「危険のおそれ」あるいは「危険を及ぼすおそれ」の意味や概念を検討する仕事を担当しています。ドイツ法でこれと似た概念を探すと、「危険可能性 (Gefährdung)」という用語が見いだされますが、学会報告では、この概念がわが国の安全衛生法制や安全配慮義務に関連する裁判にどのような影響を与えるかといった点について検討していければと考えています。

まず、ドイツの安全衛生法は *Arbeitsschutzgesetz* という法律が基本法となっておりますが、直訳すると“労働保護法”という意味になります。しかし、労働保護法というと、わが国では労働条件や解雇規制など全般的な労働者の法的保護というニュアンスになりますので、いっそのこと“労働安全衛生法”と意識させていただきました。以下、原資料では“独安衛法”と略称させていただきます。独安衛法は、EC基本指令の国内法化政策等の一環として1996年にドイツで施行され、旧来の安全衛生法制に対する批判を受けて制定されたものであります。この批判はどのようなものかといえば、営業条例 (*GewO - Gewerbeordnung*) を中心とする旧安衛法令は、具体的な危害を及ぼす蓋然性の高い危険 (*Gefahr*) への対処を主たる目的とするものであるがゆえに、労働災害の予防効果に疑問があるとのことでした。このような批判を受け、1996年に施行されたのが独安衛法です。このため、現行の独安衛法は事業者(使



用者)に対し、「危険」だけではなく、「危険可能性（潜在的危険）」（Gefährdung）への対処を義務づけています。両者は何が違うかといえば、危険は具体的な損害の発生が十分な蓋然性をもって客観的に予期される状況であるのに対し、危険可能性は損害・健康被害を及ぼす可能性の段階で、その規模や発生の蓋然性について一定の要件を充たす必要はないとされています。この概念が訴訟に影響を与えたのが、1990年代以降のドイツの受動喫煙訴訟です。ここでは、労働者に具体的な健康被害が生じていない、またこれを立証していないにもかかわらず、使用者に一定の措置（禁煙措置、あるいはタバコの煙が感知されないよう職場環境を整備する措置）を義務づける判断がなされたのは、このような危険可能性に関する考え方が根底に置かれているがゆえのことと評価されています。要するに、タバコの煙というのはそれ自体健康に被害を及ぼす可能性がある、よって具体的に現時点で労働者に何らかの健康被害が生じていなくても、その危険可能性を根絶するのが使用者の義務であると考えられているわけです。

独安衛法第4条は、使用者が安全措置を講じる際に顧慮されるべき一般原則のひとつとして、労働編成の際には「生命及び身体的・精神的健康に対する危険可能性が可能なかぎり防止され、残存する危険可能性が可能なかぎり縮減される」ことを挙げています（第1項）。また危険可能性の要因として、原資料に掲載したとおり、1. 事業場および職場の形成と設置、2. 物理的、化学的、生物学的影響、3. 労働手段、特に原材料、機械、器具、設備およびこれらの扱い方、その選択と投入、4. 労働・製造方法、労働過程、労働時間およびそれらの相互作用のあり方、5. 就労者の不十分な能力・教育、6. 就労に際しての精神的負担、といった就労にかかわる多種多様な物質的・非物質的要因が網羅的に挙げられています（第5条第3項）。そして労働安全措置の内容を策定する前提として、危険可能性の有無・内容を職務態様ごとに判定する義務が使用者に課せられています。ともあれ具体的状況に応じて危険可能性を自ら個々の状況に即して探り出し、それをもとに安全措置を講じなければなりません。独安衛法はそのような義務を使用者に課しています。

ドイツにもわが国と同様、紐付き政省令があります。独安衛法第18条は、連邦参議院の承認を条件に、使用者に独安衛法上の措置義務の内容等を具体化すべく、連邦政府に政令・施行規則（Rechtsverordnung、以下本報告では「規則」とする）の制定権限を付与しています。これに基づいて制定・施行された複数の規則においては、危険可能性は評価ないし判定を意味する“Beurteilung”とワンセットで規定され、使用者に危険可能性判定（Gefährdungsbeurteilung）という措置を義務づけている。これは、唐沢先生からいただいた資料においては、ずばり“リスクアセスメント”と訳されています、その方が訳としては通りがいいかと思われまます。ドイツの各政省令におけるリスクアセスメントの概要は、原資料の1頁から2頁にかけてリスト化いたしました。拙い訳で申し訳ありませんが、独政省令訳に必要な条文を掲載しました。時間の都合上逐一読み上げることはできませんが、内容を大まかにまとめると、原資料2頁、「3、まとめ」の通りです。すなわち、ドイツ法における危険可能性の特徴を2つ挙げると、①具体的な危害発生の蓋然性を要件とする「危険」に対し、危険可能性は科学的・医学的知見等をもとに想定される損害または健康被害を及ぼす「可能性」に過ぎず、具体的な危害発生の蓋然性について一定の要件を充たす必要はない、ということです。この点は近年の受動喫煙訴訟に影響を及ぼし、タバコの煙による具体的な健康被害が立証されていなくても、タバコの煙が健康に対し不可避免的に害を及ぼすという医学的見地を前提に、使用者に対し非喫煙者の就労場所においてタバコ煙の排出が感知されない状態にする措置を講じる義務を認めた判決が見受けられます（連邦労働裁判所2016年5月10日判決）。もうひとつが、②使用者の安全衛生措置の基礎的データかつその克服対象であり、各就労場所に



潜在し就労者の健康と安全に対し危害を及ぼす可能性のある多様な要因で、個々の就労場所の現状や時間の経過によって変化しうるもので、専門的・科学的知見を駆使して使用者が個別に調査・確定を義務づけられるものとされています。以上がドイツ法における危険可能性の本質的内容であるといえます。

この二つの特徴のうち、わが国の安衛法令との共通項を探ってみると、安衛則などの紐付き政省令に「危険のおそれ」という言葉が頻繁に用いられています。このような言葉を、日本の裁判所は刑事裁判でどのように解釈しているかといえば、ドイツ法における危険可能性に関する上記①の特徴とよく似ています。一例として挙げた西田工業事件（最三小判昭48・7・24刑集27巻7号1357頁）は、旧労基法時代の条文が適用された事案ですが、この当時の前身規定には「危険のおそれ」ではなく「危険」という言葉が用いられていました（※下記参照）。

旧安衛則第63条 ① 床面から1.8メートル以内にある動力伝導装置の車軸で接触の危険があるものには、囲、覆又はスリーブを設けなければならない。

安衛則第101条 ① 事業者は、機械の原動機、回転軸、歯車、プーリー、ベルト等の労働者に危険を及ぼすおそれのある部分には、覆い、囲い、スリーブ、踏切橋等を設けなければならない。

これによると、動力伝導装置の車軸に「囲、覆又はスリーブ」を設置しなければならないところ、これを怠った結果、死亡事故を発生させた事業者が刑事訴追された事案です。一審判決（福知山簡判昭45・9・28刑集27巻7号1363頁）は、「本件車軸等は、通常の業務の過程においては、特段の注意をしなくとも、接触等による事故の発生する危険性はないものというべきであり、かような場合に、異常な作業方法または極端な過失を伴う行為による接触の危険を予想して、危害防止の措置を講ずる義務はない」として無罪判決を下しました。しかし控訴審は一転して有罪としています。判旨の中で以下のように論じています。「安衛則が使用者の講ずべき措置を詳細かつ具体的に規定しているゆえんは、「近代的な工場生産が、本質的に、工場で働く労働者にさまざまな危害を与える可能性をはらんでいるので、そのような労働災害から労働者をできるだけ保護するため、危害発生の可能性のある設備につき、危害防止のために必要かつ適切な措置をそれぞれの場合に応じて想定し、その措置を講ずべき義務を使用者に課することとしたにほかならない」。つまり、具体的で明白な危害発生の蓋然性がなかったとしても、その可能性の段階で使用者に義務が生じてくると指摘しています。さらに、「労働者が作業の過程でその車軸（中略）に接触して危害の発生する危険（抽象的危険）の存するかぎり、その車軸に囲い、覆い、またはスリーブを設けるべき義務を使用者に課したもの」であり、「いやしくも作業の過程においてそのような危険の発生する可能性が存するかぎり、使用者は右義務を免れない」と述べています。すなわち、旧安衛則上の「危険」および現行安衛則における「危険を及ぼすおそれ」というものは、決して明白で具体的な差し迫った危険を要件としているのではなく、抽象的な可能性が指摘されるだけで使用者に一定の措置を義務づけるものです。このような点で、ドイツ法の危険可能性の上記①の特徴と極めて似ています。また、次に挙げたX社事件（東京高判平28・11・8高等裁判所刑事裁判速報集（平28）号151頁）では、現行の安衛則第147条第1項が安全装置の設置を義務づけているところ、同規定を次のように解釈しています。「労働者が、作業の過程において、射出成形機等の機械の可動部に近づき、過失の有無を問わず、その身体の一部を挟まれるおそれのある場合をいう」。すなわち、「作業中の労働者が当該機械の可動部に近づく場合を想定し、その際に安全装置を設けることにより、労働者が身体の一部を挟まれるという労働災害を防止しようという趣旨から設けられた規定である」ということです。ともかく、何らかの事情で労働者が近づくという可能性が想定されるのであれば、それで事業者の義務が発生し、決して具体的

な何らかの危険が明白に差し迫っているなどといった蓋然性は要求していません。端的に言ってしまえば、こういう機械には、よほどのことでもない限り原則としてこういう安全装置を必ず設置せよ、ということの規定しているといえます。

第147条 ① 事業者は、射出成形機、鋳型造形機、型打ち機等（第百三十条の九及び本章第四節の機械を除く。）に労働者が身体の一部を挟まれるおそれのあるときは、戸、両手操作式による起動装置その他の安全装置を設けなければならない。

② 前項の戸は、閉じなければ機械が作動しない構造のものでなければならない。

このように、安衛則における「危険」ないし「危険のおそれ」については、危害発生の蓋然性という観点では、ドイツの危険可能性と非常によく似ております。一方で、日本の安衛則では「危険のおそれ」がある状況を予め安衛則でカタログ化してリストアップしているのに対し、ドイツの場合は使用者が個別の事業場ごとに自ら専門的知見を拝借して探り出して確定していかなければなりません。日本の安衛則のように親切にリスト化されているわけではなく、自ら探り出さなくてはならないという厄介さがあります。実は、ドイツの危険可能性のこういう特徴と共通項を備えた規定が、日本の安衛則の中に見いだすことができます。その規定には、危険という用語は使われているものの、「おそれ」という表現は使われていません。原資料4頁「2、危険防止のための調査義務とそれに基づく作業計画・・・②」をご覧ください。ドイツの政省令をみると、危険可能性についてリスクアセスメントを職場ごとに専門知識を駆使しながら、しかも就労開始前に必ずそれを実施・確定し、そのデータをもとに安全措置や作業計画を策定するよう義務付けています。これと近いことを規定しているのが、ここに掲載した安衛則の条文です。第151条の88に、「車両系木材伐出機械を用いて作業を行うときは、当該車両系木材伐出機械の転落、地山の崩壊等による労働者の危険を防止するため、あらかじめ・・・を調査し、その結果を記録しておかなければならない」とありますが、調査と記録はドイツ法のリスクアセスメントの定番で、どの政省令にも必ずワンセットで規定されています。そしてこれに基づいて作業計画を定めるよう、第151条の89が義務づけています。つまり、調査・記録を義務づけているということは、かかる作業そのものの中に危険ないしその可能性が潜在しているということで、それを探り出してから危険がないように作業計画を立てる義務ということなのです。この規定は、危険のおそれという表現は用いていないものの、以上のような観点からドイツ法の危険可能性との類似点が見いだされます。

（調査及び記録）

第151条の88 事業者は、車両系木材伐出機械を用いて作業を行うときは、当該車両系木材伐出機械の転落、地山の崩壊等による労働者の危険を防止するため、あらかじめ、当該作業に係る場所について地形、地盤の状態等並びに伐倒する立木及び取り扱う原木等の形状等を調査し、その結果を記録しておかなければならない。

（作業計画）

第151条の89 ① 事業者は、車両系木材伐出機械を用いて作業を行うときは、あらかじめ、前条の規定による調査により知り得たところに適応する作業計画を定め、かつ、当該作業計画により作業を行わなければならない。

② 前項の作業計画は、次の事項が示されているものでなければならない。

- 一 使用する車両系木材伐出機械の種類及び能力
- 二 車両系木材伐出機械の運行経路

三 車両系木材伐出機械による作業の方法及び場所

四 労働災害が発生した場合の応急の措置及び傷病者の搬送の方法

③ 事業者は、第一項の作業計画を定めたときは、前項第二号から第四号までの事項について関係労働者に周知させなければならない。

以上で触れたのは刑罰規定ないし取締規定の話ですが、他方で安全配慮義務違反など民事裁判ではどのような位置付けや影響がみられるかについても検討する予定です。ご承知のように安全配慮義務の判例は膨大な数にのぼるため、全部調べ尽くしている状況ではないのですが、リーディングケースである陸上自衛隊事件（最三小判昭50・2・25民集29巻2号143頁）においては、次のように述べられています。「安全配慮義務の具体的内容は、公務員の職種、地位及び安全配慮義務が問題となる当該具体的状況等によって異なる」。ドイツ法の危険可能性の概念がまさにそうで、職場ごとに、就労の態様ごとに、あるいは時間ごとに定期的に、具体的状況によって異なるものとされています。最近のうつ病や産業医の関連判決などをみていると、これに近い厳格さを使用者に求めた判決も、民事賠償事件の中にいくつか見受けられるところですが、それらが全体としてどういう傾向を持っているのか、かなり大変な作業になると思いますが、今後の課題として調べていければと思います。

鎌田先生が専門的に研究なさっていた安全配慮義務の履行請求の問題ですが、原資料4頁掲載のJR西日本（安全配慮義務履行請求）事件（大阪地判平26・12・3LEX/DB25446882）では、ドイツ法でいえば危険可能性ではなく「危険」を要件としています。すなわち、「労働者の生命や身体等に対する具体的な危険が発生しているにもかかわらず、使用者において、その危険を放置したり、それを除去するための十分な安全措置を講じないなど、上記具体的な危険に対する使用者の措置がその合理的な裁量を逸脱し、安全配慮義務に違反していると認められる」場合にかぎり、履行請求の権利が発生するというものです。民事賠償と履行請求で、一方では危険を自ら探り出すことまでしないと債務不履行責任になってしまう、他方では具体的な危険が生じているのに使用者がそれを放置してはじめて履行請求権が生じるといったように、両者でこのような違いが出ていますが、これは何に起因するものなのか、などなどといった点を今後の課題として取り組んでいきたいと思っています。

以上、ご清聴ありがとうございました。

三柴 ありがとうございます。先生方から何かご意見ご質問がございましたらお願いいたします。というより、まず私の方から口火を切らせていただきますが、着眼点がよく、面白い調べ方をしていると感じ入りました。ドイツの法制度はきっちりと理屈で整理しようとするのに対し、日本の場合は割と玉虫色で運用するという面があり、比較対象としても適切だと思います。同じような現象が技術的、文化的に起きているのが安全衛生だとすると、そこへのアプローチの仕方の違いには、やはり法文化の違いが顕在化しているのではないかと思います。リスクの考え方については、以前安衛研で国際ワークショップに招かれた際に、私なりに調査・整理してみたことがあります。原さんが報告で指摘していた通り、リスクの考え方や捉え方が違いますし、対処の仕方も異なります。ドイツの場合は、まずリスクを段階化して、リスクの明白であるものと、そうでないもの、“もしかしたら”レベルのもの、といったように3段階ほどに分類し、理論的にリスクを分けて捉えたいうえで、まずは事業者自身に調査をさせます。この調査させるというのが重要であると思います。数多くある職場のリスクをとにかく調べさせたいうえで記録させ、計画をもって対応させるという、理論的に説明のつくやり方をとっているわけです。そして、そこに専門

家を関与させる。ヨーロッパでは職能団体の地位は高いですから、そういう人たちを上手く使うことによって理論的に説明のつく仕組みを回してゆく、というやり方です。もっとも調査や対策を実施するのは、基本的には事業者（使用者）自身です。

これに対し、日本の場合は原さんの報告にもあったように、リスクは公的に決めるものです。言い換えれば、お上が“これはリスクだ”と並べてくれるものがリスクだというのが基本です。そしてその隙間を組織体がチームワークで埋めていきます。ゼロ災運動などがそうで、みんなで盛り上げてチームで災害を減らしていきましようという手法が、かつてはリスクアセスメントよりも主流だったわけです。だから、リスクの捉え方も大きく違い、経営者が眉をひそめそうなリスクについては、あまり重く見積もらないということも日本では起こりやすいようです。

ところで原さんの報告では、ドイツにおいては、リスクは重大なものでなく、また発生の確率は低くても、使用者に対処する義務が生じてくるというお話でしたが、本当にそうでしょうか。そこまで理想的に、大したリスクでなくても事業者に洗い出させて対応させようとしているのでしょうか。

原 やはり根本にあるのは、科学的・医学的知見と研究成果に対する信頼です。現行の科学的水準にそくして、現時点では何事も起きていなくても、ある物質や機械をこういう使用法で放置しておくとも明らかに危険有害なものと判断される場合には、危険可能性を具備するものとして危険が顕在化しないよう対処を求められます。

三柴 その場合の「科学」というのは意味が広く、純粹に物的なエビデンスで裏付けられていて、プロトコルさえはっきりすれば再現性もあるという意味での科学（サイエンス）に限られません。ドイツでいう *Wissenschaft* の中にはコンセンサスも含まれていると思います。そういう意味で、科学という言葉は通常想定するよりも広い意味を持つのではないかと思います。そうはいってもドイツは自然科学を重視している感がありまして、少なくとも理論的に説明できないものは排除する傾向があるので、たとえばストレス問題などはドイツでは他の国に比してあまり論じられることは多くないです。受動喫煙はエビデンスのレベルはそれなりに確証度の高いリスクだと認められれば対処すべき義務が生じるし、裁判所もそのような判決を出します。これに対し、メンタルの問題になると、少なくとも医者が相応の判断を示さないといけないなど、ハッキリした裏付けを要求する傾向はドイツの方が強いのではないかと思います。経験則などに基づいて規制をすると言うやり方は、ドイツではあまり見受けられない気がします。

原 たしかに、メタルヘルス関係の裁判例はドイツで数は多くない気がします。パワハラ（*Mobbing*）が原因で自らが精神疾患を発症し、あるいは夫が自殺して使用者らに賠償責任を迫及する事案も散見されますが、日本に比べると勝訴率は高くありません。その辺は三柴先生がご指摘された通りかもしれません。

三柴 そうですね。唐沢先生はドイツの制度に関して、どのように理解されているのでしょうか。

唐澤 私が研究している範囲内でのお話ですが、三柴先生が仰ったような傾向はあると思います。ドイツでは労働安全衛生は二元制であり、連邦政府と各州で展開する行政と法定の災害保険組合が実施する



労災防止策の二本立てで動いていますので、その両面からみる必要があると思います。

三柴 ありがとうございます。吉川さんは、ドイツの **Bundesanstalt** は行かれたことはありますか。連邦労働安全衛生機構です。

吉川 ドイツはまだ行ったことはありませんが、先ほどのリスクのお話に関して一点よろしいでしょうか。建設業に限ってのお話ですが、想定されるリスクは必ず全部挙げることになっています。そうしてすべて挙げたうえで、大・中・小あるいは5段階評価をして、リスクの大きいものから順にその低減措置を検討していくことになっています。場合によってはリスクが1ないし“小”と言う場合もありますが、そのような場合にはリスク低減のための対策は講じません。いずれにせよ、想定されるすべてのリスクは全部列挙することとされています。

三柴 そうですね、まずは網羅的に調査をして土俵に載せるということが重要な点です。それを記録して、なんとか対処していこうという考えです。要するに科学的な検証の準備作業ということですね。

吉川 そうです。リスクの大きさに応じて対応策を考えていくことになります。なので、リスクが小さければ特に何らかの措置を講じる必要はないわけです。

三柴 その点割り切りが強い感じですね。整理したうえでリスクの小さいものであれば、放置するわけです。そうなってくると、ストレス問題のようなものは、捕捉されないんです。

吉川 ただ、最近ヨーロッパの会議などに出ていると、安全よりも衛生に対する関心が強まっているようです。

三柴 筋骨格系の問題などに関しては80年代くらいから注目されるようになり、衛生面に関心が強まっているのは、今に始まったことではありません。ただし、衛生面での判断は言うなれば占いと紙一重という側面があり、心理的リスクなど問題は主観と紙一重なわけです。そのため、問題としてこれを補足するのはなかなか難しいところがあります。

吉川 過労死（**Karoshi**）という日本語が残念ながら国際的に有名になってしまいましたが、こういう問題への取り組みは、今後ドイツでも盛んになっていくのではないかと思います。職場のストレスの問題も同様でしょう。

三柴 鎌田先生もご存知かと思いますが、かつて来日したオリバー氏は過労死問題の研究が目的で日本に来ました。私も彼に付き添って日本の判例を紹介したりなどしていましたが、その後彼は著書を書きまして、日本の過労死をめぐる判例状況を公刊しました。ドイツの人たちも関心があるようですが、自分たちで何らかの対策を講じるかといえば、未だに対ストレス規則は完成していません。草案はできています。ドイツ社民党が奮闘していましたが、議会で可決されるに至っていません。



ところで佐々木さん、精神面での賠償論に関して言えば、ドイツではまずまず進展がみられたところでしょうか。解雇保護に関しては精神面での賠償請求は可能でしたよね？

佐々木 解雇保護については、少なくとも私がこれまで検討した事案では、賠償請求が本題になっているというよりは、当該解雇が有効か無効かという形でその正当性が争われるものを中心なので、賠償に関しては詳細は存じておりません。

三柴 精神的なストレスが生じたから賠償問題になるとか、あるいは解雇が緩和される、あるいは厳格化されるとか、そういう方向にはなっていないのでしょうか。

佐々木 私の知る限りではそういう方向にはなっていないようです。

原 よろしいのでしょうか。ドイツでは、立証責任の問題が立ちはだかってきます。精神的ストレスの原因がはっきりと特定できない場合に、やはり立証責任は訴えを起こす原告側に課せられるものです。そうになると、うつ病や自殺の原因は何かを証明することは容易ではありません。しかも、パワハラ訴訟においては非常に厄介で、それ自体では法に触れないような嫌味や当てこすりなどといった加害行為が、ジワジワと精神を追い詰めていったときに、因果関係を立証することはほぼ不可能ですから、精神疾患がらみの賠償請求がなかなか認容されないのも、その点に大きな要因があると思います。

石崎 今のお話に関連するかわかりませんが、ドイツでは労災保険において精神を病んだとしても職業病とは認定されず、事故類型で拾えるかどうかで決まってくるようです。ストレスが蓄積してそれが病気の発症の原因となるという発想があまりないような気がします。フランスでは、もともとはドイツと同様事故として捉えていましたが、専門家の認定を受けることで例外的に職業病と認める道筋も開け始めているようです。しかしドイツでは、まだそういう認識があまり共有されているとは言い難いという印象があります。

三柴 ご指摘のように、フランスは精神的ストレスについて民事の賠償責任でも労災補償の方でも門戸を開いているようで、「重大な過失」の解釈を広げることで対応しているようです。他方、ドイツはまだそこまで開けてはいないみたいですね。

石崎 先ほど原先生がご指摘されたように、精神的ストレスに対する賠償を認めるとすれば、職場いじめ (Mobbing) の事案かと思います。

三柴 ハラスメントの問題は突破口になるかもしれませんね。結局、科学を重視するからといって、リスクを大きく拾えるとは限らないということです。リスクの捉え方は、文化的な背景を背負っているのではないかということは意識すべきではないかと思います。イギリスは安全衛生では世界的に進んでいると言われていますが、豊澤先生がかの国の安全衛生の研修を受講してみたら、日本の研修の方がよほど精密だったと仰ってました。理屈はきれいに整理されているからといって、痒いところにまできちんと

手が届いているとは限らないということです。

吉川 豊澤先生がイギリスの講習に参加された際、向こうの人に“なぜ来ているのか”と尋ねられました。というのも、イギリスに言わせれば、“われわれの方こそ日本から学ぶべきなのに”というのです。

三柴 確かにそんなこと仰ってましたね。法律家はどうしても言葉ばかりみるもので、実態や背景にあるものを探ろうとはしません。なので、リスクは低くてもきちんとアセスメントするとなると、どうしても日本よりも進んでいるように見えてしまいます。しかし、必ずしもそうとは言い切れません。

吉川 イギリスを見て思うのは、法規制や規則を作るのは上手です。イギリスは、まだ実態がないにも関わらず、組織作りや規制作りを実現してしまいます。それに対し、日本の場合はきちんと実態を積み上げて周囲が対応できるようになってはじめてルール作りをしています。そういう、元々の文化の違いが色濃く出ているのではないかという印象を受けます。

三柴 ドイツでも、サイエンスで認めないものを一切排除しているわけではなく、コンセンサスをベースとするリスク対応も行っています。先ほど唐沢先生が仰ったように、安全衛生制度が二元化していて、監督行政のラインと社会民主国家らしい自治的なラインで、労災保険組合 (Brufsgenossenschaft)・・・日本でいえば中災防や労災防止協会に該当する組織ですが、そういう団体が労災補償もあわせて実施しています。日本でいえば労災防止団体に該当する組織が、予防と補償の両方を担っています。半官半民のような組織で、労使双方がそれぞれ代表を出し、総会を開催し事務総長を選出するなどして運営していく仕組みになっています。だから、労使が納得すればストレス問題も対応は可能なわけです。ただ、災防団体は研究機関を保有しているし、そういう機関の研究成果をまるっきり無視して勝手に占みたいルールを作るようなことはしません。ただ、一応危なさそうだとということが科学的に仮説でもいいから出され、社会民主的な構造の中で労使が納得すれば予防法はできます。それでもやはり未だ捕捉されていないリスクというものは多々あると思います。

原さん、その点は文字を追うだけではなく、もう少し背景にある事情を検討した方がいいかもしれません。

原 今お話をうかがっていて、確かにその通りだと思いました。科学や医学に対する信頼というものは、裁判の中にもよく表れておまして、確立した現行の医学的知見は法令とほぼ同じ扱いを受けます。たとえば、ドイツにおいては安全配慮義務の具体的内容を確定する際に、安全衛生法規のような公法的な取締規定はそのまま契約上の義務内容とされます。いわゆる安全衛生法規の“二重効”といわれるものです。実は、二重効によって契約の義務内容に含まれるのは、現行の安衛法規だけではなく、将来安衛法規として結実する可能性のある科学的知見なども実質上法規としての扱いを受けます。つまり、使用者の安全配慮義務の内容は、現行の安衛法令プラス現在芽としてふき出している将来の安衛法令も、民事裁判では顧慮されます。そういう判例もドイツでは散見されます。

三柴 法律家以外の方にはやや分かりにくい部分もあったかもしれませんが少々言い直しますと、日本ではJ I S規格あるいは日化協のような業界団体が出すガイドラインや規格がありますが、こういったものがそのまま法的義務になるようなものです。産業認識であったり、科学的研究の前線に近いところであったり、ともかく専門家が危なそうだと思ったものはいち早く法令に取り入れて対策を講じさせようという法体系になっているのがドイツ法です。ドイツの科学や学術の最前線を *Arbeitswissenschaft* といいます。この文言がドイツの法令の中には頻繁に用いられます。日本の安衛法ではご承知のように、J I S規格も一応は援用され、これを参照している条文はありますが、数的にはごくわずかです。たしかに科学の前線や科学者のコンセンサスと法規範の距離が、ドイツでは非常に近いといえます。

石崎 今の点ですが、日本でも裁判例における安全配慮義務の解釈においては、安衛法の規定だけではなく、科学の知見が基準とされる事案もあったと思うので、それをドイツの特徴と見るか否かについては慎重な検討が必要かと思われま。

三柴 おっしゃる通りで、発生した災害事故の後始末である賠償の問題になると、日本の場合は裁判所が筋読みをして、使用者がその気になればできることがあったのに、それをやらないまま発生した災害だったということになると、後付けとして産業認識や最先端の知識を踏まえるべきだということを経験は唱えてきました。しかし、例えば受動喫煙や時代的に救済を施すには時期尚早という問題については、“アバウトな問題”ということで片付けてきました。言わば判例は二枚舌と言えます。ただ賠償請求の場合は後処理であるがゆえに、これと思う人に対しては賠償をさせるための理屈の中でかなり厳しいことを述べています。問題は予防です。予防の面では、日本の法規は先端をすくい上げるような書き方はあまりしません。監督官の方もよほど経験豊富で鼻が利かないと、現場で臨検する際にある機械が危害を及ぼす可能性を指摘するのは難しいと思われるし、あるいは梯子等の危険性やリスクを察知して指導するのは、今の体制では難しいかもしれません。法規もそれを支えるような構造になっているのか、なっていないのか、その辺も突き詰めていきたいと思えます。

鎌田 一点、原さんに質問よろしいでしょうか。労働安全衛生法についてドイツと比較検討され、特に危険可能性という概念を対象に検討されています。そして民事損害賠償あるいは履行請求の事案を例に出され、そこで「抽象的危険」ないし「具体的危険」という言葉を通じて、ドイツの危険可能性とパラレルに置き換えて説明されたと思うのですが、そういう理解でよろしいでしょうか。

原 はい。ご指摘の通りです。

鎌田 特に安全配慮義務違反に基づく損害賠償の理論を考えた場合、危険というよりも、損害発生の予見可能性の問題であるといえます。これはどこの基本書や教科書にも書いてあることですが、安全配慮義務違反とは損害発生の予見可能性、そして予見できた場合にこれをいかにして阻止すべきかという損害回避措置を講じなかったことと、発生した損害との間の因果関係が肯定されて賠償責任が生じます。こういう確立した枠組みがあるわけです。そうすると、先ほどのご報告で、ドイツ法の危険、危険可能性と日本法の抽象的危険や具体的危険とパラレルに、民事損害賠償の話でそのまま用いると、今までの教

科書知識を持っている私などからすると、少々違うのではないかと感じてしまうのですが、その辺はいかがでしょうか。

原 たとえばある事件で、労働者がうつ病で真っ青な顔をして元気もなく、異常な言動がみられるようになり、彼が自殺するという結果を予見することが可能であったと判断された場合、その後使用者が何をして、何をしなかったかが問題となります。その際に、最近の判例は割と使用者にヘビーな義務を課すものが見受けられます。

鎌田 いえ、私が言いたかったのは、危険が発生してどのような義務内容かを確定する前の段階の話です。原さんのご報告では、危険があるから義務が生じるという発想なのかと思いますが、その危険と言われるものは、伝統的な賠償理論だと損害の予見可能性とって、加害者側の予見可能性の問題です。ですから、別に抽象的危険とか具体的危険などといった概念が、そこにストレートに入るわけではありません。

原 つまり、予見可能性というのは、使用者は知っていながら、あるいは知り得ていたのに何もしなかったという責任ということになります。要するに、誰が見てもこの人は危ない、あるいはこの人は放置しておくで死んでしまう、といったことが分かっているながら、なぜ何もしなかったのかという話ですね。

鎌田 もちろん、予見可能性が肯定される場合には義務が発生するので、なぜ何もしなかったのかという問責が生じることにはなりますが、そもそも危険というものを意識していたのかどうかという認識、つまり予見可能性という話が必ず入ってくるわけです。

原 その場合の予見といった場合、結局は危険を予見するということになります。仮に全然危険ではなくても、具体的状況からしてこの人は死んでしまう危険があると誰もが予見できるような場合であれば、債務不履行責任が出てきます。

鎌田 つまり、危険というものは、別に認識や意識をしなくても客観的に存在するわけです。しかし、賠償論を考える場合には、予見可能性とは常に加害者の認識の問題になるわけです。原さんがそれを取り払って考えるべきだと主張するのであれば、それはそれで一つの考え方ではあると思います。ただ、それをそのまま民事賠償論に持ち込むのが原さんの考え方ということなのではないでしょうか。つまり、予見可能性という概念が入ってこないということでしょうか。

原 予見可能性という日本の安全配慮義務違反の有無の判断のやり方の中に、実はドイツの危険可能性と共通項となる部分があります。というのも、もし予見ができる状況になったときに、どのように結果を回避するか、そういう危険が生じる結果を察知した使用者が、何をすべきかという裁判所の指示や問責の仕方は、使用者が自ら潜在する危険を探り出すべきというドイツ法の発想と重なる部分があると思われま。

三柴 途中ですみませんが、法律論的にマニアックになり過ぎてしまっている感がありますのでこの辺で。私なりに整理させていただくと、鎌田先生のご示唆は、予防法の議論と賠償法の議論はきちっと分けて整理して検討すべきだということかと思います。ドイツ法の危険可能性というのが、安衛法のような予防のための法規と、不法行為や債務不履行のような賠償法のための議論と、それぞれに位置付けるとどのような意義を持つのか、適切に整理して論じるべきかと思います。一点だけ申し添えておきますと、おそらく予見可能性といっても抽象的予見可能性と具体的予見可能性に分けられますが、具体的予見可能性は要件事実論的には個別事情を汲むということですから、ここに深く関わってくることになると思います。この点は少々話がマニアックになるので、ここでは割愛します。いずれにせよ、予防と賠償の議論はそれぞれ分けて、それぞれの要件をきちっと考えたうえで、危険可能性の概念をどう位置付けるかを論じてください。鎌田先生のご発言の趣旨はおそらくそういうことであると思われま

鎌田 その通りです。予防論というのは、まさにリスク評価とか客観的にどう考えるかといった課題であると思います。

三柴 ありがとうございます。一点指摘できることといえば、ドイツは両者を結び付けます。原さんが指摘したとおり、予防法に違反したら民事損害賠償責任を負うという仕組みになっています。

鎌田 安全配慮義務の場合、営業法に基づく予防措置をそのまま民法618条（ドイツ民法における安全配慮義務の明文規定）に取り込むものですから、ドイツではそもそも履行請求も可能なわけですが。日本の場合は、これとは少々異なります。マニアックなお話で恐縮です。

三柴 原さんはその辺りの違いも踏まえながら、予防法と賠償法を分けたうえで、共通するなら共通するで、手順を踏んで説明するよう心がけてください。

原 はい、わかりました。大変貴重なご指導ありがとうございました。

鎌田 原さん、横から大変失礼いたしました。

原 いえ、大変参考になりました。ありがとうございました。

三柴 では、佐々木さんにご報告いただく前に、少々休憩とします。



三柴 では、再開させていただきます。本日の開催要項の最後になりますが、佐々木先生からご担当の条文に関する調査の進捗状況についてご報告をいただきたいと思っております。

ところで、先ほどのお話に戻って恐縮なのですが、鎌田先生は安全配慮義務の研究では第一人者で、労働法学においても大変なインパクトのある学説を、数々の論文を通じて提唱されてきました。特にドイツ法との比較研究を非常に丹念に続けてこられたということはお伝えしておきたいと思っております。また、安全配慮義務だけでなく、労働者派遣、業務委託のような三当事者間の労働関係についても重厚な研究成果を示して来られました。

では、佐々木さん、資料を画面共有した上でご報告お願いいたします。

佐々木 それでは報告を始めさせていただきますが、資料（※「佐々木資料」とする）の送付が遅くなりまして大変申し訳ありませんでした。私は、安衛法第22条および第23条を担当させていただくことになっておりまして、現在の進捗状況と今後取り組むべき課題についてまとめた内容を報告させていただきます。

第22条 事業者は、次の健康障害を防止するため必要な措置を講じなければならない。

- 一 原材料、ガス、蒸気、粉じん、酸素欠乏空気、病原体等による健康障害
- 二 放射線、高温、低温、超音波、騒音、振動、異常気圧等による健康障害
- 三 計器監視、精密工作等の作業による健康障害
- 四 排気、排液又は残さい物による健康障害

第23条 事業者は、労働者を就業させる建設物その他の作業場について、通路、床面、階段等の保全並びに換気、採光、照明、保温、防湿、休養、避難及び清潔に必要な措置その他労働者の健康、風紀及び生命の保持のため必要な措置を講じなければならない。

まず、第22条と第23条がどのような条文かということですが、安衛法第1条にいう危害防止基準のうち使用者に義務付けられた具体的な行為基準の定めたものです。特にこの二つの条文は、ご承知のように特別衛生規則が非常に密接に関わっている条文であり、これらについて検討しているところです。両条文は、必要な措置を講じる義務を抽象的に課しているだけで、その具体的内容は政省令に委ねられている部分が多い規定なので、現時点で佐々木資料には反映できていないのですが、各関係政省令を深掘りする作業を進めているところです。ただ、未だご報告できるような形でまとまっていませんので、安衛法の条文についてお話するにとどめたいところですが、本プロジェクトは三柴先生から何度もお話がありました通り、過去の厚労科研のプロジェクトと連続性があるということです。以前の厚労科研の報告書を拝読させていただきましたが、連続性を抽出できる点があるとすれば、佐々木資料1頁の〔元監督官へのインタビュー調査の結果〕です。そこでは、「日本の現行安衛法制度は、規制等も含めた体系全体としては、その綿密さや過去の災害等を踏まえた実践的な有用性、事業者への威迫・強制性などの点で優れている」としながらも、安衛法の条文それ自体には具体的内容が記載されていないという特徴があります。今後の課題としては、「法律本法とそれに連なる法体系を分かり易く整理し、法律本法を見れば、事業者らがなすべき基本的な事柄が分かるようにする」というようにまとめられていました。今回私が担当した条文は、安衛法および11の衛生関係の特別規則が密接に関連してくる問題であるので、特に前回の厚労科研の研究で明らかになった課題と直面するところではないかと感じております。

ということで、今回の逐条解説のなかで、第22条・第23条の検討は当然行うべきものであるととも

に、関係政省令との関連および規則ごとの深掘りを可能な範囲で進めていきたいと思っております。また、前回の厚労科研の報告が指摘しているところの、規定の複雑さをどのように解消すべきかという問題も検討できればと思っております。現時点では第22条と第23条に関連する問題を、解説書などを参照しながらまとめていますが、【沿革】などは既存の文献のまとめを基礎に、もう少し参考文献等を用いて肉付けができると思っております。特に、藤森先生が作成して下さったカラーの一覧表に赤字で記載されている政省令の解説や適用の実際などを調査しているところです。また、裁判例のなかにも政省令を援用しているものがあるので、それらを収集して検討しています。

安衛則は、おそらくすべての安衛法上の条文と関わってくると思われそうですが、これ以外の特別規則は、私の担当条文については佐々木資料4頁以下にほぼすべて書かれています。私が検討すべき規則は少々深掘りした方がよろしいかと考え、ご覧のように各規則ごとにまとめた次第です。ただ、沿革や制定に至る背景となった災害について、文献を集めて読んでいるところですが、その辺りを第22条の解説に含めて書くべきか否か、つまり安衛法本法の解説はこの辺にとどめておくべきか、あるいは各政省令をもっと遡って検討すべきかについて、少々迷っているところです。現在苦心しているのは、【適用の実際】です。三柴先生もかなり重視している箇所のひとつかと思っておりますが、佐々木資料7頁に引用した「労働基準関係違反に係る公表事案(令和元年6月1日～令和2年5月29日公表分)」をみると、第22条違反は全国で1年間に9件とかなり少ない件数で、なおかつそれが必ず「第22条と安衛則」あるいは「第22条と酸欠則」といったように、政省令とワンセットで違反が摘発されています。このように、件数の少なさが悩みどころで、他にどの資料やデータを当たれば具体的な事案を知ることができるのかが問題です。この資料は、一覧表になっているだけで、具体的な状況を知ることはできませんので、場合によっては新聞記事のデータベースを使って調査すると記事として掲載されていることもあります。ただ、この件数の少なさから、どのように実態を把握すればいいのか、よろしければお伺いしたいところがございます。

第23条もほぼ同じような構成です（佐々木資料8頁以下）。同条も、かなり抽象的な定め方になっていて、この解説も当然行っていくわけですが、ここでは事務所衛生基準規則(事務所則)が関わってきます。これら第23条の政省令も同様に検討していきたいと考えています。当然、事務所則の背景や沿革も調べなくてはならないと思うのですが、この規則の【適用の実際】はさらに難儀しそうで、違反が年間2件しかありませんでした。これを過去にさかのぼって、どれだけ違反事例を見つけ出すことができるのか、少々不安に思うところです。また、「通路」の定義が問題となった事件があり、安衛則第540条違反の事例です。こういった点を調査していきたいところですが、【適用の実際】という、本プロジェクトでも重要なポイントがなかなか調べるのが難しいというのが悩みどころです。

時間の都合上、個々の詳細部分につきましては、ご質問があればお答えするという形にしたいと思っております。現状としては、安衛法第22条、第23条に関連する各規則のうち、重要な条文については趣旨や内容をまとめる作業を進めています。各規則の中で、たとえばかくかくしかじかの作業をする際にはどのような措置を講じよ、あるいは防護具はこのようなものであるとか、一目でわかる図や写真などを探しつつ、深掘りをしているところです。この点、三柴先生から送っていただいた開催要項の中で、横断的課題の【追加案】の箇所に「特別規則の成立経緯、趣旨と基本構造、統合の可能性」という案が出されていますが、これが衛生関係の規則を指しているのであれば、私が取り組もうとしている課題と繋がってくるのではないかと、その点をお伺いできればと思っております。横断的課題については、まだ私は担当箇所を割り当てられていませんので、衛生関係の課題であれば、今取り組んでいるものと並行してできるのでは

ないかと思えます。

さらに課題としては、担当条文は数多くの規則が関連するため、整理の仕方をどうするかです。また、前回の厚労科研で指摘されたところの、「安衛法本法のみでは非常に分かり難い条文である」がゆえに、「これらを分かりやすくするために提言できることはないか」という点に踏み込んで検討すること、あるいは規則全体を通した横断的検討ができないだろうか、などなど考えているところです。また、【適用の実際】を書く際に、件数が少ないうえに具体的状況をうかがい知るための資料がなかなか出てこないで、その点の調べ方についてご教示いただければ幸いです。

概要は以上の通りです。

三柴 ありがとうございます。ご報告をうかがって、誠実に調べていただいていると感じ、ありがたく思っています。実は、私も佐々木さんと同じことを感じていまして、今の衛生関係の特別規則はごちゃ付き過ぎて分かりにくいです。なので、なんとか本プロジェクトが上梓を目指す体系書の中で、特別規則相互の関係性やそれぞれの特徴といった点はなるべく端的に示して、どういう問題であればどの規則を当たるべきかについて、読み手が分かるように書きたいところです。新たに横断的課題として、「特別規則の成立経緯、趣旨と基本構造、統合の可能性」というテーマを設けたのですが、誰がこれを担当すべきだろうと思っていたところです。しかし、今のご報告をうかがっていて、衛生関係については佐々木さんをお願いできそうだと思います。ただしこれは、ベテランの方、特に監督行政実務や角田先生のようなコンサルティングをなさっている方など現場に近い方、それと規則を作られた唐沢先生のような制度設計者の方にご協力を仰がないと立体的な情報になりません。ですから、佐々木さんには規則についてインタビューを実施していただきたいです。まずは本プロジェクトのメンバーの先生は、安全衛生行政実務に関する人間国宝なので、こちらの先生方にインタビューをしてください。そして、インタビュー先の先生が“このテーマについてはこの人が詳しい”などと紹介して下さった場合には、その方に当たってください。このようにして、文献だけではなく、人からの情報獲得にも努めてください。

ところで、石崎さんはテーマとしては近い問題を担当されていますね。

石崎 はい、そうですね。

三柴 下手な協力関係を取るとかえって互いにごちゃついてしまうので、そこは慎重を期す必要があるのですが、情報の交換は可能でしょうか。

石崎 そういう意味でいうと、確かに作業環境測定を検討する中で事業場の有害因子の問題を第65条の解説で書きたいと思って書いていましたが、第22条の解説とかぶってしまうかもしれないと気になっていました。なので、書いたものを共有するというのであれば、メールでやり取りするだけで可能ですから、その点は大丈夫です。現在書いている最中なので、適宜分担できればと思っています。

三柴 統括者としては互いの調査結果がハイブリッドになり、相乗的な形に仕上がってくるとありがたいです。単にいずれかが担当を決めて丸投げにするのではなく、担当者双方が調査して、極論すれば二人とも同じ文章を執筆してもいいんです。まあ、それでは芸がありませんから、お互いに調べた点

は共著のような形で、コラムのように枠でくくって、両方がその箇所を参照してくれるような形で進めていただくと内容が充実します。そういう形は統括者としてありがたいと思います。この点については、石崎さんがリードする形で佐々木さんと共同していただけないでしょうか。

石崎 了解しました。私自身も調査執筆が遅れているところがありまして、十分に進んではいないのですが、現時点で仕上がっている部分については共有したうえでご相談させていただければと思いますので、ぜひよろしく願いいたします。

佐々木 こちらこそよろしく願いいたします。

三柴 玉泉先生にお尋ねいたしますが、特別規則の現場での捉え方などについて、インタビューなどお引き受けしていただけるでしょうか。

玉泉 了解いたしました。先ほど佐々木先生が指摘されましたが、適用の実際の件数が少ないのは、送検事件に限ってのことです。監督署による送検は全体で1000件程度で、その半分は労基法違反で、残り半分は安衛法違反で、そのほとんどが死亡事故に絡んでのことです。なので、衛生関係での送検数は少ないと思います。「労働基準監督年報」が公刊されていますので、そこに各条文ごとの臨検監督の結果が掲載されています。そこには石綿則や有機則の条文ごとにおそらくデータが出ていると思います。なので、臨検監督については、労働基準監督年報をみれば件数はもう少し詳細にわかると思います。インターネットでも検索できます。その他の点については、私もお協力させていただきます。

佐々木 ありがとうございます。よろしく願いいたします。

三柴 藤森先生は、この領域についてはいかがでしょうか。

藤森 玉泉先生にご一任いたしますが、私も必要とあればご協力させていただきます。安衛法第23条に関しては、騒音、振動、腰痛のような作業関連疾患は把握が難しいので、政省令の中にはこれらに対応する単発の規則がありません。その辺の関連性などについて疑問が生じれば、ご相談いただければと思います。

佐々木 その点についてですが、たとえば振動による手の病気や難聴などについても調べていましたが、そういった話も盛り込んだほうがよろしいでしょうか。

藤森 第23条はそういう関係の話が出てきます。そもそも安衛則で規定しているわけですから、その辺の絡みもあると思います。その辺りのお話は、また機会があればということで。

三柴 佐々木さんは、玉泉・藤森両先生にお話しをうかがってみてください。それと、唐沢先生、制度設計をされたお立場で、佐々木さんからのインタビューを受けていただけますでしょうか。



唐沢 三柴先生のアシスタントの宮田さんから Web 上で送っていただいた『政策担当者が語る 労働衛生施策の歩み』という本がありますが、その中に参考となる記述があります。主に化学関係の規則について触れたものですが、鉛中毒予防規則や有機溶剤中毒予防規則等々の制定の経緯などが書かれています。私も共著者の一人ですが、宮田さん作成にかかるデータベースの中にあると思いますので、まずはこちらをご覧ください。かなりの情報が記載されています。

三柴 まず佐々木さんとしては、今示していただいた資料をみて、疑問点があればそれをまとめて唐沢先生にたずねるという手順でいかがでしょうか。

佐々木 了解いたしました。よろしくお願いいたします。

三柴 もし必要があれば、石崎さんがインタビューされた先生にもお聴きするという場合もあるかもしれませんが、その際には石崎さんと相談してください。いずれにせよ、文献資料に限らず人からの情報を入手することによって、情報の質を高めていただきたいと思います。

では、最後のひとつになりますが、安全関係の規則の趣旨や関係性について、技術系に強い方で書ける方をどなたかご紹介いただけないでしょうか。この場でなくても結構ですので、元監督官や行実務経験の方が相応しいかと思います。角田先生も含め、これと思う方がいらしたらML等でご紹介いただければと思います。衛生関係の規則については、佐々木さんが石崎さんと協力しながら執筆して下さるということになりましたが、安全関係で同様の作業をしてくださる方が必要なので、できれば行政実務の方で技術に強い方で、書けそうだという方がいれば、この場でなくても結構なのでご紹介いただけるようお願いいたします。

次回の会合は8月6日（木）、その次は9月10日（木）ということですが、締切まではこの2回の会合で終わると思います。可能であれば、久しぶりに厚労省で対面による会合を開きたいところですが、状況が変わらなければまたZoom会議ということになります。

本日予定していた内容は以上ですが、最後に一言ご発言がございましたらよろしくお願いいたします。平岡先生いかがでしょうか。

平岡 今日の会合は大変勉強になりましたし、自分自身も土砂崩壊に関する研究をまとめたいと考えておりますので、引き続きよろしくお願いいたします。

三柴 阿部先生はいかがでしょう。

阿部（未） 私も自分の担当箇所についてあまり手をつけていませんが、会合でのお話は大変勉強になっています。ありがとうございました。

三柴 角田先生、お願いします。



角田 私は相変わらず現場ばかりまわっているのですが、現場で法の適用以前の段階で危険の判定を行うことも多いです。安衛法が現場で実際にどのように使われているのか、ご質問いただければと思います。どうぞよろしく願いいたします。

三柴 ありがとうございます。次回あたり、角田先生に現場の知見、つまり現場を見回って法令との関係でどのようなことを実感されているのか、などといったお話をしていただければと思います。田中先生はいかがでしょう。

田中 皆さんの色々なお話をうかがって、自分自身どのような方向で研究を進めればいいのか、次第に分かるようになりました。今後ともよろしく願いいたします。

三柴 石崎先生も先ほど少々お話しいただいたところですが、最後に今一度お願いいたします。

石崎 いつも色々勉強させていただいてありがとうございます。実は、自分自身の進捗状況があまり芳しくないのですが、今後夏休み等の時間もありますので進めていきたいと思っています。また、南先生とおって相談できればと思うのですが、作業環境測定協会のヒアリングがコロナの影響でまだ実施できておりませんので、様子見ながら再調整などもはかったうえで、9月頃に依頼できればと考えています。

三柴 できれば佐々木さんも同席させていただければと思います。

石崎 はい、ぜひそうさせていただきます。日程調整の際にはご連絡いたします。

佐々木 よろしく願いいたします。

三柴 旅費は科研の方から出ますので、その点は宮田さんにご連絡ください。それでは、本日も長時間にわたって大変有意義な議論をありがとうございました。本日はこれにて終了とさせていただきます。

三柴 早速ですが始めさせていただきます。すでにお送りした開催要項にしたがって進めさせていただきます。まずは、新任の委員の先生のご紹介から始めたいと思います。最初に浅田先生ですが、元々は安衛研の監事や労働局長など行政ご出身の先生で、現在は社会保険労務士をなさっています。安全衛生に関して大変な関心、そして知識と情報をお持ちです。今回特に、安全関係の特別規則についてご解説をいただく予定でご参加いただくことになりました。では、浅田先生、ひと言お願いいたします。

浅田 ただ今ご紹介いただきました浅田でございます。今回の参加は、畠中先生を通じて代表者の三柴先生にご紹介いただいたことがきっかけです。三柴先生からは本プロジェクトが目指すものとして、一つには労働安全衛生法のしっかりした体系書を取りまとめて、現在分断されている法律と現場実務の架け橋を作ること、二つ目には労働安全衛生法の発展のために人的ネットワークを構築すること、と伺っております。その大変高邁な理想に感銘を受けまして、何らかのお役にたてればと参加を決意した次第でございます。三柴先生は以前から存じ上げていましたが、労働安全衛生研究の第一人者で、幅広く論文等を執筆されています。ぜひ一度一緒させていただきたいと思っておりました。私自身は、先ほどご紹介いただきましたように、行政官として労働安全衛生法の施行に携わっておりましたが、厚生労働省では安全衛生部に勤務しておりました。平成17年の労働安全衛生法の改正作業にも取り組んだことがあります。現在は、特定社労士や労働衛生コンサルタントをつとめております。皆さまと比べて、遅い時期からの参加となりますので、おそらく追いついていくのに精一杯で、どれほどお役にたてるのか一抹の不安は感じますが、できる限りの努力はしていきたいと思っておりますので、皆さまのご指導をお願いする次第でございます。

三柴 ありがとうございます。続きまして、高木元也先生です。現在は安衛研で建設安全研究グループの部長等をおつとめで、このプロジェクトでは主に中小企業の建設安全についてご解説いただく予定です。高木先生、ひと言よろしく申し上げます。

（通信障害のためか、音声が届かず）

音声が届きませんので、大変恐縮ですが高木先生のご挨拶は後にさせていただくこととして、長谷川先生のご紹介をさせていただきます。長谷川先生は私と同じく労働法学者で、現在専修大学におつとめです。特に障害者雇用の問題に力を入れて調査研究に取り組んでこられた経緯がありまして、本プロジェクトでは化学物質の管理に関する条文の逐条解説をお願いする予定です。長谷川先生、ひと言お願いいたします。

長谷川 ただ今三柴先生からご紹介いただきました専修大学の長谷川と申します。前回の会合からお誘いをいただいておりましたが、所用のため欠席させていただいて失礼いたしました。今私が取り組んでいるテーマについては、三柴先生からお話しいただいたとおりで、労働法、特に障害者の問題について研究に取り組んでまいりました。今回勉強させていただく安衛法やその中の化学物質の問題は、私も素人でございます。本プロジェクトに何か貢献するというよりも、おそらく先生方に様々な教えをいただいたり、勉強させていただくことの方が多くなるかと思いますが、なるべくこれまでの先生方の研究の流れを追ったうえで、何がしかの貢献をさせていただければと思います。どうかよろしく申し上げます。

三柴 ありがとうございます。それでは次に、新任の先生方もご参加ですので、逐条解説の分担を再確認させていただきます。すでにMLで配信させていただきましたが、開催要項の分担案にしたがって逐条解説の作業を進めていただきたいということです。新たにご確認いただきたいのは、分担者は黄色い帯で示していますが、黄緑色で示しているのが新しい情報です。まず逐条解説に当たって、行政実務ご経験の先生から現場の運用実態についての情報を得ていただきたいということです。本プロジェクトの逐条解説の項目立てでいうと、【適用の実際】という呼び方をしている箇所です。これに関する情報は、監督行政実務、特に安全衛生に詳しい先生方にご参加いただいているので、重ねて申し上げますが、そうした先生方から情報を入手してください。

第4章については、当初の予定よりも分担者を分割して細分化しておりますので、あらためてご確認をお願いします。第5章の第2節は長谷川先生にお願いすることになっております。安衛法の条文では第55条から第58条の部分です。化学物質の規制ですが、上手く規制して被害を防ぐのがなかなか難しいところがあります。本質的には製造や流通段階で規制する方が災害を減らしやすいので、そこに手を入れるような規制・・・化学物質対策の中でもかなり本質的な規制を企図するものです。安全衛生規制の特徴の一つは、現場の労使だけに任せていたのでは上手くいかない場合が多いということです。危険な化学物質から生じる災害を防ぐには、“上流”つまり製造段階あるいはこれを流通させる段階で規制する方が上策で、この点は環境や公害規制と類似しています。このような規制について調査し、具体的な解説に務めていただければと思います。

第7章は、当初石崎先生に単独でお願いする予定でしたが、阿部未央先生に加わっていただき、その一部を分担していただくことになりました。第8章については、今回ご欠席ですが行政学専門の大藪先生に分担をお願いしています。ただ、危険有害業務に従事する人に資格を求めるという趣旨の規制なので、安全衛生免許関係に詳しい方から情報を入手していただくのがいいと思われるため、大藪先生ご自身の人脈からそういう人に当たっていただくことにしています。第10章の「監督等」については、鎌田先生と田中先生の共著という形で分担報告書を送っていただきました。これから私が確認した上で、修正のお願いを差し上げる予定です。第11章の「雑則」については、大藪先生と山本先生にお願いしています。そのうち山本先生にお願いする分担箇所は、健康譲歩の取扱いに関するところで、そこは労働法学者による法解釈論的な解説が必要となる問題ということで、山本圭子先生にお願いすることにしました（山本先生からチャットにて「11章につき了解いたしました」とのメッセージあり）。以上が分担案の再確認です。

次の議題に移りますが、今年度の調査研究方針の再確認です。逐条解説を分担される先生方には各自の分担箇所の作業に取り組んでいただくこと、また今年度は新たに・・・森先生には昨年度から取り組んでいただけていますが、それ以外の先生には横断的課題について分担研究をしていただきたいということです。横断的課題とは、開催要項「6 横断的検討課題と担当者の選定」に列挙したもので、それぞれ担当者も決まっています。森先生以外の方には今年度から取り組んでいただくようお願いいたします。逐条解説が縦割りだとすると、横断的課題というのはそこに横串をさすように、複数の条文にまたがるような課題ということになります。現在および今後の安全衛生規制と実態に鑑みて重要と思われるものを、先生方のご意見を踏まえてピックアップさせていただいた次第です。これらの調査研究の成果について、逐条解説を担当される先生方におかれましては、逐条解説とは別個の分担報告書を作成してください。

横断的課題用の分担報告書は、分冊として別立てにする予定です。すなわち、逐条解説用の冊子と横断的課題用の冊子と、別々の冊子にする予定なので、それぞれの分担報告書を別個に作成していただくようお願いいたします。先ほども申し上げましたが、逐条解説ご担当の先生方は、各条文がどう使われているという【適用の実際】を調査する際に、せっかく本プロジェクトに行政監督実務の経験者の先生がご参加ですので、積極的にその知見をうかがってほしいということです。今後、個々の先生方による個々のインタビューとは別に、このプロジェクトとして監督官や元監督官の方に量的・質的な調査を実施たいと思っておりますが、個々の条文の詳細を拾うまではいかないと思います。それぞれの担当条文に関する詳しい現場情報を各担当者が得ていただくようお願いいたします。プロジェクトとしての質的・量的調査については、藤森先生らのご助力をいただいて進める予定です。

初年度に、日本の安全衛生実務者向けの社会調査を実施しました。たとえば、経営者が安全衛生を重視しているのか、重視しているとすれば、あるいはしていないとすればその理由は何か、などといったことを調べましたが、イギリスでも同様の社会調査を行う予定です。イギリスでそのような調査を実施するうえで、こういうことも質問してほしい、などといったご要望があれば私宛ないしMLにお寄せいただき、メンバーで共有を図ってください。いずれにしてもこのプロジェクトは、安衛法に関する適切な体系書をつくるという狙いを持っていますので、分担研究者の先生方全員が同じ質量の情報を共有したうえで、それぞれの調査研究に当たっていただきたいと思っていますので、ML等を活用して情報の共有に務めてください。

また、初年度と方針を変えた点があります。全メンバーが、自分自身が保有している知識・経験を披歴していただくという方針に変更しました。それぞれの方が有益な知識・経験をお持ちなので、本日もそうであるようにそれを会合で披露してください。もし会合を欠席された場合は、必ずZoomの録画またはペーパー化された議事録をご確認いただいて、全メンバーが進捗状況をフォローし、同じレベルで調査研究を進めていただくよう改めてお願いいたします。

分担報告書の執筆要領に話を進めますが、**今年度の分担報告書の提出期限は早めで恐縮ですが、今年度の10月末厳守でお願いします。**締切日を早めたのは、分担研究者の人数が多く、私が全員分の報告書をチェックして必要な修正箇所について各担当者とやり取りをしなければならないからです。20数名ご参加ですので、それを全部チェックさせていただいたうえで、修正のためのやり取りをしなければなりませんので、どうしてもこの時期までに提出していただくことになります。ただ、必ずしも各分担箇所の完成原稿を仕上げるという意味ではありません。分担報告書は“現在ここまで進みました”という経過を示していただき、来年の3月頃までに完成原稿を仕上げていただくことになります。まだ完成に至っていない部分については「未了」と書いていただければけっこうです。分担報告書の体裁・様式は私の分担報告書にならってください。初めて執筆される先生方におかれましては、項目立ては私の分担報告書をコピーして、ご自身の報告書向けにアレンジしていただくのが便利ではないかと思っております。初年度に分担報告書を提出していただいた方には、私がコメントをつけてお返ししています。そのコメントへのご対応がまだ済んでいない方もおられますので、あらためてご参照したうえで2年目の分担報告書の作成に当たってください。また、何度か申し上げたところですが、今までよりも多くの人に安衛法を知ってもらうことがこのプロジェクトの目的のひとつです。要するに、技術屋による技術屋向けの法律という性格の濃かった安衛法は、メンタル問題など現在社会的な側面を広げています。なので、これを事務系・文系の人たちにも理解していただく必要があるわけです。また安全衛生自体がリスク管理という本質を有



していますが、リスク管理の手法というのは機械安全や建設安全のような伝統的な安全衛生における知恵の集積を、健康や衛生に活かせる側面もあるわけで、両者を同じやり方では通用しないことも多々あるものの、リスク管理という意味では共通しています。そういう意味で、技術屋が構築してきたルールの体系を文系・事務系も知ってゆくことが必要です。なので、ページ数を気にすることなく図や表をとにかく多用していただきたいと思います。この点についても私の分担報告書をご覧いただければ一目瞭然で、鎌田先生ご提出の報告書も、私の方からお願いして図表を多用していただいています。法学者の方は、法解釈が上手くいけばそれでよし、あとは遵守しない人が悪い、といったスタンスで済ませてきましたが、それ以外にそのルールがどういう使われ方をしているのかといった点まで責任もって検討していただきたいわけで、そうしないと安全衛生を保つことはできません。極論すれば、安全衛生というのはルールを遵守しなくても結果的に労災を減らせばいいという面もあるくらいの現場論なので、各ルールの現場での使われ方について、せっかく生き字引のような先生方がお揃いなわけですから、ぜひ活用してください。インタビューなどを積極的に行っていただきたいということをあらためて申し上げます。最近注目されている安衛法第69条のような健康関連の条文は、監督官にとってどのような条文で、安全衛生に関して意識の高い監督官がどういう指導を行い、逆にあまり意識の高くない監督官であればどういう使い方になっているのか、場合によっては衛生関係はチェックリストを作って、指導票のように事業場に交付しただけで終わりなどといった話も耳にします。ルールが現場でどのように使われているかは、やはり現場の人に聴かないと知り得ない情報がたくさんありますので、そういう点をきちんと捕捉していただきたいということです。なお、昨年度の報告書を改訂して今年度の報告書を作成される先生方におかれては、チェックの必要がありますので、下線を引く等の方法で加筆修正を施した箇所が分かり易くなるようお願いいたします。削除した箇所はコメントをつけて、削除した旨を明記してください。

では、いよいよ本日のメインイベントである研究経過報告に移らせていただきます。まずは高木先生から中小企業の建設安全の研究経過報告をお願いしたいと思います。あらためて高木先生の方から自己紹介をいただけないでしょうか。

高木 初めまして。共有画面に映りました通り、労働安全衛生総合研究所において労働者の安全と健康を確保するための研究に取り組んでいるところでございます。本日は通信環境が非常に悪く、私の声も途切れ途切れになるかもしれませんが、何卒ご容赦ください。私自身は土木屋なのですが、この研究所の中では中小企業の安全というものが大きなテーマとされてきました。主なフィールドは建設業ですが、そのほか陸上貨物や運送業、港湾貨物、製造業、最近では小売業、飲食業、漁業など広範囲なフィールドをみながら、現場の実態を明らかにして課題を出して、解決策を見いだしていきます。そして、その解決策を労働安全衛生行政に反映させるといったストーリーで研究を重ねてきました。そして、（・・・通信障害・・・）これまでの研究成果で中小企業の安全確保をどう進めてゆくのかについてお話ししたいと思います。



### 中小規模事業場の労働災害が多い

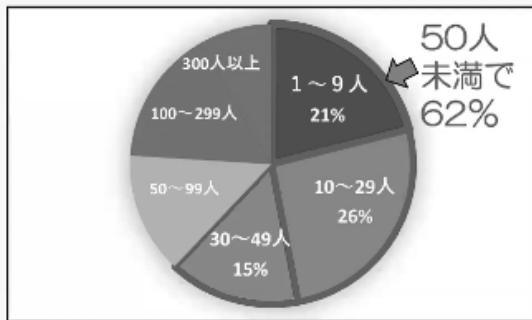

資料：厚労省「労働者死傷病報告」  
 図1 全産業の事業場規模別死傷災害発生状況 (H29)

・建設業の中小規模事業場における中小企業の死亡災害発生割合は、8割近く(H18, H19)を占める。  
 資料：厚労省「労働者死傷病報告」

・労働者数50人未満の事業場は、300人以上より、3.4～4.0倍も高い。

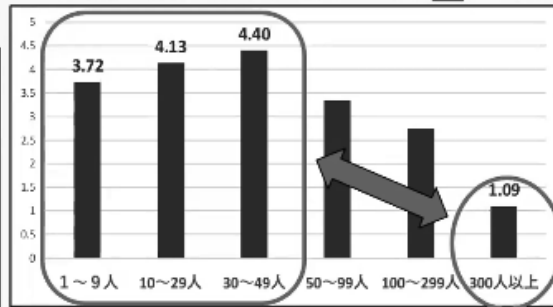

資料：厚労省「労働者死傷病報告」  
 図2 製造業の事業場規模別死傷年千人率 (H29)



図3 建災防会員・非会員別死亡災害発生割合 (H25)

・非会員の死亡災害が約8割を占める。  
 資料：建災防「平成25年度会員の状況」

高木 まず、「中小規模事業場の労働災害が多い」ということは皆さんご承知かと思われませんが、左側の図1をご覧ください。これは全産業の事業場規模別死傷災害発生状況 (H29) のデータです。50人未満の中小規模の事業場が62%を占め最も多いということですが、ただひとつ留意しなければならないのは、この人数は労働災害が発生したときに死傷病報告に記載される人数なので、必ずしも中小企業に限られるわけではないということです。たとえばゼネコンの清水建設や鹿島建設のような2兆円近い大きな企業であっても、たまたまその現場が着工間もないとき、あるいは竣工間際で現場に人が少ないときは「中小規模事業場」に該当してしまうということで、この点留意が必要です。その下に、「建設業の中小規模事業場における中小企業の死亡災害発生割合は、8割近く (H18、H19) を占める」(・・・通信障害・・・)2割くらい多いだろう、逆に大規模の事業場でも中小企業があるということに留意ながらも、だいたい8割近くになり、建設業においても中小企業が多くを占めているということです。右側上の図は、事業場規模別にみた「千人率」、つまり労働者1000人当たりの災害発生率ととらえてください。図2のグラフにあるように、1～9人、10～29人、30～49人の事業場は発生率が3～4人、一方300人以上では1.09人ですから、これにくらべると中小規模の事業場の発生率は高いことを示しています。本日中災防の方もお見えになっていますが、現在の私の問題意識として、災防団体の会員以外の方の災害が非常に多いということです。図3は平成25年の建設業の労働災害防止団体である建災防会員・非会員別死亡災害発生割合のデータですが、非会員の死亡災害が約8割を占めており、今後こういった点が課題になるということを示すグラフです。

## （建設業） 死亡災害は長期的には大幅減

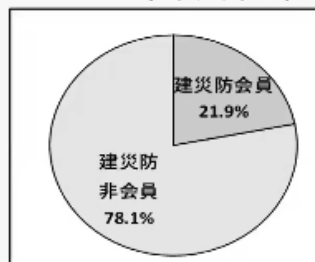
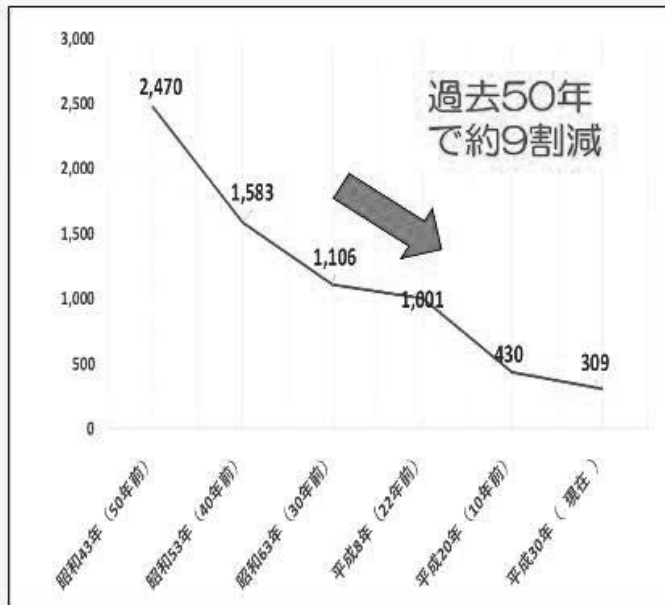

### （減少要因）

- ①労働安全衛生法規等、規制強化（S47安衛法制定他）
- ②元請業者主導の自主的な安全活動推進・定着（H8以降の減少）
  - ・安全の施工サイクル、安全の基本ルール、効果的な安全教育
- ③安全性能が向上した機械、設備、工具等の普及

3

高木 グラフは過去50年の建設業の死亡災害を示したのですが、建設業全体をみると50年という長期間のうちに9割減っています。9割も減った理由は、グラフの下に書いたように、①労働安全衛生法が昭和47年に制定された直後の4年間に一挙に4割も減りました。これは明らかに法規制の効果であると思われます。しかし、建設業においては50年代から冬の時代となり、労働災害が全く減らない時代となりました。しかし平成8年に1001人、これが1000人台を記録した最後の年になりましたが、それ以降雪崩のように減っています。これをどう解釈するかということですが、②元請業者主導の自主的な安全活動が推進・定着しているのではないかとことです。ちょうど、自主的な安全活動というのは、政策としても平成(・・・通信障害・・・)厚労研とみても言えるのではないかと、こういう安全の施工サイクルや現場のルールを設けてそれを実践するようになったとか、安全教育がしっかりしたなどといった面があります。さらに、機械に着目すると、安全性能が向上した機械、設備、工具などが普及して災害が減ってきたという事情もあります。この50年をみていると、以上のような流れになります。

三柴 高木先生、先ほどの資料でいう②の部分が通信障害で聞き取れず、重要なお話だったので今一度ご説明をお願いします。

高木 申し訳ありません。元請業者主導の実施も、平成7年くらいでしょうか。私はその時に建設業関係の財団に在籍していましたが、建設省、国土交通省、厚労省を交え、もっと規制をかけていくべきか、あるいは事業者の自主的な安全衛生活動を促進させるべきか、といった議論があり、世界に目を転じてみると労働安全衛生マネジメントシステムのような自主的な安全活動を促進する法制が出ていました。それならばということで舵取りをして、ゆくゆくは平成18年のリスクアセスメントの努力義務化につな

がっていると思います。その当時から現場では、規制を遵守するのは当然として、同時に規制を遵守するための前提として安全の施工サイクルや現場のルールを定めたり、効果的な安全教育をするようになりました。安全教育でいえば、雇入れ時教育という法定の教育があります。しかし、それ以外にも月例の教育や危険予知トレーニングなどを積み重ねていったのが、(・・・通信障害・・・)建設工事が減ったからという意見もありますが、それは50年の長期スパンで見るとまったく当てはまらないという理解をしています。そして③が安全性能が向上した機械、設備、工具が普及してきたということですが、たとえばクレーンではリミッターという一定以上の物を吊ると、それ以上は吊れなくなる過負荷防止装置を取り付けるなど、安全水準が向上した機械を使うようになりました。このような要因もあると思います。

## 最近の死亡災害の傾向

### ・安衛法規対象の事業場

①大がかりなもの（例：50人以上の事業場、高さ10m超の足場）

②危険有害作業（例：高所作業、有機溶剤取扱作業）

→最近の法定特別教育（墜落防止、足場組立）は効果ありと考える

→（林業）昨年8月1日、改正労働安全衛生規則の施行

主な規制の内容：①受口を作る必要がある立木の最小直径の拡大（40cm→20cm以上）

②伐木時の退避距離の定め（立木高さの2倍以上）

令和2年6月8日現在、伐木作業の死亡者数は対前年比同数。

ただ、今後、発注者が規制を踏まえた積算にすれば死亡者数減が期待

### ・最近の死亡災害の傾向（2つのタイプ）

①規制が順守されない

・例：墜落制止用器具（安全帯）使用せず

②規制の対象ではない

・浅い溝掘削（深さ1.5m以下）の土砂崩壊

・2t・4tトラック荷台上からの墜落

・脚立、はしご等用具からの墜落

（H26：高さ90cm脚立、墜落死亡）

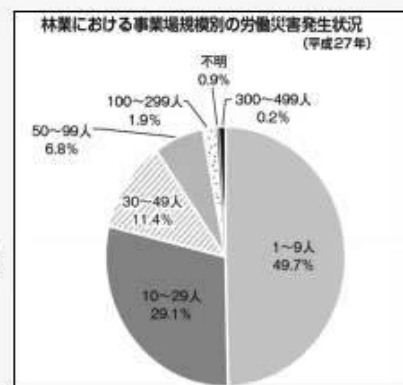

高木　そして、最近の死亡災害の傾向です。今日の安衛法規対象の事業場の特徴をざっくり言えば、①大がかりなもの、そして②危険有害作業です。①の例としては、50人以上の事業場には統括責任者を配置しなければならないとか、高さ10m超の足場では計画届を提出せよなどで、②の危険有害作業にも規制がかかっています。最近は墜落防止や足場の組立については、法定特別教育を受けなければ作業に従事できないとか(・・・通信障害・・・)、特別教育を受けなければ足場が組めないといった効果があります。林業でいえば昨年の8月1日ですが、改正労働安全衛生規則が施行されました。主な内容としては、木を伐るときに、「受口」・・・つまり木は一方向からスパッと切るわけではなく、向かい側に受口を切るわけです。その受口を作る必要のある立木の最少直径を40cmから20cmへと、もっと小さな木にも規制を及ぼしました。もう一つは、伐木時の退避距離については木の高さの2倍以上という内容を規則の中に定めて規制をかけました。ただ、林災防が出している令和2年6月8日現在、つまり規制をかけ



て10か月を経た時点での死亡者数はあまり変わっていないというのが現状です。ただ、長い目で見ると、規制をかけたあと、林野庁などの発注者が規制を踏まえた積算、すなわち40cmの径から20cmの径へと事業者に負担を強いるわけです。もっと時間かけて(・・・通信障害・・・)その下の「最近の死亡災害の傾向」は、これらの規制が遵守されていないこと、たとえば墜落災害は墜落制止用器具が使われていない状況を示しています。さらにもう一つ、規制の対象ではないものですが、これは大きな問題です。たとえば、浅い溝掘削の土砂崩壊とか、あるいは高さ1mもないトラックの荷台や、90cm程度の脚立からの墜落です。これらは規制の対象外ですが、やたらと多くみられます。相対的にみて、規制対象となる労働災害が減っている一方、今まで規制の対象外として手つかずだったところがまだ残っているわけです。こうした災害が大きな問題のひとつとして挙げられます。右側のグラフは、平成27年の林業における事業者規模別労働災害発生状況ですが、他の産業よりも50人以下の事業場における災害発生件数が一層高くなっています。

## 中小企業の安全確保に関する先行研究 (3つのタイプ)

### ①外部支援の充実

Peter HASLE他：2006 (デンマーク)、Aoife Finneran他：2014 (イギリス)、 Luise Vassie 他：2000 (イギリス/スペイン) 等

### ②中小企業に適した安全活動促進

Tom Papworth：2015 (イギリス)、Kirsten Jørgensen他：2011 (デンマーク) 等

### ③経営者クラスの安全意識向上

Peter HASLE他：2006 (デンマーク)、Aoife Finneran他：2014 (イギリス) 等

- 研究結果例：政府機関、労働組合等公的機関による外部支援の効果が高い。

### 解決すべき問題の構造

- その他、建設工事の場合、中小企業の水準に応じた工事の提供がある。

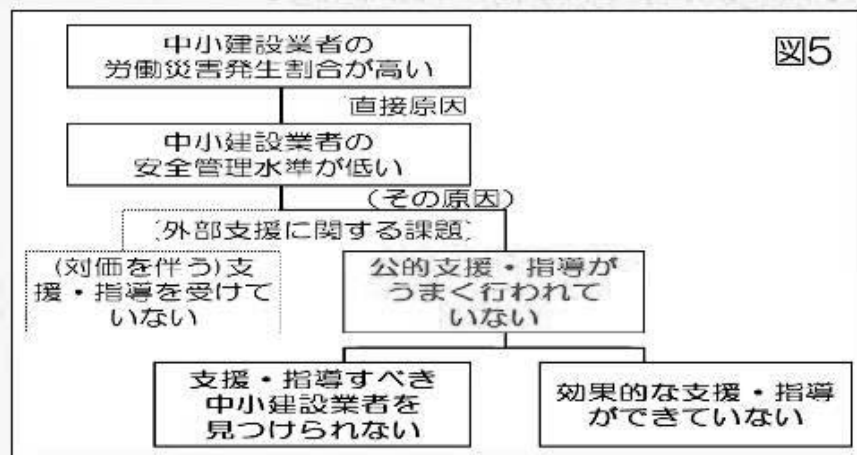

5

高木 次は、中小企業の安全確保に関する先行研究 (・・・通信障害・・・) いろいろな論文をみていると3つに分けられます。すなわち①外部支援の充実、②中小企業に適した安全活動促進、③経営者クラスの安全意識向上、です。これらをまとめて言うと、中小企業に適した安全活動の促進や経営者クラスの安全意識の向上は自助努力では難しいので、外部支援の充実に尽きるのではないかという構造になっていると思います。その下ですが、ではこういう問題をどうやって解決するのかという「解決すべき問題の構造」を示しました。最初にお話したように、中小建設業者の労働災害発生割合が高い、その原因としては、安全管理水準が低いということです。しかし、では安全管理水準が高まるかといえ、それが高まらない

ことを前提に、外部からの支援が必要となるわけです。そして、対価を伴う支援を受けるのに必要なお金を出す余裕がない、そうすると公的支援・指導が必要なわけですが、それがうまく行われていない（・・・通信障害・・・）公的支援・指導がうまく行われていないのはなぜかといえば、図の下の方にあるように、効果的な支援・指導ができていないというのは当然の理由です。もう一つ、左側にあるように、支援・指導すべき中小建設業者を見つけられない、つまり指導する側が見つけれられていないということです。これは非常に大きな問題です。ともあれ、その2つに分けられます。左側にある「その他」ですが、建設工事の場合、安全管理水準が低かったら、逆に安全管理水準が低い事業者でも安全にできるような事業場を、公共工事の場合に発注者側が提供するというのが解決すべき構造のひとつにあるのではないかと思います。

## 建設業の「労働安全行政施策」

(根拠となる行政通達)

労働基準局長通達「建設業における総合的労働災害防止対策の推進について」(平成19年)等

### 1) 指導の基本方針のひとつ

→労働災害防止団体、関係業界団体、発注者、労働安全行政による一体的推進

### 2) 工事規模別による指導

①超大規模建設工事、②大規模建設工事、③中規模建設工事、  
④小規模建設工事

### 3) 小規模建設工事(上下水道等)の指導の重点事項

→安全衛生管理の充実(元請業者による安全教育推進等)

→通常の工事現場(事業場)単位は困難なことから、施工業者単位での指導

6

高木 建設業の「労働安全行政施策」についてですが、根拠となる行政通達としては、平成19年の局長通達である「建設業における総合的労働災害防止対策の推進について」が現在もメインになっています。指導の基本方針のひとつに（・・・通信障害・・・）労働安全行政は小規模に分けて指導していきなさい、特に中小は元請による安全教育の推進や、基本的な労働安全衛生は事業場単位ですが、小規模なところでは事業場単位では困難なので、施工業者単位での指導をしなさい、といった内容が定められています。



## 中小建設業者の公的支援・指導に関する研究

- 本研究は、中小建設業者に対する労働安全行政施策に基づく労働安全行政、関係業界団体、発注者による公的支援・指導の実態を調査し、公的支援・指導がうまく行われていない具体的な課題を明らかにした。
- 研究の対象は、小規模建設工事（上下水道）、発注者は公共工事発注者、関係業団体は専門工事業団体



図6 行政施策における工事規模別指導区分より

7

高木 そういう背景をもとに、中小建設業者の公的支援・指導に関する研究を行いました。先ほども言いましたが、対象としては小規模、発注者、公共工事、関係業界団体、専門工事業団体について図6にあるように建設工事を規模別に分け、小規模の中でも公共工事を対象として調査しました。

## 研究の方法

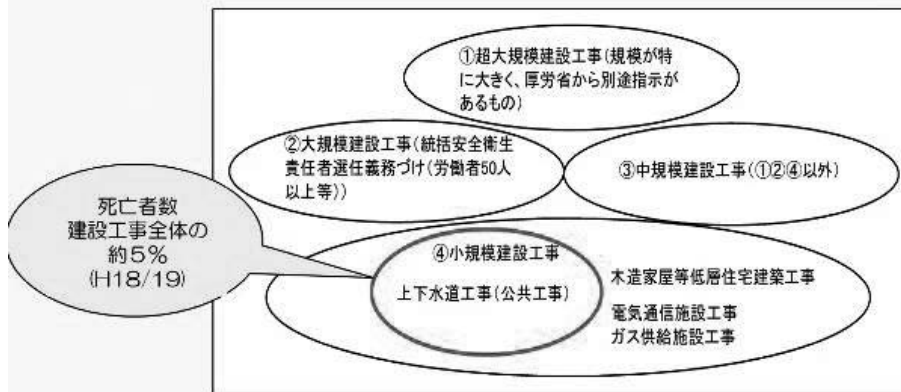
- アンケート調査（5種類）
  - ①②管工事業対象の安全教育等の実態調査（2種類）
  - ③都道府県労働局、④公共工事発注者（地方自治体）、⑤専門工事業団体対象の支援・指導の実態調査
- 海外文献調査：欧米諸国の労働安全衛生行政施策の事例調査
- ヒアリング調査：労働安全行政経験者対象
- 国内文献調査：労働基準監督署の指導、公共工事発注者の法的責任、国が推進する発注者の安全配慮に関する調査等

## 論文の構成

- 第1章：研究の目的等
- 第2章：中小建設業における安全教育の実態把握、課題の抽出
- 第3章：労働安全行政における指導の実態把握、課題の抽出
- 第4章：欧米諸国と比較したわが国の労働安全行政における中小企業施策の課題の抽出
- 第5章：公共工事発注者における支援・指導の実態把握、課題の抽出
- 第6章：専門工事業団体における支援の実態把握、課題の抽出
- 第7章：抽出された課題相互の関連の分析
- 第8章：まとめ、今後の研究課題

8

高木 研究には12～13年かかっていますが、アンケート調査を5種類実施しました。また、海外の文献調査、さらには労働安全行政の経験者にヒアリング調査、また国内文献調査も実施しています。これを

論文にまとめたものを章立てで示したのが「論文の構成」ですが、限られた時間の中で各章の内容を簡潔に説明させていただきます。

## 第2章 中小建設業の安全教育上の課題の抽出

- ・労働安全行政施策に基づく事業者が講ずべき措置の基本事項の一つである「安全衛生教育の推進」を対象に、管工事業者（小規模な上下水道等建設工事）の安全教育の実態調査を行った。

### 全国管工事業協同組合連合会会員対象アンケート調査

調査対象：安全講習会（全国計30）の受講者。回答者は元請・下請における管理者・技術者、職長、作業員、一人親方等

調査時期：2014年8月～2015年10月

### 回答者の属性（回答者数1,171人）

表2 所属業者従業員規模別

	回答者	
	人数	割合
15人以下	252	21.5%
16～30人	304	26.0%
31～50人	335	28.6%
51～100人	98	8.4%
101～300人	52	4.4%
301～1000人	23	2.0%
1001人以上	32	2.7%
不明	75	6.4%
合計	1,171	100.0%

表3 職区分別

	回答者	
	人数	割合
1.管理者・技術者	723	61.7%
2.職長	65	5.6%
3.作業員	220	18.8%
4.その他	109	9.3%
5.不明	54	4.6%
合計	1,171	100.0%

表4 所属業者区分別

	回答者	
	人数	割合
1.主に元請業者	661	56.4%
2.主に1次請負業者	309	26.4%
3.主に2次以下の請負業者	34	2.9%
4.一人親方	35	3.0%
5.不明	132	11.3%
合計	1,171	100.0%

9

高木 まず第2章ですが、労働安全行政施策に基づいて事業者が講ずべき措置の基本事項として「安全衛生教育の推進」が考えられます。特に小規模です。その中で、管工事業者の安全教育の実態調査を行いました。これは全国管工事業協同組合連合会会員対象のアンケート調査です。2014年に実施しましたが回答が1171人から寄せられました。下の表2には所属業者の規模別の回答者数を記載しましたが、30人以下の小規模の事業者が多いです。表3が職区分別で管理者・技術者の割合が最も多くなっています。表4は所属業者区分別ですが、主に元請業者が661人で、それ以外は主に1次請負業者、主に2次以下の請負業者、一人親方を捕捉しています。このような構成で分析を行っています。

(アンケート結果例) ◆安全教育の受講頻度

- 「主に2次以下」「一人親方」は、月1回以上が少ない。
- 「一人親方」は、「ほとんどない」が多い。
- 「従業員5人以下」は、月1回以上が少ない。



図7 所属業者区分別



図8 所属業者従業員規模別 (51～300人省略)

高木 アンケート結果の例として、安全教育の受講頻度がありますが、図7をご覧ください。実際に安全教育をどのくらいの頻度で受けていますかという質問に対する回答です。元請と1次、2次で差があり、さらには一人親方になりますと、「ほとんどない」が25.7%になります。このような実態が明らかになりました。これを従業員規模別でみるとどうなるかといえば、図8をご覧ください。ご想像の通りかと思いますが、月1回以上の頻度で受けているという回答は、301人以上と比べると5人以下が極めて低い結果になっています。

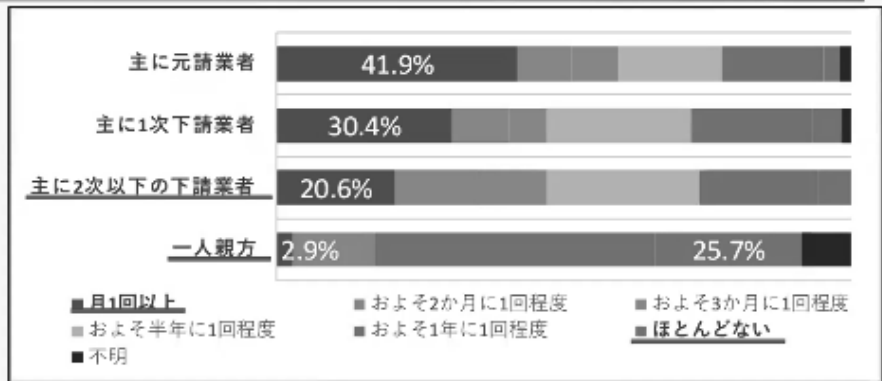

## 東京都水道局受注業者対象アンケート調査

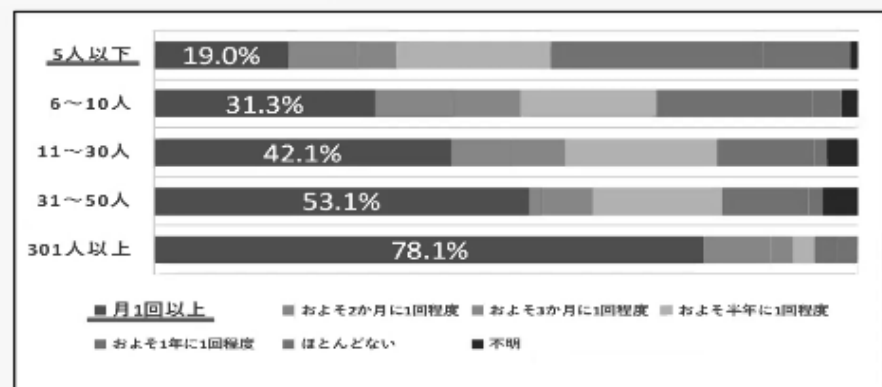
調査対象：元請の現場管理者・技術者

- ・建設事務所開催講習会受講者（計2回）

回答者数：78（所属企業従業員数51人以上で85.9%）

- ・支所開催講習会受講者（計2回）

回答者数：80（所属企業従業員数50人未満で75.0%）

調査時期：2015年11月～2016年2月

### ◆所属企業の安全管理水準の実態

- ・支所分は、建設事務所分と比べ作業手順書の作成、協力会社への送り出し教育、安全パトロール、安全大会の実施の実施割合は低かった。



図9 作業手順書の作成



図10 協力会社への送り出し教育

11

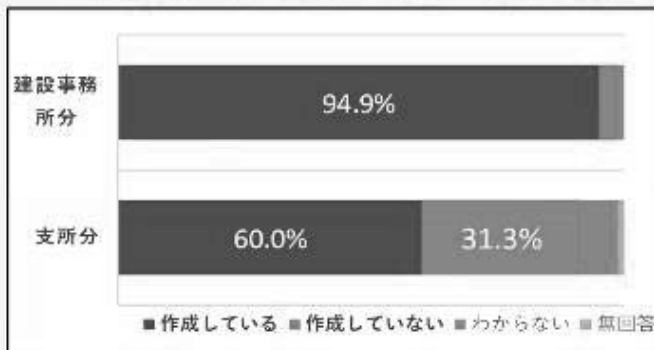
高木 次に、東京水道局受注業者を対象としたアンケートです。これは、建設事務所開催の講習会（・・・通信障害・・・）建設事務所の規模は大小様々ですが、規模に関わらず建設事務所と理解してください。その中で受講者は従業員数51人以上で85.9%、支所は50人未満で75%です。これはどのような質問かという、「あなたの会社の安全管理水準はどうか」というものです。左側の図9ですが、作業手順書を作成しているか否かを問われると、建設事務所はほとんどが作成しているのに対し、支所は6割程度の状況です。図10では、元請として協力会社に対して現場に来る前に一定の教育を実施しているか否かの質問ですが、建設事務所は9割近く実施していますが、支所になると4割にも満たないといったように、大きな差があります。この2つの図を見ると、支所の安全管理水準の低さがよく分かります。

## ◆ドラグショベル災害撲滅への自信

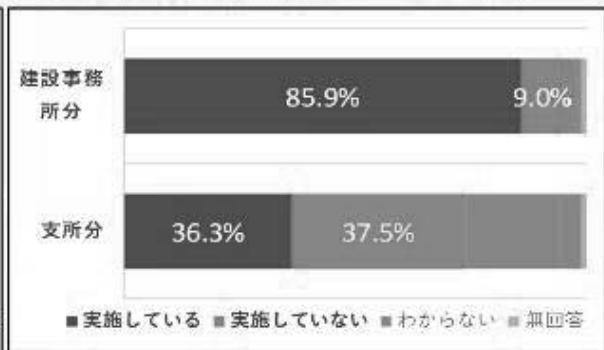

- ・「強い自信がある」「ある程度ある」の合計は、支所分は、建設事務所分より高かった。
- ・支所分は、建設事務所分と比べ、安全管理水準が低いものの、災害撲滅への自信は高かった。  
→この自信は過信につながる



図11 ドラグショベル災害撲滅への自信

## (第2章まとめ) 中小建設業の安全教育推進上の課題

- 課題1：従業員5人以下の業者及び2次以下の下請業者に所属する者、一人親方は、安全教育の受講頻度が少ない
- 課題2：小規模建設業者の多くは、労働災害事例を十分に活用できていない
- 課題3：小規模建設業者の多くは、社内講師、教育に活用できる機器が乏しい
- 課題4：中小元請業者の現場責任者の多くは、労働災害は起こらないと過信傾向にある

12

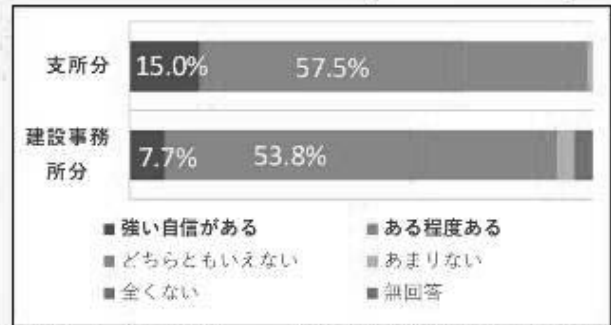
高木 しかし、次のドラグショベル災害撲滅への自信、ドラグショベルとは右側の写真のような（・・・通信障害・・・）災害撲滅の自信については、支所の割合の方が高いという結果が出ています。心理学の話で、一定の教育をけないと過信に満ちた行動をとるようですが、それが当てはまるような話で、このように自信というより過信につながるのではないかと、そんな実態が明らかになりました。最後に第2章のまとめとして、4つの課題を示しています。



## 第3章 労働安全行政における中小企業の指導に係る実態と課題

- 労働安全行政における小規模建設工事に対する指導は、中小建設業の特性を踏まえた効果的・効率的な指導、事業者の自主的な安全活動を促進させるための指導、安全な施工方法の採用等の技術的な指導などが求められる。
- 労働安全行政対象のアンケート調査等を基に、中小建設業の指導の実態調査を行った。

### 労働基準監督署による監督指導

- 「監督業務運営要領」等に基づく計画的な個別指導、集団指導であるため、自主的な取り組みは制限
- 技官の採用が制限され、代わりに法律を専門とする監督官が増加

13

高木 次に労働安全行政における中小企業の指導に係る実態と課題です。労働安全行政における小規模建設工事に対しては、中小建設業の特性を踏まえた効果的・効率的な指導、事業者の自主的な安全活動を促進させるための指導、技術的な指導が求められています。中でも、技術的な指導が重要かと思われます。「労働基準監督署による監督指導」というのは、「監督業務運営要領」（・・・通信障害・・・）計画的な個別指導、集団指導を行ってウロウロして、その管轄を・・・というよりも、計画的に動いていく…という逆には言いえ自主的な取り組みは制限されているということです。また、技官の採用が制限され、法律を専門とする監督官が増加しています。これも、労働災害防止計画をみていると、昭和47年に労働安全衛生法が施行された直後の災防計画には、法令遵守のために技官を大量に、ということが書かれています。しかし行財政改革が始まって今日まで、技官ではなく法律を専門とする監督官がといったように、この20～30年でも大きく変わってきています。

## 労働基準監督署：小規模建設工事の指導上の課題

- ・小規模建設工事のほとんどは、適用事業報告や特定元方事業報告、足場等設置届等、労働基準監督署への届出の必要がない。このため、工事の存在自体の把握が難しく、個別指導の対象にならない。

## 労働局アンケート調査

### ① 調査方法

都道府県労働局安全主務課長を対象とした調査票郵送方式

### ② 調査時期

2014年2月～2014年3月

### ③ 調査項目

全産業対象に、中小企業に効果があった指導、中小企業への指導上の課題、中小企業の指導に必要なもの等

### ④ 回収状況

回収数43、回収率91.5%

14

## ◆中小企業への指導に必要なもの（記述回答）

- ・建設業の特徴は、墜落災害、重機関連災害等、特定の事故の型、起因物等を対象とした労働災害の詳細分析結果が必要との回答が最も多かった。
- 建設業は、多種多様な工事種類、専門工事業種、作業内容等があることから、特定の作業等を対象とした労働災害の詳細分析を行い、それに基づく、きめ細やかな指導が必要（現状の公表データでは不十分）

## （第3章まとめ）労働安全行政による指導の課題

課題4：小規模建設工事の実態が把握できない

課題5：技術的指導力が低下している

課題6：労働災害の詳細分析結果が十分に提供されていない

課題7：施工業者単位の体制整備の指導を行うことは難しい

労働安全行政は、中小建設業に対し工事現場単位ではなく施工業者単位での指導が定められているが、第2章の管工事業対象の安全教育の実態調査からは、特有の課題が見受けられた従業員5人以下の業者、2次以下の下請業者等の安全管理水準が低いことから、施工業者単位での安全管理体制の整備を指導することは難しい。

15

高木 監督署の小規模建設工事の指導上の課題ですが、ひと言でいうとどこでどのような工事が行われるのか分からないということです。これは、監督署への届出というものは、先ほども言いました大がかりなものや、危険有害な作業などで設置届等が必要となりますが、そういうものが必要のない（・・・通信障害・・・）中小の建設業者が見つけれないということに直結するのではないかと思います。次に、労働局のアンケート調査を実施しました。各労働局にて2014年に実施しましたが、中小企業の指導に必要なものとして、現状のものよりもさらにもっときめ細やかな災害分析結果が欲しい、現状の公表データでは不十分などといった声がきこえてきました。ということで、第3章では4つの課題が出てきましたが、このうちの「課題7：施工業者単位の体制整備の指導を行うことは難しい」について、先ほども言いましたように、小規模工事は安衛法の特徴である事業場単位の指導ではなく、施工業者単位の指導にせよと通達で定められています。しかし、施工業者単位というのは、中小の実態を調べたところ、管工事業であれば、たとえば施工業者単位となると2次の下請や従業員5人以下であったり、そうなるとその会社への指導は事業場単位と同じような指導の難しさが出てくるわけです。（・・・通信障害・・・）

## 第4章 欧米諸国と比較したわが国の労働安全行政における中小企業施策の課題の抽出

- わが国の労働安全行政における中小企業施策の課題、有効な公的支援・指導策を見出すため、欧米諸国の関連施策の事例調査等を行った。

### 事例調査の方法（Web文献調査）

- ヨーロッパは、欧州労働安全衛生機関報告書「中小企業の労働安全衛生の改善—効果的支援の実例—」における比較的GDPの高い国の計11事例を対象とした。
- 米国は、OSHA（労働安全衛生庁）、NIOSH（国立労働安全衛生研究所）の中小企業支援事例（HP掲載：計6事例）を対象とした。

### 労働安全行政経験者ヒアリング調査

- 欧米の中小企業支援事例のわが国への適用を検討するため、労働安全行政経験者1名を対象に、事前に事例調査の内容を説明した上で、複数の労働安全行政経験者の意見集約を経て回答を得た。

16

高木 次に第4章は、欧米諸国と比較したわが国の労働安全行政における中小企業施策の課題の抽出です。これは事例調査をWebや文献等で実施しました。ヨーロッパでは、欧州労働安全衛生機関報告書「中小企業の労働安全衛生の改善—効果的支援の実例—」の中にいくつか事例があったのですが、日本が参考とすべき比較的GDPの高い国の計11事例を対象としています。一方アメリカは、OSHA、NIOSHの中小企業支援事例6事例を対象としました。そして、欧米の調査を行ったうえで、それをそのまま日本に持ち込めるわけではないので、日本に適用する際には労働安全行政経験者にヒアリング調査をし、事例ひとつひとつを検討して仕分けをしながらまとめていったものです。



## 欧州の中小企業の労働災害発生について

- EU全体では、中小企業（従業員数250人未満）は全企業の約99%を占め、労働者の約66%が中小企業に雇用されている。
- Eurostat（欧州委員会統計担当部門）の調査によると、致命的な労働災害は、零細企業（同10人未満）で最も多く発生し、3日以上 の休業を伴う事故は、小規模企業（同10～49人）が最も多い。
- 業種別では、建設業、農業、製造業、電気・ガス・水道業、卸売業、修理業、ホテル業、飲食業、運輸・通信業等で労働災害が多発。
- このうち、建設業、卸売業、修理業、ホテル業、飲食業のケータリ ング業、運輸業の労働災害は中小企業が99.9%を占める。
- これら業種の課題：a. 労働災害リスクや関係法規に関する知識不足、b. 労働災害防止活動推進に必要な時間や資料の不足、c. 担当 部門がない／行政との接点がない、d. 相談体制の未整備、e. 労働 災害防止意識の欠如、f. 労働災害防止活動が社長任せ 等
- EUは「EU Health and Safety at Work Strategy（EU労働安全 衛生戦略、対象年度2007年～2012年）」を策定。労働災害25% 削減の目標設定。達成には中小企業、下請企業対策が重要。

17

高木 欧州の中小企業の労働災害発生についてですが、中小企業（従業員数250人未満）は全企業の約99%を占め、労働者の約66%が中小企業に雇用されています。そしてEurostatの調査によると、致命的な労働災害（死亡災害等）は、零細企業（10人未満）で最も多く発生していました。衝撃的だったのは、建設業、卸売業、修理業等々の労働災害は中小企業が99%を占めるということですが、日本はこれほど多くはありません。しかし日本でも中小がほとんどを占めます。これら業種の課題として、労働災害リスクや関係法規に関する知識不足、あるいは行政との接点がないといった点が挙げられます。またEUは2007年から2012年の間に労働安全衛生戦略を出して、労働災害25%削減の目標設定をしました。その達成には中小企業、下請企業対策が重要であるという一文がありますが、これを第13次災防計画と比較すると、ヨーロッパの方が中小企業を重視しているといえます。

## （比較）第13次労働災害防止計画 中小規模事業場の対策

### 4 重点事項ごとの具体的取組

#### （6）企業・業界単位での安全衛生の取組の強化

#### ク. 中小規模事業場への支援

- 中小規模事業場における安全衛生管理体制を整備するとともに、4S（整理・整頓・清掃・清潔）、「危険の見える化」、リスクアセスメント等の安全衛生活動を活性化させるため、安全管理士や衛生管理士による職場改善指導等の労働災害防止団体を通じた支援の充実を図る。
- 構造規格等の改正時には、経過措置により、既存の機械等への最新基準の適用が猶予されることが多いが、これらの更新を促進するための支援措置等について検討する。



図3 建災防会員・非会員別  
死亡災害発生割合（H25）

18

高木 これは、第13次災防計画との比較になりますが（・・・通信障害・・・）第13次防の具体的取組みが2つの「・」で示されています。一つ目には4Sや「危険の見える化」などいろいろ書かれていますが、労働災害防止団体を通じた支援の充実を図るという取組みです。先ほど冒頭でお話しし、また図3のグラフにもあるように、災防団体の非会員の災害の方がはるかに多い状況です。こういう実態を少しでも改善していかないと、労働災害の防止は難しいのではないかとということが、ここで課題として挙げられます。

## 調査結果の考察

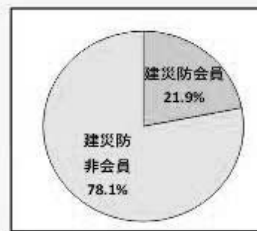
ヒアリング調査に基づき、今後のわが国の労働安全行政施策に参考となる事例を抽出し、それらを基に、労働安全行政施策の新たな視点を見出した。

- フィンランド「経営リスク管理ツール」、オランダ「専門業種別規約」  
→経営リスク全般（人事、資産、契約等）を対象とした総合的な支援
- 米国「OSHAと製造業団体等との連携」、フィンランド「経営リスク管理ツール」等→中小企業の経営支援を所管する行政との連携
- イギリス「良き隣人プロジェクト」→大企業保有のノウハウを中小企業に習得させる仕組みづくり
- イギリス「新ガイドライン“労働安全衛生を簡単に”」→中小企業における労働安全衛生法規の理解不足の解消
- 米国「現場コンサルテーションプログラム」、「有害性評価プログラム（HHE）」等→企業、団体等からの個別依頼に応じた行政支援

19



高木 欧米の調査結果の考察ですが、ヒアリング調査に基づき、今後のわが国の労働安全行政施策に参考となる事例を抽出し、それらを基に、労働安全行政施策の新たな視点を見出したものと位置付けました。まず、フィンランドやオランダの事例で、経営リスク全般を対象とした総合的な支援をする。これは、安全だけの指導ではなく、人事や資産の問題についても関連し、要するに安全というものを経営リスクのひとつとして位置づけ、経営リスク全般を対象に総合支援をするというものです。

## b) 中小企業の経営支援を所管する行政との連携

### 【事例】OSHAと製造業技術センターとの連携（米国）

#### ①実施主体

- ・ OSHA、MANTEC（The Manufacturing Technology Center、製造業技術センター）の連携

#### ②概要（事業開始年：2010年）

- ・ OSHAは、ペンシルバニア州の製造業発展を目的に設立されたNPO法人MANTEC（州地域振興経済開発省とMEP（製造業者普及パートナーシップ）が支援）と連携し、MANTEC会員である中小企業の労働安全衛生問題の解決に向け、教育研修プログラムの作成、中小企業向け経営説明会への講師派遣、MANTEC労働安全衛生カリキュラムの水準向上等を行った。一方、MANTECは、製造業向け技術誌でOSHA関連情報を提供し、OSHA各種プログラムに対し中小企業の参入を促した。

20

高木 また、中小企業の経営支援を所管する行政との連携を図る。日本では、少し前に鉄鋼連盟と中災防が連携したという例がありますが、向こうでは中小企業が連携しています。これがOSHAの例のひとつですが、OSHAと製造業技術センターとの連携を行います。OSHAはアメリカの労働安全衛生庁です。そしてNPO法人と連携して、その会員・・・彼らは安全衛生を目的として加入しているわけではなく、製造業の業界団体で主として製品開発など自社の売上向上に参考となる情報を集めるために加入しているわけですが、そういう団体と連携してその会員に（・・・通信障害・・・）安全の協力をしていく。イギリスでは、大企業保有のノウハウを中小企業に習得させる仕組みづくり、あるいは「新ガイドライン“労働安全衛生を簡単に”」という中小企業における労働安全衛生法規の理解不足の解消につながるような政策をうつ。何かともかく難しい法規をもっと簡単にみせ、それで理解を促進させるような施策とか、あるいはアメリカの「現場コンサルテーションプログラム」、「有害性評価プログラム」のように、今まではトップダウンであったものが、現在は企業や団体からの個別依頼に応じた行政支援をしていくものです。

## e) 企業等の依頼に応じた行政支援

### 【事例】現場コンサルテーションプログラム（米国）

#### ①実施主体

- OSHA

#### ②概要

- 現場コンサルテーションプログラム（無料）の活用好事例として紹介されたものを以下に示す。
- コンクリート製品製造会社の事例（2005年開始）

この会社は従業員約20人で、コンクリート造協会入会を機に、ニューヨーク州労働局に本プログラムを申請し、派遣された州政府コンサルタントによる事業場視察の結果、狭隘空間、記録保存、危険情報連絡方法等で問題点を指摘された。同社はそれらを解決するため包括的安全プログラム、研修プログラム等を作成し、従業員の安全確保と作業性向上を図り、OSHA安全衛生達成認定プログラム（SHARP）に承認された。

21

## g) 中小企業への新たな規制による労働安全推進

### 【事例】中小企業労働衛生支援（デンマーク）

#### ①実施主体

- OHS（Occupational Health Service Centre、労働衛生サービスセンター）

#### ②概要（事業実施期間：1996年～2000年）

- 北シェラン島にあるOHSは、デンマーク企業の労働衛生促進の中心的役割を担う公的機関である。1998年施行の職場環境法では、特定セクター（工業等）に属する企業はOHSへの入会が義務づけられた。
- 本事業は、OHS会員の中小企業のうち、製造業、建設業、サービス業（ホテル、レストラン等）を主対象に、通常業務に導入できる支援策の開発を目的に、中小企業向けコンサルティングサービス、作業環境評価、就業後セミナー、中小企業間交流セミナー等を行った。運営資金は全国労働環境委員会が拠出した。
- 本事業は、a. 中小企業経営者へのヒアリング調査、b. 提供サービス開発、c. 視察、d. 中間評価、e. 視察・サービス点検、f. 最終評価、g. 外部評価の順に行われた。OHSは参加企業324社の半数超を視察し、中間評価ではほとんどの中小企業はOHSに満足と回答した。

23

高木 これがどのようなものかという、「現場コンサルテーションプログラム」はOSHAが実施主体ですが、あるコンクリート製品の製造会社の事例で、この会社は業界団体への加入を機に労働局にプログラムを申請して、派遣されたコンサルタントが事業場を視察して改善してゆくといったものです。このように、“個別企業からの依頼に応じた”というのが日本では（・・・通信障害・・・）イギリスの行政による財政支援に基づくものとか、あるいは最後のデンマークの例ですが、中小企業への新たな規制をかけて、安全活動団体への加入を義務づけ、これによって労働安全を推進していくというものです。具

体的には、OHSという労働衛生サービスセンターが実施主体ですが、デンマークで1998年施行の職場環境法では、特定のセクター、とくに有害で危険性の高い業務に属する企業はOHSへの加入が法的に義務づけられます。これによって安全衛生を推進していきます。こうした新たな規制も参考になると思います。

- イギリス「慈善団体による中小企業安全支援」、フランス「安全コーディネーター派遣」→行政による財政支援に基づく慈善団体支援、健康保険関連基金による財政支援に基づく中小企業等組合等支援
- デンマークの事例「中小企業労働衛生支援」等→中小企業への新たな規制（安全活動団体加入義務づけ）による労働安全推進

### （第4章まとめ）わが国の労働安全行政における 中小企業施策の課題の抽出

#### わが国の労働安全行政施策の新たな視点

- a) 労働災害を含む経営全般リスクの総合的支援
- b) 中小企業の経営支援を所管する行政との連携
- c) 大企業による中小企業支援の仕組みづくり
- d) 労働安全関係法規を理解促進させる取り組み
- e) 企業等の依頼に応じた行政支援
- f) 慈善団体や中小企業等組合への支援
- g) 中小企業への新たな規制による労働安全推進

22

## 第5章 公共工事発注者の労働災害防止に関する取り組みの実態と課題

- 労働安全行政は、発注者に対し、計画段階及び施工時の安全衛生の確保への配慮、労働安全衛生マネジメントシステム等、自主的な安全衛生活動の取り組みを評価する仕組みの導入推進等を要請している。
- 公共工事発注者アンケート調査を実施し、建設工事の労働災害防止推進方策、入札参加業者に対する安全評価等の実態調査を行った。

### 公共工事発注者アンケート調査

- ① 調査方法
  - 全地方自治体1,835、土木工事の発注・施工監理の総括担当者対象の郵送方式
- ② 調査時期 2011年1月～2011年3月
- ③ 調査項目
  - 発注者における労働災害防止に関する取り組みの実態と課題
- ④ 回収状況
  - 回答数713、回収率38.0%

表5 自治体区分別回収数

	回収数
都道府県	25
特別区	15
政令市	10
市(大)人口30万以上	32
市(中)10～30万未満	98
市(小)10万未満	204
町	274
村	55
	713

24



## 公共工事発注者の法的責任

- 労働安全衛生法第3条第3項：注文者の責務「建設工事の注文者等仕事を他人に請け負わせる者は、施工方法、工期等について、安全で衛生的な作業の遂行をそこなうおそれのある条件を附さないように配慮しなければならない」。同第31条の3「注文者は、その請負人に対し、当該仕事に関し、その指示に従って当該請負人の労働者を労働させたならば、この法律又はこれに基づく命令の規定に違反することとなる指示をしてはならない」
- 刑法第211条：業務上過失に関し「業務上必要な注意を怠り、よって人を死傷させた者は、五年以下の懲役若しくは禁錮又は五十万円以下の罰金に処する。重大な過失により人を死傷させた者も、同様とする」
- 民法第716条：注文者の責務として、「発注者が請負人の仕事の施工に関して行った注文または指示に過失があった場合にその損害を賠償する責任を負う。それ以外の場合は発注者にその責任がない。
- 国土交通省工事請負契約書第26条：臨機の措置として「監督職員は、災害防止その他工事の施工上特に必要があると認めるときは、請負者に対して臨機の措置をとることを請求することができる」→請求できる一方、それを怠った時に責任が発生する可能性あり。

25

高木 次が第5章で、公共工事発注者の労働災害防止に関する取り組みの実態と課題です。先ほども言いましたように、労働安全行政は発注者に対し、連携して災害を減らしていこうということですが、これは昭和30年代に（・・・通信障害・・・）長年続いているものですが、発注者に対して計画段階および施工時の安全衛生の確保への配慮、あるいはマネジメントシステムの導入等自主的な安全衛生活動の取り組みを評価する仕組みです。こういったことの導入推進を要請しています。その実態を調べるために、公共工事発注者を対象にアンケートを実施しました。全地方自治体で2011年に実施しましたが、当時は1835の自治体がありましたところ、713の自治体から回答を得ました。ここで発注者の法的責任を整理すると、安衛法第3条第3項の注文者、第31条の3もそうです。ほかに刑法第211条、民法第716条、それとともに国交省が定めている請負契約約款第26条に「臨機の措置」に関する規定があります。いわく、「監督職員は、災害防止その他工事の施工上特に必要があると認めるときは、請負者に対して臨機の措置を採ることを請求することができる」とされています。昔、松戸川の河川で発注者が出すべき退避命令が遅れたことによって何人も亡くなったことが、ここでいう臨機の措置が適切に講じられていないことが原因だったとして、国家賠償がらみの紛争に至りましたが、その際の根拠規定として援用されています。

(アンケート結果) ◆規模が小さな地方自治体について

- 村、町、市(小:10万未満)は、  
→労働災害防止の担い手に、発注者を含む割合が低い(図15)  
→安全パトロール不参加割合が高い(図16)。  
→災害発生に伴う減点措置の実施割合が低い(図17)。



図16 安全パトロール参加状況 (複数回答あり)



図15 労働災害防止の担い手の考え方

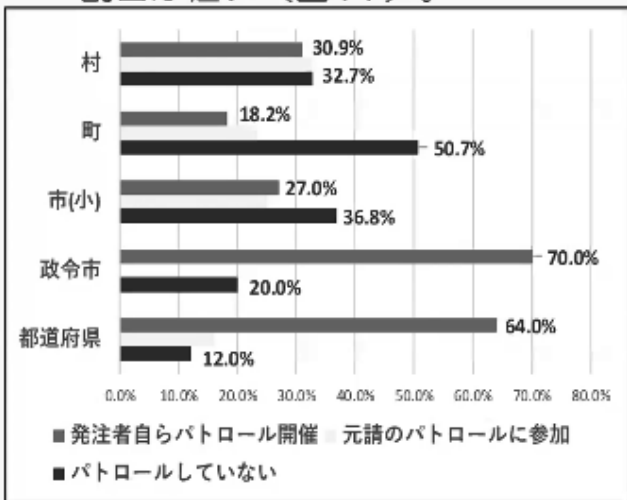

図17 工事成績評定「災害に伴う減点措置」

注) 市(中)、市(大)、特別区のデータ省略<sup>26</sup>

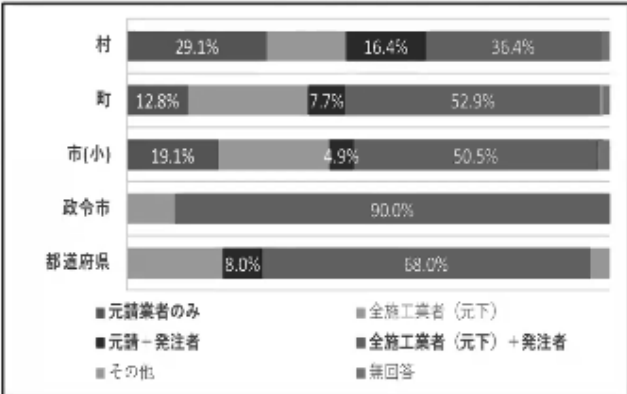
高木 このアンケート調査ですが、発注者と行政が連携して安全を推進していこうといっても、やはり規模の小さな事業者では内部にエンジニアもいません。たとえば図16「安全パトロール参加状況」ですが、政令市や都道府県では発注者自らパトロールを実施している割合が多い一方で(※赤い棒グラフ)、村や町ではその割合が低くなっています。また、図17「工事成績評定」ですが、これは事故を起こしたときの減点措置です。政令市、都道府県、国交省問わず一見どこでもやっているような制度かと思いましたが、村や町になるとさほど実施されていません。

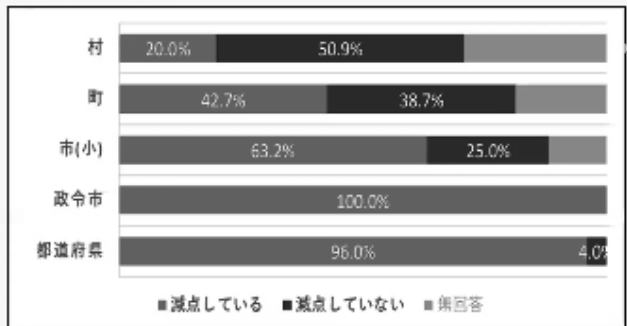

◆労働災害データ保有・分析 ◆入札参加業者の安全面の評価

・全体的に取り組みが低調だったのは、労働災害データの保有・分析。「データをもっていない」が70%を超え、「分析している」は、都道府県40%、政令市20%に留まった（下図）。

・入札参加資格審査等では、各種安全教育、安全表彰、マネジメントシステム認証取得、防災団体加入等を加点しているところは少なかった（下図）。



図18 労働災害データの保有・分析状況



図19 入札参加資格審査における安全評価

高木 これは（・・・通信障害・・・）後で発注者に安全対策の役割を求めたいのですが、実際にアンケートを取ると、自分のところで発生した労働災害データを持っているかいないかが決め手となることは、図18が示しています。赤い棒グラフが「データがない」です。ご覧の通り、村から特別区までほとんどデータを持っていません。たとえば、世田谷区で発生した労働災害について、世田谷区の担当者が知らないという状況です。また、青い棒グラフは「分析している」割合です。災害が発生したらそれを分析して、自分たちの事故防止に活かすわけですが、それを実施しているのは都道府県でさえ4割、政令市でも2割程度です。図19は「入札参加資格審査における安全評価」ですが、これは厚生労働省が事業者の自主的な安全活動を促進させるために、事故を起こしたことで減点するのではなく、安全衛生に一生懸命頑張っている事業者を加点方式で評価しようということで、ここに書いてあるように防災団体加入や（・・・通信障害・・・）こういう促進策を少し前に講じたのですが、実際にはこの当時でさえ加点対象となる事業者が少ない実態も明らかになりました。これは、厚生労働省として経営者の安全意識を高めるツールとして適したものなのですが、一方で労働災害防止のマネジメントシステムを取得しているところがほんの少しに過ぎないので、これを制度として盛り込めない発注者としての事情もあります。こういった入札業者の安全面での評価があまり行われていないということが明らかになりました。

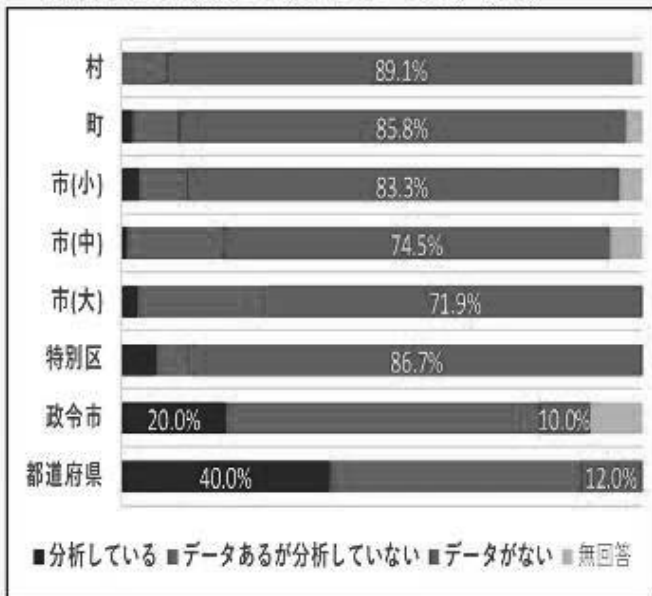
## 労働災害発生件数（休業4日以上死傷災害、H20年度）

- 都道府県は、5人以上で76%
- 一方、発生0人は、市(大)が75%、市(中)80.6%、市(小)89.2%、町93.4%、村98.2%を占めた。

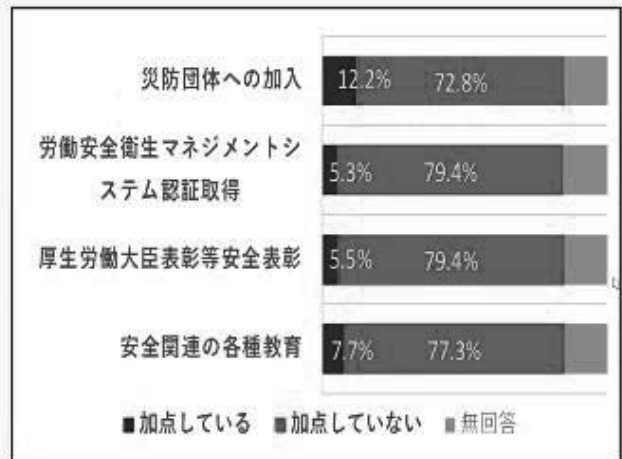
### ◆発注者の課題（記述回答）

- 発注者は、請負業者への指導の必要性を認めつつも、それができず、職員減少による工事担当者の不足、職員安全教育の不足等を課題にあげた。

### （第5章まとめ）公共工事発注者による支援・指導の課題

- 課題9：規模の小さな地方自治体は総じて労働災害防止に関する取り組みが低調である
- 課題10：労働災害データの活用が進んでいない
- 課題11：請負業者への指導力が不足している
- 課題12：入札において事業者の自主的な安全活動を評価する仕組みの導入が進んでいない

28

高木 そういったところで、発注者の課題としては、課題9から課題12が挙げられます。すなわち、規模の小さな地方自治体では労災防止に関する取り組みが低調である、労働災害データの活用が進んでいない、請負業者への指導力が不足している、そして最後に入札時の問題です。

## 第6章 専門工事業団体における安全活動支援の実態と課題

- 労働安全行政は、専門工事業団体に対し、中小専門工事業の安全管理水準向上のための支援を要請している。
- 専門工事業者の専門工事業団体への加盟割合を把握するとともに、専門工事業団体を対象にアンケート調査を実施し、各団体の安全活動支援の実態調査を行った。

### 建設産業団体に所属する建設業者の割合

- 舗装工事業、大工工事業、鉄骨・鉄筋工事業、電気通信・信号装置工事業、機械器具設置工事業など、加盟割合が低い業種が少なくない。

建設業区分 (標準産業分類に基づく)	事業所数	建設産業団体に所属する建設業者数*	構成比
	A	B	B/A*100
舗装工事業	7,946	266	3.3%
大工工事業	30,672	496	1.6%
とび・土工・コンクリート工事業	17,249	11,925	69.1%
鉄骨・鉄筋工事業	12,295	1,063	8.6%
石工・れんが等工事業	8,613	1,939	22.5%
左官工事業	19,657	9,103	46.3%
板金・金物工事業	20,009	11,640	58.2%
塗装工事業	24,968	3,806	15.2%
床・内装工事業	26,558	7,364	27.7%
電気工事業	55,774	44,858	80.4%
電気通信・信号装置工事業	9,633	936	9.7%
管工事業(さく井工事業を除く)	58,219	35,748	61.4%
機械器具設置工事業	6,861	276	4.0%

\*建設産業団体要覧に記載されている建設産業団体に正会員として加盟している建設業者数。ただし、会員が事業協同組合等団体の場合、その団体の構成員の建設業者数。複数の建設産業団体に加盟している建設業者あり。一部の建設産業団体は、大手企業、メーカーも正会員に含まれるが少数である。

資料：事業所数は総務省「平成18年事業所・企業統計調査」、建設産業団体に所属する建設業者数は一般財団法人建設業振興基金「建設産業団体要覧(平成18年度版)」調べ。ただ、そこに正会員数が未記載の場合、当該団体への電話調査による。

表6 建設産業団体に所属する建設業者数

29

高木 次に第6章になりますが、関係業団体としての専門工事業団体の問題です。専門工事業団体と行政は一体となってやっていきたいと思いますとは言っても（・・・通信障害・・・）その団体に加盟している事業者がどれくらいあるかというのがこの表です。たとえば多いところでは表の上から3つめの「とび・土工・コンクリート工事業」をみると、建設産業団体に所属する建設業者数が11925、事業所数が17249で、70%近くが加盟しています。他方、大工工事業は1.6%、舗装工事業は3.3%にとどまっています。ともかく業界団体と連携していこうと思っても、業界団体未加入が多すぎる業種があるということで、これも大きな課題ではないかと思えます。

## 専門工事業団体アンケート調査

### ① 調査方法

- ・専門工事業団体（70）の事務局長等を対象とした調査票郵送方式

### ② 調査時期

2008年2月～2008年3月

### ③ 回収状況

- ・回収数29、回収率41.4%

### (アンケート結果) ◆安全問題の検討組織

- ・安全問題の検討組織が「特にない」が約4分の1を占めた。
- ・検討組織の活動方針
  - 会員企業の安全活動支援（講習会の実施、資料提供等）
  - 会員企業の安全管理水準向上のための人材育成
  - 安全問題に係る調査研究の実施



図20 安全問題の検討組織の有無

30

高木 実際に専門工事業団体を対象にアンケートを実施しましたが、図20は安全問題に関する検討組織を持っているかという質問に対する回答です。ご覧のように、「特にない」という回答が約4分の1ほどありました。「4分の1 “も” ある」という見方もできます。しかし、他の調査で自動車部品製造業や化学工業などと比較すると、（・・・通信障害・・・）そういうこともまた別の問題としてあるわけです。建設業でいうと、特にないという回答が24.1%です。この調査を行ったときは、ちょうどリスクアセスメントを導入した平成18年の2年後だったのですが、2年経っても3分の1くらい（31%）は会員の支援を何もやっていないというものでした。そのような課題もあります。団体による支援の課題は、何はともあれ小さな会社によって構成される団体は、お金がないということです。何かやりたくても財政的な問題にぶつかるということを常に挙げています。言い訳のような面もあるかもしれないにせよ、実態としてはそうです。

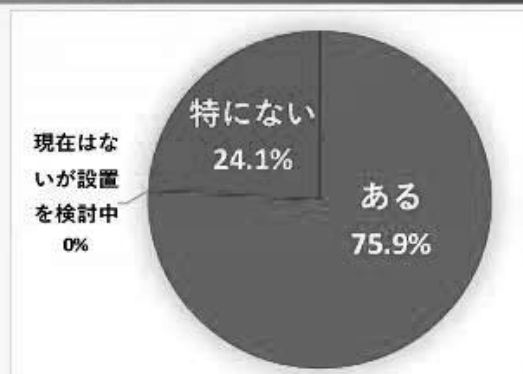

## ◆リスクアセスメント導入支援

- リスクアセスメントが努力義務化された約2年後の支援状況をみると、何もしていない団体が約3割も占めた。



図21 リスクアセスメント導入支援

## ◆中小専門工事業の自主的な安全活動の促進方策（記述回答）

- 様々な促進方策が示されたが、専門工事業団体の多くは経営規模が小さな中小専門工事業者で構成されており、実施には財政面の課題があげられる。

### （第6章まとめ） 専門工事業団体による支援の課題

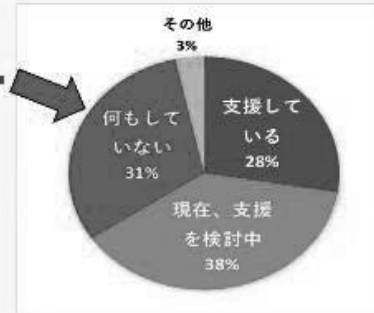
課題13：専門工事業団体には、加盟率の低い業種や安全活動支援を行っていない団体がある

課題14：専門工事業団体には財政的支援が求められる

31

高木 第6章の課題としては、加盟率の低い業種や安全活動支援を行っていない団体がある、そして専門工事業団体には財政的支援が求められる。

以上のおおりに、実態調査から14におよぶ課題を見つけました。それを課題相互の関連として示したのが図22です。

## 課題相互の関連（図22）

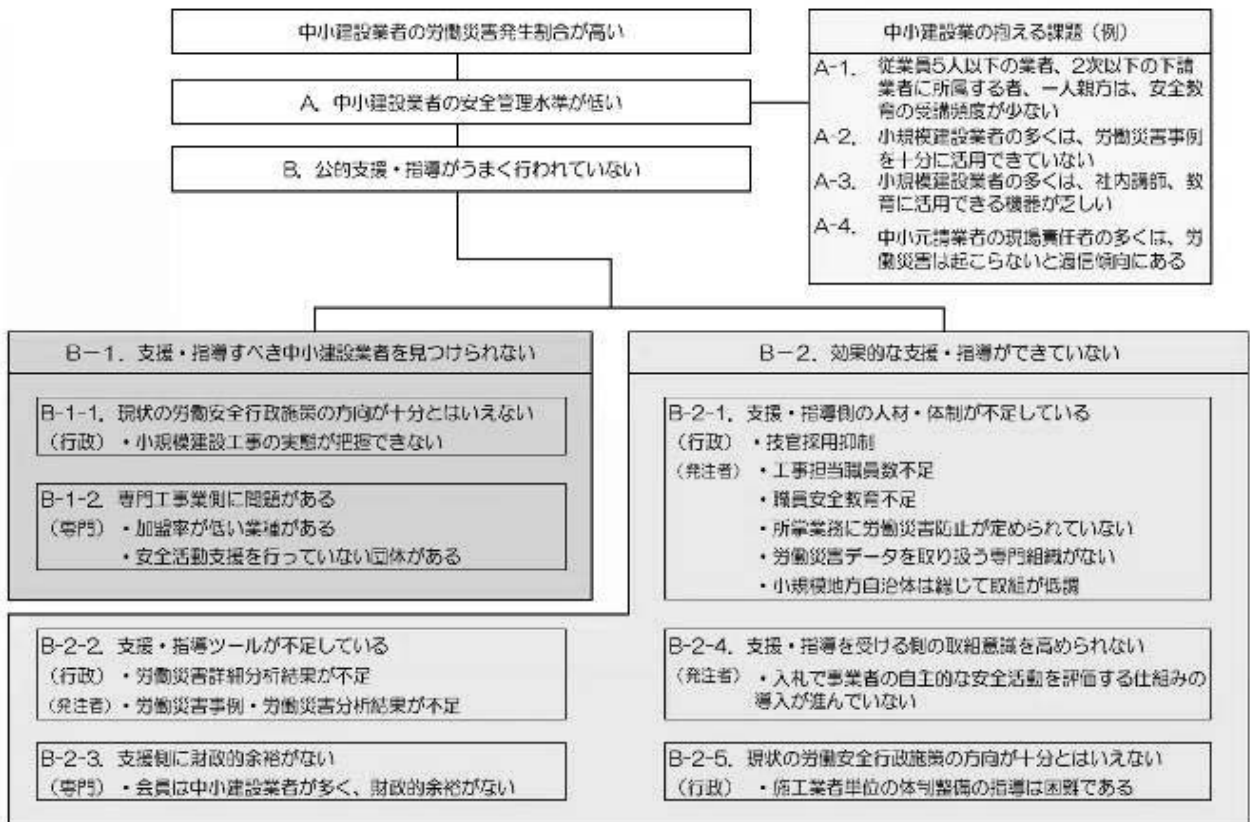

32

高木 これは、一番上が最初に（・・・通信障害・・・）労働災害発生割合が高いという実態調査からA-1からA-4までの課題が出てきました。ではその原因は公的支援・指導が上手く行われていないというのは仮説です。紫色のB-1で「支援・指導すべき中小建設業者を見つけれない」、具体的には小規模工事の実態が把握できていないという現状があったり、あるいは専門工事業体に加盟していない業者がある、また安全活動を行っていない団体がある、といった課題のほか、右側の水色の部分ですが、B-2「効果的な支援・指導ができていない」要因として、支援・指導側の人材・体制が不足している、支援・指導ツールが不足している、財政面の問題がある、また支援・指導を受ける側の取組意識を高める方策、先ほどの入札の際の制度のようなものがなかなかできずに高まらない、そして現状の労働安全行政施策の方向が十分とはいえない、どちらかというところだと施工業者単位で（・・・通信障害・・・）出すのが難しいから、B-2-5までの課題を先ほどの欧米調査結果とリンクをつけたのが図23です。



## 課題解決の参考となる欧米調査結果（図23）

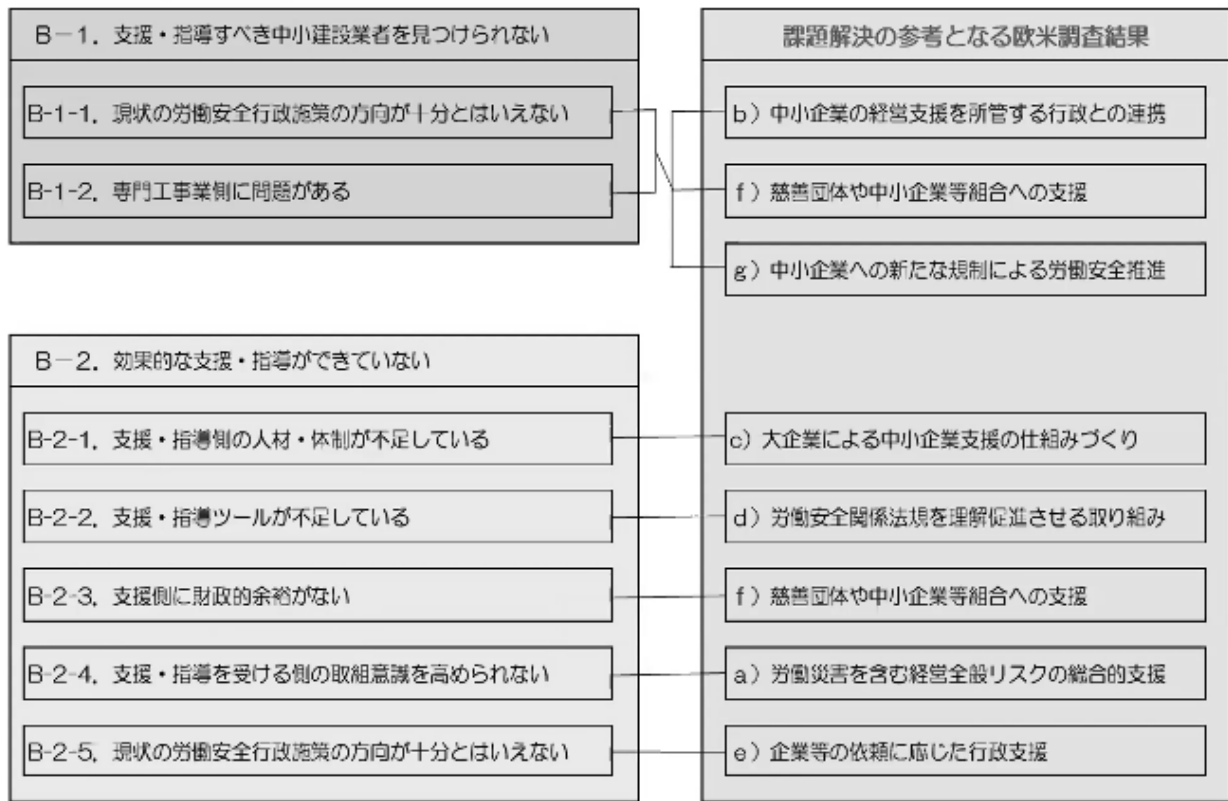

33

高木 B-1「支援・指導すべき中小建設業者を見つけられない」という課題に対し、右側b)の中小企業の経営支援を所管する行政と連携することによって、たとえば商工会議所と連携して（とはいえ商工会議所と連携しようとしてもなかなか上手くいっていないという実態をよく耳にしますが）、これまで安全とは無縁だった会員を見つけてそこを指導していく、あるいはg)中小企業への新たな規制による労働安全推進、デンマークの事例のように入会を義務付けしてそこで指導していくとか、そのような施策が挙げられます。B-2「効果的な支援・指導ができていない」という課題に対しては、先ほどの欧米の事例を上手く活用しながら新たな施策として考えられるのではないかと（・・・通信障害・・・）

## 中小企業に対する労働安全行政施策の方向（案）

- （建設業）中小企業でも安全な事業場の提供  
→発注者、設計者の安全責任（リスクの小さな事業場の提供：法整備）
- 中小企業に適した自主的な安全活動推進  
→例：簡易版リスクアセスメント（法的義務化）
- 一人親方対策（請負契約者の安全確保：現在欧米調査中）
- 労働安全行政が指導すべき中小企業を見つける施策  
→例：経産省と労働安全行政との連携による総合的支援
- 労働安全行政の中小企業への指導の充実  
→中小企業対策をより重点課題に位置づける  
→技術的指導の拡充  
→指導メニューの拡充（例：個別依頼）
- その他

34

高木 中小企業でも安全な事業場を提供してゆく、これは大きな問題で、安全管理水準を彼らが自ら高めなくても、事業場リスクが少なければそれでいいわけです。そうすると、発注者、設計者の安全責任・・・これは法律でも定められていて、当方の研究でも詳細に調査していますが、このようにしてリスクの小さな事業場を提供していくための法整備が必要かと思われま。次に、中小企業に適した自主的な安全活動推進です。やはり、現行法所定のリスクアセスメントは実施が難しいです。労働安全衛生総合研究所のHP (<https://www.jniosh.johas.go.jp/>) をご覧いただくと、化学物質などいろいろな簡易的リスクアセスメントについて掲載されていますが、簡単な方法を提示したうえでイギリスのように罰則付きで法令上義務化して推進させる方途もあるのではないかと思います。また、一人親方対策も重要です。今回お話が出てこなかったのですが、安全教育を全く受けていない、やはり（・・・通信障害・・・）保護するとともに規制の対象に含めることが大切ではないか、これを適切に行うことによって、現在全国のシルバーサービス人材センターで就労している高齢者（東京だけで8万人います）・・・全員が業務請負契約の主体である一人親方ですが、木から落ちる、駐輪場の自転車の転倒で負傷するなどといった災害に何らの手当もなされていない状況を改善できるのではないかと思います。現在、欧米を調査して一人親方の制度化を検討しているところです。次に、労働安全行政が指導すべき中小企業を見つける施策ですが、これはやはり今まで効果的な支援・指導と言ってはいるのですが、指導の枠の中に入るための施策が求められるということです。あとは、労働安全行政の中小企業への指導の充実ということで（・・・通信障害・・・）発生数も多いし発生率も高く、建設業者のうち99.4%を中小企業が占めるので、もっと重点的に位置づけていけるのではないかと思います。あとは技術的指導の拡充です。現在、監督署の技術系の監督官がどんどん少なくなっていますが、その流れを止められない以上、それを補完するような仕組みを作る、あるいは指導メニューの拡充、すなわち集団指導や個別指導だけではなく、アメリカの現場コ

ンサルテーションのように個別企業からの依頼に応じた対応が求められます。そのようなメニューの拡充が必要になるのではないかと思います。最後の「その他」ですが、日本の特徴としては労働災害防止団団法に基づく労働災害防止団体の存在です。

## 労働災害防止団法

- 国は、労働災害防止を目的として事業者で組織する団体を法律に基づいた認可法人として設立させ、国の施策と相俟ってその団体の会員である事業者等の労働災害防止活動の促進を図る。
- この労働災害防止団体の役割、業務等について定めた法律が、労働災害防止団法（労働安全衛生法の制定時に一部改正）であり、この法律は労働安全衛生法（1972年）より前の1964年に制定され、それに基づいて中央労働災害防止協会及び業種別の労働災害防止団体が設立、運営されている。（労働災害防止団法、労働災害防止団法施行規則）

35

### b. 業種別労働災害防止協会（法第36～50条）

- 労働災害防止規程の設定（厚生労働大臣認可必要）（法第37～41条）
- 会員に対する技術的な事項についての指導、援助
- 指定の業種に関する
  - 機械及び器具についての試験及び検査
  - 労働者の技能に関する講習
  - 調査及び広報
  - 上記に関する付帯的な業務
- 厚生労働大臣から要請があったときには、指定の業種の会員以外に対する上の業務



図3 建災防会員・非会員別死亡災害発生割合（H25）

36

高木 1967年にこの法律が制定されて活動し、今まで大きな（・・・通信障害・・・）会員と非会員の死亡災害の割合を見ると、非会員の割合が高い。この法律の第36条から第50条の中に、業種別労働

災害防止協会の規定があり、基本的には会員でなければいけません。厚労大臣から要請があった場合には、会員以外にも適用されることはありますが、このような災防団体が今までやってきたことを、非会員に対しても培ってきた指導力を提供することによって、労働災害の発生を低減させていくことができるのではないかと思います。

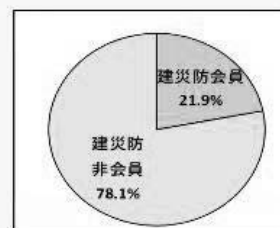
長くなりましたが私の報告は以上です。

三柴 ありがとうございます。ところどころ音声が消えてしまう箇所がありましたが、非常に有意義で価値の高い情報をていねいに語っていただいたので、ご報告の趣旨がよく伝わってきました。では、早速先生方からご意見・ご質問いただきたいところですが、まず私の方からひと言口火を切らせていただきます。高木先生は中小企業の安全対策のために様々な提言を出されましたが、キーワードとして一つは上流へのアプローチです。建設安全に関しても“どこを掘れば温泉が出るか”ということで、発注者であったり、あるいは「場の管理」よりもむしろ業者の中で安全衛生へ影響力を持つ可能性の高いところに規制をかけるなどのアプローチを図った方がいいということも示唆されたと思います。また、災防団体やニアリーイコールの団体に加入していない業者が多いため、そういう業者は強制加入とは言わないまでも、加入率を上げていくという努力も必要です。実際に規制を作っていくとなると、根本的に日本は資本主義の国で契約の自由が重視され、誰とどのような契約を結ぼうが自由とされているから、契約の締結自体を強制するとか、契約の内容について社会規制や技術規制を強めることに対しては抵抗があります。ドイツやフランスのように必要な規制だから作ってしまえ、というようにはいきません。イギリスは安全衛生で痛い目をみた歴史があって、安全衛生に関しては厳しくラジカルな規制をしていますが、実態としては日本と比べてどちらが厳しい規制か判別しがたい面もあります。そういう中で、規制という手法でいくべきか、それ以外の自主管理の取組み促進でいくのか、といった点もよく考えなければいけません。また、中小企業対策では、それこそ現場で苦勞されている安全コンサルタントや社労士の方がよく指摘していますが、事業者にも耳を貸してもらえいくつかの原則というものがあるのが今困っている課題に応える、儲かる、分かり易い、罰則付きの規制に引っ掛かるなど怖い目にあう、親切なアプローチ、またその会社の経営者の思想に適合することです。経営者の数だけ考え方があるので、そこにフィットする必要性も指摘されています。今の高木先生のお話とも大分共通する点があったと思うのですが、いろいろとお話になった中で特に実行可能性、現に実現できるだろうというところも踏まえて優先順位をつけるとすると、高木先生としてはどの辺りから着手すべきとお考えでしょうか。

高木 今の労働安全行政の大きな流れをみると、発注者・設計者の安全衛生責任を推進してゆくべきと思いますし、非常にプラスになると思います。また、一番実施しなければならないのは、一人親方の問題です。一人親方はものすごい数にのぼりますが、いったいどれくらいいるのか正確には把握できません。建設業の場合、たとえばある下請け業者に所属していても、実際はそこで請負契約を結んでいて、存在を知られていない一人親方、つまり「隠れ一人親方」といった人もかなりの数います。かつて平成一けた台には、労働者が400万程度しかいない中、一人親方は80万ないし90万がいたと言われていました。今そこにはほとんど手が打たれていませんが、そこに手を打つ必要があるのではないかと思います。現在経産省と厚労省が連携する形で、少し前は中災防と鉄鋼連盟が連携して進めていましたが、大手が上手くいけば中小に波及してゆくと思います。監督官の声を拾ってみると、商工会議所へ行っても「何言って



るんですか」といった感じでなかなか上手くいかない。監督署が指導すべき業者を見つけたいと思っても見つからない、それに対してはこういう連携する政策をうつことによって広げていくべきかと思えます。優先順位はなかなかつけられないのですが、今までは成功事例(・・・通信障害・・・)一方でたとえば構造規格を改訂したり、新しい設備や用具が出たことにより、技術的なバックアップで災害が減っていくものもあります。しかし、先ほども申し上げたように防災団体の非会員で災害発生が多いのは、新たな政策を打って対策を講じていかなければならないのではないかと思います。防災団体と連携して実施したことは成功しているのですが、結果的に防災団体の会員以外の災害をどういうアプローチで減らしていくべきかを検討していかなければならないのではないかと考えます。

三柴 ありがとうございます。一点追加でコメントさせていただくと、安衛研の先生方の職務ないし特徴として(決して失礼な意味ではなく)、自らの研究成果を規制に活かしてほしいという流れを感じます。それをわれわれ文系の制度論者からみたときに、原理原則論としてはそれが正解ではあるのですが、やはり歴史や制度を踏まえないとなかなか思うようにいかないところもあります。防災団体に問題を絞ると、日本が防災団体法を作るときにモデルにしたドイツやフランスでは、労災保険(補償)と予防活動は一体で実施され、予防も強制加入になっています。つまり独仏の場合は防災団体に強制的に入らないといけないことになってるわけです。保険金を拠出するのがいやであれば、防災団体自身が予防に尽力するという、圧力がかかる仕組みになっています。日本の場合、防災団体を作るときに予防と補償は一体化しないまま、補償は厚労省、予防は半民間団体に任せ、業界団体と密接な関係を構築し、労災防止規定にも強制力を付与しませんでした。結果として、防災団体は“研修屋さん”などと揶揄されるようなことにもなってしまったという経過があります。では、あらためて独仏型に変革してゆくべきなのか、それとも日本は日本的にもう少しソフトなやり方で、秩序の中で安全衛生が保たれるように誘導していく方向がいいのか、という問題もあるかと思います。この点いつも悩むところです。

先生方、何かご意見・ご質問はございますでしょうか。よろしいでしょうか。

では高木先生からのご報告は以上とさせていただきますが、非常に重厚な研究を積み重ねてこれ、大変有意義な情報を提供していただきました。ぜひ体系書をつくる時に欲しい情報だと思いました。お忙しい中恐縮ですが、体系書の執筆についてはまず分担報告書という形式から始めていただくようお願いいたします。こういうテーマで脈絡を持って研究に取り組んでこられたことに敬意を表します。

高木 ありがとうございます。

三柴 では、次いで藤森先生による横断的検討課題「産業用ロボットへの接触に関する規制」の経過報告をいただきたいと思いますが、その前にいったん休憩を入れさせていただきます。



三柴 それでは再開させていただきます。次は藤森先生による、「産業用ロボットの特別規制について」と題する横断的検討課題についての研究経過報告をいただきたいと思います。

藤森 藤森でございます。前回の第11回の会合で骨子を報告させていただきましたが、その骨子に基づいて少々膨らませたものを報告させていただきます。私の場合、研究報告というよりも、ロボットに対する規制・規定に関する法律上の体系がどうなっているのかといった点を中心にお話したいと思います。

共有画面に映っている資料「産業用ロボットの特別規制について」（※「藤森資料」とする）の7行目になりますが、「本稿では、この産業用ロボットに係る法令・通達等を一つの例として、労働安全衛生法令の体系・構造について以下の観点から横断的にとらえることとする」というアプローチをとることにします。ここに書いてあるように、4つの切り口がありまして、

(1) 法令改正の背景・必要性

(2) 法令における定義及び適用の範囲（※一般的な定義とは異なる法令上の定義や適用範囲とはいったいどのようなものか、ということです）

(3) 法令における規制の具体化—適用関係（※法令の体系、すなわち法律から始まって規則、場合によっては指針、通達による具体化、適用関係など、同じ法の中でもロボットの場合は特別適用というものがあるので、それを例としてお話しします）

(4) 法令・通達等によるこれからの安全管理（※今回の報告では未完ながら、私自身も問題意識を持っていて、皆さまにいろいろとご教授いただきたいところです）

藤森資料1頁の「1 法令改正の背景・必要性について」に入りますが、一つの災害がきっかけとなり、現在は機能の安全という流れにまで至っています。ここではそれについての問題や課題について説明できればと思います。ここに書いた通り、産業用ロボットは昭和50年代に入って自動車工場等に急速に普及してきたという経緯があります。そのような中、昭和56年に被災者の名前にちなんで「ウラダケース」と呼ばれる事故が発生し広く知られるようになりました。兵庫県で発生したこの事故は、産業用ロボットの周辺機器を点検、整備作業中に、産業用ロボットのマニプレータ(人間の「腕」に当たる部分)に背中を押さえつけられ内臓破裂により死亡したというものです。安衛法は、制定前のいくつかの事故から得られる貴重な教訓を前提として制定されており、特に安衛則を中心として様々な規定が設けられています。中でも機械というものは大きなエネルギーを持っていて、その仕組みも一般的に複雑であるということから、第二編の冒頭である第一章に「機械による危険の防止」と題して広範な規定が置かれています。機械については安衛法や安衛則の制定後も、機械設備に関する条文が追加され、安衛則も当初は678条であったのが現在では千を超える状況になっています。藤森資料1頁の下の方になりますが、機械といってもその範囲は広く使われており、それに伴って労働安全衛生規則においても工作機械はじめ幅広く規制がなされています。前回も申し上げましたが、私が興味を持ったのは、ウラダケースの際に関与した監督署は統合され他の監督署になっていますが、その辺りの資料ももう少し詳しく集めることができれば、その後の法改正などに関する対応の詳細も検証できるのではないかと思います。

藤森資料「2 法令における定義・適用の範囲について」に移りますが、ロボットという言葉はここにも書いてありますように、ちょうど100年前の1920年の戯曲において作り出されたという経緯があります。そして、産業用ロボットは一般的にどのような定義がなされているかといえば、ウラダケースの2年後である昭和58年に安衛則が改正されましたが、その当時の広辞苑（第3版）では、「人間の上

肢に似た機構をもち、プログラムあるいは計算機からの指令によって多様な作業をすることのできる機械。視覚を備え、また移動できるものもある。物体の移動、工作機械の操作、組立・塗装・溶接などに用いる。」とされています。近年の広辞苑（第7版）でもほぼ同じ内容となっています。これに対して法令における「産業用ロボット」とは、条文をそのままみてみると、「マニプレータ及び記憶装置(・・(略)・・)を有し、記憶装置の情報に基づきマニプレータの伸縮、屈伸、上下移動、左右移動若しくは旋回の動作又はこれらの複合動作を自動的に行うことのできる機械(研究開発中のものその他厚生労働大臣が定めるものを除く。）」と定義されています(安衛則第36条第31号)。法律上の定義というものは、定義をズラズラと書くよりも関連した箇所から引用し、たとえばロボットでいえば安衛則の第36条第31号・・・これは機械の中でも相対的に危険なものということで、これに関連する業務に従事する労働者については事業者は特別教育を行わなければならないとされています。定義にあたっては、特別教育の必要性がまず先にあり、そこで産業用ロボットの定義がなされているわけです。後ほど説明しますが、災害事故の後に設けられた産業用ロボットの安全規制は、条文でいうともっと後の箇所に規定されていますが、定義規定はこのように前の位置の特別教育のところに規定されています。「マニプレータ」とは、「人間の四肢に類似した機能を有し、「腕」に相当するもの(アーム)、記憶装置とは、マニプレータの動作の順序、位置、速度等の情報を記憶する装置」とされていますが、この辺りは法律を受けて通達で定義されています。

その下に行きまして、「労働安全衛生法令は、事業者に対して職場における労働者の安全と健康を確保することを目的とし(第1条)、この目的を達成するために危害防止基準を確立し、事業者に一定の措置を講じることを要求している刑罰法規であり、規制・措置の対象としての観点から罪刑法定主義に則り定義や適用の範囲が定められて」います。ここは重要なポイントで、定義における相対性と関連して、危険というものも相対的なものです。この会合でも何回か議論された、労働者に「危険を及ぼすおそれ」、「危険が生じるおそれ」などといったものと関連することですが、ここでいう危険も相対的な一面があります。産業用ロボットの問題においても、そのような相対的な性質が見受けられるところです。

その下に移りますが、「産業用ロボットは、予測しがたいマニプレータの動き、ノイズ等によるマニプレータの誤作動等、これまでの機械には見られなかった産業用ロボットに特有の危険性が存在し」・・・先ほど出たウラダケースの場合もそうでしたが、停止していた状態の産業用ロボットに、被災者が背中を向けて作業をしていたところ、突然ロボットが作動を始めてマニプレータに背中を押さえつけられるといった、特有の危険性があります。そのため、「それまでの労働安全衛生規則の「機械」に対する措置のみでは対応できないこととなった。」ということで、先ほど述べた産業用ロボットという観点から定義や規制をしたわけです。そして、「このような観点からすれば、上記により産業用ロボットの定義に該当するとしても」・・・たとえばあまり出力の大きくないものは「労働者に危険が生ずるおそれのないもの」として産業用ロボットの定義から除外されるといったように、あくまで相対的なものということです。有機溶剤についても有機溶剤中毒予防規則の対象は44種の有機溶剤ですが、一般的な有機溶剤は400種類以上あります。その中で規制対象を44種に限定しているのが特徴です。なので、「定格出力80ワット以下の駆動用原動機を有する機械、機械が小さくて接触しても災害に結びつく危険性が極めて少ないもの、マニプレータが1つの動作の単調な繰り返しのみを行うため、動作が容易に予測できるもの、マニプレータの可動範囲が狭く当該マニプレータに挟まれる危険が少ないもの等は、いずれも労働者に危険が生ずるおそれのないものとして、告示により産業用ロボットから除外されて」います。このよう

に、定義や適用範囲については、法令上特有のものがありますので、この点はしっかり押さえておかなければなりません。産業用ロボットはこの点に関する一つの例であって、他の安衛法令にも同様のことが言えます。その上で、適用除外や特例を設ける仕組みになっています。濃度、曝露する時間、機械の能力の大小、といった点から個別的に危険を及ぼすおそれが有るか無いかの線引きをするわけです。

藤森資料2頁、「3 産業用ロボットにおける規制の具体化について－適用関係」ですが、以上のような性格を持つ産業用ロボット関連の規定は、具体的には労働安全衛生規則第150条の3、つまりリスクアセスメントの規定と同じく挿入条文としての枝番号が付されている規定ですが、同条以下に定められています。産業用ロボットについては、先ほどの特別教育の規定を除くと、4か条の条文によって規定されています。これらの条文に基づいて告示や通達が規制内容を具体化するという仕組みになっています。藤森資料3頁3行に書いてありますように、「産業用ロボットは、上記の定義で定められるように、一定の動作を自動的に行うことのできる機械であり、かつその用途について汎用性が認められる機械である」というところに特徴があります。産業用ロボットも機械の一種ですから、労働安全衛生規則第二編・第一章・第一節の「一般基準」の規定が一部を除き適用されます。たとえば合図の規定(第104条)について、産業用ロボットの適用の場面があるが、特別規定にはないので、一般規定である同条の適用を受けることとなる」ということが通達でも確認されています。また、改正により新たに追加された特別規定として第9節「産業用ロボット」の規定(第150条の3から第151条までの4か条まで)が適用されます。

産業用ロボットのもう一つの特徴として汎用性、すなわち様々な用途に用いることができますから、旧来の一般規定や各種機械に関する規定が適用されます。ロボットは、腕から先の手の部分を付け替えたりして使用する場面があるので、そういう意味でロボットは「半完成品」ないし「中間完成品」などといわれることもあります。あるいは周辺の関連機器とともに使われるという特徴もあります。そういうことから、様々な使い方があり、工作機械として使われるのであれば工作機械の規定、木材加工用機械としてであれば木材加工用機械に関する規定、食品加工用機械であればその関連規定といったように、それぞれの該当規定が適用されることとなります。

藤森資料3頁「3 産業用ロボットにおける規制の具体化について－適用関係」の(1)で指摘した「第1節一般基準」である第101条から第111条までの規定が、その一部を除いて(下記(3))、適用される。」という部分の「その一部を除いて」ですが、「(3) 産業用ロボットによる労働災害を見てみると、産業用ロボットの作動における異常、関連機器との連動に不都合が生じたりした場合に・・・」と書きました。ウラダケースがそうでしたが、異常が発生してその確認の際に被災した事情があったわけです。もともとは一般規定である安衛則第107条があり、これは掃除や給油、調整などに際して運転を停止しなければならないとする規定ですが、機械を停止しないことによって非常に多く発生する災害を想定しています。産業用ロボットについては、類似の規定である安衛則第150条の5が新たに設けられ、本質的な構造は第107条と同じですが、両者は一般規定と特別規定との関係になり、競合する場合には第150条の5が特別規定として優先適用されることとなります。

藤森資料3頁「4 産業用ロボットに対するこれからの安全管理について」は、今後報告すべき課題とさせていただけますが、まずは「隔離から協働」という流れです。すなわち、機械と人との隔離から、共に働くという協働の場面にシフトする動きの典型的な例が産業用ロボットであるといえます。まずは、4の冒頭に書いてある通り、「産業用ロボット運転中に、労働者がその可動範囲内に立ち入ることがあれば、



接触による労働災害が発生するおそれが生じることとなることから、次のように定められている。」「事業者は、産業用ロボットを運転する場合(教示等のために産業用ロボットを運転する場合及び産業用ロボットの運転中に次条に規定する作業を行わなければならない場合において産業用ロボットを運転するときを除く。)において、産業用ロボットに接触することにより労働者に危険が生じるおそれのあるときは、さく又は囲いを設ける等当該危険を防止するために必要な措置を講じなければならない」(安衛則第150条の4)。ここでいう「さく又は囲いを設ける等」とは、藤森資料4頁の枠内にあるように、産業用ロボットの「運転中」＝「危険が生じるおそれがあるとき」ととらえ、この場合に「危険を防止するため必要な措置」として(根拠条文は安衛法第2条第1号)、「接触防止措置」ということでさく、囲いの設置等を講じることとされています。まず第一に、要は「隔離」として、立入禁止としての(※文言上“立入禁止”という語句は用いられていない)柵や囲いの設置が義務づけられているということです。「産業用ロボットは、可動範囲、すなわちマニピュレータその他の産業用ロボットの各部の動くことができる最大可動範囲内に労働者が立ち入るとすれば、接触による危険が生じることとなるので、事業者は、「さく又は囲い」を設けることによる立入禁止措置を義務づけている。」これが基本としての隔離のための措置です。そして、この条文や他の条文にもしばしば見受けられ、安衛法の現場での難しさにつながりますが、「さく又は囲いを設ける等」の“等”です。ここは通常、法令の委任に基づいて通達等で具体化される場合があります。ここでは、「さく又は囲い」に限定せず、「産業用ロボットに接触することにより労働者に危険が生じるおそれ」のない場合になるものとして、通達(昭和58.6.28基発339)により以下のように具体化されています。

- ①光線式安全装置、超音波センサー等を利用した安全装置、安全マット等
- ②「ロープ、鎖等の設置」＋「運転中立入禁止」の表示＋「労働者への周知徹底」
- ③監視人の配置による立入禁止措置
- ④監視装置(モニターTV)の設置　＋　接近時運転停止措置

以上が「さく又は囲い」等として、通達で書かれているわけです。

最後になりますが、藤森資料4頁(3)で、人とロボットの隔離から協働への動きについて書きました。ロボットの目的の一つは省力化ということもあるのですが、技術の進歩に伴って、通達の改正(平成25年12月24日基発第1224第2号)により、人と産業用ロボットの協働作業が可能となる基準が示されており、大きく分けて2つの点からなります。一つはリスクアセスメントで、ロボットに特化したリスクアセスメントです。ここにも書いたように、危険性による「負傷の重篤度」及び「発生の可能性」という2つの度合いによって見積りますが、その際にはロボットの特殊性から、次の点に留意しなければならないとされています。すなわち、マニピュレータ等の力及び運動エネルギー、マニピュレータ等と周辺構造物に拘束される可能性つまり距離や力の問題です。さらには、マニピュレータ等の形状や作業の状況といったことが、通常のリスクアセスメントに加えて留意されなければなりません。もう一つは、国際標準化機構(ISO)の産業用ロボットの規格により設計、製造及び設置された産業用ロボットを、その条件に基づき適切に使用すること。以上の要件のもとで、隔離から人とロボットの協働作業という流れになっています。さらにこれと関連して、機械安全や機能安全ということが近時一般的にいわれていますが、特にロボットにおいては技術の進歩が激しい電子や電気関連の技術を用いて機械等の安全確保を講じる措置が規定されています。これは指針ベースで行われています。この辺りの問題は今後もっと膨らませて研究していきたいと思いますが、冒頭で申しましたように、ロボットは省力化等の目的のためには非常に便利であり、人間の

作業の代替が目指す目的のひとつであり、機械安全や機能安全を今後どのように確保していくべきか、その辺りの兼ね合いを検証する際には、技術的な専門家の先生方にご教示いただくなどして今後の研究を詰めていければと思います。

以上でございます。

三柴 ありがとうございます。では、ご質問・ご意見ありましたらお願いいたします。というより、例によって私が口火を切らせていただきますが、先端の規制に関する有益な情報をいただきましてありがとうございます。お話の流れとしては、産業用ロボットという規制対象が近年あらわれてきたところ、もともと機械については伝統的な規制があったけれども、産業用ロボットについて、労働者の視点で見た場合の動作の不確実性や複雑さに伴うリスクに対応するための規制を設けてきた、しかし労働者が機械と仲良く付き合っていく必要があるので、法令による規制の範囲はある程度絞って規制の網をかけない部分も明らかにする、簡潔にまとめるとそのようなお話の筋をうかがうことができました。

あらためてお伺いしたいのは、以上のような流れがあるとなれば、技官など技術に詳しい人が製造の中核にいて、必要とあれば法令の改正もして通達や規則を作ったりしてやりやすいところからルールの整備をしていくという、現在のルール整備の形でこのような問題も網羅できているということなのか、つまり安衛研等研究所の方々も再発防止策を研究し、それをルールに反映するという、今のルール作りの仕組みの中で十分網羅されているということなのか、あるいはそれでは間に合わなくて、免れるリスクというのが産業用ロボットにも出てきてしまうので、そういうところには新たな規制の方法論をもって対応していかなければいけないのか、藤森先生としてはその辺どのようにお考えでしょうか。

藤森 三柴先生が最初に仰った、“規制の網をかけない”ということの意味ですが、規制をかけていないということではないということは自明の理です。私の報告の中でも申しました通り、産業用ロボットは大変便利で省力化にも資するというメリットはありますが、もともと人間の代わりに仕事をさせて省力化を図るという意図に加えて、当初典型的であった有機溶剤の吹付用ロボット、あるいは2800か所にも及ぶ自動車のスポット溶接用のロボットなどのように、省力化というだけでなく有害物への曝露防止といった安全衛生にも資する機能や目的がありました。やはり安全の担保がしっかりしていなければならないという考えが根本のところであり、旧来の手法である囲いなどのほか、工学的管理などを活用して安全の担保を図ることが今後の課題であると考えています。

三柴 ありがとうございます。規制の体系としては、そもそも機械安全の確保については法第21条に定められているし、何よりも努力義務であるもののリスクアセスメントによってリスク全般に網をかけるという形にはなっているわけです。危ないものに関してはきちんと調査して対応しなければならないという体系はすでに整備されているわけですが、現に災害が生じて再発防止策も明確になっている部分については基準を設けたうえで、できれば罰則も設けて厳しく取り締まっていくべきかと思います。しかし、技術的にも経済的にも規制によって縛りすぎると新しいものができなくなってしまうし、極論すると危ないものは作るな・使うなということになってしまうので、常にさじ加減というものが技術的な知見も踏まえながら調整する必要があります。藤森先生ほか技術系の先生方にお尋ねしたいのですが、産業用ロボットの現行の規制について過不足がなく、さじ加減はちょうどいいという理解でよろしいでしょうか。



藤森 私としては先ほど申しました通りですが、私も技術系の先生方にご意見をうかがえればと思っております。唐沢先生、よろしいでしょうか。

唐沢 貴重なご説明ありがとうございました。私は昭和58年当時安全衛生部におりましたが、私の同僚が産業用ロボットに関する規則を改訂するための担当者でしたが、昭和58年当時の規則の内容と現在の規則の内容は、本質的にはほとんど変わっていません。いわゆるマニプレータがあるものを中心になっています。その後、産業用ロボットによる災害事例がどの程度あるのか、安全関係の資料を当たってみたのですが、産業用ロボットによる死亡事故については収録されていないので、三柴先生が仰ったように、現行の規則で十分なのかどうかといえば、ある程度は十分なのかもしれません。ただ産業用ロボットは発達や進化のスピードが速いものですから、いろいろな産業用ロボットが開発されているので、リスクアセスメントに関する努力義務というものが法で定められていますから、ロボットの製造者や使用者はある程度の対応を取っているかもしれません。私としては、現行の産業用ロボットに関する規定で十分網羅されているか否かについては、未だ検討の余地があるものと考えます。

三柴 唐沢先生が系統的に調べている災害データの取り方、重篤度をきちんと捕捉できているかとか、ヒヤリハットなども捕捉できているか、そうしたデータをどのように集めて分析しているのか、そういったところにも問題が関わってくると思うのですが、少なくとも現状データとして産業用ロボットに関する規制の改正を促すような情報はあまりあがってきてはいないということですね。

このほか、技術系の先生でご意見等いただける方はいませんかでしょうか。

井村 確認というか、一点ご教示いただきたいのですが、産業用ロボットにはいろいろなタイプがあると思うのですが、構造的な点での規制は現在のところ行なわれていないという理解でよろしいのでしょうか。どのように作動するか、たとえばどのような製品をどのように作るかといった構造です。ボイラーやクレーンなど私が担当している分野においては、特定機械の扱いについての規制が行われていますが、その辺について産業用ロボットでは動作上の危険性に対して安全対策をするという形で規制が行われているという理解でよろしいでしょうか。

藤森 先ほどの報告で説明不足だったかもしれません。藤森資料2頁で、法律の定義自体が相対的なものである旨お話ししましたが、法律上は「マニプレータ及び記憶装置(・(略)・)を有し、記憶装置の情報に基づきマニプレータの伸縮、屈伸、上下移動、左右移動若しくは旋回の動作又はこれらの複合動作を自動的に行うことのできる機械(研究開発中のものその他厚生労働大臣が定めるものを除く。)」と定義されています。それとともに、2頁の下の方に書きましたが、機械の能力や大きさなど構造的な面が問題になります。すなわち、「定格出力80ワット以下の駆動用原動機を有する機械」、あるいは「マニプレータが1つの動作の単調な繰り返しのみを行うため、動作が容易に予測できるもの」、「マニプレータの可動範囲が狭く当該マニプレータに挟まれる危険が少ないもの」などです。井村先生が仰った構造的な問題であれば、たとえば告示で定められている「定格出力80ワット以下の駆動用原動機を有する機械」などがそれに含まれるのではないかと思います。特に構造規格による枠組みは設けられてはいません。

唐沢 補足させていただいてよろしいでしょうか。

三柴 お願いします。

唐沢 今藤森先生が仰ったとおりなのですが、産業用ロボのような非常に進歩が激しい機械設備について、構造規格で一定の要件を義務づけるのは難しい面があります。そういう問題があるので、産業用ロボットは第42条の対象たる機械には含まれず、また昭和58年当時の段階ではそのような規制もできなかったわけです。

玉泉 構造規格の問題ではないのですが、昭和58年9月1日に産業用ロボットの安全基準と技術上の指針が出されています（※昭58・9・1 技術上の指針公示第13号）。産業用ロボットを製造する大きなメーカーは、概ねこの指針をベースに製造していると思います。現場を見ても、ロボットの技術上の指針を参考にして、たとえば安衛則では囲いになっているところ、技術上の指針では安全プラグを抜かないと立入できないといったことが書かれていますので、第42条の構造規格の問題ではないのですが、メーカーではこれに基づいて産業用ロボットを製造していると思われま。

三柴 ISOの規格に言及されていたので、JISでも一応対応する規格はあるわけですね。

藤森 唐沢先生も仰っていましたが、藤森資料4頁でもJISでの対応について記載しました。

玉泉 技術上の指針は安衛則第28条だったと思いますが、これに基づいて技術上の指針が多く出されていますので、労働安全衛生法の立場からいうとこれが一応のメルクマールになるのではないかと思います。

藤森 先ほどお尋ねの産業用ロボット自体の構造というのは難しいのですが、今のお話の指針とは安全装置等であって、ご質問は産業用ロボットの構造そのものの問題であると理解していたもので、それについては先ほど唐沢先生が仰ったように一つの構造規格を作ることは難しいと思います。玉泉先生のお話に出た安全プラグのルールなどは、構造規格の周辺の安全装置等の問題であると思います。ご質問の内容は、クレーンやボイラーと同様機械そのもので第42条の対象となるものであって、産業用ロボットに関しては、そのような規制はないのではないかとお答えしたつもりです。指針の件については、お陰様でよく分かりました。

三柴 新任の法学系の先生のために少々コメントしておきますと、要は安全対策をするときに「3ステップアプローチ」という考え方があります。まず機械の場合であれば構造自体を安全に設計するところから始まります。しかしそれだけではリスクが残り、対応が難しいという場合には、安全装置や防護柵を付けるといった二次的な方法を取り、それでもなお残留リスクがあるにもかかわらずその機械を使用しなければならないという場合には、人の教育を行う、あるいは管理体制を整えるというやり方で、順繰りに対応していくというやり方です。先ほどの井村先生のご質問は、本質的に安全な設計をさせるようなルールは

存在しないのかというものであり、これに対して安衛法上そのようなルールはないものの、二次的な対策に関しては指針が出ているのではないかというお話です。他方で、法令ではないがISOの国際規格やそれを拾っているJIS（日本工業規格）においては、そもそも設計や構造の段階で一定の規格化が図られているというお話です。産業用ロボットに関してはこの辺りで区切らせていただきます。

最後に角田先生からお話しいただきたいと思います。内容は、安全コンサルタントをおつとめなので、現場的な視点からみた安全衛生コンサルタント制度とはどのようなものなのか、また、企業の労働安全衛生の実際をあくまで現場的な視点から説いていただくということです。

（※共有画面に「労働安全コンサルタントとしての現場活動の紹介と所感」（角田資料））

角田 角田です。これまで発言させていただく機会がなかったのですが、今回このような形でお話させていただきまして、ありがとうございます。私は労働安全コンサルタントなので、現場での活動とそこで感じた企業に関する一コンサルタントとしての所見ということでお話をさせていただければと思います。私は平成27年（2015年）に労働安全コンサルタントになりましたので、コンサルタント歴は5年ほどです。そういう意味ではまだ駆け出しですので、私がコンサルタントの代表などとはおこがましくて言えませんが、一個人の意見としてお聴きいただければと思います。また、コンサルタント業務とあわせて企業にも勤めておりますので、企業勤務のコンサルタントという立場です。

今回、一つには労働安全コンサルタントの活動状況について、私自身の活動と、現在日本労働安全衛生コンサルタント協会兵庫県支部の役員に任じておりますが、その中で同県内の他のコンサルタントの活動がみえてくるところがありますので、それらも踏まえたいうえでどのような活動がなされているのか、などといったことをお話しできればと思います。

そして二つ目として、メインのテーマと位置付けておりますが、法令の中に様々な用語が出てきますが、実際にどのような使われ方をしているのか、現物の機械はどのようなものなのか、分かりづらくイメージしづらいところがあると思いますので、私が撮った写真をご覧いただこうかと思っています。そして、安衛法第28条の2に規定されているリスクアセスメントがありますが、実際にどのようなことをしているのか、訪問先の企業に許可を得たいうえで事例をご紹介します。そして、私は建設現場のパトロールを実施することが多いのですが、その中で感じた安全活動・意識、先ほど高木先生のご報告は非常に納得感のあるものでしたが、それを補強できる現場の実例として説明できるかと思います。

まず、労働安全コンサルタントとしての業務の説明に入りますが、単発業務とは依頼を受けた場合の仕事です。私はコンサルタントとしてブログを開設・執筆しておりますが、これが営業活動となっていて、ブログ経由で依頼を受けることがあります。その際の依頼のほとんどは、研修と安全パトロール・安全診断がメインになっています。また、顧問先企業と契約をした場合、パトロールや研修に加えて年間の安全衛生計画や設備等のリスクアセスメントを実施したりしています。仮に労働災害が発生した場合にはそれらへの対応や、監督署への届出のサポート等をしております。労働安全コンサルタントの試験には専門区分があり、土木、建築、機械、電気、化学などに分かれています。これらの区分に従って受験するわけですが、実際にコンサルタントになってからは専門区分に限定されることはありません。業務依頼を受けるか受けないかは本人の判断次第です。私は土木が専門ですが、建築現場でのパトロールや診断を行うことも多いです。ただし、あまりにも専門が異なる場合、たとえば化学プラントの診断を依頼されてもできませんので、その場合には他のコンサルタントの方にお任せすることも多いです。ただ、土木専門であって

も化学や電気に詳しく対応可能というのであれば、他分野の依頼を受ける場合もあり、最終的には個人の判断に委ねることになります。コンサルタントは労働安全と労働衛生に分かれておりますが、この区分に関しては専門での区分に比べ、明確に棲み分けされていると思います。衛生の仕事に関しては、安全の専門家は受けることはありません。この後、パトロールについては写真をお見せしながらお話ししますが、研修のお話をしますと、事業者から特別教育の依頼を受けることが多いです。あるいは、職長や安全衛生責任者教育など法定教育があります。個人で受けることはできませんが、技能講習の講師をしたり、それ以外ではオーダーメイドの研修をすることが多いです。たとえば、先日私がお受けした研修は、建設現場でよく行われますが、「危険予知活動」(KY活動)について作業員の人たちに教育を行ってほしいとの依頼でした。先ほど安全と衛生とで区分が明確である旨説明しましたが、特別教育などに関して言うと、いずれも限定・区分なしに実施することが多いです。例を挙げると、安全コンサルタントが酸欠のような衛生に関わる特別教育を行う、あるいは衛生コンサルタントが足場の組立て等の特別教育を行うといったことは珍しくないと思います。ただ、知識不足を補うために中災防でインストラクター研修が行なわれていて、私もいくつか受講しております。また、職長教育では中災防でRST研修を実施していて、これを修了している人も多いです。これは個人としての活動ですが、仕事の依頼としては事業者・会社から依頼を受けることが多いです。事業者の依頼のチャンネルというか受け方ですが、一つにはコンサルタントの方はもともと年齢層の高い人が多く、平均すると50くらいでしょうか。私は40代ですがまだ若手の方で、兵庫県においては私の次に若い安全コンサルタントの方は60歳です。なので、あるコンサルタントがリタイアされたタイミングで活動を始める人が多いので、もともと一の事業者と契約したり顧問先になったりすることが多いです。それと、コンサルタント会や災防団体から紹介される仕事を受けたり、業務委託を受けたり、あるいは頑張れる人は自力で営業したりとか、などしています。私に関しては、ブログが勝手に営業活動をしていて、さほど積極的に営業活動はしていないのですが、それなりにコンサルタントとしての仕事をいただいております。

事業者が依頼をするきっかけは、私が知る限りではほとんどの場合労災が発生したことが契機になっています。労災とまでは言えなくても労働者が怪我をしたなどがきっかけで、各種団体に相談したり、コンサルタント会のホームページを見つけたうえで相談して依頼してきたというケースが多いです。ただ、推測ですが、全体の活動状況としては、アクティブに活動されている方はさほど多くはないという印象です。兵庫県の中でもそう感じます。その中の指標となるものが、生涯学習制度と思われまので、紹介させていただきます。これは、活動に対して単位を付与して単位数が一定を超えると生涯学習認定の称号が与えられます。労働安全コンサルタントの称号はCSP、衛生コンサルタントで保健衛生の場合はCOH、衛生コンサルタントで衛生工学の場合はCIHとなっています。これらは250単位、活動の時間や活動内容によって異なるのですが、一定水準をクリアして相応の活動をしないと得られないようになっています。これらの実態をみると、角田資料2頁掲載の表になるのですが・・・コンサルタント会の正会員のデータなので実際に資格を持っている人を全てフォローしているわけではないことをご了承ください・・・正会員数2584人のうち認定者・称号使用許可者が265人で約10%になります。これは労働安全コンサルタント会の機関誌から引用させていただいたデータですが、称号使用許可者が正会員のうちの10%ほどですので、実態としてアクティブに活動している割合もこの程度ではないかと推測されると思います。私が所属する兵庫県およびその周辺である近畿地方の他府県でのお話を漏れ聞いたりするなかでも、やはりメインで活動されている方というのは名前がいつも出てくる方が多いです。あらためて兵庫県を調べて



みると、やはりよく活動されている方は頻繁に名前が出てくる10%ほどの方ではないかと思います。もちろん、名前を出さずに活動されている方もたくさんいるので、ひとつの指標でしかないのですが、おおむね実感として兵庫県では正会員の10%程度の方がアクティブに活動され、全国的に見ても近い数字ではないかと思います。以上はあくまで推測ですので、根拠に乏しいものであるということをご了承ください。

三柴 よろしいでしょうか、角田資料2頁掲載の表は、兵庫県のデータでしょうか。

角田 いえ、全国のデータです。

三柴 次のデータも全国でしょうか。

角田 その通りです。これは、上の表を円グラフにしたものです。

三柴 了解です。それと、円グラフ中の「非許可者」とはどういう意味でしょうか。

角田 これは、生涯学習制度は登録をしなければならないのですが、登録して一定の単位を取得すると称号を得られます。しかし、まだそこまでの段階に到達していない人が29%の非許可者ということになります。

三柴 ありがとうございます。

角田 続けさせていただきます。私自身の周辺をみても、アクティブに活動されている人の方が少ないというのが実感です。角田資料2～3頁になりますが、その理由として考えられるのは、まず安全以外のところで活動を主とされている人が多いと思われまます。たとえば、産業医、技術士、または社労士など、コンサルタント以外の活動を主としている人です。それから、私もそうですが、企業に所属している人です。コンサルタント業務は所属企業の業務の合間に行うため、メインではなくなります。そして、何よりも「仕事数が少ない」と思われまます。コンサルタント会から紹介される仕事は少ないですし、もしくは厚生労働省からの委託業務などもあります。せいぜい年に1件あればいいほうです。仕事の絶対数が少ないわけです。また、仕事を得るための営業活動を自発的に行っている人が少なく、非常に稀です。コンサルタント会の兵庫支部にも毎年何人か加入されますが、だいたい仕事まわしてもらえることを期待して加入される方が多いと思います。ですから自分から活動するということが少ないかと思われまます。次もまた大きな理由で、高齢化です。安全に関しては年齢層が高いので、登録はしているけれどもさほど積極的ではないという方が多くいるような印象を受けます。さらには、私もやっけていて思うのですが、労働安全・衛生コンサルタントの知名度が低く、安全衛生に関わっている事業者は知っていますが、そうでない人にはまったく知られていません。労災事故が発生したときにはじめて、そんな制度や人材があったのかと気づき、アドバイスを求めるという人が多いものと思われまます。以上のような理由で、アクティブに活動する労働安全コンサルタントが少ないようです。



では、メインのお話になりますが、私は建設現場のパトロールに出向くことが多いので、パトロールを先に紹介します。事業者の方から依頼を受け、日時を決めて現地集合もしくは事業者の事務所に集まって一緒に連れて行っていただくこともあります。その際に店社パトロールの方と同行することもありますし、現場の責任者、つまり統括安全衛生責任者であったり、あるいは現場工事の所長と一緒にまわることが多いです。店社パトロールは、安全衛生の専門部署を持っているそこそこ大きな会社ですので、多くの場合総務の担当者の方が多いという印象です。そして、現地に行って現場の内容説明を受け、パトロールを行います。パトロール上で講評し、場合によっては作業員の方に講習をしたり、講話をしたりすることもあります。最後に報告書を提出するというのが一般的なパトロールの流れです。

写真をご覧いただきたいと思います。私は兵庫県に住んでいますが、ブログを通じてご縁があって仙台の会社とコンサルタントとして契約をしており、毎月のように宮城県に出向いてパトロールをしております。その中で、最近行っているパトロールの現場を紹介させていただきます。ちなみに、お見せする写真は研修等の資料の中でのみ使用する許可を得ておりますので、その点ご了承ください（※本議事録にも不掲載とさせていただきます・・・原）。

これは宮城県の女川町のトンネルの復興工事の写真です。外部は貫通して周りのコンクリートをつけている工事です。次いで、東松島市の建築現場ですが足場が組まれているのがわかると思います。自然学校の建てをつくっている様子です。ご覧のようにわりとゴチャゴチャしている感じですが、内部は塗装の作業をしているところです。ちなみにここは熱中症対策の建屋で、この中でかき氷を作れるという工夫をしている事業者もいます。このほか、宮城県での安全パトロールの様子を紹介したいと思います。これは仙台市の荒浜小学校というところで、津波の被害を受けたのですが、震災遺構として保存のための耐震補強工事を行っている様子です。内部には当時の在校生のメッセージが残されたままになっていて、これを見ることができるようになっています。次いで石巻市の防潮堤工事です。海岸沿いに高さ10m以上の防潮堤が作られています。そして、これは気仙沼市の三陸道工事です。橋の工事を行っていますが、防潮堤工事とあわせて行っている様子です。ここからは、車両系建設機械の紹介になりますが、先ほどの高木先生のスライドにもありましたが、条文上はドラグショベルなどと称されるものです。現場ではバックホウと呼ばれることが一般的です。中にはユンボ、あるいは油圧ショベルと呼ばれることもありますが、土木建築の現場で用いられる掘削機械です。そしてこれはロングアームと呼ばれるものですが、このブームの部分が非常に長いので、遠くまで伸びて深く掘ることができる機械です。次いで、これは締固めの機械で振動ローラーというものです。この部分が鉄輪になっていますが、ここが細かく振動して地盤を締め固める機械です。これは正面からの写真がなかったので後ろからの撮影になりますが、名前を耳にしたことがあると思います。ブル・ドーザーです。地面をならしたり、履帯の部分、クローラの部分で踏み固めて締め固めるという役割があります。これは地盤改良機、アースオーガという種類になりますが、このドリルの部分を地面に突き刺して、コンクリートを内部に注入して地盤を固めるものです。建物の基礎工事に使われることが多いです。そしてこれもいい写真ではないのですが、赤い車がコンクリートポンプ車です。ブームが伸びていて先端部分が写っていませんが、ミキサ車からコンクリートを受けて圧送します。この建物は5階か6階くらいの高さだったと思うのですが、コンクリートを打ち込むところまで運ぶことができる機械です。そしてこの機械が不整地運搬車で条文にも出てきたと思います。足の部分が履帯すなわちクローラになっているので、このように砂地の部分でも走ることができる機械です。これはクレーンの中でラフタークレーンと呼ばれる種類のものです。タイヤとナンバープレートがついているので、自走して

現場に来ることができます。写真のクレーンは25トン吊りです。この工事はポンプの排水機場の設備を運んでいるものです。そしてもっと大きな機械になると、クローラークレーン、すなわち足下がクローラ（履帯）になっているのがわかると思います。これくらいになるともはや自走することができませんので、バラバラに現場に運び入れて組み立てて使用することになります。そしてこれも土木の現場で使われますが、移動式クレーン機能付きドラグ・ショベル、つまりバックホウです。この先端にフックがあり、これで吊ることができます。写真は鉄板を吊っているところですが、このようなものも現場では使われています。これは高所作業車で、垂直降下式とブーム式です。

ここからは工事の様子をいくつか見ていただこうかと思えます。これは防潮堤工事ですが、場所は石巻の海岸で、石巻湾付近です。下部と上部が重なってくると、最終的にこのような形になってきます。このコンクリートの部分も実は下部から打ち増した部分で、そこからの高さでいうと、10mくらいの高さの防潮堤になります。次の写真は、建築構造物の地下の部分を作っている様子です。鉄筋が組まれているのが分かるかと思えます。そしてこれも安衛則の条文に出ていると思えますが、土止め支保工の一例です。もっと大規模なものもあるかと思えますが、掘削した場所に矢板を打ち込んで、腹起しで補強して地盤がずれないようにするというのが土止め支保工です。次の写真も土止め支保工の例です。川の掘削のときに左右に矢板を打ち込んで腹起しをしている様子です。次の写真は橋梁工事で橋の上の部分です。鋼材で鉄橋を組んでウィンチでどんどん先に送り出すことで橋をつくっていく様子です。全体が見えにくい写真ですが、橋梁工事の上部工の部分です。下部工が次の写真で、橋脚の工事です。これはだいたい仕上がっているのですが、ここに先ほどの写真の橋梁が乗っかる形になります。次の写真は道路造設、カルバートといいますが、中の空間の部分が車道と歩道が通るようになっています。石巻での工事の様子です。次にトンネル工事です。トンネル工事を見る機会はなかなかないと思えますが、写真を何枚か準備しました。トンネル工事は内部でダイナマイトで発破した後、掘削して土砂を運び出し、周りをコンクリートで固めていくというのが一般的な流れです。この写真は発破後の掘削の状況です。そして、掘削したところで周囲にコンクリートを吹き付けていきます。末端の部分の切羽といいますが、切羽にコンクリートを吹き付けています。そしてコンクリートが外れてこないように、内部にアンカーを打ち込んでいます。この写真が舗装前の様子です。天井、地盤、路肩の部分も出来上がって、あとは舗装するだけの状態になっています。それから、これはシールドマシン、推進工法、つまり発破を伴わずに機械でどんどん掘り込んでいくもので、大型の機械を見る機会がありましたので紹介します。ここの歯の部分で穴をくりぬいていく機械です。次の写真は海上での掘削作業です。次も言葉ではなかなかイメージしづらいと思って写真を追加しましたが、安衛則第539条の2から第539条の9まで、ロープ高所作業に関する規定があります。その一例として、この写真のような斜面上からロープを吊り下げて作業を行うというのがロープ高所作業です。これ以外にもビルの窓掃除などにおいても、ロープ高所作業が行われています。次の写真は建築工事（学校新築）の現場です。右の写真の内部の様子ですが、以下にゴチャゴチャしているかがお分かりいただけたらと思います。つまりいたり、頭を打ったりする危険な状況がたくさんあるというのが見て取れるのではないかと思います。次の写真は分かりづらいかと思えますが、安衛則の条文に出てくる型枠支保工の様子です。写真の上の方に天井、スラブと言いますが、スラブを打つ時には垂直ではなく水平に打つので、下から支えてやらなければいけません。そこに、サポートというたくさんの鉄パイプをつけている様子です。これは解体中の状況ですが、このようにたくさんのサポートがついていることは見て取れると思います。次の写真は足場の様子です。足場には大きく2種類あり、枠組み足場と単管足場で、写真は枠組み足場で

す。枠組み足場というものは、この部分の枠を上に向かって積み重ねていくことによって組まれていく足場です。この部分が手すりです。こちらが条文に出てきますが「筋交い」というものです。この写真は橋脚工事の枠組み足場ですが、手すりとしては先行手摺があるほか、様々な種類の手すりがあります。次の写真は単管足場ですが、単管足場の代表は鉄パイプで組んでいくのがメインです。しかし、今は見かけることが少ないです。こちらの写真のように、鉄パイプを「クランプ」という機材で固定して組んでいくのが単管足場です。単管足場は、最近はこちらの写真のクサビ緊結式が多いです。クサビ緊結式は、写真のこの辺りを見ていただきたいんですが、縦の支柱のところにポケットなどがついていて、そこに水平材を打ち込んでいきます。水平材を差し入れてハンマーでたたいて固定していきます。このように、クサビ緊結式で足場が組まれていることが多いです。枠組み足場よりもこちらの方が多という印象です。次の写真はダメな足場（安衛則第518条違反）です。足場にもならないのですが、手すりもありません。次の写真も最近見かけたもので、一見足場が組まれているように見えますが違反状態の足場（安衛則第518条、第519条違反）の例です。手すりはあるのですが、中さんという中間部分の支柱がありません。また、幅木という落下物を防ぐものもありません。このように違反状態のダメな例ですが、パトロールにおいてはこういう足場をみかけることも決して珍しくはありません。この写真も現場で見かける悪い例ですが、機械の覆いが外された状態（安衛則第123条違反）です。これは丸鋸という機械で木材を切るものですが、本来であればこの部分に覆い、すなわちカバーがあります。よく見るとここで固定されているのがわかると思います。すでに刃がむき出しの状態違反状態なのですが、非常に少なくなってきましたが時折このようにカバーが外された機械を見かけることがあります。次の写真はグラインダー、いわゆるベビーサンダー、重研削砥石です。これも本来カバーがあるのですが、取り外して径の大きな刃をつけたりとかしています。グラインダーのカバーを取り外した違反状態は、丸鋸よりもよく見かけると思います。こういった足場や機械の違反状態を工事現場で見かけることは、まだまだ少なくはありません。

次にリスクアセスメントの事例です。角田資料5頁は、実際にこういう機械が使われていて、このようなところに危険性を見いだしたりしているという一つの例として見ていただければと思います。この機械は設置されてからすでに30～40年経過していますが、たとえば台座の大きなところがあり足を踏み外すところがある、あるいは機械の中にも隙間があって、そこに手を突っ込むと怪我をする要素があるので、リスクアセスメントではこういったところに注目して、作業方法などの改善を提案します。

いま言ったようなパトロールの経験をふまえて、現場の安全意識について感じる場所をお話します。まず建設業ですが、元請と専門業者が混在作業をしているため、元請が統括管理をしています。主な安全衛生活動としては、安全施工サイクルに従って行われますが、安全施工サイクルとは下図のようなものです。すなわち、朝礼があってミーティングを経て、危険予知活動（KY）をして、作業後には後片付けと終業時の確認となっていますが、どの時間に何をやるかという流れを安全施工サイクルといい、これに従って行われることが多いです。日常的にもしくは月間で連絡調整が行われています。現場では安全活動の中心は危険予知活動（KY）と、車両系建設機械や移動式クレーンの作業計画書を作成しなければなりません。これらがメインになっています。先ほどの高木先生のご報告の中で、元請が主体となった自主的な活動が労働災害防止に寄与したと仰っていました。確かにその通りですが、ただ最近ではそれがただの儀式になっている面も見受けられます。書類を作成するとか、記録するとか、あるいは第三者に検査の際にみられるから作成しているという趣旨で行われているということも見受けられます。小規模な工事になると、安全活動はほとんどなされていまして、現場にふらっとやって来て、仕事だけしてふらっと帰っていく

ということもあります。中でも建設業法上で、毎月4時間以上の安全衛生教育が義務付けられていることが多いのですが、正直にそれを行っているケースはさほど多くないようです。中小規模の工事では、実際にはやらずに書類だけ書いてサインしているというケースも少なくないというのが実感です。理由としては、やり方を知らない、あるいはやるべき内容がない、といったものです。

## 建設現場の安全施工サイクル例

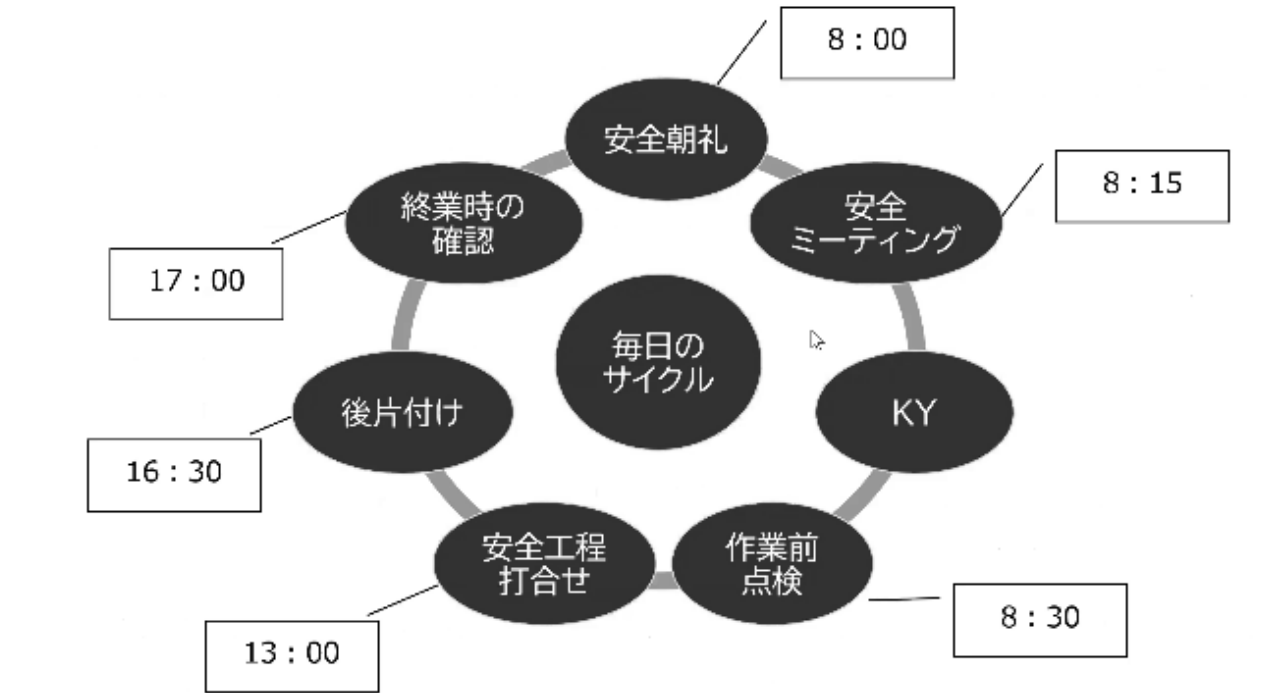

もう一つは、建設業でのリスクアセスメントですが、実施率自体は高いと思われます。ただ、大体は作業手順書とセットとなっていることが多いですけれども、そこに書かれている内容は管理的な対策や保護具程度かと思います。本質的対策や工学的対策を現場レベルで実施することはなかなか難しいので、KYに付随してリスクアセスメントを実施していることが多く、建設業の現場や手順書においては、KYに毛が生えた程度のような印象です。そういう意味ではリスクアセスメントのやり方や考え方自体が上手く伝わっていない、あるいは上手く適用されていないという印象を受けます。

コンプライアンスや安全意識の温度差については、先ほど高木先生が仰っていたとおりで、大企業になると非常に高いですが、専門業者や一人親方、あるいは数名程度の業者になってくると、非常に低いです。工事の形態でみると、公共工事の方が意識が高く、民間になるほど安全意識が乏しいような印象です。安全意識としては、公共工事や大企業つまりゼネコン等は高く、大手のハウスメーカーもそれに準じて高いレベルの安全意識を持っています。規模が小さくなればなるほど安全意識は小さくなり、実際に現場で作業をするのは専門業者が多いのですが、事故を起こして被害を受けるのも専門業者が多いので、その辺りにギャップがあります。すなわち、管理側の意識と実行部隊の意識とに温度差があると感じます。

そして、安全衛生に関する情報の広がりについて現場で感じたことを紹介させていただきます。一次、二次とありますが、高次になればなるほど情報を得る機会は少ないです。たとえば自発的に厚労省のHPを見るなどといったこともほぼないので、情報を得る機会は少ないようです。得るとすれば元請から話と



して聴く、もしくは元請主催の安全研修会などで聴くといったことが多いです。情報も少なく、またどのようにやればよいのか方法論もわからないので、元請などから資料の提供を受け、それを真似て自社に適用していくといったことが多いかと思います。そういう意味では角田資料にイラストをつけましたが、ハンカチの中央をもって上に引っ張り上げると、末端が上がっていくように、元請が主導して情報を得て発信することによって、それに関連する協力会社や下請会社にも情報が伝わっていくような印象があります。情報を得る機会としては、元請が主催した安全衛生協議会を持っていることがあり、その元請から頻繁に仕事を受けている協力会社は協議会に所属しています。これらの協議会で情報が発信されることによってその情報を取得するということが多いです。ただ、情報を知っていても現場で実行するとなると、やはり難しい、あるいはやらなかったり、あるいは情報を知っていながら、例えば保護具を購入するのが金銭的に厳しいので、墜落制止器具などを買換えないといったケースもみられます。なので、金銭的な面でもサポートがないと難しい感じを受けたりもします。

少々長くなってしまいましたが、現場での活動と工事現場での安全活動、安全意識の現状等についての報告でございました。以上です。

三柴 ありがとうございます。今の角田先生のご報告について、ご意見・ご質問があればお願いいたします。

畠中 角田先生、ご報告ありがとうございました。おかげさまで現場のことがよく分かりました。ご報告の中で、安全衛生コンサルタントの仕事が少ないというのが一つの問題点として挙げられていました。労働安全衛生法は、安全衛生改善計画作成の指示制度、そして作成の指示をした場合に労働安全衛生コンサルタントの利用勧奨をするという仕組みを、制度として親切に作っているわけです。なぜ労働安全衛生コンサルタントの利用勧奨制度が上手く回っていないのか、です。これが上手く回っていればそれなりのボリュームの仕事があると思うのですが、その辺り教えていただければと思います。

角田 制度自体の認知度があまり高くないという印象を受けます。正直言うと、私自身もそういえばそんな制度があったかなという印象です。他のコンサルタントや事業者の方から、そういう制度があるというお話を耳にすることがないので、認知度が低いことが原因ではないかと思います。

畠中 特安や特衛の関係で、こういうお話は出てきませんか。

角田 兵庫県の例でいうと、毎年指定業者があると思うのですが、誰が受けているかが支部としてはまったくわかりません。おそらく受けた方が個人的に対応されているものと思われます。以前に法改正がなされ、どの事業者が指定されたか公開されていなかったと思うのですが、私は公開されていないときからコンサルタントを営んでおりますので、制度自体分からない面があります。支部の中でも全く情報が回って来ないというのが実情です。どなたがやっているのか、またそこからどのような広がりが生じているのか、などなど見えていないというのが正直なところですよ。

畠中 ありがとうございました。



三柴 去年、安全衛生コンサルタント会に南先生、石崎先生含め3人でインタビューに出向き、後藤先生にお話を聴きました。以前はコンサルタント会のコンサルタントのリストを作り、特安・特衛の指定を受けた事業者に見せて、どのコンサルタントに依頼すべきかについても多少相談にのるような運用をしていたようです。現在は、個人情報保護法の施行も一つのインパクトとなって、そのような扱いはしていません。聞けば答えてくれるのですが、コンサルタント会の方でも積極的に推薦をしてくれるのかどうか、活動も不透明になってきています。というようなお話がありました。

角田 コンサル会が関与して特安の仕事をつたというお話はここ数年はきいていないです。私が兵庫支部に入ってから4年になりますが、今までに聞いたことはありません。

三柴 さらに言えば、監督官がこの制度を運用しているのか否かという問題も、そもそも論としてあるのかもしれない。この辺詳しい先生いらっしゃいますか。篠原先生、いかがでしょうか。

篠原 監督署で安全衛生の仕事に携わっていたときには、特安・特衛の説明の際にコンサルタント会から担当の方をお呼びして説明をいただいていたのですが、今はどうなってるのかわかりません。

三柴 篠原先生は安全衛生の意識が高い人ですが、他の監督官、すなわち同僚や前後の期の方についてはどのような印象でしょうか。

篠原 安全衛生については総じて高いです。しかし、コンサルタントの活動とは接点がないんです。現場の監督官と、コンサルタント会のコンサルタントの方との接点ですね。これがありません。以前、安衛関係の仕事をしていたときは、建防災の方と交流があつていろいろと情報交換ができましたが、コンサルタント会の方とは情報交流を経験したことはありません。

三柴 監督官の方からすると、感覚的には防災団体の方がコンサルタント会より近い感じでしょうか。もう少し言えば、防災団体の安全管理士や衛生管理士など法令上の資格者に対する認識はいかがでしょうか。

篠原 防災団体とのつながりと言え、よく合同パトロールを監督署で実施しました。かつてはその後で懇親を深める催しがあり、そこで様々な情報交換を行い、そこには当然民間の建設業の方も会員として参加していますので、普段は監督指導等で会話するに過ぎない間柄同士、いい意味での情報交換が行われ、これらは企業の方からの申出もあれば、私どもの方からの申出で行われることもありました。このような話はコンサルタント会となると、少々話が変わってくると思います。

三柴 年齢的には元監督官としては、北岡先生が一番お若いでしょうか。北岡先生、いかがでしょうか。

北岡 私は1995年から2000年まで在職していただけた立場なんです、おそらく私の感覚でいうと、特安・特衛指定をした事業所があると、そこから各種計画を出していただくわけですが、その内容の

水準があまりに低い場合は、おそらく担当監督官が安全衛生コンサルタント制度を教え、いろいろなアドバイスを受けられるからぜひ活用してくださいといったような推奨は、私が在職していた時期には行われていた記憶があります。ただ、現在それがどの程度活用されているかについてはよく分からないところがあり、特安・特衛指定事業所が相応のものを出しているのか、あるいは計画を出す前から角田先生のような優秀なコンサルタントを自身で発掘したためにコンサルタント会には直接コンタクトを取っていないのか、その辺りの感覚は分かりません。

角田 先ほど篠原先生が仰っていましたが、コンサルタントの方で監督署でアルバイトされている方も多く、石綿関係の届出の審査や受理の業務に従事している人もいて、そのような方に安特の仕事がふられたりするという話を聞いたことがあります。そういう意味では、監督署・監督官との距離感ですが、こういう状況であれば特安・特衛の仕事が回ってきやすいという面はあると思います。

三柴 以前、角田先生から安全コンサルタントとしての年収は100万円程度だというお話をうかがったと記憶しているのですが・・・

角田 そのお話はあまりオープンにしないでいただきたいのですが（笑）、私個人ではなく、以前に登録時研修というのがあり、その中で言われたことが印象に残ってしまって、コンサルタント業務としての年収が100万円に達していない人が大半であるとのことでした。コンサルタント業務専門で食べていける人は、それこそ20%もいないのではないのでしょうか。ということなので、それなりに活動している人とそうでない人との格差は非常に大きいと思います。

三柴 逆に、コンサルタントだけで食べていけるレベルの先生はどのようなタイプでしょうか。企業内で雇用されて働いているとか、あるいは独立していても食べていくだけの収入があるとすれば、どのようなスタイルで活動されているとか。

角田 たとえば産業医と兼業をしている人、あるいはISOの審査員をメインにしている人などは省くとして、労働安全衛生コンサルタントだけの人であれば、私が知る限りではもともと企業で安全衛生を担当していたときに顧客を大勢持っていて、独立した際にその顧客をそのまま連れてきたという人が多いです。要するに顧問先をたくさん持っている人が安定した収入を得ています。顧問料は一概には言えませんが、数万円から10万円程度でしょうか。もちろん事業規模にもよりますし、東京が一番高く地方に行くほど月間の顧問料が安くなっていきます。いずれにせよ、顧問先を多く持っている人ほど相応の収入を得ていて、先ほど話に出た登録時研修の際に聞いた話だと、年収2000万円以上の人が数人いるというお話でしたので、相応数の顧客を持っている人はいるのではないかと思います。

三柴 ありがとうございます。他に何かご意見・ご質問は。

北岡 ご報告ありがとうございます。問題のある足場、丸鋸、グラインダーなどなど、1995年から2000年まで労基署に勤務していた頃によく見かける機会がありまして、使用停止命令を出したことな

ども思い出しました。角田先生にお伺いしたいのは、高木先生のご報告とも関連するのですが、最近の中小規模の建設会社の状況がだいぶ変容しているのではないかという問題意識を私も間接的に抱いておりまして、具体的に言えば一人親方が急増しているのではないかということです。ご報告のパワーポイント資料でも、一つのモデルとして元方が協力会社等に対して様々な指導をして安全衛生水準を高めていく・・・私もこれについては全く同感です。しかし、その前提条件が現在崩れつつあるのではないかと、私自身実感ベースで感じております。というのも、協力会社自身が次々に一人親方化させてしまった結果、従業員が実質存在せず、一人親方を束ねている状態に陥っていないかと感じておりました。この点、角田先生からご覧になっていかがでしょうか。

角田 典型例でいうと、左官業の会社でしょうか。範囲自体は非常に少ないのですが、実際に作業している人たちは一人親方を集めてきた形になっています。工事現場などでは作業員名簿ほか作業員に関する様々な情報を出さなければいけないのですが、先ほど高木先生が仰っていたように、隠ぺいされた一人親方も多数見かけます。現場ではハッキリわかっているのですが、書類上では各会社の社員ということになっているという実情もみられます。ただ、現在は建設工事に入るためには社会保険への加入が義務づけられますので、そのようなルールがある種抑止力になりつつ、同時にまた隠ぺいを促してしまっているような一面があると思います。

北岡 社会保険の適用拡大が、むしろ一人親方化をある意味加速化していないかという点について、今懸念しているところですが、その点いかがでしょうか。

角田 加速化しているかどうかはわかりませんが、見えにくくしているという印象は受けます。元請がしっかりしている場合、正直に一人親方の保険手続を行っていることもあります。そうでない工事現場や会社もあると思います。安全パトロールを依頼してくる企業は、そういう正直できちんとした会社ですので、そうでない会社の実情を目の当たりにする機会は少ないのですが、増加している印象は受けます。

北岡 一人親方が増えてしまうことによって、協力会社が安全衛生活動に支障をきたすのか否か、その点はいかがでしょうか。

角田 意思統一というか、指示命令系統に混乱が出ています。たとえば、立入禁止の指示を出し切れなかったりします。私見ですが、一人親方は年配の方が多いので、そういう人に命令するのをつい控えてしまったりとか、あるいは命令しても従わないとか、齟齬が生じているのが少々見受けられます。

北岡 ありがとうございます。

玉泉 私は建設会社の顧問をつとめておりますが、一人親方についての社会保険と雇用保険の加入義務のインパクトが大きく、私の知っている某ハウスメーカーの子会社でも20人のうち半分が労働者でもう半分が一人親方にしている例があります。雇用保険料の額はしれていますが、社会保険料はかなり高くなります。そういう危機感があって、国土交通省が一人親方についての仕様を少々変更するような話もきいて

おりますが、そういう実態への対処かと思われます。もう一つは、今までゼネンコンの安全教育に、下請、一次下請、二次下請の労働者に参加させていたわけですが、一人親方になった関係で参加しなくなりました。そうすると、安全教育が非常におろそかになります。今まで安全教育をやっていた人たちが参加せなくなる、一人親方は事業者ですから必要ないというわけです。そういう事情で、特別教育にも参加しなくなってきました。などということも現実にあります。

三柴 ありがとうございます。もうお一人くらいご意見・ご質問ございませんか。分担研究者の先生方、厚労科研の制度上「研究協力者」に該当する先生も含め、研究を分担していただいている先生方に、現在の経過について一言ずつご報告をいただければと思います。まず北岡先生からお願いします。

北岡 私は罪刑法定主義と安全衛生の確保の関係というテーマをお任せいただいています。これから着手させていただこうと思っています。鎌田先生・田中先生のコンメンタールの記載などは私の分担と関わりが深いと思いますので、その内容もよく拝読した上で検討していきたいと考えております。ご指導の程よろしく願いいたします。

三柴 以前にメールで情報をお伝えさせていただきましたが、玉泉先生はよくご案内ですが、もともと検察官で安衛法の罪刑法定主義について詳しく調査された方がおられますので、ご参照いただければと思います。次に淀川先生、いかがでしょうか。

淀川 現在、第33条と第34条の文献収集中でございます。三柴先生らの報告書を参考に今後検討を進めていこうと思っています。

三柴 承知しました。井村先生、お願いします。

井村 大学の用事が立て込んでいまして、なかなか進捗しておりませんが、一応逐条解説の方は進めております。横断的課題の方はまだ着手しておりませんので、今後は時間が取れると思いますので、なんとか形を取っていききたいと思います。

三柴 ありがとうございます。阿部先生、お願いします。

阿部 私も4月以降、本務校の業務に追われてなかなか進んでおりませんでしたので、8月・9月にかけて逐条解説の方を進めていこうというのが一つ、もう一つは今年度から横断的課題が割り当てられ、作業関連疾患の予防というテーマをいただいていますので、他の先生と協力させていただきながら進めていきたいと思っています。

三柴 ありがとうございます。山本先生、お願いします。

山本 文献収集中でこれから着手いたします。

三柴 承知しました。石崎先生はいかがでしょうか。

石崎 この間、停滞しておりましたが、8月中には作業に戻る予定です。

三柴 承知しました。長谷川先生はご参加いただいたばかりなので、これからということかと思います。平岡先生、お願いします。

平岡 私は土砂崩壊系の法令の成り立ちや生い立ちを調べておりますが、緊急事態宣言が出ていると非常に進捗するのですが、現在は緊急事態宣言の際に書き溜めた状態で止まっています。また進めていきたいと思っています。

三柴 承知しました。佐々木先生、お願いします。

佐々木 私は前回の会合の際にご指摘いただいた事項を踏まえ、各政省令の調査を進めております。また、適用の関係についてはいくつか見えそうな文献を見つけたので、それを参照しながら進めています。それと、角田先生のメールを拝見しまして、私が引用した調査の講評をまとめていただいております。参考にさせていただきます。

三柴 ありがとうございます。佐々木先生が担当されている条文では、衛生規則についても解説で触れる必要があるということになるのですが、別途実務的な観点で藤森先生が衛生規則の趣旨と概要をまとめてくださることになりまして、その点はできる限り情報を共有し合いながら、それぞれ別の観点でまとめていただければと思っています。安全規則については、本日からご参加いただいた浅田先生にまとめていただくこととなります。佐々木先生は、安全規則には踏み込まなかったでしょうか。

佐々木 はい、衛生規則のみです。

三柴 であれば、浅田先生が単独で安全関係の特別規則について、趣旨と概要をまとめていただくというごお願いいたします。次回、浅田先生にはまとめの途中経過についてご報告いただければと思います。それから、原先生、お願いします。

原 私は第20条および第21条を担当しておりますが、三柴先生に個人的にメールでお送りしました「危険のおそれ」という文言を用いている安衛則の条文一覧ですが、藤森先生が作成された資料をもとに拡張させていただきました。藤森先生からは資料の改訂・加筆のお許しをいただきました。安衛則には「危険」という用語は全部で610か所、「おそれ」は三百数十カ所、それをとりあえず一覧にまとめて、横断的検討課題の土台作りをして、また藤森先生がピックアップして下さった逐条解説の条文の大半に「危険のおそれ」という文言が用いられております。なので、横断的課題と並行した形で逐条解説を進めていく予定でございます。



三柴 ありがとうございます。南先生、お願いします。

南 私自身、あまり進んでいないというのが正直なところですが、本務校の夏休みがなくなりましたので、8月下旬まで授業があり、9月中旬の少し前から授業開始となります。夏休みはないのですが、なんとか逐条解説だけはすべて終わらせたいと思っています。まだ日本安全衛生コンサルタント会に関する箇所については、ほとんど手つかずの状態になっていますので、少し深掘りをしていきたいと思っています。できれば分担報告書の締切までには、昨年度執筆した歴史的経緯の部分の踏まえて書いていきたいと思っていますが、少なくとも9月までには各条文の逐条解説は終わらせようと思っていますので、よろしくをお願いします。本日角田先生から労働安全コンサルタントの詳しい業務内容について教えていただいて、本当に勉強になりました。他方、労働安全コンサルタント会はどのような組織なのかについて少し深掘りすべきかと思いました。調べてみると、もともと労働安全コンサルタントというのは、コンサルタントの教育研修やレベルアップのためにあるのですが、現状を見る限りはそれ以上のものを求められていると感じたので、その点も少し勉強させていただきたいと思っています。

三柴 ありがとうございます。内藤先生、先ほどチャットでいただいた件はご指摘の通りで、私の間違いでした。第106条から第108条は予定通りご担当いただくところです。申し訳ありません、資料の記載が間違っておりました。

内藤 ありがとうございます。第106条から第108条については資料収集などを始めております。ただ、7月3日の会合の際も分担案の中に入れておりませんでしたので、私の方から申し上げればよかったのですが、私も見落としておりました。

三柴 いえ、それは私のミスです。申し訳ありませんでした。では、そのまま進めてください。田中先生はいかがでしょう。

（※通信障害のためか音声不明瞭）

田中先生、お声がほとんど聞こえませんので、報告書も提出していただいていますので、次回でも大丈夫なので次回あらためて報告していただくということをお願いします。そうしますと、あらためて横断的検討課題についてご自身の担当をご確認いただきたいということ、そして追加として先ほども申し上げたように、安衛法上の特別規則について趣旨と概要を、衛生関係については藤森先生、安全関係については浅田先生にそれぞれまとめていただくということ、それから機械の本質的安全化について書いていただいた方がいいのではないかというご提案を畠中先生からいただきましたが、浅田先生にお願いしましたでしょうか。

浅田 いえ、まだ伺っていません。三柴先生がご検討されると仰ったように思いますが・・・

三柴 そうでした、了解です。では、これは今一度私が引き取らせていただきます。

これで一応、本日の議題はすべて終了しまして、次回の予定ですが、9月10日の同じ時間になります。

一応、厚労省に会議室をおさえておいていただいておりますが、また Zoom 会議になる可能性が高いです。次回は今のところ藤森先生から衛生関係特別規則の解説を、浅田先生からは安全関係特別規則の解説をいただくこととし、それ以外にもご報告をいただく予定です。その後は、11月21日と12月24日を予定しておりますので、ご参加をお願いいたします。

では、最後に何かメッセージをいただける先生がいらしたらお願いできますでしょうか。せっかくなので、畠中先生、ひと言いただけますか。

畠中 パソコンが不得手なものですから、過去2回ばかり会合を欠席させていただきましたが、今回は何とか教わって楽しく参加させていただきました。証文の出し遅れのように恐縮ですが、冒頭の高木先生のご報告は大変興味深く拝聴させていただきましたが、今までの厚生労働省とその前身の労働省における中小企業対策、特に中小企業の安全衛生対策は検証というものが要らないのだろうかと思いました。要するに中小企業団体をつかまえて、団体の活動としてやっていくということを主体としてやってきたように思いますが、本当にそういうやり方がよかったのかどうか、検証を踏まえたうえでの将来展望が必要であると思いつながりながら聴いておりました。どうもありがとうございました。

三柴 ありがとうございました。では、本日はここまでとさせていただきます。いつもながら、長時間にわたってありがとうございました。非常に有意義なディスカッションをしていただいたと思います。お疲れさまでした。

三柴 本日もお忙しい中ご参集いただきありがとうございます。先にMLで配布させていただいた第13回会議開催要項にそって議事を進めさせていただきます。まず一番目は横断的検討課題の担当者の再調整です。要項でも最後の方で示していますが、これまでに何度もお伝えしました通り、逐条ごとの縦割りの解説とは別に、複数の条文や法令をまたぐ横断的検討課題を設定して論考していただくという企画です。今後の安全衛生法を論じるうえで重要と思われるテーマをピックアップしてきたわけですが、まず作業関連疾患の予防については、阿部理香先生の方から担当が難しいというご連絡をいただいていますので、私が担当しようかと考えています。もう一点阿部未央先生から発注者の責任に関して担当が難しいということでした。確かに法学者のほとんどがそうであるように、阿部未央先生はこれまで安衛法の研究にあまり親しんでこられなかったのですが、発注者の責任の問題は安衛法に詳しい方にとってはいかに重要な課題かということをご承知と思います。しかし安衛法にこれまで接点の少ない方がいきなり取り組むのはなかなか難しい問題です。なので、どなたか適任者がおられれば執筆していただくかと思えます。法学者の方にお任せした方がよろしいかと思うのですが、他方で法学者は安衛法にはあまり詳しくありません。現場の課題であるとともに学際的課題ということもあり、普通の法学的的方法論では捉えきれない面もありますので、法学の世界には安衛法に詳しい方はほとんどいないのが現状です。しかし発注者の責任を法学的に探究することも必要だと思いますので、本来なら法学者に担当していただくのが望ましいのですが、法学者以外の方、たとえば元監督官や技官の方に安衛法政策上あるいは現場論的に問題点を執筆していただくという選択肢もありかと思っています。発注者の責任について執筆して下さる方、どなたか思い浮かびませんか。たとえば建設安全の発注者責任、機械安全であれば機械の本質的安全化、電気であればそもそも回路の組み方、最近であればフリーランスが安全衛生だけではなく労働政策全般の重要課題となっていますが、現在街中で頻繁にみかけるUber Eatsのような言わば疑似労働者についても、発注者やどういう仕事を誰に割り振るかといった業務のシステムを組む業務管理者のような人の責任についても、本プロジェクトで論じるべきでしょう。そういう課題を的確に調べて書いていただける方ということで、どなたか思い浮かばないでしょうか。会合終了後に思い浮かべた方がいらしたら、できれば明日までに私宛にメールか電話でご連絡いただければと思います。

次の課題に移ります。あらためて今年度の調査研究方針の再確認をさせていただきます。法学者を中心に逐条解説をお願いしている先生には、その作業を継続していただきたいということです。特に去年私がコメントを差し上げた先生においては、そのコメントの内容を踏まえて、加筆・修正・削除をください。横断的課題については、去年は森先生のみをお願いしたところですが、本年度は横断的検討課題の担当者には確実に着手していただく必要があります。また、先日藤森先生と個別に相談させていただいたところですが、安全衛生法令の中で特に重要な条文については現場でどういう使われ方をされているか、どういう災害でどういう法令が使われたか、アンケート調査と直にお会いしてのインタビュー調査を予定しています。そこで判明した内容は逐条解説を担当している先生方にフィードバックをする予定です。これまでの安衛法の解説書は、日本語で関係法令を羅列し条文の趣旨くらいは書かれていますが、法令が現場でどう使われているか、どういう災害に適用されているかがみえてきませんでした。ですから、本プロジェクトではリアリズムを追求したいということ、そしてそのことを通じて事務系・文系の人にも安衛法を理解していただくことを狙いとしています。元監督官で安衛法に関心のある方を対象として、アンケート調査と必要な限りでインタビュー調査を実施したいと思います。どの法令が現場ではどのように用いられているのかなどといった情報がまとまったら、先生方に示して解説の中に盛り込んで

いただくということを考えています。この作業においては、藤森・玉泉両先生を含め、行政実務経験者の先生方にご助力いただこうと思っています。

昨年度日本で、企業等の安全衛生関係者を対象に社会調査を実施しました。たとえば経営者で安全衛生に関心を持っているというのであれば、それはなぜか、また具体的にどのような取組みをやっているか、逆に関心がないというのであれば、それはなぜか、といった質問への回答をデータ化したという経緯があります。実はイギリスでも社会調査の業者が存在するということが分かりましたので、イギリスで同様の調査を実施して、日本と比較したいと思います。

すでにこれまでの経過からご承知かと思いますが、本年度は基本的には全メンバーがそれぞれお持ちの知見を披歴していただくことを予定しています。いずれにせよチームで一冊の本を書き上げる狙いで進めていますので、チームワークが非常に重要となります。なので、各自自分の担当の範囲をただ書けばいいというものではなく、情報共有を図り、チームで一冊の体系書を仕上げるという作業を意識してください。したがって、この会議が非常に重要になるため、もし欠席をされたとしても後日必ずZoomの録画記録または議事録のいずれかを確認してフォローしてくださるよう、あらためてお願いいたします。以上が開催要項2の内容です。

次は開催要項3の議事に移ります。分担報告書の執筆要領ですが、毎回ご案内していますように提出期限は早めですが10月末日で、厳守をお願いいたします。現在本プロジェクトには20数名のメンバーが参加していて、全員の原稿に私が目を通したうえでやり取りをしなければなりませんので、どうしても都合上前倒しが必要になってくるということです。またそのやり取りの中で、私がコメントを差し上げますので、それを踏まえて修正をしてください。すでにお届けしていますが分担報告書にはフォーマットがありますので、これに従ってご執筆をお願いします。細かい項目立てについては、初年度の私の分担研究報告書に準拠してください。特に逐条解説についてはそうしてほしいので、逐条解説の担当者の方は私の初年度の分担報告書の項目立てをそのままコピーして、アレンジして使っていただくのが便利ではないかと思います。これもまた再三申し上げているところですが、安衛法を知らない、あるいはあまり馴染みのない文系・事務系の人に読んでもらえるもので、なおかつ深みと広がりのあるものを目指していますので、用語の解説や図表を多用してください。用語の解説については、技術系の人たちにとっては日頃使っている当たり前のもの、たとえば「土止め支保工」の意味とか、そのようなところまできちっとしつこいくらいにまで書いてください。要するに素人がみてもわかり、なおかつ深みも広さもある本を作りたいわけですから。せっかく様々な専門分野の先生が集っていますので、人的資源をフルに活用して、分からないことがあれば技術系の先生方に食欲に質問してください。このプロジェクトのメンバー以外の方に対してもインタビューを実施して下さってけっこうです。その際には、メンバーの先生方に紹介をお願いするのもいい方法かと思います。昨年度に分担研究報告書を提出していただいて、今年度に加筆修正する場合は、細かいところはいいのですが、内容的に変更・追加する箇所については下線を引いてください。逆に、内容が変わるくらいゴツソリと削除する場合には、当該箇所にコメントをつけてください。私がチェックをさせていただく際に、そのようなマーキングがないと、効率が悪くなってしまいますので、お手数ですがこれらの点ご協力をお願いいたします。

事務的な連絡として最後に、横断的検討課題については逐条解説とは報告書を別途あらためて作成してください。逐条解説の報告書と横断的検討課題の報告書と、第一分冊・第二分冊と報告書を分けますので、必ず別々の分担報告書をご提出いただきたいということです。



事務連絡は以上です。それでは、いよいよ研究経過報告に移ります。本日は最初に、畠中先生からご講話をいただきます。ご承知のように畠中先生は、現行安衛法の立法作業に関わられた先生で、そのお立場で今の安衛法がなぜ労働災害を減らせたのかその要因を、そして安衛法制定・施行から50年ほど経過しましたが、今直面する課題と新たな有効策についてお話しいただきたいと思います。畠中先生からお送りいただいたレジュメ（※「現行安衛法はなぜ労災を減らせたのか」、「今後に向けた新たな課題」、以下「畠中資料」とする）を画面共有します。では畠中先生、よろしく願いいたします。

畠中 どうぞよろしく願いいたします。畠中資料のタイトルですが、「現行安衛法はなぜ労災を減らせたのか」、「今後に向けた新たな課題」。これは三柴先生からメールにて、この2点について講話をお願いしたいというご依頼をいただいたのですが、それをそのままタイトルとさせていただいた次第です。

まず、「〔I〕現行安衛法はなぜ労災を減らせたのか」から始めたいと思います。「1 はじめに」とありますが、先ほど三柴先生からもお話がありましたように、1972年（昭和47年）に労働安全衛生法が公布・施行されてから48年が経過しています。この年の6月8日に安衛法が公布され、同じ年の10月1日に施行されています。（注）にありますように、「天の時、地の利、人の和」を得た絶妙のタイミングで成立したということですが、これは安衛法制定当時、労働省の安全衛生部長であられた北川俊夫氏が、後日安全衛生法を語る時にいつも使われていた言葉です。よくよく考えてみますと、昭和47年の翌年である昭和48年は第一次オイルショックの年で、日本経済だけでなく世界経済がメチャクチャになりました。当時、私もボーナスを年に2回どころか、3～4回ももらった記憶がありますが、それくらい物価も急上昇していました。そのような状況で、このような法律をつくっていたとしたら、とても通ったとは考えられません。そういう意味においても、「天の時、地の利、人の和」を得た絶妙のタイミングであったという言葉をしみじみと使っておられた北川元部長の気持ちは、十分理解できるところです。次の（注）に「労働安全衛生法立法の理念」と書きましたが、これは労働安全衛生法施行のための労働事務次官通達（昭和47・9・18発基91号通達）の「趣旨」の末尾に書かれている内容です。安衛法のような大きな法律になると、その施行のための通達も局長通達だけではなく、事務次官通達も出されます。この事務次官通達には基本的なことが書かれます。私のうろ覚えの記憶ですが、確かこれを部長のところに決裁に持っていたときに、この部分は北川部長が書き足した言葉だったと思います・・・「1970年代に入り、従来の経済成長のあり方に反省が加えられ、国の施策の重点は国民福祉の向上へ向けられつつある。このような情勢のもとに、今後における労働災害防止対策は、人命尊重の基本的理念に立ち、この法律を軸として、より強力、よりの確に推進されなければならない。」という部分です。この辺りに北川部長の思いが込められているのではないかと思います。

安衛法をつくろうという機運が最初にかき立てられた出来事といえば、3つ目の（注）に書きましたが、昭和38年11月9日の東西の2つの大事故（※国鉄鶴見駅事故・死者161人および三井三池炭鉱炭塵爆発事故・死者458人）だったのではないかと思います。同日に起きたこの2つの事故が、「生産中心の社会」から「人命尊重」が社会的な底流として定着していく契機となったと言われています。翌年（1964年・昭和39年）には、労働災害防止団体等に関する法律、いわゆる災防法が成立しています。この災防法によって労働災害防止計画が法律上の根拠を持つ計画となり、なおかつ建設業や造船業に対する請負規制が設けられ、さらには労働災害防止団体による自主的な災防活動の基礎がつけられました。そして、昭和41年の旧労働安全衛生規則の改正により、100人以上の事業場について、安全委員会、



衛生委員会の設置が義務化されました。それまでは、安全委員会や衛生委員会の規定はあったのですが、義務規定ではありませんでしたが、この改正によって義務化されました。ほぼ現在の安全衛生委員会制度の基本的な形がこの中に入っております。例えば、過半数組合あるいは過半数労働者代表による議長以外の委員の半数の推薦に関する規定などがそうです。そして、昭和42年8月1日には労働省に安全衛生局が設置されています。しかし翌年の6月15日には、佐藤内閣による一省一局削減政策によって廃止され、当時は“安全衛生局の嬰兒殺し”などということも言われましたが、本当に残念なことでした。

私は1968年（昭和43年）に労働省に採用され、当時の安全衛生局の法規係に配属されました。私が入省した当時、安全衛生局ではそれこそ安全衛生法をつくるんだというムードでいっぱいでした。安全衛生局という局もできたことだし、次は法律をつくるんだ、というムードでした。しかしお話したように、安全衛生局は、私の入省直後に廃止になってしまいました。そのとき、大野さんという人が局長だったのですが、大野局長の退任挨拶の中で非常に印象に残る言葉がありました。要するに、安全衛生行政というものは、“ABC行政”から脱皮を図らなければならないというものでした。ABC行政というのは、頭文字をとってアセチレン（acetylene）、ボイラー（boiler）、クレーン（crane）の検査検定業務だけで手一杯だったということです。ボイラーやクレーンなどの設置がどんどん増えている一方、安全衛生行政を担う人手が追いつきませんので、あっぷあっぷの状況だったんです。まずはそこから脱皮を図らなければいけないということを主張されていました。

そして、1970年（昭和45年）には、労働基準法研究会の中に安全衛生小委員会が設けられ、そこで安全衛生法の具体的な中身が検討され、翌年の昭和46年7月13日に同小委員会の報告があり、それを受けて中央労働基準審議会における審議が始まり、昭和47年の2月4日に中央労働基準審議会の答申がなされ、同月16日に労働安全衛生法案として国会に提出されたという流れになっています。以上は畠中資料の「1 はじめに」の部分であり、いわば序曲ということになります。

次に、「2 労働安全衛生法の制定経過」を簡単に説明いたします。「(1) 労働安全衛生法の立案過程における労使の対応」はどうだったかということですが、経営側はもちろん・・・と言ってはなんですが猛反対でしたが、一方で「労働安全衛生懇話会」というものがつくられまして、昭和46年9月に第1回会合が開かれました。ここでは日経連代表常務理事の桜田武氏、経団連会長の植村甲午郎氏、経済同友会代表幹事の木川田一隆氏といった錚々たる業界のトップが集まり、労働大臣も出席して、3回にわたって懇談会がもたれました。その席における印象的な言葉を一つご紹介しますと、日経連代表常務理事の桜田武氏の言葉ですが、「大正15（1926）年に会社（日清紡）に入ったが、当時の宮嶋清治郎社長は、『人に幸福をもたらさない会社なら潰した方がよい。』と言っていた。40年以上も、この言葉が脳裡に焼き付いている。安全衛生は、職場を預かる者のモラルとしてやらなければいけない。」という発言でした。まさに経営者の良心と誠実さを感じさせる言葉ではないかと思います。出席者一同はこれに大変な感銘を受けたようです。そして、昭和46年12月15日、同懇話会は「労働安全衛生法の制定を要望する。」旨の決議を労働大臣あてに提出したのですが、それ以降、業界からのクレームはぴたりと止んでしまったと、前述の北川部長は書いておられます。

「労働者側の反対」ということですが、なぜ労働側が反対したかという、労働条件のひとつである安全衛生が労働基準法から分離されることによって、労働基準法の労働憲章が適用されなくなるのではないかという懸念によるものです。その点については、中央労働基準審議会の審議段階において、労働基準法には第5章（安全及び衛生）という章名はそのまま残し、その第42条において、「労働者の安全及び

衛生に関しては、労働安全衛生法の定めるところによる。」という文言を規定し、安衛法第1条冒頭に、「労働基準法と相まって」という文言を規定することとされました。当時われわれは、これらを「ドッキング条項」と言い慣わしていました。ということで、労基法と安衛法は一体のものであるということが明らかにされたわけです。そういうところから、労働基準法の労働憲章的部分、特に第1条第2項の労働条件維持向上努力義務や第2条第1項の労働条件労使対等決定原則など、これらは当然、安衛法の施行に当たってもその基本とされなければならない、と事務次官通達に書かれています。「また、労働時間、休日などの一般的労働条件の状態は、労働災害の発生に密接な関連を有することにかんがみ、労働安全衛生法と労働基準法とは、一体的な運用が図られなければならない」ということも、事務次官通達に明らかにされています。

「(2) 国会審議経過」ですが、ずいぶんといいない審議がなされまして、衆議院社会労働委員会における審議が6回、参議院社会労働委員会における審議が4回、それこそ朝から晩までみっちり行われました。われわれ事務方は、前日は先生方からの質問をとって回り、それを国会答弁問答としてとりまとめ、局長までの決裁をとり、取りそろえる作業等々、国会審議の前などは徹夜の作業となりました。そして法規担当の係長は法案審議のときは、大臣の真後ろに座って朝から晩まで必要に応じてメモを差し入れる役割を担っていましたので、前の晩などは完全に徹夜で、次の日は朝から晩までそんな仕事をしていただけです。ということで、6月2日に可決成立し、6月8日に官報公布されましたわけですが、私が国会審議を後ろで聴いていて、最も印象に残っている言葉は、須原昭二委員（社会党）の質問です。「労働者は労災で死んでしまえば生き返ってこないのですよ。したがって、労働者にとっては、安全衛生対策は妥協とか条件のつく交渉ではあり得ない。こういうふうに厳密にとらえなければいけないと私は思う。」ということ仰ったのですが、本当にその通りであると思いながら聴いておりました。

「※」ですが、衆議院社会労働委員会において法案が6項目にわたって修正されています。そのうち大きなポイントはこの2点かと思えます。まず、①労働災害の定義（第2条第1号）が明確にされました。すなわち、「労働者の就業に係る建設物、設備、原材料、ガス、蒸気、粉じん等により、又は」に続く部分が、政府原案では「作業行動によって」であったところ、修正後は「作業行動その他業務に起因して」となりました。法案審議の中で、脳心臓疾患つまり過労死が労災か否かについて議論されましたが、労災に含まれるのであるならばきちんと法文の中に示すべきだということで、「その他業務に起因して」という文言が入ったわけです。政府原案そのものは昭和39年の旧災防法にあった定義を持ってきたもので、そこに安衛法の審議の中で前述の文言が追加されました。もうひとつは、第3条第1項の修正ですが、②事業者の安全衛生上の責務規定です。「事業者は、単にこの法律で定める労働災害防止のための最低基準を守るだけでなく、」という文言の後に、政府原案では「進んで快適な作業環境の実現のために創意工夫をこらすとともに、国が実施する労働災害の防止に関する施策に協力するようにしなければならない。」とされていました。これが修正後には、政府原案の上記下線部分について「快適な作業環境の実現と労働条件の改善を通じて、職場における労働者の安全と健康を確保するようにしなければならない。また、事業者は」と変更されました。事業者の国に対する協力義務が別文章にされたわけです。メインは前段の、事業者は「職場における労働者の安全と健康を確保するようにしなければならない」の部分ですが、第1条の目的規定とまったく同じ文言とされたわけですが、事業者の責務というものは安衛法が目的とする範囲とイコールとなり、非常に広範な責務を負っていることが明らかにされているということです。（※以上につき下記の畠中資料参照）

[畠中資料3頁より]

① 労働災害の定義の明確化

「安衛法2条1号(労働災害の定義) 労働者の就業に係る建設物、設備、原材料、ガス、蒸気、粉じん等により、又は(政府原案:作業行動によって→修正後:作業行動その他業務に起因して)、労働者が負傷し、疾病にかかり、又は死亡することをいう。」

② 事業者の安全衛生上の責務を規定

「安衛法3条(事業者等の責務)①項 事業者は、単にこの法律で定める労働災害防止のための最低基準を守るだけでなく、(政府原案:進んで快適な作業環境の実現のために創意工夫をこらすとともに→修正後:快適な作業環境の実現と労働条件の改善を通じて、職場における労働者の安全と健康を確保するようにしなければならない。また、事業者は)、国が実施する労働災害の防止に関する施策に協力するようしなければならない。」

次は、「(3) 法施行準備過程」ですが、法律は各省折衝や労使団体との折衝が必要となりますので、まとめ上げるのは非常に大変です。国会を通すのももちろん大変です。同時に、国会を通過した後の施行準備も大変です。安衛法は昭和47年6月2日に成立し、6月8日に公布されていますが、施行日が公布の日から起算して6か月以内で政令で定める日とされていました。したがって、施行日は12月1日頃かと思っていましたら、10月1日という話になりまして、そうすると本当に時間がないんです。まず、大蔵省の印刷局に持ち込むのが1か月前でなければなりません。しかも、1頁や2頁ではなく、300頁弱・・・確か280頁ほどだったと思いますが、官報に280頁を掲載するなどという事態は、官報の歴史からみても稀なケースだったと思います。それこそ一冊の本と言っても過言ではありません。これを1か月前までに持っていかなければならないと言われました。畠中資料3頁下の方にも書きましたが、そうすると8月31日が省令、告示の官報原稿大蔵省印刷局持ち込みリミットですから、公付日である6月8日から2か月半しかありませんでした。この2か月半で、労働基準法に基づいて出されているものと同じく、安衛法のための新たな政省令・告示をつくる必要があったわけです。政令をつくる際にも、法案段階で各省との約束事等がありますので、各省折衝のやり直しをしなければならない必要もあります。政令をつくらないと、省令・告示も最終的に固まらないので、まずは政令をつくる必要があります。それと並行して、何千カ条もの数に及ぶ省令・告示をつくらなければなりません。それこそ、土日休みもなしで毎日毎日仕事終わって帰宅できるのが午前2時、3時という状況でした。さらには、施行通達も書かなければなりませんでしたが、なんとか施行日には間に合わせることができました。

「3 労働安全衛生法制定・施行の効果とその背景」ですが、労働災害による死亡者数の推移を拙著「労働安全衛生法のはなし」(令和元年、中央労働災害防止協会刊、中災防ブックス第1版)の9頁に掲載しました。高度経済成長期を通じて毎年6千人前後の方が亡くなっていたわけですが、それが安全衛生法の制定施行の前後に急激な減少がみられ、3千人台にまで減少するのにわずか5年しかかかっていません。畠中資料4頁・3-(1)に各年ごとの減少傾向を掲載しましたが、昭和46年から47年にかけて若干増加していますが、それ以降の昭和48年のデータを見ると362人減り、その次の1年間には939人つまり約1千人も減っています。データを書き出してみても、私自身も驚いたほどです。

では(2)の「産業界に impact を与えた点」とはどういうものだったかについてですが、このことについては、安全衛生部を離れた後も何十年にわたって考え続けてきましたが、簡単に言ってしまえば、結局は畠中資料4頁に書いた数行の内容ではないかと思えます(下記参照)。

(2) 産業界に impact を与えた点



---主たる義務主体の「使用者」から「事業者」への変更(注1)、請負規制やその他の規制の強化(注2)(注3)などを内容とする労働安全衛生に関する独立法の制定という動きを踏まえた、産業界をはじめとする世間の労働安全衛生に対する認識の変化と関心の高まり

・・・これだったのではないかということです。これは数値化して立証するのは不可能ですが、世の中の労働安全衛生や労働者の命や健康を守ろうという思いに、大きな変化があったのではないかということです。要するに世間の「空気」の変化です。結局何十年も考えてきた結論は以上の通りなのですが、この空気の変化について畠中資料4頁に掲載した二人の安全衛生担当者が分かりやすく語ってくれています。安衛法制定・施行10周年を記念して中央労働災害防止協会で行われた座談会の場における、安衛法制定・施行当時の企業(製造業)の安全衛生担当者の述懐をみると、「安全管理体制の形を整えるにしても、その責任者は総括安全衛生管理者ということで、会社のトップでなければならないことになった。したがって、安全への取組みは人道上の問題だけではなく法制面から明確になったので、社内の責任体制も、もう一度見直さなければならぬという、大きな転換点になったと思います。」と製造業の方です。また、建設業の安全衛生担当者の言葉ですが、「(高度成長期を振り返って...)その中で安全はどうかというと、率直に言って、施工第一、安全第二という部分があったといえましょう。」と述べた後、「建設業界では、安衛法の概要を拝見して、うむ、これはいよいよ国も本腰を入れて厳しくやってくるな、という印象を受けました。」と、そのように言っています。これらをみると、まさに世間の空気の変化というものが、大きな変化をもたらしたのではないかと思います。

畠中資料5頁・(注1)に「主たる義務主体の、「使用者」から「事業者」への変更」とありますが、これは基準法研究会報告の中にこういう言葉があり、結論として書かれているところです。すなわち、「安全衛生の確保は、近代的企業経営の前提であり、企業経営者の社会的責任であることを明確にするとともに、企業経営者に、安全衛生の責任ある自主的実践活動を行わせる。」、まさに“企業経営者の社会的責任であることを明確にする”ということです。要するにその下の(注)にも記載したように、労働基準法では、「労基法10条の定義に該当する限りは、時には、末端の係長でも、法律上の義務主体である「使用者」とされる。」ということです。たとえば入善町役場事件(昭和47年2月10日最高裁第2小法廷決定)をみると、町営じん芥焼却場の転落防止措置を怠った結果女性従業員が転落死した事件において、町役場の民生課の衛生係長が、「使用者」とであると判断されています。使用者であると決めつけられたこの衛生係長が、私の上には衛生課長もいるし部長も助役も町長もいるというのに、なぜ私が使用者としての責任を負わされるのかと考えられたのだと思いますが、最高裁まで争ったわけですが、最高裁は結論として、この係長氏を法律上の義務主体である使用者と認めています。国会の質疑応答をみると、なぜ義務主体を使用者から事業者に変えたのかについて何度も審議されているところです。田辺誠委員(社会党)の質問に対する渡邊政府委員(労働省労働基準局長)の答弁が非常に分かりやすいので、畠中資料5頁にも掲載しました。前半の内容は、前述の入善町役場事件を念頭に置いて読むと分かりやすいのですが、「労働関係に関与するいわゆる使用者側の立場にある従業員も使用者の中に入ってくるわけでございます」。そして、「従来ややもいたしますと、最高責任が事業の経営者にあるということがぼける、使用者の範囲が非常に広くて、実際の衝に当たる行為者まで含みますために、最高の責任が経営者にあるのだということがややぼけるきらいもございましたので、今度の労働安全衛生法におきましては、義務を課します対象を事業者といたしまして、---経営者そのものに義務を課しまして、経営者が労働安全衛生につきましては最高の責任を持っておるということを明確にいたしておるところでございます」。このよ

うに明言しています。さらになお書きで、それでは経営者だけが責任を負うのかということ、そうではなく、実際に行為に当たる者も罰則の対象になるのだということ指摘しています。この点の説明について次官通達では、「事業経営の利益の帰属主体そのものを義務主体としてとらえ、その安全衛生上の責任を明確にしたもの」であるとされています。

それから、「(注2) 請負規制の強化」(畠中資料6頁)ということですが、これも労働基準法研究会の結論をみると、「建設業、造船業等構内に多くの下請け企業が混在する産業にあつては、親企業が下請け企業の労働者についても安全衛生管理の責任を有することを明確にする。」ということ。具体的な内容としては、①ジョイント・ベンチャー方式により建設工事が行われる場合の安衛法の適用関係を明確化しています。これは建設業だけです。そして、②一の場合において、請負関係下にある数事業者が混在して事業を行うことから生ずる労働災害を防止するための統轄安全衛生管理体制の確立を求めたということです。旧災防法でも請負規制はメインの一つであり、統括管理者の選任が元方に義務づけられていましたが、旧災防法に基づく統括管理者の選任は、元方事業者が当該場所において講ずべき危害防止措置の一部という位置づけでした。安全衛生法では「統括安全衛生責任者」と名称が変わりまして、これを頂点とした統轄安全衛生管理体制を各現場ごとに構築する仕組みに切り替えたところに違いがあります。統括安全衛生責任者になる人というのは、その場所のトップの人、つまり「その事業の実施を統括管理する者」をもって当てることとされました。旧災防法における統括管理者には、そのような要件は課されていませんでした。それ以外の請負業者は、安全衛生責任者を選任しなければなりません。③元方事業者の指導・指示義務の新設についてですが、造船業や建設業に限らず全産業を対象とするものです。指導・指示義務の内容は、請負関係下にある数事業者が混在して事業を行うことから生ずる労働災害の防止ではありません。安全衛生法令全般に及んできます。安衛法第29条第1項では、「元方事業者は、関係請負人及び関係請負人の労働者が、当該仕事に関し、この法律又はこれに基づく命令の規定に違反しないよう必要な指導を行わなければならない」、第2項では違反を認めた場合は「是正のため必要な指示を行わなければならない」と規定されているように、安全衛生一般に関わる指導義務と違反を認めた場合の指示義務です。そういう意味で、第29条も非常に重要なものだと思います。安衛法第29条は、場所ごとに労働基準監督官を貼りつけるような意味を持っているのではないかと思います。余談かもしれませんが、この条文と趣旨を同じくする規定が、外国人技能実習法の第40条第3項・第4項に置かれています。すなわち、団体管理型技能実習制度において、監理団体「監理責任者」に技能実習実施者に対する労基法、安衛法、最賃法など労働関係法令全般に違反しないよう指導する義務、違反した場合には是正を指示する義務を課しています。

「(注3) その他の規制の強化」ですが、拙稿「労働安全衛生法の形成とその効果」(日本労働研究雑誌475号14頁)に書きましたが、安衛法制定に伴って従来の省令事項が数多く法律事項へ格上げとなっています。たとえば作業環境測定義務は、労基法時代は同法第42条、第43条を根拠として省令に書かれていたことですが、安衛法の制定に際して第65条に規定され法律事項に格上げとなったわけです。これが翌年、昭和48年の作業環境測定法制定の際に幸いました。安衛法上事業者に測定義務があり、その実効性を確保するために作業環境測定法を制定するのだという理屈が立つからです。なお、畠中資料7頁の(注)にあるように、これも書いておくべきかと思って記載しておきましたが、就業資格関係に関して旧労基法では第49条に基づいて5種類もありました。未経験者の就業禁止、技能選考指名、技能講習、講習免許、試験免許です。安衛法では、特別の教育(法59条3項)、技能講習(法61条1項)、免



許（法61条1項）の3種類に分かりやすく整理されています。

以上、「〔I〕「現行安衛法はなぜ労災を減らせたのか」」について幅広い説明をいたしました。安全衛生法のそもそも論から始めましたので、時間が超過して恐縮です。次の「〔II〕「今後に向けた新たな課題」」

（畠中資料8頁）について簡潔に説明したいと思います。「今後に向けた新たな課題」としては多々ありますが、ここでは、三柴先生が提案されておられる「横断的検討課題」の中に取り上げられていない・・・とはいっても最初の機械の包括安全基準については前回報告がなされておりますので「取り上げられていない」と言ったら語弊がありますが、次の2つの項目について取り上げることにします。

まず一番目は「1 機械の包括的な安全基準に関する指針（平成19・7・31基発0731001号）の実効性の確保」です。安衛法はすでに制定当時から※印にあるように、機械等に係る製造・流通規制の思想を体現した立派な条文を設けています。この思想をいかにして具体化するかということが、48年間に及ぶ安衛法の課題であったと思っています。「(1) 背景と機械災害の実態」ということですが、皆さんご存知のことばかりかと思しますので簡潔にお話しますが、EUは1995年以降、機械指令により、機械については、CEマーキングを付したものでなければ域内で流通できないこととなったわけです。日本においても、6年後の2001年には「機械の包括的な安全基準に関する指針（平成13・6・1基発501号）」が出され、それが平成19年に全文改正されたものが現在適用されています。そして、2004年（平成16年）に「今後の労働安全衛生対策のあり方に係る検討会報告」が出されています。この報告を踏まえて翌年の平成17年に労働安全衛生法の大改正がなされ、リスクアセスメントの規定などが創設されています。そのベースとなった検討会報告の結論は畠中資料8頁に書いてある通りです。いわく、「・・・そのために、すでにグローバルスタンダード化している ISO12100 の考え方に則った「機械の包括的な安全基準」の実効性を高めるための仕組みを導入することが必要である。」結論にはそう書いてあるのですが、しかしその後具体化されないまま現在に至っています。厚生労働省が2015年（平成27年）に出したリーフレット「機械安全規格を活用して労働災害を防ぎましょう」によると、機械に起因する災害は、休業4日以上労働災害全体の4分の1、死亡災害の約3分の1を占めており、その原因の8割は機械の安全対策が不十分であったことにより生じているとのこと。そうすると、畠中資料9頁の問題です。「(Q) 2019（平成31、令和元）年の死亡災害845人を念頭に置いて、機械包括安全指針を実効性あるものとした場合、期待される効果はどのようなものであろうか？」考えてみて下さい。

「(2) 実効性を高めるための仕組みの導入」、これは単なるユーザー規制で実施するとすれば、安衛法第20条に基づく危害防止基準として、省令を1カ条追加すればいいだけの話です。しかし、機械の包括安全基準についてはユーザー規制だけでは不十分で、やはりメーカー規制も必要になると思います。（参考）のところですが、ユーザー規制だけで実質的に製造流通規制を実施した前例が旧労基法時代にあります。防爆構造電気機械器具の検定制度ですが、旧労基法第42条の使用者規制だけで行っています。

次に別の問題ですが、「2 「労働安全衛生法施行規則」の新設（現行労働安全衛生規則の整理）による分かりやすさの向上」です。要するに、現行の労働安全衛生規則を施行規則とそれ以外の規則の2つに分割するということです。私は労働基準法は、初等教育を終えた日本国民が、その気になって読めば理解できるものでなければならないと思っています。それと同じく、労働安全衛生関係法令は、現場において作業中の労働者を直接指導または監督する職長クラスの人が、その気になって読めば理解できるものでなければならないと思います。しかし現実には、労基法の労働時間に関する規定など読んですぐに分かる人がいたら教えてほしいくらいですし、安衛法も現実には読めば分かるようになっていません。読め

て理解できれば、実行に移すことができる、あるいは実行に移す気が起きてくる、しかし読んでも分からなければ、どうすればいいのかわからない、そういう話なのです。

「(1) 現行労働安全衛生規則の性格のあいまいさ」ですが、現在の安衛法には、他の法律には通常存在する「施行規則」が存在しません。その理由を問われると少々返答に困るのですが、一応は“歴史的沿革から”というふうに説明されています。旧労基法時代は、労基法の中に含まれていまして、労基法が施行規則を持っていました。労基法第5章の安全衛生関係については、他の規定と異なって2か月遅れて施行されています。本体部分は昭和22年9月1日に施行され、安全衛生関係の部分は11月1日に一本のまとまった規則として施行されております。というような経緯で、安全衛生関係は戦後、施行規則なしでスタートしました。そして、昭和47年の労働安全衛生法に基づく規則をつくる際にも、結局は慣れ親しんだ安全衛生規則に依拠することになりました。なにせ時間に追われていまして、安全衛生部の面々は誰もがあの数か月を死にも狂いで過ごしていましたから、新しいことをする余裕もなかったのでしょう。ということで、安衛法には、危害防止基準を定める規則としては、クレーン則などの特別安全規則が3本と石綿則などの特別衛生規則が11本とで合計14本、これらのほかに危害防止基準を定めるものとして「労働安全衛生規則」がある。しかし労働安全衛生規則は、前記14本の特別安全・衛生規則に規定されている事項以外の事項に係る危害防止基準を定めるとともに、①安全衛生管理体制、②健康の保持増進のための措置、③快適な職場環境の形成、そして④同法の第8章以下の同法施行に係る部分に関する分野で構成されています。そういう意味で、現行労働安全衛生規則は2面性を持っていて、危害防止基準のほか、本来なら独立の施行規則に書かれるべき内容も盛り込まれているわけです。そういうところから、現在の安衛則は、施行規則的要素と、危害防止基準的要素が混在しており、それらは、一応は、第1編「通則」、第2編「安全基準」、第3編「衛生基準」、第4編「特別規制」と編別されているものの、2つの要素が同一の規則の中にまとめられているがゆえの分かりにくさも生み出されている状況にあります。例えば、安衛則の中の危害防止基準を、一つのまとまりとして見ることで各規制事項、たとえば「車両系建設機械」、「フォークリフト」、「発破」などは、“発破安全規則”、“フォークリフト安全規則”、“車両系建設機械安全規則”などと銘打って、いずれも一つの独立の規則にしようと思えばできるようなまとまりがあります。そのような各規制事項を取り出して、特別安全・衛生規則の書き方と対比させてみると、お互いの規定の仕方が違っており、安衛則の方は相当に分かりにくくなっていることが見てとれます。畠中資料10頁に「(具体例) 次の質問に対して、各規則の該当条文を示してお答え下さい。」ということで、予めお時間がありましたら頭のトレーニングをしてくださいとお願いしておいたところです。

(Q1-1) 安衛則第2編（安全基準）第2章（建設機械等）第1節（車両系建設機械）で規制されている「車両系建設機械」とはどのようなものでしょうか？（その定義はどこにあるでしょうか？）

みなさん、いかがでしょうか。これに対して、

(Q1-2) ゴンドラ安全規則で規制されている「ゴンドラ」とはどのようなものでしょうか？（その定義はどこにあるでしょうか？）

という質問ですが、ゴンドラの定義はゴンドラ則第1条にあります。ゴンドラとは何かを知りたければ、「ゴンドラ安全規則」という“ゴンドラ”を題名にした規則をひもとけばいいわけです。これに対して、車両系建設機械つまり車両のついた建設用機械ですが、ある機材が安衛則の車両系建設機械に該当するかどうか知りたい、該当するのであれば法違反がないようにしたい、そう考えて安衛則の車両系

建設機械の該当規定（安衛則第151条の175以下）をひもといても、定義規定がありません。ではどこにあるかということ、安衛則の第94条の2第2号です。労働基準監督署長による工事計画の事前審査の中に、車両系建設機械云々という規定があり、そこで定義されているわけです。つまり、「車両系建設機械（令別表第七に掲げる建設機械で、動力を用い、かつ、不特定の場所に自走できるものをいう。以下同じ。）」とされていますが、この「以下」が第151条の175まで及んでいます。普通に読んでいたらこの定義は見つからないのではないかと思います。実は私もこの定義を見つけることができず、本日出席の浅田先生にご教示いただきました。

次は畠中資料11頁に移りますが、フォークリフトの話です。たとえばある会社がフォークリフトの導入を決定したとして、安全衛生規則をひもとくと、確かに「第二編 安全基準」の目次の中にフォークリフトの項目があるのでそこをひもときました。しかしそこには、特別教育、技能講習、免許など就業資格に関する規定が見当たりません。ということは、無資格者でもフォークリフトを運転していいのでしょうか、というように思ってしまう可能性もあります。そこで畠中資料11頁の(Q2-1)です。

(Q2-1) 安衛則第2編（安全基準）第1章の2（荷役運搬機械等）第1節（車両系荷役運搬機械等）第1款（総則）および第2款（フォークリフト）にはフォークリフトに係る危害防止基準が規定されておりますが、そこには「特別の教育」や「技能講習」に関する規定が見当たりません。ということは、「フォークリフトの運転の業務」に関しては、最大荷重の多寡にかかわらず、「特別の教育」や「技能講習」修了という資格は必要がなく、誰でも運転ができるということなのでしょうか？

また、移動式クレーンはどうでしょうか。

(Q2-2) 「移動式クレーンの運転の業務」に労働者をつかせるときは、何か資格が必要でしょうか？

ある会社でユニック車を導入する場合、移動式クレーンということになりますので、クレーン則第3章の移動式クレーンに関する規定をみればいいわけです。そうすると、そこには特別の教育、技能講習や免許が必要である旨を規定する条文があります。何の問題もなく、パッと分かるようになっています。

次に「(2) 現行労働安全衛生規則の整理と「労働安全衛生法施行規則」の新設」という箇所の説明ですが、現行安衛則の2面性がもたらしている同規則の分かりにくさを解消するため、現行労働安全衛生規則を2分割し、一つは他の14本の特別規則と同様のものとしての、危害防止基準だけの労働安全衛生規則に整理し、もう一つは施行規則として整理するというものです。その場合、14本の特別安全・衛生規則が、その題名を見てそれをひもとけば、当該事項についての規制事項が全て分かるようになっています。たとえば、先ほど例に挙げたユニック車（移動式クレーン）については、クレーン則という題名を見て、なおかつ目次をみて移動式クレーンの項目を開けば、その規制事項が全て分かるようになっています。このように、整理後の危害防止基準だけの労働安全衛生規則においても、まとまりのある各規制事項ごと（例：「車両系建設機械」、「フォークリフト」、「発破」など）に、整理後の労働安全衛生規則の目次を見てその箇所をひもとけば、当該事項に係る規制事項が全て分かるようになっているような規定の仕方をする。車両系建設機械であれば、「車両系建設機械」の項目に定義もあり、特別教育や技能講習など就業資格の規定もあるなど、全ての関連規定がそこにおかれているようにするということです。※印の箇所ですが、整理後の労働安全衛生規則は、現行の14本の特別安全・衛生規則と同列のものとなります。要するに15番目の特別安全・衛生規則になるということです。ただ、中身にゴチャゴチャと色々なものが入っていますので、クレーン則や石綿則などといった特定の題名を付すことはできず、一般的な「労働安全衛生規則」としか付けようがないと思います。そういう意味では、整理後の安衛則は、



目次が他の14本の特別安全・衛生規則の題名と同じ重要なインデックス機能を果たすということになります。現行の安衛則もそうなのですが、目次が非常に重要になります。目次を一覧して、たとえば車両系建設機械の項目を見つけ、そこを開けば車両系建設機械に関わる危害防止基準が全て書かれているようにしたらどうかということです。労働安全衛生法施行規則については、14本の特別安全・衛生規則と整理後の労働安全衛生規則の計15本の危害防止基準全体に共通する事項、例として作業主任者、就業制限、特別の教育などについては、極力、一覧性を確保するように配慮して規定するものとするということです。そのほか、労働安全衛生法施行規則および15本の危害防止基準に係る規則全体に通ずる一般論として、次のような「2度書き」や「条文の引用」や「説明書き」や「念のため規定」の方法を活用すれば、各規則は、大いに読みやすくなってくるとは思いません。たとえば「2度書き」ですが、これは法条文とそれに基づく政・省令によって規制内容が確定するような場合であっても、さらに各規則の中で同様の事項を、言わば2度書きするということです。先ほどから例に挙げているところの、フォークリフトについて配慮が望まれる例(安衛則第151条の16)です。特別の教育でいうと、安衛法第59条第3項とそれに基づく安衛則第36条ですが、両者によって意味内容が確定します。要するにフォークリフトは特別の教育を受けた者でなければ就かせてはならないという意味は確定してしまうのです。だから、安衛則のフォークリフトの項目を見ても、そこには書かれていないのです。だから、法的には正しいことをしていることになります。それに対して、クレーン則の第67条や第68条を見ると、いったん確定しているにもかかわらず、ここでもう一回書いています。このように、大いに2度書きをして、分かりやすく規定してほしいところです。「条文の引用」は、前回藤森委員による産業用ロボットの報告があったところですが、安衛則第36条第31号の定義規定を第150条の3に「本規則36条31号に定める産業用ロボット」といった形で引用すれば、非常にクリアで分かりやすくなります。関係の条文の引用がないことにより、探り当てることに困難を感じている例として、数回前の会合で議論になったところですが、安衛則第518条、第519条の手すりの高さです。墜落による危険防止を狙ったこれらの条文は、非常に重要なものだと思いますが、肝心の手すりの高さに関する定めがないのは不親切です。

(Q) 安衛則 518 条、519 条の作業床や手すりの高さは何cmなければいけないでしょうか？

この辺りは、条文にきちんと定めて分かりやすくするべきでしょう。

「念のため規定」ですが、これは「～のほか」という念のための規定を条文の頭に付けるということです。好事例として労基則第21条、割増賃金の算定基礎から除外される賃金の一覧です。

労働基準法	労働基準法施行規則
第37条 ⑤ 第一項及び前項の割増賃金の基礎となる賃金には、 <u>家族手当、通勤手当</u> その他厚生労働省令で定める賃金は算入しない。	第21条 法第三十七条第五項の規定によつて、 <u>家族手当及び通勤手当</u> のほか、次に掲げる賃金は、同条第一項及び第四項の割増賃金の基礎となる賃金には算入しない。 一 別居手当 二 子女教育手当 三 住宅手当 四 <u>臨時に支払われた賃金</u> 五 一箇月を超える期間ごとに支払われる賃金

労基法第37条第5項には、「家族手当、通勤手当その他厚生労働省令で定める賃金」と書かれていま

すが、法律で既に除外されている家族手当と通勤手当について、厚生労働省令である労基則においてもあらためて書いてくれています。なので、第21条を読めば算定基礎から除外される賃金がすべて分かるようになっていて、非常に親切な書き方をしています。このような「念のため規定」の活用があれば誤解を避けることができたであろう例として、以下の設問をご覧ください。少々引っかけ問題になってしまいましたが、いかがでしょうか。

〔Q〕安衛法28条の2の規定に基づく一般のリスクアセスメントを行うべき業種は、安衛則24条の11②項において次のように規定されておりますが、製造業は、リスクアセスメントの対象からは除外されていると考えてまちがいありませんか？

「安衛則24条の11（危険性又は有害性等の調査）

②項 法第28条の2第1項ただし書きの厚生労働省令で定める業種（注：一般のリスクアセスメントを行うべき業種）は、令第2条第1号に掲げる業種及び同条第2号に掲げる業種（製造業を除く。）とする。」

この規定の下線部分を読んで、うかつな人は、「製造業ではリスクアセスメントをやらなくてもいいのか！」と勘違いしてしまいます。しかし、安衛法第28条の2の中で「製造業その他厚生労働省令で定める業種」と明記されています。法律でいったん書いたからということで、規則で除外しているわけなのですが、これはちょっとどうでしょう（苦笑）。まさに法制局の好きな書き方のようです。

そして「(3) 安衛法制定・施行50周年事業の一環として」です。この「2」の「分かりやすさ」の件については、予想される反論として「今やるべきことなのか?」、「今まで48年間、特段の問題なくやってきたのではないか?」、「もっと緊急に対応すべき問題が別にあるのではないか?」というような不要不急論が出てくることは想像に難くありません。しかし、この問題については、前「1」の機械の包括安全基準のような即効性という面はないとしても、長い目で見ると、安衛法の実効確保という面でボデーブローのように効いてくるという面を有しており、そういう意味では、できるだけ早い時点で、上記のような整理に踏み切るべきものであると思います。タイミング的に言うと、2022年には安衛法制定・施行50周年を迎えることを考えると、その記念事業の一環として、それから先の50年、100年を見据えて、この作業に取り組むことも意義のあることではないだろうか、という結論です。

いただいたお時間を大幅に超過してしまいましたが、ご質問等ございましたらよろしく願いいたします。

三柴 ありがとうございます。ご意見、ご質問等ございましたらよろしく願いいたします。

浅田 大変貴重なご提言ありがとうございました。畠中先生はただ今のご報告の中で二つのご提言をなさいました。そのうちの一つは施行規則の新設ですが、施行される立場にある者が規則の内容を正確に理解して実施するという意味では、大変大きな効果が期待できると思います。それとともに、従来安衛則というものは、安衛法や政令のどの条文の意味を受けたものか、必ずしも明確になっていないものもありますので、通常の施行規則のように、委任を受けた法律・政令の根拠条文を明確化するという機能を持たせてはいかがでしょうか。具体的に言うと、現行安衛則第6条第1項には安全管理者の巡視義務が規定されています。しかし法令上、安全管理者に関する条文は、「事業者は、安全管理者に対し、安全に関する措置をなし得る権限を与えなければならない」などといったように、あくまで事業者を名宛人としています。したがって、第6条第1項のような条文は、義務主体を事業者に変えるなどといったようにす



れば、根拠条文がより明確になるという効果もあるのではないかと思います。また、二点目の機械の包括的な安全基準に関するお話ですが（畠中資料8頁）、法改正をせずに仕組みを導入するという意味では一考に値するご提言であると思いますが、本来は危険源の創出者が責任を負うべきだという観点から、製造流通規制を導入しないとその効果が得られないのではないかと思います。たとえば、こういう形で導入すると、製造者が虚偽の事実に基づいてマーキングを付して、それを知らずにユーザーが使ってしまった場合、メーカーに対して刑事責任を追究する根拠規定がなく、一番悪い奴を処罰することができなくなるという問題も生じると思いますので、その点気になったところです。

畠中 ありがとうございます。

三柴 ありがとうございます。他の先生方からご質問・ご意見などございませんでしょうか。

原 些末な問題で恐縮ですが、一点よろしいでしょうか。畠中資料12頁に「(Q) 安衛則518条、519条の作業床や手すりの高さは何cmなければいけないでしょうか？」という問いがあります。先ほどの畠中先生のご報告にもありましたように、昨年第3回会合にて、私が担当している安衛則第518条・第519条の試作品を報告させていただいた際に、玉泉先生からご指摘をいただきました。当日、お恥ずかしながら私は該当条文に関連のない図式を引用してしまいましたので記憶に残っているのですが、玉泉先生のお話によると、第519条の手すりの高さに関する明確な根拠規定がないということです。このため私が、「手すりの高さに関する決まりがないということは、事業者や事業場によってまちまちということなんですか。各事業場の裁量に委ねるところでしょうか。」という質問をいたしました。これに対して玉泉先生が一応現場では75cmで指導している旨のご教示をいただきました。もしかすると私が失念しているだけなのかもしれませんが、この根拠規定について今一度ご教示いただいてよろしいでしょうか。

三柴 玉泉先生または安衛研の先生方でご存知の方いらしたらお願いいたします。

玉泉 これは通達にあったかもしれませんが・・・明文規定はないんです。判例では、75cmのチェーンが垂れているのが不十分か否かが争点となった事案で、結論として違反になるとした裁判例があったと思います。その事案の中で75cmという数値が出てきたのではないかと思います。

三柴 判例が75センチという具体的な数値を法創造的に設定するというのは考えにくいので、おそらく参考資料になるものがあったのではないかと思います。

玉泉 高さ75cmくらいのチェーンが垂れていて・・・

三柴 ……なるほど、具体例に即した判断がなされたということでしょうか。

玉泉 そうです。そういう事案だったと思います。今すぐには見つからないのですが、昔から75cmだ

ったと思いますが、根拠規定を調べてみましょう。

原 ありがとうございます。お手数おかけします。

三柴 ありがとうございます。他にいかがでしょうか。

北岡 畠中先生、ご報告ありがとうございます。以前からお伺いしたい点がございまして、現職時代から感じておりましたが、安衛法第29条の元方規制について罰則規定が設けられていません。これは一体なぜなのでしょう。建設業については、発注者に対して非常に厳しい罰則規定がある一方で、第29条には罰則がありません。監督官として現場指導している際に、必ず参照していた記憶があるのですが、この点立法当時の議論状況をお伺いできればと思います。よろしくお願ひします。

畠中 安衛法第29条を読むとお分かりになるかと思いますが、やはり構成要件が広すぎてハッキリしないところがあります。そういう意味で罰則のつけようがないんです。

三柴 やはり直接の使用者でないという点が問題だったということでしょうか。

畠中 その点については議論の中ではあまり問題にならなかったように思います。要するに構成要件が明確でないというのが一番の問題でした。

三柴 逆に言うと、たとえばリスクアセスメントの化学物質のように、今からでも対象を明確にして構成要件を具体化すれば、罰則をつけることも可能でしょうか。

畠中 そうですね。やり方としては例えば、労働基準監督署長の措置命令権を条文の後ろにつけて、命令違反に対して罰則をつけることは可能だと思います。

三柴 そうなると、具体化のプロセスさえ規定しておけば、罰則規定をつけられる可能性もあるということですね。

畠中 その通りです。とはいえ、もし罰則がついたら大変な規定になります（笑）。

三柴 確かにそうですね。運用も大変そうですね。

北岡 ただ、工場法を振り返ると、もともと構成はそうなっているんですね。というのも、工場法では当時の内務省が事業者に対して命令権限を持ち、事業者がこれに従わなかった場合に罰則を適用するという構造になっていました。それが労基法制定の際に、具体的に構成要件を定めていこうということになったので、安衛法第29条についても、もしかするとそういう発展の仕方を経ているのかと、今のお話をうかがっていて思いました。もう少し大きな話として、罰則規定を設けるか設けないかについて、立法

過程で何か議論があったのでしょうか。その点ご教示いただければと思います。

畠中 罰則に関しては特段議論はなく、すんなりと通った記憶があります。

北岡 第29条に限らず、各条文ごとでは議論の様子はいかがでしたでしょうか。

畠中 それほど議論なしに通りました。最終的には法務省との協議も経ていますが、そこでもすんなりと通りまして・・・

北岡 基本的には危害防止基準については旧労基法の中でも罰則が設けられていましたので、安全衛生法施行規則においても、そのような問題はなかったのでしょうか。

畠中 全く問題ありませんでした。少なくとも第20条から第27条の危害防止基準には、罰則は当然つくものだと考えられていました。

北岡 新設された第29条については、かなり包括的な規定だったので、罰則規定には二の足を踏んだということでしょうか。

畠中 そういうことです。

北岡 ありがとうございます。

畠中 もう一点、監督官としての実務経験のある北岡さんにお尋ねしたいのですが、安全衛生法の施行規則は有用かつ必要でしょうか。

北岡 そうですね、やはり昭和47年に比べて活用される規定はだいぶ変わってきていると思います。フォークリフトについては、昭和47年当時に比べると現在多くの事業場で使われていますので、そういう意味では重要な規定は安衛法とは別立てで明確に規定することは非常に有益なことであると感じました。

畠中 ありがとうございます。

三柴 今の畠中先生のご質問は、特別規則の通則みたいなもの、それと新しく出てきたリスク要因に対する特別規則の追加のようなものと、両方のお話だったと思いますが、その両方について北岡さんのご意見はどうでしょうか。特に前者の問いについてはいかがでしょうか。

北岡 もう一つ、安全衛生施行令があり、これと規則とが宙ぶらりんになっているところがあると思います。立法技術的には労働安全衛生法に「施行令に委ねる」旨書いてある部分は施行令に書かれ、それ以

外のものも施行規則に、というようになっていると思います。確かに監督官も事業者も使い勝手が悪いことは事実だと思います。その意味では、両者の間に通則的なものがあれば一定の有用性はあるのではないのでしょうか。

三柴 先ほどの浅田先生のご指摘にもからみませんが、施行令は定義規定のようなもので、規則全体にまたがるような通則を定めたものがあって、あとはリスク要因に応じて特別規則が整備されている状況であれば分かりやすいですね。しかし、制定するときのいろいろな事情もあって、なかなかそのようにすっきりとした整理ができなかったというのも理解できます。他にどなたか、ご意見、ご質問などよろしいでしょうか。

吉川 先ほどの原さんのご質問ですが、私も調べてみました。安衛則に架設通路の規定がありますが、第552条第1項第4号に「墜落の危険のある箇所には、次に掲げる設備・・・を設けること」とされ、同号イに「高さ八十五センチメートル以上の手すり又はこれと同等以上の機能を有する設備（以下「手すり等」という。）」という文言があります。ここに高さの規定があるかと思われそうですが、いかがでしょうか。私も安衛則や手すりに関する規定の全容が把握できていないので、正解か否か分からないのですが。

原 ありがとうございます。

三柴 この規定がある以上、危害防止基準とみていいのでしょうか。具体的にこのようにするべきと定めているという理解でいいのでしょうか。

原 そうですね。この規定にいう「墜落の危険のある箇所」とは、足場に限らずおよそ墜落の危険がある場所はすべて、という意味ですね。

吉川 架設通路において、です。

玉泉 この条文は先般改訂されまして、従前は75cmでした。足場の規定である第563条との関連で、ここで85cmと定めたものです。もともとは75cmでした。第518条、第519条は作業床に関する規定なのに対し、第552条は通路なので趣旨は少々異なりますが、以前は確かに75センチでした。これが、平成21年に第563条等の足場の基準が変わり（<https://www.mhlw.go.jp/bunya/roudoukijun/anzeneisei26/dl/01.pdf>）、それとあわせて変更されたもので、結果75cmから85cmに変わりました。本当は90cmに定めたかったようです。安全衛生研究所によるシミュレーションと実験では、90cmが最も妥当という結論で、改訂の際にも90cmにしたかったようですが、すでに市場に出回っている手すりが85cmだったために、基準を90cmに定めてしまうと日本中の足場を全て交換しなければならなくなります。そういう事情もあって、85cmに定めたというようにうかがっております。

原 85cmと90cm、その5センチの差は、許容すべきリスクということでしょうか。

玉泉 昭和50年代の初めころに、手すりの高さについて、75cm、80cm、85cm、90cm、95cmそれぞれの高さで、人が当たって乗り越えるリスクが調査されましたが、90cmであれば95%の人が乗り越える危険はないという趣旨の報告書が安研から出されています。それが念頭にあったのではないかと思います。

三柴 素人っぽい質問になりますが、私の理解では、手すりをより安全にするためには、本数を増やすというのが基本で、あとどこに設置するかという高さ調整の話になると思うのですが、高さといった場合には高ければいいというものではないし、さりとて低ければいいというものでもありません。

玉泉 そのために改正によって、「中さん」が必要になったわけです。従前は、85cmであれ90cmであれ、中さんの規定がありませんでした。75cmの場合は、しゃがんだりしない限り大丈夫だったのですが、85cmにすると手すりの下の部分から墜落する可能性があるので、中さんの設置を義務づけることになりました。

三柴 法律家の頭では、労基法や安衛法においては、最低基準を定めたうえで、それよりも条件のいい基準を実施するのであれば各事業者がぜひやってくれという構造になっています。手すりの問題については、基準が85cmに設定されているとすると、それより条件のいい高さの手すりとなると、どのように理解すべきでしょうか。

玉泉 高さについては、85cmよりも高い方がいいと言われていますが、1mや1m20cmになると隙間が空きます。下の部分からの転落についても考慮しなければならないので、高さがどこまで許され、また高さの最低基準が何センチであるかなどとは、何とも言えません。建築基準法では、高さが1m10cmで、縦にスリットを入れて子供の頭が通らない程度の11cmだったと思いますが、隙間の幅をそれ以下にしなければいけないなどと細かい規則があったと思います。労働安全衛生法では、足場などについてはさほど細かく規制はできませんので、若干アバウトになっているわけです。85cmから90cm程度で大体やっているのではないかと思います。今の規格は、概ね85cmでやっていますので、それを超えて90cmや1mの手すりを設置することは、現実問題としてあまり見受けられないと思います。高い方がいいというのは確かですが、そうすると下からすり抜けて転落する危険がありますので、その点を考えなければなりません。

三柴 ありがとうございます。それでは少々休憩を入れさせていただきます。



三柴 再開させていただきます。後半の冒頭では開催要項には記載しませんでした。森先生が化学物質管理について横断的な報告書をご執筆のところ、だいぶ出来てきたということでこれについて簡潔にご報告いただきたいと思います。ざっと拝見したところ、専門家内外に対して頭の整理にもなり新しい知見も踏まえていて、非常に示唆的な内容とお見受けしております。森先生、早速ですがよろしくお願いいたします。

森 まだ執筆途中ですが書き進めていると54頁にもなってしまう、さらに頁数が増えそうなので、この辺りでいったん簡潔に概要を報告させていただくということで、お付き合いいただければと思います。

今回、化学物質の中で特に健康障害に特化し、その規制の現状や労働衛生上の知見などをまとめるという流れになっています。「労働安全衛生法令に基づく化学物質による健康障害防止対策の現状と課題」（以下「森資料」とする）の冒頭に「Ⅰ 化学物質による健康障害の発生と管理の原則」という形で、いわゆる三管理を基盤に説明をし、そのうえで、化学物質には非常に多くの種類があるのでそれらがどのように管理されているのかについて、法令上の一般規定のあとに規制対象物質の分類という形で記載しています。その中に「裾切り値」の話が出ていますが、これは対象物質の話ではありませんが、混合物質について含有率がどの程度であれば当該物質として規制対象とするかという話で、これも森資料Ⅱ・2・(5)で解説しています。それに次いで「3. 化学物質管理のための体制」ということで、指針レベルの話も含め記述しました。さらに、化学物質による健康障害防止をどのように進めていくのかということ森資料Ⅲに書き、「1. 化学物質の健康障害防止戦略の前提」とありますが、要はリスクアセスメントを前提としています。リスクアセスメントは有害性の評価と曝露評価を行い、モニタリングしたものを許容濃度等の指標と比較してリスクを見積もっていく流れを書いています。そしてリスクを許容できない場合の化学物質のリスクコントロールの流れを書き、最後に労働者への周知や労働者の知る権利などの話にも触れ、労働安全衛生マネジメントシステムで管理していくべきである旨書いてます。最後に付け足しになりますが、特別規則による管理ということで、有害物に関しては4つの特別規則について大体どのような規制内容になっているか、他の箇所と重複するかもしれませんが記述しておきました。以上のような骨格になっています。

森資料の「はじめに」は割愛しまして、「Ⅰ 化学物質による健康障害の発生と管理の原則」ということですが、基本として「図 化学物質による健康障害の発生と対策」（森資料4頁）を掲載しました。要は有害物発生源から実際に健康への影響が生じるまでのプロセスです。曝露の前までが作業環境管理で、その後のプロセスにおいては作業管理と健康管理が続きます。それぞれどこを中心にモニタリングするのかということですが、作業環境測定があり、個人曝露測定があり、生物学的モニタリングがあり、さらにそれぞれの測定結果を比較する指標として、管理濃度、許容濃度、生物学的曝露指標というものがあります。さらに図の下にはコントロール手法として根源から断つという原則が重要である旨を、本文とあわせて記載しました。ISO 45001でもこれが求められる形になっています。

こういう全体像のもとに、具体的にどのような規制があるのかということについて書いたのが、「Ⅱ・1. 事業者の講ずべき措置等の一般規定」で、安衛法第22条によって事業者に課せられた原材料、ガス、蒸気、粉じん等による健康障害防止のための措置および特別規則の概要について書いています。次に規制対象物質とはどのような物質かということですが、まず全体像を示すために「(1) GHSの危険有害性を利用した化学物質等安全性データシート(SDS) 交付対象物質」について記述し、その上で安衛法第5

7条の2および安衛則第24条の15にて、危険有害性のある化学物質全体が努力義務とはいえ規制対象になっているという広がりがあり、これだけ多くの化学物質がある中でどのようにして具体的内容に関する規制がなされているかという話を次に示しています。「(2) 法令、特別規則による規制物質」では、製造等禁止物質から始まり、それ以外の物質についても説明しています。最近しばしば議論の対象となるのは、「(3) 主に発がん性に着目した分類」で、安衛法第28条第3項に基づいて公表された「がん原性指針」に列挙された物質を記載しました。このような物質を指針や通達レベルで規制するほか、「(4) 新規化学物質」、つまり新しく出てきた化学物質についてどのような対応をしているか、法令の根拠条文や流れ図をここに書いています。化学物質、特に有機溶剤の多くは混合剤なので、法的規制を施す場合の基準が必要になってきます。SDSの中では「裾切値」（当該物質の含有量(重量%)がその値以上の場合にはそれぞれの規制対象となる）という形で、ここに記載した数値が定められています。同じような規定が特化則や有機則にもあります。さらに、特化則での規制対象は毎年のように見直しがなされていまして、最近特に頻繁に行われていますが、その手続きについて「化学物質のリスク評価に係る企画検討会」以下様々な検討会が手を踏んで、実際にリスクアセスメントを行い、規制対象を決定しています。最近特化則の規制対象となった物質は森資料14頁に掲載しています。

以上、規制対象となる物質について整理したわけですが、このような物質を現場ではどのような体制で管理し、どのような人材がいるのかということを書いたのが、「3. 化学物質管理のための体制」（森資料14頁）です。衛生管理者、産業医、作業主任者、また化学物質のリスクアセスメントの指針では「化学物質管理者」に関する規定もあるので、これらを幅広く整理して記載しました。現状においては、欧米ではインダストリアルハイジニストやオキュペイショナルハイジニストと呼ばれる有害要因管理にかかる専門家がいるのに対し、日本では日本産業環境測定士協会が認定オキュペイショナルハイジニストの育成を行っていますが、人数的に未だ少なく自主管理の展開の大きな課題となっているという内容です。次に「Ⅲ 化学物質による健康障害防止の戦略」ですが、まず「1. 化学物質の健康障害防止戦略の前提」ということで、まず労働者が曝露するレベルを許容レベル以下にするという基本があります。しかし、リスク低減が許容レベルにまで図られたとしても、リスクアセスメントでは見逃した曝露があったり、たとえば妊娠中の女性のように特別な健康状態の人もいるので、そのような人たちには別個に特別な対応を行い、全体として健康障害を防止しようとするものです。まず最初に着手するのが化学物質のリスクアセスメントということで、リスクアセスメントの義務化の話から始まり、化学物質以外のリスクアセスメントについても安衛則上努力義務規定があり、その具体的な方法は、「化学物質等による危険性又は有害性等の調査等に関する指針」に規定されている旨説明しています（※「2. 化学物質のリスクアセスメント」、「(1) リスクアセスメントの義務化」（森資料19頁））。指針の内容は、通常行われる定期的なリスクアセスメントではなく、変更の際の管理を求めているものですが、問題点として化学物質のリスクアセスメントが義務化された際に、法令上は変更の管理のみを求めているので既存の化学物質については実施しなくてもいい旨の指導がなされ、実際に網羅的なリスクアセスメントを実施しなかった事業者が存在していたという事案があったという話にも触れています。リスクアセスメントの実施に際しては、有害性情報がなければなりません。「(2) 有害性情報」（森資料21頁）では冒頭部分と重複になりますが、GHSの話を書いています。GHSは現行法にも反映されているので十分留意する必要があります。次に、化学物質の関しては労働者の曝露を推定しなければなりません。曝露推定の方法は、個人のリスクアセスメントでは本来は個人曝露測定と許容濃度等の比較が基本になります。許容濃度等に関

しては、アメリカのACGIHやドイツのDFGほか、アメリカの場合OSHAがPELを出しています。実際に許容濃度がどのように決められているのかについても、簡潔に説明しました。作業環境測定の場合は管理濃度が問題となりますが、管理濃度は定期的に見なおしが行なわれているもので、最近ではどのような見直しが行なわれているかについても記述しています。生物学的モニタリングの場合には、生物学的曝露指標が対象になるので、説明を加えておきました。日本の場合、法令上生物学的モニタリングで尿中代謝物の測定をするときに、一部の物質について「分布1～3」の値が設定されていますが、この場合尿中代謝物はBEIではクレアチニン補正が基本になっています。しかし日本ではクレアチニン補正ではなく、下がりットルになっていることに注意が必要であることも記載しています。さらに、法定の基準に基づいて曝露値を測る作業環境測定について、森資料25頁以下で法令の規定内容を詳しく書いています。ここでは、最近法改正が行なされた個人サンプラーについても触れています。

次が個人曝露測定に関する記述です（森資料27頁）。日本産業衛生学会産業衛生技術部会のガイドラインがありますので、これを中心にそれ以外の情報もあわせて簡潔に記載しました。生物学的モニタリング（森資料28頁）については、法令で規制されている物質、特に特化則では二次健診の中の医師が認める項目がありますので、これを一覧表にまとめました。こうした曝露推定値と化学物質の有害性に基づいてリスクの見積りを行うこととなりますが、31頁でどうやってその見積りを行うかについての指針を掲載しました。実際に測定する場合には、有害性のレベルをA、B、C、D、E、Sに分類し、曝露の程度を許容濃度と比較して推定することとなります。ただ、実際に測定してリスクアセスメントを実施するのは難しいので、「コントロール・バンディング法」のような簡易な方法も開発されているという話も書いています。

「3. 化学物質のリスクコントロール」（森資料37頁）では、対応すべき措置として「1 除去すること」から「5 個人保護具」までの優先順位を示し、「(1) 発散の抑制」、「(2) 個人用保護具」「(3) 特殊健康診断・健康管理手帳」の各項目では、各論を書く予定です。「(4) 特別な健康状態（母性保護規定を中心に）」として、母性保護規定を中心に特別な健康状態にある人には化学物質曝露からの法的保護があり、それ以外の健康状態の人についても何らかの個別的対応をしなければならないことになっています。森資料38頁の女性労働基準規則第二条は、女性を就労させてはいけない業務に関する規定です。

さらに、「(5) 労働者への周知および知る権利」ということで、どのような化学物質を使用しているかについて表示することを義務づけています。また、作業環境測定の結果についても労働者に知る権利があるので、通知が義務づけられています。そのようなリスクマネジメントを行ううえで、労働安全衛生マネジメントシステムが非常に有効で、安衛則の中では「4. 労働安全衛生マネジメントシステム」（森資料42頁）に記載したような位置付けになっていて、ISO45001に関わる内容もまとめています。

「IV. 特別規則による管理」（森資料44頁以下）では、まず「1. 定化学物質障害予防規則」において特化則においてはどのような規制対象物質があり、そのような内容の規制が行なわれているかを述べ、次いで「2. 鉛中毒予防規則」、「3. 四アルキル鉛中毒予防規則」、「4. 有機溶剤中毒予防規則」においても同様の内容が出てくる旨述べています。

以上のような内容でまとめているという中間報告となりましたが、後日またメール等でご意見・ご質問いただけると幸いです。若干駆け足となりましたが、以上です。

三柴 ありがとうございました。森先生はご都合により間もなく退出されますが、統括者として一言申



し上げると、やはりどうしても丁寧な説明を心がけていただくと、文章が多くなってしまふことがあります。読者に概念理解をもたらすために、冒頭に挙げていただいたような図式によって、各知識ごとの関係性を明確にすることと、それらが概念的に、そしてイメージ的に理解するための手助けとなるような書き方をあらためて意識していただけると幸いです。大変ていねいな解説を行っていただき、ありがとうございます。

森 ぜひそうさせていただきます。健康診断についての拙稿は、もう一度自分なりに図を入れたりする作業などを試みていますが、化学物質についても書き上げる際にイメージを分かりやすくする図を入れていきたいと思います。

三柴 開催要項からするとイレギュラーな形で森先生にご報告をいただきましたが、要項の手順に戻しますと、予定としては浅田先生、藤森先生、そして私からの報告ということになりますが、浅田先生は時間の都合上資料の作成にまで至らなかったということですので、現状と今後の予定について口頭でお話しいただければと思います。

浅田 本日は資料が間に合わず大変失礼いたしました。本プロジェクトの過去の資料等を読みこなしながら、皆さんに追いつくための作業を行ったり、あるいは私が担当させていただく特別安全規則に関係する資料の収集などに務めてまいりました。イメージを申し上げますと、まず第一に検討対象となる特別規則はボイラー則、クレーン則、ゴンドラ則の3つになります。二点目として制定等の経緯ですが、ボイラー則については戦前の汽罐取締令、労働基準法制定時の労働安全衛生規則における特別安全基準、それが旧ボイラー則として独立し、その後安衛法が制定された際に現行のボイラー則に移行となりました。クレーン則については、戦前の歴史までは追い切れていないのですが、労働基準法の特別安全基準の中に含まれていたものが、旧クレーン則として独立し、その後安衛法制定に伴って現行のクレーン則に移行しました。ゴンドラ則は労働基準法時代に旧ゴンドラ則が制定され、その後安衛法の制定に伴い新ゴンドラ則に移行しました。安衛法の中で最も厳しい規制を受けている特定機械等については、製造に始まり設置、使用、変更、休止、廃止に至るまでの一貫した規制が定められています。その中には、人的規制としての就業制限や特別教育も含まれています。最後に問題提起というか、私から見た現行の規則について提案してみようと思う点があります。ゴンドラ則はクレーン則から独立した規則となっておりますが、規制内容からするとクレーン則の中のひとつと考えても問題はないと思われまふ。ただし、ゴンドラには大きく分けて常設型と可搬型の2種類があり、高層ビルなどに設置されていて、いったん設置すれば動かない常設型、そして小型軽量の可搬型です。常設型については製造許可の後に設置届、落成検査、といったようにクレーンと同じような規制にすべきではないかということです。他方、可搬型については現行のゴンドラ則と同じように、製造許可と設置報告を義務づける。このような形で二つに分けた方が合理的で、なおかつ安全確保も図れるのではないかと思います。というのも、常設型については設置する際の安全確保がその後の安全を図る上でも極めて重要な位置付けを持つからです。

三点目ですが、クレーン則においてはデリックの規制があり、人的規制たる免許制についてはクレーンとデリックが統合されましたが、物的規制に関しては別になされています。うち、デリックの設置数が極めて少なくなっていますので、これをクレーンの中に盛り込むというのもひとつの手法かと思ひます。

四点目として、エレベーターのうち工場や倉庫に設置されるものについては、検査も含め労働安全衛生法の規制を受けています。それ以外の一般公衆のためのものは、建築基準法の規制を受けています。そうすると、物的基準についても、より制度化を図ったほうがいいのではないかと思います。また、細かい話ですが、落成検査や性能検査など検査を実施したとき、検査証の裏書をするのが実務です。しかし、この裏書の根拠条文が存在するものとしがないものがあるので、この点についても実務に合わせて整合化を図ってはどうかと考えています。

現時点で思い付いているのは以上の通りです。

三柴 ありがとうございます。時間の関係もありますので、次に藤森先生からご報告をいただきたいと思います。資料として「労働衛生関係の特別規則の趣旨と概要、統合の可能性について(骨子案)」(以下「藤森資料」とする)をお送りいただいています。

藤森 前回の報告では産業用ロボットについて触れ、今回は労働衛生関係規則について藤森資料にまとめさせていただきましたが、途中経過の報告ということでご了承いただきたいと思います。藤森資料1頁目に11の労働衛生関係の特別規則を列挙しました。もっとも古いものは電離放射線障害防止規則です。時期をみると昭和47年、つまり安衛法ができた年に労働省令として制定されたものですが、その前の時代に前身となる規則があり、たとえば電離放射線障害防止規則は昭和34年に制定されています。その辺りの経緯ほか、安衛法上の規則としてどのように衣替えがなされたかといった点も検討できればと思います。

藤森資料1頁には「2 主要な論点」として、アプローチすべき項目を書き出しました。「(1) 各規則制定の背景・経緯及びその後の主な改正点」では、社会の醸成を踏まえてどのように変わってきたかをコメントできればと思っています。「(2) 労働安全衛生法及び労働安全衛生規則(昭和47・9・30労働省令32号)との関係」ですが、安衛法と11の規則との縦と横の関連性に触れるつもりです。「(3) 各規則の基本構造・体系の共通性等」、ここでは法令から見た共通点、相違点というか対比ですね、「三管理」を軸にコメントできればと思います。「(4) 定義・範囲」はそれぞれの法律に範囲・定義があり、それが衛生関係においては措置を講ずべき対象として定められています。その辺りを言及しようと思います。そして次に「(5) 適用の対象、適用の除外・特例・例外等」ですが、有機則など規則によっては様々な局面で、いかなる基準に基づいて適用除外、特例、例外などが設けられているのかについて言及します。

その下の箇所、藤森資料1頁の「1 各規則制定の背景・経緯及びその後の主な改正点」今述べた通りですが、次の「2 労働安全衛生法及び労働安全衛生規則との関係」で、縦と横の関係です。安衛法でいうと第22条の健康障害防止措置に関する規定で、これを具体化した安衛則の規定との関係です。今悩んでおりますのはヨコの関係話で、安衛則でいうと「第3編 衛生基準」と特別規則とがどういう関係にあるのかということに言及できればと思います。いわゆる特別法と一般法(特別規則と一般規則)の関係なのか。あるいは作業関連疾患の問題、直接的な規制のない騒音や振動の問題。騒音や粉じんについては安衛則にも規定があり、粉じん則もあるわけですが、その辺りどう棲み分けがなされているのかについても説明できればと思います。近時は安衛則は、第3編の中でダイオキシンの規定を設けていますが、なぜこの箇所で規定せざるを得なかったのか、その辺も検証したいと思います。

藤森資料2頁「3 各規則の基本構造・体系の共通性等～労働衛生の「3管理」を中心として条文を解



説」においては、三管理、同頁の（1）作業環境管理、（2）作業管理、（3）健康管理のことですが、それぞれの場面で各規則に条文が設けられています。これらには最大公約数という共通点があるということも含め、検証していきたいと思います。「（4）管理」は全体の管理の問題で、たとえば作業主任者や教育の問題・・・作業主任者は有機則や酸欠則にも規定がありますが、それ以外の規則とのバランスを考えると、なぜ特定の規則の中にしか規定がないのか、この点もお尋ねしたり検証したりしながら言及していければと思います。教育についても、安全の場合は安全衛生特別教育という形で一般化されていますが、衛生関係の場合はそれぞれの規則において別個に規定されています。そのような規制内容に至った経緯についても言及するつもりです。

「4 定義・範囲」ですが、規制対象や講ずべき措置の対象は、それぞれの規則ごとに異なっています。有機則であれば、有機溶剤の含有率が何%とか、鉛の合金であれば鉛以外の含有が10%とか、その辺りの根拠については森先生にお任せするとして、どのような規制の仕方でどういう仕組みになっているのか、言及するつもりです。

「5 適用の対象、適用の除外・特例・例外等」、これは藤森資料にも①～⑥まで記載しましたが、①有機則のように適用対象を業務として捉えているもの、②鉛則のように作業として捉えているもの、また有機則は同時に③物質として適用対象を定めているもの、④酸欠則や粉じん則のように場所を対象とするもの、そのほか⑤時間や⑥使用量など、法令上どのように規定されているのかという問題です。

最後になりますが、藤森資料のタイトルが「労働衛生関係の特別規則の趣旨と概要、統合の可能性について」と、“統合の可能性”を示唆していますが、その言葉通り統合ができるのかどうか難しいところもあります。他方、畠中先生もご指摘の通り、分かり易さや簡便性を重んじるのであれば統合も選択肢の一つとして検討に値するのではないかと思います。

以上です。

三柴 ありがとうございます。私の方から申し上げますと、浅田先生のご担当が安全、藤森先生のご担当が衛生という区分けをさせていただいています。藤森先生が藤森資料で示してくださった「2 労働安全衛生法及び労働安全衛生規則との関係」の部分については、浅田先生にとっても参考になると思うので、なるべく平仄を意識すべき点を意識していただきたいと思います。藤森資料でいうと、以下の部分です。

〔※藤森資料より抜粋〕

## 2 労働安全衛生法及び労働安全衛生規則との関係

### （1）労働安全衛生法との関係

第4章「労働者の危険又は健康障害を防止するための措置」

第7章「健康の保持増進のための措置」

### （2）労働安全衛生規則との関係

第3編「衛生基準」との関係

- ① 有害な作業環境(第1章)(第576条～第592条) 粉じん、騒音、(振動、腰痛、上肢障害、熱中症等)、いわゆる作業関連疾患への対応について
- ② 廃棄物の焼却施設に係る作業(第1章の2)(第592条の2～第592条の7)
- ③ 第2章から第9章(第593条～第634条) 各規定の位置づけ

この部分は、安全、衛生ともに共通して整理できる部分かと思っておりますので、浅田先生にもご参照いただければと思いました。特別規則の整理をしていただくうえで、注視していただきたいと思ったのが、受け止め側の目線です。先ほど北岡さんが安衛法等のエンフォースメントに関心をお持ちゆえに指摘されたことと関連すると思われるのですが、規制が発展していくこと自体は喜ばしいことなのですが、焦点がぼけてしまうという弊害もあります。受け止め側、つまりルールを遵守する側からすると、構造も複雑で何をやればいいのか分かりにくくなるという問題が出てくるわけです。安衛法も工場法時代であれば、極論すれば原理原則だけが書かれていたゆえに、自分たちが労災を防ぐために尽力しなければならないという受け止め方になるでしょう。しかし令和の時代では、規則や通達が膨大化・複雑化して、どこをどう読めば自身の事業でコンプライアンスが果たせるのか、理解することさえ難しくなっています。その上各ルール間の関係性なども今一つ分からないという事態になりかねません。そうすると、現在法律本法においては、よく読めば工場法時代から定められているような原理原則は書かれています。監督行政についても、条文でハッキリ規制はしていないものの、労災リスクがあるような局面では監督指導ができるように、根拠条文が設けられています。しかし、そういう条文はあるにせよ、実際は規制が発達しているがために、規則に書かれていないことはやらなくてもいいという受け止め方をされる。そういう問題が出てくるから、たとえばこの部分（※藤森資料1頁「(1) 労働安全衛生法との関係」、「第4章「労働者の危険又は健康障害を防止するための措置」・「第7章「健康の保持増進のための措置」」は原理原則を定めていますが、規則が細かいことを書いているがゆえに、逆に規則に書かれていないことはやらなくていいという誤解を生まないような施策とはどうあるべきか。これらの関係性はどう理解すればいいのか。以前の厚労科研のプロジェクトにおいて、私なりの提言を書きました。要は、規則に書かれている内容に縛られない解釈の仕方が必要ではないか、そのことを立法によって明記すべきではないか、といった内容を書きましたが、この点先生方のお考えを示していただければと思います。

他にご意見・ご質問はありますか。

畠中 一点よろしいでしょうか。藤森資料に「対象とする労働衛生関係規則」として11の規則が挙げられていますが、事務所衛生基準規則は特定の有害物を対象とした規則ではなく、事務所という就労場所についての衛生基準規則です。そして安衛則第3編に定められた衛生基準は適用されない旨規定されています。いずれにせよ、11の規則の中でも事務所衛生基準規則は特殊なものなので、おそらく扱いにお困りではないかという気がします。事務所衛生基準規則も有害要因を対象とした他の規則とまとめて検討するかどうか、その辺りはハッキリさせたほうがよろしいかと思えます。

藤森 ありがとうございます。有害性が高いという観点では、畠中先生のご指摘通りです。藤森資料1頁に挙げたように、①～⑧のいずれの規則も昭和47年に労働省令36号から43号まで連続して制定され、そういう意味では相関関係がみられます。そういう観点でリストアップしてしまっていて、有害物質規制という観点では、確かに畠中先生ご指摘のような問題はあると思えます。

三柴 他にはいかがでしょうか。

唐沢 藤森資料で報告されたのは、労働衛生関係の有害物関連の特別規則の統合という、非常に大きな

テーマだと思います。欧米の安衛法の規則体系に興味関心を持っている者の一人として参考のため申しますと、アメリカでは化学物質ごとの原則として基準（スタンダード）を作っていく仕組みになっていますので、有害物質規制の統合・統一という観点はそもそもありません。イギリスの場合は、有名なところでは有害物管理規則です。イギリスでは鉛関係の規則が先行して整備され、その後有害物管理規則ができていますので、イギリスでは鉛関係の対応は鉛規則でなされ、有害物管理規則は適用されません。ドイツですが、前回の会合の直前にご参考までにとということで、ドイツの有害物規則の英語訳と日本語の仮訳を対訳にしたものを資料としてお送りしました。それをまたご覧いただければと思いますが、ドイツの危険有害物規則は、有害な物質と爆発・火災といった物理化学的危険の両方をカバーしています。ただ、ドイツの場合規制内容はあまりきめ細かくありません。日本の労働衛生関係特別規則の方がはるかにきめ細かい規定になっています。今後、危険有害物関係の統合化を図るか否かという問題をご検討いただく際に参考になると思われまますので、念のために申し上げた次第です。

藤森 ありがとうございます。またご教授いただくこともあると思いますが、よろしく願いいたします。

三柴 ありがとうございます。

唐沢 もう一点よろしいでしょうか。畠中先生の問い（Q）がいくつかありましたが、解答例を作っていますので、後ほど皆さんにお送りします。完璧な答えかどうか分かりませんが、一応ご参照ください。

三柴 ありがとうございます。時間の関係もありまして、先に進ませていただきます。

次は私の報告で、「旧安衛則の性能要件規定」についてお話したいと思います。ここしばらく、旧安衛則の整理をしています。その狙いは、実質的には畠中先生にお話しいただいた内容の確認ないし裏付け、そしてこれをより詳細化するという形になると思います。要するに、今の安衛法ができる直前まで旧安衛則による規制がなされていたので、何がどう変わった結果労災が減少したのかを浮き彫りにしたいということです。作業の内容としては、まずブリーフを作り角田先生のサイトからも図を拝借させていただき、内容理解に努めました。そして旧安衛則の名宛人を整理しました。名宛人を整理していくと実に興味深く、色々なことが分かります。もともと安衛法は、労基法のように基本的に労使のみというものではなく、名宛人が多様であることに特徴があるのですが、旧安衛則の時代からそうでした。整理していくとそのような特徴がよく分かります。そもそも名宛人を明記している規定と、書いていない規定があります。現行の安衛法になってはじめて名宛人が書かれるようになった規定もあるのですが、旧安衛則時代に名宛人が明記されていなかった規定のようなものが、今でもけっこうあります。また、名宛人が一応書かれているのですが、名実ともにその名宛人を対象に規制しているものがあるほか、一応名宛人や主語は書かれているものの、あくまで形式的な主語に過ぎず、実質的に規制対象は別の人であるような規定もあります。たとえば、物を主語にしているながら、実際に規制対象としているのは使用者であるとか、使用者だけでなく国も規制対象に含めていると思われる規定など様々な規定があり、非常に多様な分類となります。旧安衛則の時代からそういう状態であったということが分かります。また、旧安衛則時代から、労使以外の様々な対象者をカバーしているということが見て取れます。特定機械や特定の化学物質

のような物の製造者や譲渡提供者や、資格制度を設けている場合はその資格を取得しようとする人や取得した人を規制対象とする規定もあり、また行政を名宛人として一定の権限を付与するだけでなく、しかるべき措置を義務づける形で規制する条文もかなりあります。

しかし他方で、旧安衛則時代から現行の安衛法時代にかけて大きく変化した点も見受けられます。畠中先生からもご指摘いただいたとおりですが、安衛法の体系が整理されました。整理体系化がしっかりとされた結果、現行の安衛法となったというのが際立った変化です。藤森先生が以前ご説明されたことですが、一番上に安衛法本法があり、施行令が定義説明を行い、規則や通達があるといったように、上から下までの体系化が進んだということです。ただ、整理体系は“一応”なされたというべきかもしれません。というのも、浅田先生がご指摘のように、規則のうち根拠のある、つまり安衛法本法で省令に委任する旨の定めがあって施行されている規則と、“実施省令”と言われるように根拠条文が定かでないまま専ら厚生労働省がつくった規則もあり、整理体系化が完璧になされているとは言い切れない状態です。しかし、旧安衛則時代に比べると、法令の体系として優れたものであることは明らかです。

内容的にも相当に追加されています。特に災害防止に効果的だったのではないかと思えるのは、畠中先生もご指摘されていましたが、安全衛生のための管理体制の整備です。旧安衛則時代は使用者に一定の措置を義務づけた危害防止基準が中心で、再発防止のための分かり易いマニュアルを規則化したようなものでした。技官の方が中心になって作った様子が透けて見えるような、マニュアル規則のような感じでした。これに対して現行の安衛法は、災害防止のためにはどのような管理体制が必要なのかという、一步引いた目線で管理体制の整備を相当に重視しています。その一環として、統括安全衛生責任者やそれをめぐる体制が規定されました。労災を防ぐためには、単に直接使用者に何らかの義務を課すだけでなく、間接的にどう対処すべきかという視点を、現行安衛法が持っているということがよく分かります。

しかし、立法過程における複雑な状況について畠中先生からお話があったところですが、現行の法体系をもって完璧に仕上がったわけではありません。制定当初から急ピッチで作業を進めていたがゆえに欠落してしまった部分もあると思いますし、新たなリスク要因が出現しているため、それに対応しなければならない点もあるでしょう。大ざっぱに言うと、今取り組んでいる作業の中から以上のように感じられるところです。

さて、本題の性能要件に移ります。現在、新たなリスク要因が出現しています。メンタルヘルス関係のものであったり、あるいは癌にかかっても働き続けられるようにといった、どの省庁が所掌すべきか、また厚労省の中でもどこの部局が所掌すべきか微妙な点を含む課題に至るまで、安衛法が扱うようになっています。確かに安衛法第1条や第3条をみれば、当然安衛法が扱うべき問題だということは明らかなのですが、時代を経た今だからこそクローズアップされてきた問題であるといえます。そういう問題に対峙するためには、結果を担保することが肝要でそこに至るまでのやり方は事業者に分権化して自由裁量に委ねるという方法も重要であろうということで、性能要件規定というテーマに着目したというわけです。（※以下「旧安衛則の性能要件規定」（以下「三柴資料」とする）に基づいた報告）旧安衛則時代はどうなっていたかを整理してみると、相応の数の規定がありました。たとえば、「但書を設けている例」です。原則を定めつつ、但書きで逃げ場を残すやり方です。また、単にただし書きを設けているだけではなく、「但書を設けている場合で、なおかつ、達すべき性能を明記している例」もあります。一例を挙げると汽罐室、今でいうボイラー室には「2以上の出入口を設けるべきこと、但し、避難に支障がない場合はこの限りでない」（第300条）と書かれています。要するに避難ができればいいという趣旨を明確



にして、それさえできるのであれば本文に規定した以外の方法をとってもいいということです。何ができればいいかを明示した上で逃げ場を作っているということです。それと、「適用除外規定の例」もあります。当時の方がドラスティックに認めていたと感じさせるのが、「第2編」や「第4編」のような大きな規定群を包括して、「作業の性質その他やむを得ない」場合には、所轄の労基署長に適用除外の申請をして認められれば規制を遵守しなくてもよいということになっていました。このように、安全基準や衛生基準の大部分を一まとめにして、行政の許可を条件に例外を認めているわけです。このような規定が旧安衛則時代には存在したのです。例外を認める要件も、「作業の性質その他やむを得ない事由」といったアバウトな書き方でした。法制史の研究対象として大変興味深いところです。また、「複雑で危険性の高い機械について、一定の性能を充たす場合に、一定の基準の逸脱を認めた例」です。特に今でいう蒸気ボイラーに関して認める例がありました。「複雑で危険性の高い機械の性能について、行政がまさに性能検査を行い、それに合格したものに取扱いを許可することを定めた例」、行政の人間の目線で大丈夫だと認められれば規制を外すということです。行政ではありませんが、「複雑で危険性の高い機械をもたらし危険につき、主任者による人的管理を義務づけた例」もありました。これは、解釈の仕方によると思うのですが、職場で事業者が選任した専門家にその取扱い方法の詳細を委ねるという趣旨でもあります。主任者を配置して危険な機械を取り扱わせるというのがどういうことかということ、法令で取扱いの基本は定めるものの、詳細部分についてはその人の指示に従いなさいということです。ですから、広い意味では性能要件的な規定という性質をもっていると理解できるわけです。次に、「危険性の高い機械のもたらし危険につき、その機械には該当するが、一部の危険性の低い機械につき、要件を緩和した例」もありました。

また健康関係では、今でも特別規則の中に似たような規定が多々ありますが、「健診につき、医師が認めた場合か、実施困難な場合に一部の健診項目を省略できることとし、なおかつ労基署長への届出を課した例」が当時からありました。ただし、たいいていの場合労基署長への届出が必要となります。興味深いものとしては、クレーン、デリック、エレベーターのような複雑かつ危険なものに関して、「複雑で多様な規制対象につき、対照的な代表例を選択して規制し、その他の例が参考にするよう誘った例」・・・実際のルールでは規制対象のうち一部だけしか明記されていない、しかしそれは例示列挙のようなもので、代表的なものを書いてあるので参考にせよという趣旨の規定です。これがなぜ性能要件的な意味を持つかと言えば、“参考にせよ”ということですから、代表的な規制対象について行われている規制をそのまま援用せよというわけではありません。あくまで“参考にして”それぞれの機械について、その危険の度合いに応じてしかるべき対処をしてくれればいいということです。これも一種の性能要件の規定ではないかと思うわけです。

そのほか、「実質的な性能要件規定」と認められるものとして、「一義的に明確な定めを置きつつ、柔軟な解釈運用を認めている例」がありました。たとえば、揚重機は、組立後、制限荷重の20%増しの荷重による試験（荷重試験）を行うべきことを定めた第366条のような規定が当時からあったわけです。これについては、条文の上では何をどうすればいいのか一義的にはっきりと書かれていますが、解説書を読むと、設置場所での組立前、製作所での試験による代替が認められることがあるということです。条文に書かれていることと異なった運用をして差支えないわけで、これも安衛法らしい解釈であると思います。一応、一義的に明確な定めを置いているのですが、解釈運用でそれを曲げてもいい、いわば“解釈改憲”をしてもかまわないという例です。そして、そもそもが「抽象的な定め例」で、いろいろな読み方



ができるので、現場の実情に応じて解釈してくれという規定があります。たとえば、自然発火の危険がある物を積み重ねる場合、危険温度への到達防止措置を講じるべきことを定めた第147条などです。書き方が非常にあいまいで、これをどう読むかは現場に応じて変わるわけです。こういう規定を運用する場合には、なおのこと監督指導する行政官の目利きが求められます。ですから、昔の監督官の方が安全衛生規制に関しては、人材が育ちやすかったかもしれません。それほどルールがある意味アウトで、それをどう活用するかという点では目利きでないと困るのではないかという気がします。現在、安全衛生技術に詳しい行政マンが減っているのも、こういうルールの建てつけが影響しているのかもしれない。

最後ですが、「講じるべき措置を例示列举とした定め」がありました。ガス、蒸気又は粉じんを発散する屋内作業場では、空気中の含有濃度を有害な程度にならないよう、局所排気や機械装置（発散源）の密閉、換気「等」の適当な措置を講じるべきこととした第173条です。具体的な措置を挙げていますが、“等”をつけることによって、他の方法をとれる可能性を示唆しています。これも実質的には性能要件規定と解することができます。

ともあれ、何を目的・目標にするかを明確にした上で法制史を調査すると、色々なことがわかるものです。こういう形で温故をしながら知新をしていければ、相応の成果になるのではないかと思います。

以上、私も未だ調査不足ですが、ご意見・ご質問ございますでしょうか。

浅田 ご教授いただきたいのですが、三柴資料で挙げられた旧安衛則ないし現行安衛則の条文は、いずれも違反に対して刑事罰が科されます。そうすると、構成要件の明確性という大きな要請がかかわってくると思います。あまりに抽象的すぎると、罪刑法定主義という大原則に反するのではないかということです。したがって、刑罰法規とはいいいながら、実際は不可罰規定になるのではないかという懸念があるのですが、その辺りはいかがでしょうか。

三柴 端的にお答えすると、今ご指摘された問題は、安衛法に関しては必ずしもそうではないのではないかと思います。つまり、罪刑法定主義は運用上厳しく求められていなかったといえると思います。うがった見方ですが、安全衛生の規制はもともと構造的に、全てのリスクを明文のルールできれいに定めることは無理だと思われれます。しかし、現場では色々な形で危険が生じます。したがって、危ないと分かっている危害の再発防止策はルールに定めておく一方で、リスク管理を幅広く事業者に委ね、それに加えて川上にいる製造業者のような人たちが動いてくれないと防ぐことはできない災害については、そういう人たちに委ねる。リスクを創出する人たちや影響を与え得る人たちが対策を講じるべきだとする世界です。少なくとも、裁判所は安全衛生のそういう本質を理解していますから、安全衛生法規について柔軟な解釈をとってきました。当事者間のもめ事を上手く収めるための民事事件は言うに及ばず、刑事事件において当時からかなり柔軟な解釈がなされてきたという例があります。下の図のとおり、ある作業者がコンクリートの打設作業を行っていましたが、支保工も杜撰で雨が降っている日に不安定な状態で作業を行っていたものですから、支保工の崩壊により落下し死亡したという事件です。亡くなった作業者は、数次に及ぶ多重下請の会社で働いていたのですが、彼に直接作業指示を行っていたのは元請の作業管理者でした。当時の安衛則は、元請を対象とする規制がありませんでした。少なくとも元請をはっきりと名宛人として、この事件のような状況下でリスク対応を義務づけた規定はこの当時は存在していません。しかし、監督署は元請の作業管理者を逮捕し、刑事処分をしようとしたので、元請側は罪刑法定主義

に反すると主張したわけですから。これに対して裁判所は、労基法第10条にいう「使用者」の概念は、画一的に定めることはできないのであって、例えば、賃金支払い面での使用者と安全衛生面が一致する必要はない、と解しています。施工を担当する下請人に労基法上の安全措置義務を尽くすだけの能力がない以上は、実質的に考えて工事を総括する元請人がこれを負担しなければ極めて不合理不都合な結果を生じる、としています。当時の労基法第10条と第42条にいう「使用者」として、元請の作業管理者がこれに該当すると解釈するのが妥当であるという結論でした。これは民事事件ではありません、刑事罰を科すための刑事事件です。当時から、このような司法判断は存在していました。これをシステム化し分かりやすく見える化したのが現行法であるという理解も可能です。現行法の解釈も、法整備が発達した分だけ法令により準拠した解釈をする傾向にあるのでしょうかけれども、やはり安全衛生規制の本来的な目的を意識した、趣旨に適合した解釈というのは、当時も現在も変わらずなされているのではないかと思います。その点、内閣法制局は“法律頭”ゆえにやいのやいのと言っていますが、実際に裁判ともなればこういう運用が当時も今もなされているのではないかと、沿革を洗っているとなんとなくそのように感じます。

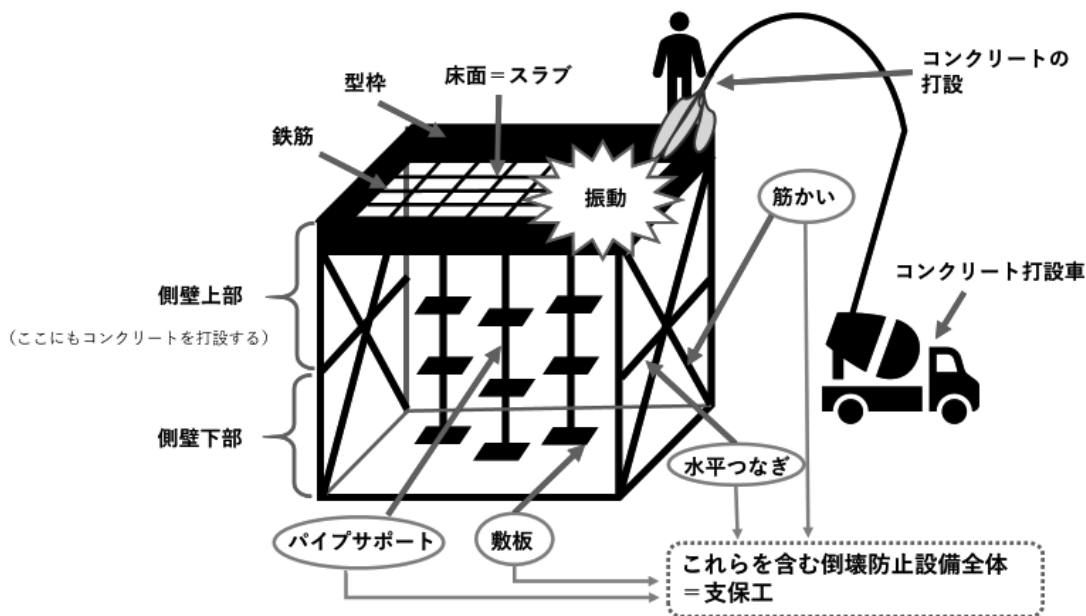

浅田 ありがとうございます。名宛人についてはかなり弾力的な解釈がなされているようですが、措置義務についても、同様な状況をうかがわせるケースはあるのでしょうか。

三柴 措置義務については、民事事件においては明文規定がなかったとしても使用者の安配義務などの内容として認められることがしばしばです。刑事事件においては、もう少し調査してみますが、措置義務については割と法令の内容に即した判断をしているようです。ただ、抽象的な内容の規定も用いてきたように思います。上記の事件も措置義務については割と曖昧な定め方をしていまして、使用者は・・・必要な措置を講じなければならない、といったような規定だったと思います。なので、措置義務も曖昧な内容の規定を割と上手い具合に使ってきたという面もあるかもしれません。もう少し調査してみるつもりですが、この一例をとってもそういうことがいえるのではないかと思います。

浅田 ありがとうございます。

北岡 ただ今のお話ですが、刑事事件については、実際に起訴するかどうかについて労基署に決定権限はなく、送検した上で検察官が判断します。一般的に安衛法違反の事案について、送致処分をするかどうかという段階で、検察官や監督官の方でかなり綿密に調整をしています。そこで一般的には、法律や施行規則の文言に照らして構成要件を充たしている事案を送致するのが基本かと思います。悩ましいのは、施行規則の文言で「必要な措置を講じる」などといったあいまいな内容の条文になっていて、それについて細則で行政通達が示されている場合です。そういう場合、行政通達に書いてあるから処罰できるかという、私の経験からすると検察官はそういう場合相手にしてくれません。検事に言わせると、行政通達ではダメだ、せめて施行規則に書いていないとダメだ、そもそも法律に書いていないじゃないか、ということになるわけです。私も検察官から何回かそういうお叱りを受けたことがありました。施行規則に文言があるものについてのみ刑事事件になっているのかと思います。ですから、構成要件で若干微妙な点や法文上ハッキリしないものについて、実際に送検・起訴されたケース自体あまりないのではないかと思います。しかも、略式起訴のケースがほとんどなので、基本的には公判は開かれず、判決の記録も残りません。そういう実態が安衛法違反事件には多いのかもしれない。

三柴 今ご指摘いただいた検察との現場でのやり取りについては、私も多々耳にしてきました。まさに今仰ったとおりだと思います。先ほども申しましたように、規制の発達のおかげもあって、措置義務については法文上書かれていないことまで読み込むことは多くはないと思います。ただ、検察からみて、ルールの欠缺があるけれども、処罰しておかないと秩序論としてまずいのではないかという価値判断が働くようなケースがあるはずです。そこは、柔軟な法解釈で運用する場合があるのではないかと思います。たとえば、化学物質を原因とする胆管癌の問題が印刷工場で発生しましたが、あの問題については、発がん性の分類の問題から当時は措置義務的に処罰はできませんでした。それで結局、産業医の選任義務違反や衛生委員会の設置義務違反を問責したわけです。やるべきことをやっていなかったという価値判断との調整なのではないでしょうか。もちろん、一般的なケースでは明確な危害防止基準に反しているかどうかハッキリしていないと、立件する側は起訴しても公判を維持できず、有罪率も低下します。しかし、ルールは欠けているけれども、どうしても処罰しておかないとマズいケースについては、安衛法の場合は柔軟な解釈をとる傾向があるのではないかと理解しています。

北岡 なるほど、ありがとうございます。

三柴 だいたい時間なんですけど、よろしいでしょうか。予定していた内容は概ね以上です。もう一点、機械の本質的安全化についてご執筆いただける方がいらしたら、ご紹介をしていただきたいと思います。あらためてお願いいたします。また、先ほど申し上げた建設安全等の発注者の責任について書いていただける方がいれば、ぜひご紹介をお願いいたします。

ということで、本日のメニューは以上です。長時間にわたりありがとうございます。本日ご報告いただきました畠中先生、浅田先生、藤森先生、またすでにご退出されましたが森先生に、あらためて御礼を

申し上げます。

三柴 本日もお忙しい中ご参集いただきありがとうございます。本日も先にMLでお知らせした議事要領にしたがって進めていきたいと思えます。まず研究経過からお伝えします。私の方で統括的に進めている調査研究がありまして、以前もお伝えしたかと思えますが、一つは初年度に実施した日本における企業の安全衛生関係者向けの調査内容です。たとえば、経営者が安全衛生を重視しているというのであればそれはなぜか、重視している証としてどのようなことをしているか、逆に軽視しているのであればそれはなぜか、などといった質問に回答してもらう形で調査をしました。これと同様の調査をイギリスで実施しています。イギリスにも社会調査を代行する業者があり、中でもY o u G o vという会社が比較的安価で引き受けてくれるということで、概ね100万円弱程度の料金で1000サンプルほどの結果を採ってくれるそうなので、すでに発注して担当者との間で質問内容等の微調整を行っているところです。もうすでに調査を実施しているか、あるいは少なくとも準備の最終段階に入っていると思えます。日本で実施したものとはほぼ同じ内容の調査になりますが、やはり国ごとの違いがあるので、同じ質問項目を立てたとしても、“この質問の仕方では上手く伝わらない”などといった問題もあり、質問項目を作る段階から文化の違いを感じさせられます。興味深かったのは、日本で高齢者の安全衛生が重要な課題になりますが、イギリスの場合基本的には60歳以降になると働かないので、高齢者の安全衛生に関連する質問は意味をなさないということです。

もう一つは、国内向けの調査を進めています。このプロジェクトでは安衛法の本格的な体系書をつくろうと試みているのですが、特徴の一つとして、今までの解説書にはなかったような具体的なイメージを伝えられる本にしたいと思っています。ですから、写真や絵図を多用するのもその一環なのですが、それとあわせて行政官の方に条文の使われ方について尋ね、それを多く載せていこうということです。つまり「適用の実際」です。現場での適用例を調査して掲載していこうと考えているところですが、そのために今年度は、行政官向けに法令の条文がどのように使われているか具体例を挙げてくれるよう調査をかけています。幸い本省の方から各都道府県労働局と労基署に通達してくれたおかげで、現在時折質問の趣旨について問い合わせを受けているという状況です。けっこう関心を持って真剣に回答してくれるところが出てきそうな塩梅です。全国に400カ所余り、紙ベースで調査依頼をかけております。仮に回答数としてはさほど集まらなかったとしても、内容的にそれなりに充実した回答が得られるのではないかと期待しています。この調査を実施するに当たっては、藤森先生にご協力いただいています。また、量的な調査とは別に、あらためて質的な調査についても藤森先生にお願いをして、何名かに直接インタビューすることも考えています。こうした作業を通じて、どの条文がどのように使われているかという情報が入手できたら、メンバーの先生方に拡散しますので、分担報告書の中の「適用の実際」に記載していただければ、各先生方にとっても各条規のイメージが把握しやすくなり、読み手にも伝わると思えます。こうした取り組みは従来の解説書の中ではなかなかなされていなかったと思うので、有意義な作業であると考えているところです。

次に、本日のメインイベントである唐沢先生のご講話をお願いしたいと思います。論題は、海外の安全衛生法制度から日本が学ぶべきことです。安衛法の基本的なシステムと、特に化学物質対策に注目したお話しをいただきたいと思えます。

唐沢 事前に皆さまに資料をお送りしたと思えますが、まず私の資料（※「海外の安全衛生法制度から日本が学ぶべきこと～安衛法の基本的なシステムと化学物質対策について～」）、以下目次部分を「唐沢資料



目次」ないし「目次」、本文を「唐沢資料本文」ないし「本文」とする。)の目次をご紹介します。本日の持ち時間は25分ということなので、若干駆け足で説明させていただきますが、目次をご覧いただくと私に与えられたテーマが海外の安全衛生法制度から日本が学ぶべきことということでしたので、まず海外の制度がどうなっているかをご紹介します必要があります。そこで、アメリカ、イギリス、EUそしてドイツの制度を紹介しました。アメリカでは1970年に、当時としては総合的な労働安全衛生立法を初めて成し遂げました（I-1）。イギリスの場合は1972年にローベンス報告が出され、その結果1974年に現在のイギリスにおける安衛法に相当する法律ができています（I-2）。それに影響を受けた形でEUが労働安全衛生枠組み指令（Directive 89/391 EEC）を出しています（I-3）。さらにそれを受けて、ドイツでは労働社会問題省が目次I-4で紹介しているように、EU指令をドイツ国内に施行する法律を採択・施行しています。他にも中国など様々な国を調査していますが、日本にとって参考になるのはおそらくアメリカ、イギリス、EU、ドイツであろうということで、今回はこれらの国々に絞ってお話をさせていただきます。そして、目次「II 上記Iに概説した、「アメリカ合衆国、英国、EU及びドイツにおける労働安全衛生法の展開」が日本の労働安全衛生法制に与えている示唆について」ということで、4項目ほどの提案ないし私見を示しています。目次III以降では化学物質対策ということで、アメリカ、イギリス、EU、ドイツにおける化学物質対策を紹介しています。そして最後のIVにおいて、「IV アメリカ合衆国、英国、ドイツ、EU等における化学物質対策が日本の化学物質対策に与える示唆」ということで、5項目にわたって私の提案を示しています。

それでは本文に移ります。おそらく各国の法制度についてお詳しい方ばかりかと思われまので、ざっとご紹介をさせていただくという形にします。本文においては、左側に英語の原文、右側に日本語訳を記載しています。まずアメリカについてですが（本文1頁～）、先ほども申しましたとおり、1970年に当時としては世界初の総合的な労働安全衛生法を制定しました。当時の大統領であったニクソン大統領によって署名がなされています。アメリカ合衆国の安全衛生法の概要は本文2頁のとおりですが、私の理解では本文3頁「3 アメリカ合衆国労働安全衛生法の基本的な仕組み」に記載したとおり、「労働安全衛生法は、基本的には、アメリカ合衆国全体に及ぶ安全衛生基準を作り、それに違反している使用者（the employer）を罰則で取り締まるといったものである」というのがその性格です。

次に「I-2 英国の状況」（本文3頁）ですが、歴史的背景としてはイギリスは工場法等により早くから労働安全対策を手がけてきましたが、変革の契機になったのは、1972年に公表されたローベンス報告で、この報告に基づいて1974年に制定・施行されたのが「職場における保健安全等に関する法律」（略称：HSWA）です。そして、本文4頁に赤字で表記した「2 HSWAの主要な条項」のうち、もっと重要なものは「2 使用者の被雇用者に対する一般的な義務」の条項です。それと「3 被雇用者以外の者に対する使用者及び自営業者の一般的な義務」であり、使用者だけでなく自営業者を対象として一般的な義務を課しているのがイギリス法の特徴です。その詳細な内容として、「自営業者に対する2015年の英国HSWAの一定の規制緩和の改正の内容について」（本文6頁）に記載しましたが、ディテールの内容であるため後回しにします。イギリスのこのような考え方は、その後のILOやEUを中心とするヨーロッパ各国での安全衛生対策にも大きな影響を与えたと考えられています（本文12頁）。

イギリスが与えた影響の一つが「I-3 EU（欧州連合）の労働安全衛生枠組み指令（Directive 89/391 EEC）の概要」（本文13頁）ということですが、これは1989年に公にされた指令です。この枠組み指令には前文があるのですが、ここでは当時のEU・EECの労働安全衛生の状況を俯瞰的に眺

めていて、現在もなお色褪せない格調の高いものになっていると思います。そして第2パラグラフにあるように、「多くの場合、技術的水準及び自主的規制基準を定めている各国の規則は、安全衛生保護水準の点で差異が大きく、安全衛生を犠牲にして競争に走りかねない余地を残していることに鑑みこの枠組み指令を制定したとされています。以下枠組み指令の具体的内容を記載しましたが、詳細は割愛させていただきます。

「I-4 ドイツ連邦共和国における状況」（本文18頁）ですが、ドイツは労働安全衛生枠組み指令（Directive 89/391 EEC）を国内法に導入するために法律をつくりました。名称を「労働時の就業者の安全及び保健を改善するための労働保護措置の実施に関する法律」、略して「労働保護法」といいます。そのような法律を制定・施行してEU指令を国内法に取り込んだわけです。

今回の報告で私が言いたいのは、本文24頁のIIにあるように、上記Iで概説したアメリカ合衆国等の労働安全衛生法制が日本に与える示唆がどのようなものかということです。まず一番目が、使用者及びその被雇用者（労働者）の関係のみならず、次の者に対する義務もさらに充実する方向を検討する必要があるのではないかとということです。日本の労働安全衛生法第3条と第34条には本文24ページ掲載のような包括的な義務が規定されていて、これらの規定そのものは現在でもなお重要な規定であると思いますが、これに加えイギリスのように（本文6～11頁）「労働に用いられる物品若しくは物質又は機械器具に関わる製造者及び輸入者の一般的な義務」を加えてはどうかということです。また、「被雇用者以外の者（地域住民、訪問者等）に対する使用者及び自営業者（いわゆるフリーランサーのような者を含む）の一般的な義務」を課し、さらに「自営業者に対しても、自らの労働安全衛生の確保を図らせるため、労働安全衛生法上の安全衛生基準の遵守を義務付ける」ことにしてはどうか、などといった私見を提示しています。なぜそのような意見かと言えば、25頁にありますように、「グレートブリテン及びアメリカ合衆国が公式に公表した自営業者の死亡労働災害統計資料」です。グレートブリテンでは、自営業者の死亡災害は全死亡災害の30%に達しています。アメリカの場合でも、自営業者の死亡災害は全体の20.9%に達しているという状況です。ドイツやフランスでは、自営業者の死亡災害統計はとっていないようで、探してみましたが見つかりませんでした。日本においては自営業者を対象とした労働災害統計については、厚労省も実施していないのでデータがありません。しかし、日本でも自営業者の労働災害は死亡災害も含め、かなりのウェイトを占めているのではないかと思います。そこで、先ほども述べた通り、自営業者にも労働安全衛生基準の遵守義務を課してはどうかという提案をしています。

次に本文26頁の3ですが、「使用者による労働者の安全及び健康に対するリスクの評価（リスクアセスメント）を実施する者は必要な専門的知識及び技術を有しなければならないものとする」と。そして4番目に、「EUの労働安全衛生枠組み指令第6条第2項の次のような規定を、英国やドイツが対応しているように、日本の労働安全衛生法に盛り込むこと。そうすることによって労働安全衛生対策の優先順位をより明確にすることができるであろうこと」です。すなわち、同条同項には「(a) リスクを回避すること、(b) 回避できない危険を評価すること、(c) 発生源でリスクに対処すること（以下略、詳細は本文26頁参照）」などといった定めがあり、イギリスやドイツではこのような内容を法令の中に取り入れています。わが国でもこうした試みを実施してはいかがかということです。

以上が前半のお話です。次は、「III アメリカ合衆国、英国、ドイツ、EU等における化学物質対策について」（本文27頁）です。各国において化学物質対策がどのように行われているのかにつき、一応網羅的に調べてみましたが、今回はあまり時間もありませんので詳細は省きますが、本文記載の通りになっ

ています。アメリカの化学物質の規制は、本文27頁記載の状況になっています。各項目のアクティブリンクをクリックしていただければ、網羅的に並べた安全衛生基準や規制内容が分かるようになっています。「Ⅲ-2 英国における状況」ですが、現行の「健康に有害な物質管理規則」というものがあり、これによって規制がなされています。イギリスにおいてもう一つ重要な規則は、「職場での健康安全管理規則」です。関心のある方は後ほどご覧いただければと思いますが、これらの規則の要点を紹介しています。イギリスに次いでドイツですが、ドイツの危険有害物管理規則を全文紹介していますので、索引的にご覧ください。

以上のような前提に照らして、「Ⅲ-3 EUにおける状況」（本文79頁）ですが、EUは「職場で化学物質にさらされるリスクからの労働者の保護に関する指令（98/24/EEC）」を出していき、それが化学物質対策の規則になっています。もう一つはがん原性物質対策がなされており、原文81頁にありますように、「職場でがん原性物質又は変異原性物質にさらされるリスクからの労働者の保護に関する欧州議会及び欧州理事会指令（2004/37/EC）」が2004年に出され、最終改正が2014年の2月になされています。その後改正されていません。内容の詳細は時間の都合上割愛させていただきます。原文88頁にあるとおり、「物質及び混合物の分類、表示、梱包に関する指令」というものがEUの規則として出されていますが、これも化学物質規制の一部であるといえます。最後に少々触れておきたいのは、「EU委員会による化学品に対する新たな総合的な規制（REACH）」（原文91頁）で、これは化学物質ではなく「化学品」に対する規制で、化学品の登録評価に加え、制限に関する規則があります。

以上がアメリカ、イギリス、ドイツ、EUが化学物質について課している規制の概要になりますが、本文97頁のIVにて、これらの国の化学物質対策が日本の化学物質対策にどのような示唆を与えるかということを示しています。一つは「1 化学物質が労働者の健康に与える影響を監視する枠組みの一層の充実」を図ってはどうかということです。現在厚生労働省は、労働安全衛生規則第95条の6の「有害物ばく露作業報告」という制度を数年前から運用していき、私もその関係委員会の委員の一人として参画しております。日本が現在運用しているこのような有害物ばく露作業報告制度は、アメリカ、イギリス、EU、ドイツを調査した限りでは見当たりませんが、大変優れた制度であると考えられますので、これをさらに的確に運用してゆくことが重要ではないかと思います。また、イギリスでは職業病が疑われる場合の内科開業医からの通報制度、ドイツでは社会法典第7編に盛り込まれている同業者労災保険組合における医師によるデータの収集・データ処理、職業病の場合における医師の届出義務等が規定されています。このような規定を今になってわが国で具体化するのなかなか大変だと思いますが、このような制度をわが国で樹立することを検討する必要があるのではないかと思います。二番目に「2 有害な化学物質について、労働者の職業上のばく露限界を、アメリカ合衆国、英国、ドイツ、EU等が行っているように、日本の労働安全衛生法令の中に規定して、その限度以上にこれらの物質に労働者をばく露させないことを義務付ける」。これは現在、わが国は作業環境評価基準の中で管理濃度として規定しているが、その限度以上にこれらの物質に労働者をばく露させないことを事業者に直接義務づけているわけではありません。それから三番目に「3 欧州化学品庁が組織しているリスクアセスメント委員会のような常設の委員会のような常設の専門家会議の設置及び運用」です。このリスクアセスメント委員会は非常に活発に活動している組織で、EU加盟27か国では16世紀くらいから大学の医学部や公衆衛生部門が化学物質の健康被害を研究してきたという大変な蓄積がヨーロッパにはあるようです。そうしたヨーロッパの底力がリスクアセスメント委員会にあらわれているのではないかと受け止めています。

わが国でもこのような、専門家による検討会を法令により強力に推進する必要があるのではないかと考えています。四番目ですが、「4 化学物質に関するリスクアセスメントを担う者について、専門的な知識のある者であることの義務付け」を行ってはどうかということです。関連規定としては、イギリスの有害物管理規則7-(1)に同じような規定があり、「すべての使用者は・・・関連する法的規定・・・によって・・・課される要件及び禁止事項を遵守するために必要な措置を実施するために、その使用者を支援するために、1人以上の能力のある者を任命しなければならない」と定められています。「健康に有害な物質管理規則」の12にも、本文98頁記載のような関連規定が置かれています。また、「承認実施準則及びガイダンス」は、法的拘束力のある規定であり、本文99頁記載の通りになっています。ドイツでは、危険有害物規則第6条の中で、「リスクアセスメントは、専門的な知識を有する者のみが行うものとする。」と規定されています。五番目ですが、アメリカ、イギリス、ドイツ、EUにおいて「法令で規定されている、又は専門的な団体によって公表されている職業上のばく露限界値がある化学物質についてのがわが国でのばく露状況モニタリングの実行」してはどうかということです。アメリカから始まってイギリス、ドイツ、EUそれぞれの、職業上のばく露限界値規定の一覧を原文100頁以降に記載し、法的拘束力のあるものについてはカッコ書きで明記しました。ACGIHなどは法的拘束力はないものの、かなり有力な技術的資料として公表されています。

私からの報告は以上のとおりです。ご質問等がございましたら、その中で必要な捕捉をさせていただきます。

三柴 ありがとうございます。タイトな時間の中で、エッセンスをつめていただきました。先生方の方からご質問などございましたらお願いいたします。

藤森 一点よろしいでしょうか。ご報告で触れられた各国の制度においては、化学物質ごとに基準を作っているようで、全般的に統一的な規制をするという観点はあまりないということでしょうか。

唐沢 私が調べた限りでは、イギリスでは二つの規則、つまり有害物管理規則と鉛規則によって化学物質をカバーしています。ドイツでは危険有害物管理規則があり、これは爆発・火災をはじめ有害な化学物質の中毒を防止し、石綿対策までを一つの規則で対応しています。アメリカの場合は、物質ごとに規制がなされています。

藤森 またご教授いただくこともあると思いますが、ありがとうございます。

森 ひとつご教授いただきたいのですが、ご報告の最後の方の人材に関する箇所、リスクアセスメントに関する専門的な知識を有する者のお話がありました。これは、規制対象が化学物質であるがゆえに「専門的な知識を有する者」が求められるのか、それとも一般的なリスクアセスメントについても同様に相応の能力のある人が実施しなければならないのか、その辺りはどのような関係になっているのでしょうか。

唐沢 私の意見としては、双方のリスクアセスメントについてそのような人材が実施すべき旨を提案し



ています。

森 ありがとうございます。

三柴 森先生はご存知かと思いますが、アメリカもイギリスも民間が安全衛生関係の資格を発行していて、かなり強気なコンテンツを用意しています。カリキュラムも百数十時間OFF-JTで受講しなければなりません。そしてOJTについてはほぼ360度の評価を受け、それでようやくサーティフィケーション（認定）を受けられる仕組みになっています。上級資格と一般資格があり、何を持って上級になるかといえば、安全衛生の管理・マネジメントや化学物質のうち比較的複雑なものの管理などを取り扱うがゆえです。したがって、ケミカルサブスタンスについては、取扱いの対象としては高度なものと考えられているようですが、民間資格も活用しながらコンペtentパーソンをリスク管理にあてることは、少なくともイギリスでは原則になっています。したがって、化学物質管理に関してのみ専門的人材を求めているわけではなく、条文上はリスクアセスメント全体において求めているものと解されます。

森 日本では、リスクアセスメントにおいては現場の人間の関与が強調される傾向がありますが、リスクアセスメントが有効に機能するには本当に解っている人が実施しなければなりません。アジアに調査に行ったときに、アジアの現場の労働者に参加させようと思ってもレベルの問題で上手くいかないということもありました。日本では現場の人たちが“それなりに”読み書きができるがゆえに、中途半端な状態になっている点で、かえって複雑化している感があります。これは、化学物質だけではなく、それ以外のリスクアセスメントについても同様かもしれないと考え、確認させていただいた次第です。

三柴 私自身、森先生と同じ問題意識を持っています。以前社会調査で、日本にリスクアセスメントがなじむかという質問を設けてみました。要するに、伝統的なゼロ災運動のような全員参加の対応のほうに日本に相応しいのではないかと思う一方で、現場で扱う危険有害物質も多様化し、それに素人が対応できるかという問題もあるので、一体どちらがいいのだろうかと調査してみたのですが、森先生と認識は全く同じで、結果はゼロ災運動がいいという人もそれなりの数いました。「リスクアセスメント」という言葉がまだ日本になじんでいないという感もあり、非常に中途半端な状況にあるように思いました。

森 仮に企業が相応の意識を持って専門的知識を持った人を雇い入れたとしても、人材養成ができるかどうかという問題があります。結局現場ではゼネラリストとそう変わらない教育を実施してしまって、専門家として要請しなければならないという認識がないまま、総務部の職員と同じ扱いになってしまうというケースが最近見受けられます。そういう意味で、法令によって専門的知識を持った人材の定義などをしてくれると、企業の意識も変わるのかと思いました。

三柴 その点もまったく同じで、現在厚労省で化学物質管理の検討会を開いていますが、私の主張としては、まずリスクアセスメントはヨーロッパ並みに幅広く法令で義務づけるべきである、その上で事業者が各々の現場で適切な手法で実施でき、必ずしも国が指定するやり方を採らなくてもいいのであれば、専門家のお墨付きを得たうえで免責を図るということです。これまでとは逆転の発想です。特定の基準



で実施すべき義務の内容は最低限にしておいて、その基準を上回る措置を講じるために専門家を活用するというのが従来の考え方でしたが、私の意見は逆に、法令で相応に厳しい基準を設けたうえで、その免除を求めるのであれば専門家を活用せよ、というやり方をすれば、おそらく専門家へのニーズが出てくると思います。これは言わば法制度を用いた“おどし”のようなやり方なので、なじむかどうか定かではないのですが、中小企業で化学物質管理をきちんと実施させようと思うのであれば、これくらいのやり方をしないとダメなのではないかと思えます。ただそうすると、リスクアセスメントの構成要件が曖昧なゆえに、内閣法制局に言わせると罪刑法定主義に反する可能性が生じます。要するに、どのような行為に対して処罰がなされるのかという方程式がハッキリしないと、刑事責任を問うことはできないという問題に抵触します。こういう点では海外とかなり事情が違います。唐沢先生にお尋ねしたいのですが、イギリスにおいてもドイツにおいても、リスクアセスメントは“義務”であり、曖昧な規定のし方で刑罰の適用が可能になっていますか。

唐沢 罰則の適用までであったと思います。

三柴 立法作業に関与された唐沢先生と畠中先生にお尋ねしたいのですが、なぜ日本は安全衛生のような事項についてまで罪刑法定主義を求めるのでしょうか。なぜイギリスやドイツのようにいかないのでしょうか。

畠中 やはり罪刑法定主義は、日本においては崩せない原則ではないかと思えます。前回は申しましたように、たとえば安衛法第29条の元方事業者の指導指示義務ですが、これに罰則がついているとすれば、それこそ請負関係の安全衛生の状態は相当に変わってくるのだらうと思えます。やはり直罰は罪刑法定主義という点からみると、曖昧な構成要件規定を許しません。命令前置主義を採ればまた別でしょうが、やはり罪刑法定主義は厳格さを要求します。

三柴 ご指摘のように、命令前置主義をもう少し活用できないかと私も思うのですが、結局のところ現場の行政官に対する信頼が今一ということなんでしょうか。

畠中 それはないと思えます。

三柴 実際、判例の中には・・・北岡先生、ご意見おありでしょうか。

北岡 失礼いたします。今のお話との関係で、唐沢先生にお伺いしたいのですが、平成28年の報告書を一通り拝読しまして、イギリスの安全衛生法ではリスクマネジメントにおいて罰則規定があることなど勉強させていただきました。この中に、どうしてもリスクマネジメント規制についても、事故が起きてから遡って罰則を科すことをせざるを得ない、つまり事前予防的な罰則規定の適用があまりないという言及があったと思えます。この点について、なぜそうなのか・・・というのも、私自身のイメージでいうとリスクマネジメントというのは手続規制であり、まずしかるべき有資格者に対してリスクを調査させて、これを踏まえて事業者がどのような対策を講じたのかという、手続き上のルールが規定されているわけ

です。イギリスにおいて、リスクマネジメントに罰則規定があるとすれば、事前予防的には機能していないのかという印象を抱いたのですが、この点ご教授いただければと思います。

唐沢 イギリスが具体的にどのように運用しているのか、なかなか調べようがないのですが、ご指摘のような問題はあるかと思えます。イギリスがグレートブリテンの労働災害のサマリーレポートを公表したので、対訳を皆さんにお送りしましたが、グレートブリテンとスコットランドで実際に司法事件となった事案はさほど多くありません。7、800件程度でしょうか。おそらくいずれも災害が起きてから送検された事例かと思えます。実際の運用として、HSEや地方自治体がリスクアセスメントを実施していない使用者に対してどのような対応をしているか、現地調査をしてみないと分からないので、これ以上のことは私も把握していません。

三柴 私の方からコメントさせていただきますと、平成28年度に最終報告書を出した調査の中でHSEにインタビューしまして、なぜ事後送検（災害発生後に法違反を問う）になってしまうのかというところ、法違反を問責できる基準、つまりその災害を防止するために何をどうすべきであったかの特定が事後にならないとハッキリしない、と回答者は指摘していました。ただ、突っ込んでいけば、予防段階でハッキリしないというよりも、事後的に説明する方が説得力を持つだけのことじゃないかと思えます。私はそのように解釈しました。結局、災害が発生してしまった後に、後付け的に“こうすべきだった”とすれば、誰も反論はできません。インタビュー先が答えたのは、簡潔に言うともそういう理屈ではないかと思えます。また、イギリスのリスクアセスメントの規定違反については、HSEのWebサイトで情報が公開されています。確かに件数はさほど多くありませんが、処罰は行われています。これが事業者への行動に働きかけ、予防効果をもたらすことはあるでしょう。なので、規定があるのとないのとでは、やはり違いは出ると思えます。

北岡 ありがとうございます。

三柴 では、唐沢先生のご報告はここまでとさせていただきます。大量の内容を短時間でご報告いただき恐縮です。有益なご提言含めお話いただきありがとうございました。

それでは次に、浅田先生と藤森先生から安全関係の特別規則と衛生関係の特別規則のそれぞれについて、趣旨と概要を解説していただくことになっています。まずは浅田先生からお願いいたします。

浅田 私に与えられた課題は資料のタイトルにあるように、「安全関係の特別規則の趣旨と概要、統合の可能性」（以下「浅田資料」とする）ということになります。まず、「1 対象とする安全関係の特別規則」は、浅田資料1頁1・(1)～(3)に挙げているように、ボイラー及び圧力容器安全規則、クレーン等安全規則、ゴンドラ安全規則の3本です。これらはいずれも、製造から使用に至るまで最も厳格な規制が課された特定機械を含む規制対象に関する規則です。次に「2 主な論点 上記の3本の安全関係の特別規則ごとに、それぞれ次の主要論点について考察する。」として、「(1) 各規則制定の背景・経緯及びその後の主な改正点」としましたが、これを調べるのに最も時間がかかりまして、戦前のものも含めて過去の古い資料にあたって調査する必要があり、相当に難儀したおぼえがあります。また、現行の安衛法と

安衛則との関係がどうなっているのか等、順に説明していきたいと思います。

まず「I 各規則制定の背景・経緯及びその後の主な改正点」ですが、特に重要視したのは、法的構成がどうなっているか、すなわちどの法令の根拠条文に基づいて制定されたのか、あるいは制定・改正にあたって特定の出来事がどのように関係しているのか等、可能な限り調査しました。最初に1のボイラー則ですが、「(1) 明治維新後から汽罐取締令の制定まで」の時期においては、殖産興業に基づいた急速な工業の発展がみられた中でボイラーも増えていきました。そのため、破裂事故も多発し、大きな社会問題となっていました。その典型例としては、浅田資料1頁に書いてあるような明治3年7月に鉄砲州（現在の東京都中央区湊）の波止場で発生した、アメリカの蒸気船の汽罐の破裂事故で、47人が死亡した大災害でした。ボイラーについては当初、明治30年の工場法第7条に「工場ニ汽罐ヲ設置セントスル者ハ當該官廳ニ届出デ検査ヲ受クルベシ。前項ノ検査ハ定期又ハ臨時ノ検査ニ合格セザル汽罐ハ之ヲ使用スルコトヲ得ズ。」との条文案があり、まさしくピンポイントでボイラーに関する規制案があったのですが、残念ながら中小事業者の強い反対があって法案提出に至りませんでした。工場法の中で強いて関連する規定を挙げるとすれば第13条で、行政官庁が危害防止のため必要な事項を工場主に命じることができるという命令委任の規定が設けられたのみでした。実際のボイラーの取締については、行政取締りの一般法である行政執行法に基づき、その施行令の第2条に、「汽罐、汽機及其ノ附属装置ニ就キ危害ヲ生ズル虞アリト認メタルトキハ行政官廳ハ其ノ使用ヲ制限スルコトヲ得」と規定されていました。さらにそれを受け、明治36年に内務省警保局長から各府県長官、現在の都道府県知事に対して「蒸気機関技術者取締に関する依命通達」が発出され、さらにそれを受けた形で、各府県の条例として取締規則が制定されていました。しかし、浅田資料2頁に書いたように、内容も概括的で府県ごとに規制も異なるなど大変不便だったため、関係団体から昭和6年に建議書が出されています。そこでは、「・・・各種汽罐、蒸罐の利用急増に伴い、依って生ずる災害亦多きを見るに至れり。（中略）然るにその取締の現状を見るに、未だ汽罐に対して、一定の規格標準なく・・・結果災害防止上遺憾の点多きのみならず、製作者並びに使用者の不利不便亦是少なからず。」よって速やかに適切な法令の制定を求めるとされていました。これを受けた形で汽罐取締令が昭和10年に制定され、施行されました。これに伴って汽罐構造規格が告示として制定されています。その内容は各根拠条文も含め、浅田資料3～4頁以下の枠内に記載しましたので、詳細についてはこれをご覧ください。現行の法令にもあるような規定が、すでにこの中に見受けられますが、各府県の条例である汽罐取締規則から汽罐取締令への主な変更のポイントとしては、浅田資料4頁(i)～(iv)に挙げた通りです。まず、「(i) 汽罐の検査を汽罐本体の罐体検査と汽罐設置状況の竣功検査に分離し、罐体検査に合格した汽罐の取引の安全が確保されるようになったこと」、「(ii) 汽罐の構造上の要件として全国統一的な規格を整備したことにより、取締の合理化と汽罐製造業者の負担軽減が図られたこと」、「(iii) 警視庁と大阪府にのみあった汽罐士の制度を全国に導入し、汽罐取扱いにおける人的資質の安全が確保されるようになったこと」、「(iv) 汽罐の検査、汽罐士の試験・免許に手数料の制度を導入することにより、検査係官の充実等取締りの体制の整備が図られるようになったこと」が挙げられます。(v)については誤りなので、削除したいと思います。このように、ほぼ現行法に近いフレームワークがこの時点で整備されたこととなります。

汽罐取締令は戦後も続きましたが、日本国憲法が新たに施行されたのに基づいて、労働基準法が施行されました。労働基準法の中のボイラー等の規制に関する根拠条文は、浅田資料5～6頁の枠内に記載しています。そして労基法に基づいて制定された旧労働安全衛生規則「第3章 安全装置」の第34条およ

び第37条、それと「特別安全基準」の「第1章 汽罐及び特殊汽罐」が制定され、昭和22年11月1日から施行されました。「汽罐」というのはもちろん現行のボイラーのことで、「特殊汽罐」は第1種圧力容器に相当します。その具体的内容は浅田資料6頁以下に記載したとおりです。この他、汽罐や特殊汽罐に該当しない破裂事故の危険性のある「内圧容器」についての規制もなされました。現行の第2種圧力容器に相当するものですが、汽罐に比べるとやや簡易な規制内容になっています。ボイラー等の規制について、汽罐取締令から旧労働安全衛生規則への主要な変更点としては、浅田資料8頁記載の(i)～(v)がポイントです。すなわち、「(i) 規制対象を汽罐のみから特殊汽罐（第1種圧力容器）及び内圧容器（第2種圧力容器）についても拡大したこと」、「(ii) 溶接検査を新たに導入したこと」、「(iii) 汽罐士（いわゆるボイラー技士）の制度に特級汽罐士を新たに追加したこと」、「(iv) 汽罐・特殊汽罐に備えるべき安全装置、計測装置その他付属装置の構造上の要件を新たに定めたこと」、「(v) 汽罐溶接士の制度を新たに導入したこと」です。

その後、単独のボイラー則が制定されることとなりますが、これについては浅田資料8頁最後の行以降で述べています。昭和34年に旧安衛則から分離独立した形でボイラー則が制定・施行されていますが、変更された点については9頁に記載したとおりです。たとえば、(ii)にあるように、すべてのボイラー・第一種圧力容器について製造認可の制度を導入したことが挙げられます。従来は、溶接によるものだけが認可対象でしたが、それ以外のものについても対象とされたわけです。また、(iii)に書いたとおり、貫流ボイラーについて一部規制を緩和した、あるいは(vii)ですが、付属品に関する構造要件は従来規則に規定されていましたが、それを構造規格に移す、また(x)のように小型ボイラー及び小型圧力容器に関する構造規格を整備し、使用者の義務としての構造要件維持義務の導入(vii)、あるいは(xi)にあるように、ボイラー技士免許の有効期間に関する規定が削除され、ボイラー溶接士免許の免許更新に関する規定が整備された、等の改正がなされています。

次に「(4) 労働安全衛生法に基づく「ボイラー及び圧力容器安全規則」の制定まで」(浅田資料10頁)に移ります。この間、昭和38年に大改正が行われています。また、構造規格についてもかなり大幅な改正がなされています。改正のポイントは、「(i) 大気圧における沸点を超える温度の液体を内部に保有する容器が第一種圧力容器として規制されることとなった」、「(ii) 貫流ボイラーは緩い規制となっていたが、汽水分離器を有する貫流ボイラーは破裂の危険性もあるので一定以上の大きさの汽水分離器を有する貫流ボイラーについては通常のボイラーと同じ規制を受けることとした」、「(iii) 二級ボイラー技士試験の実技試験（投炭操法）を廃止し、これに代えてボイラー実技講習の制度を導入した」、「(iv) ボイラー取扱主任者の職務に「自動制御装置の点検調整」を追加した」、「(v) ボイラー構造規格、圧力容器構造規格、小型ボイラー圧力容器構造規格については、日本工業規格の改正・制定に伴う整合性の確保、新しい型式のボイラー等に対する必要な規制の追加等に伴う改正を行った」、などです。昭和47年に労働安全衛生法が施行されると、それに基づく改正がなされています。ボイラー等の規制に係る根拠条文は、浅田資料10頁以降の枠内に列挙しています。旧ボイラー則についてはいったん廃止され、労働安全衛生法に基づいて新たにボイラー則が制定・施行されるという形をとりました。当然、旧規則の名宛人であった「使用者」は、「事業者」に変更され、これが改正の中心です。それ以外のポイントとしては、浅田資料17頁に記載したとおりです。すなわち、「(i) 第一種圧力容器取扱作業主任者の選任要件としての資格を定めたこと」、「(ii) 第一種圧力容器の整備の業務について、ボイラー整備士でなければ就業できなくなったこと」、「(iii) 小型ボイラーの取扱いの業務につかせるときの特別教育の制度を導入し、その科目等を定めたこ



と」、「(iv) 小型圧力容器について定期自主検査の制度を導入し、その実施時期、検査項目、記録の作成等を定めたこと」、「(v) ボイラー技士免許・ボイラー溶接士免許を受けた者が、すでに同種の下級の免許証を受けているときは、当該下級の免許証を都道府県労働基準局長に返還すべきことを定めたこと」、などです。

次に、「(5) 現行の「ボイラー及び圧力容器安全規則」まで」（浅田資料17頁）を簡潔に拾っていきたいと思います。細かい点は多々あるのですが、昭和63年の改正以降は規制緩和に関するものが挙げられます。昭和58年の行革の最終答申の指摘を踏まえ、溶接士免許の有効期間の延長がなされたほか、平成6年の行革大綱によって事故報告を安衛則に統合するなどといったものです。また、規制緩和推進計画に基づいて、平成10年には従来ボイラーとして規制されていた小規模温水ボイラーを小型ボイラーと位置付けた規制をするようになりました。一部、性能規定化に近い構造規格の見直しなども行われています。その他、最近の改正ですが、自動制御装置について機能安全に適合したものについては一部規制を緩和するとか、直近の改正としては安全帯が「要求性能墜落制止用器具」に改められています。

次にクレーン則に移ります（浅田資料19頁）。工場法には、クレーン等を規制する条文はありませんでしたが、労働者災害扶助法（昭和6・4・2法律54号）は基本的に土木建築労働者及び交通運輸労働者に対して業務上の傷病・死亡について補償義務を定めたもので、その第5条に「行政官庁ハ命令ノ定ムル所ニヨリ事業ノ行ハルル場所ニ於ケル危害ノ防止又ハ衛生ニ関シ必要ナル事項ヲ事業主又ハ労働者ニ命ズルコトヲ得」との定めがありました。これに基づいて、土石採取場安全及衛生規則が昭和9年に制定・施行されています。もう一つは、土木建築従事労働者の安全衛生を確保するための土木建築工事場安全及衛生規則が制定・施行されています。土石採取場安全及衛生規則が土石採取場のリフトについての規制、土木建築工事場安全及衛生規則がエレベーターの構造要件やデリック、リフト等の安全荷重等の規制をそれぞれ行っていたということです。規制の内容については、浅田資料20頁記載の枠内に主な規制の概要を示しました。土石採取場の②の巻揚装置は先ほど説明したとおりです。土木建築については、大きく分けて起重機（現行のクレーンに相当）に関する規制と揚重機（このうち昇降機は現行のエレベーターに相当）の規制とがありましたが、クレーンである起重機とエレベーターである昇降機とを合わせて「揚重機等」として規制を行っていました。巻揚装置というのは現行のデリックやリフトに相当するものです。そういうものに対して、様々な規制を行っていたということです。

「(2) 労働基準法に基づく労働安全衛生規則の制定まで」（浅田資料21頁）ですが、先ほども申しましたように、日本国憲法にもとづいて労働基準法が制定・施行され、それに基づく旧労働安全衛生規則が昭和22年に制定・施行されました。当時クレーン等に関する規制は、旧安衛則の「第3章 安全装置」の第34条、「特別安全基準」の「第2章 揚重機」に規定されていました。その概要は、浅田資料21頁以降の枠内に示す通りです。規制対象としては、「揚重機」すなわち現行の「クレーン」、「移動式クレーン」、「デリック」、「エレベーター」、「建設用リフト」、「簡易リフト」に相当するものです。その設置は所轄労基署長の認可を必要とし、③にあるように落成検査、④の性能検査・・・等が規定されています。⑦のとおり、構造要件についても若干の規定があります。戦前の諸規則から旧労働安全衛生規則への主な変更点は浅田資料23頁の(i)～(vi)に書いたとおりです。すなわち、「(i) 規制対象を土木建築工事場等のみから一般の工場その他すべての業種に拡大したこと」、「(ii) 揚重機の設置・変更について労働基準監督機関による認可制度を導入したこと」、「(iii) 揚重機の落成検査・性能検査・変更検査及び有効期間のある検査証の制度を導入したこと」、「(iv) 揚重機の構造上の要件を新たに定めたこと」、「(v)



揚重機の管理に関する規定を新たに定めたこと」、「(vi) 起重機運転士免許の制度を導入したこと」などといったところです。

次に、「(3) 労働基準法に基づく「クレーン等安全規則」の制定まで」ということで、まず昭和34年に玉掛けの技能講習制度が導入されました。次いで、クレーン等についてはいろいろあるのですが、昭和33年に総理府の審議機関である臨時産業災害防止懇談会が「産業災害防止対策に関する意見書」を提出しました。そこでは、「重大災害の頻発とその発生原因の実情にかんがみ急を要するもの、例えば、煙火爆発、崩壊、ボイラ及び压力容器、揚重機等について関係規則又は基準等を至急改正する」べき旨指摘されていました。それとともに、中央労働基準審議会の建議においても、「(旧) 労働安全衛生規則をみるに、施行後10年を経過しているため・・・必ずしも実情に即さないと認められる規定もなしとしないし、又補充を要する部分も少なくないので・・・検討整備を行う必要がある」旨述べられていました。それを受けて、旧安衛則から分離独立してクレーン等安全規則が昭和37年に制定・施行されています。改正のポイントは浅田資料24頁(i)～(ix)に記載したとおりです。小型の小能力のものも含めて規制対象とし、巻揚げ荷重3トン以上のクレーンと移動式クレーンはすべて製造認可の対象とし、また移動式クレーンは従来クレーンと同様落成検査の対象だったところ、製造検査のスタイルに変更しました(以上(i)～(iii))、等々です。免許関係では、(vi)にあるように、従前は起重機運転士免許を所持していればクレーン、移動式クレーンもデリックも運転できたのですが、デリックは別の免許となりました。また、玉掛技士免許も導入されるなど、全体的に大きな改正がなされています。(viii)にもあるように、構造要件は従来規則に定められていたところ、これを告示において定めるようになりました。

その後、「(3) 労働安全衛生法に基づく「クレーン等安全規則」の制定まで」にあるように、昭和47年の安衛法制定前の昭和46年にも大きな改正が行われています。クレーンの規制対象としてつり上げ荷重が1トン以上のスタッカー式クレーンを製造認可等の対象としたほか、荷重試験について定荷重での荷重試験とこれを超える過荷重試験の2種類を行っていたのですが、落成検査・製造検査・再使用検査・変更検査の荷重試験は過荷重試験、性能検査の荷重試験は定格荷重試験のみそれぞれ1種類の荷重試験を行う方式に改めています。また、過荷重の原則禁止、労働者の搭乗禁止なども追加されています。さらに、クレーン運転士免許はクレーン運転士免許と移動式クレーン運転士免許に分離され、玉掛け業務の就業制限の範囲が3トン以上から1トン以上に拡大されています(以上、浅田資料24～25頁・(i)～(v))。その他(vi)以降に記載したとおりです。翌年の昭和47年に労働安全衛生法が制定され、それに基づくクレーン則が新たに制定されました。ボイラー則と同様名宛人を使用者から事業者に変更したほか、浅田資料26頁(i)～(vi)に記載した通りの改正がなされています。すなわち、設置変更認可を届出制に改め(i)、小型のクレーン等の運転又はつり上げ荷重が1トン未満の玉掛けの業務につかせるときの特別教育制度の導入(iii)、作業指揮者の選任(iv)、(vi)のような実技講習制度が導入されています。

その後、現行のクレーン則までの経緯は浅田資料26頁「(4) 現行の「クレーン等安全規則」まで」に記載したとおりです。クレーンの構造規格が技術の進歩に対応して見直され、フックの外れ止め装置の使用が義務づけられ、そのほか26頁以下に記載したような改正がなされています。また、エレベーター構造規格についても技術の進歩や建築基準法との整合性確保のための改正がなされたほか、行革大綱に基づいて一部の設置報告が不要になり、ボイラーと同じような規制緩和の動きがみられます。

次にゴンドラ則に移りたいと思います(浅田資料30頁・「3 ゴンドラ安全規則(昭和47・9・30 労

働省令35号)」。ゴンドラは、もともと「つり足場及び昇降装置その他の装置並びにこれらに附属する物により構成され、当該つり足場の作業床が専用の昇降装置により上昇し、又は下降する装置」と定義されています。ビルの清掃作業等で多用され、昭和43年頃からゴンドラによる災害が発生するようになりましたが、当時は労働安全衛生規則のつり足場としての規制（浅田資料30頁（i）～（iv））にとどまっていた。しかし、昭和44年の渋谷のデパートでの窓拭き作業中にゴンドラが落下し作業員1名と歩道を歩いていた小学生2名が圧死するという悲惨な災害が発生しました。災害の発生原因としては、減速機（ギア）の調整不備によりかみ合わせが浅くなっていたため、ギアが外れて制動が利かずに落下してしまったということでした。この事故の5日後には、兜町のビルの外装清掃中のゴンドラが片づりになり、作業員2名が道路上に転落して死亡するという災害も発生しています。こうした重大災害の多発を契機として、労働省が全国で一斉監督指導を実施し災害の分析検討を行った結果、当時の旧安衛則では災害を防止するには不十分であったということでした。

こうした状況を踏まえて、新たにゴンドラ則が昭和45年から施行されたということ。ポイントは浅田資料31頁（i）～（vi）のとおりです。基本的にはクレーンに近い内容の規制で、たとえばあらかじめ行政官庁に認可を受けなければ製造・変更・設置ができない（i）、構造規格を定める（ii）、認可後1年経過後は性能検査に合格しなければならない（iii）、操作者の資格（iv）、点検義務（v）、下方への立入禁止措置（vi）、などといった内容です。これをさらに詳細に条文を明記しながら記載したのが浅田資料31頁の枠内ですので、後ほど各自ご覧になっていただければと思います。さらに、ゴンドラ則に基づいてゴンドラ構造規格が制定・施行されています。

そして、労働安全衛生法が昭和47年に制定され、それに基づくゴンドラ則が新たに制定されました（浅田資料32頁・「（3）労働安全衛生法に基づく「ゴンドラ安全規則」の制定まで」）。名宛人の変更についてはクレーン則等と同様です。主要な変更点は、浅田資料32頁（i）～（v）記載の通りです。検査証を都道府県労働局長が公布すること（i）、設置認可制度及び変更認可制度が届出制度になり（ii）、操作者について特別教育制度の対象となり（iii）、定期自主検査の制度が導入され（iv）、休止ゴンドラの再使用に際しては使用再開検査を受けなければならないこと（v）、などです。「（4）現行の「ゴンドラ安全規則」まで」（浅田資料33頁）はここにあるとおり、諸外国の構造規格との整合性の確保を図るなどといった趣旨から、平成6年に新たな構造規格が制定されました。その内容は浅田資料33頁以下（i）～（ix）のとおりです。

浅田資料35頁「II 労働安全衛生法及び労働安全衛生規則（昭和47・9・30労働省令32号）との関係」ですが、ボイラーやクレーンなどに関する現行の法令については、いずれも規制対象機械の製造に始まり、設置、使用、変更、休止、廃止等に至る基本的にすべての段階における規制が定められています。その根拠条文は浅田資料36頁以下の枠内に示した通りです。浅田資料44頁に労働安全衛生法の根拠条文と特別安全規則の各条文との対応関係、つまり特別安全規則の各条文が安衛法のどの条項に基づいているのかをまとめましたので、後ほどご覧いただければと思います。次に「2 労働安全衛生規則（昭和47・9・30労働省令32号）との関係」（浅田資料47頁）ですが、先ほど説明したとおり、特別安全規則はもともと安衛則から分離独立した規則なので、規制対象機械の規制を完結した形で規定しています。労働安全衛生規則を一般則とすると、特別安全規則はその特別規則の関係にあるといえます。ただし、一覽性確保という観点から、特別教育については安衛則第36条に、免許試験については安衛則第69条にそれぞれ特別安全規則に定めるものも含める形で網羅的に規定されています。

次に、「Ⅲ 各規則の基本構造・体系の共通性等」（浅田資料47頁）ですが、1・（1）の表題どおり、「規制対象機械の製造から、設置、使用、変更、休止、廃止等の各段階に至る一貫した規制」を行っています。こういう諸々の製造、届出、検査等の手続を踏ませることによって安全の確保を図る仕組みになっています。これは、検査対象機械のリスクに重大な変更が生じる場面で行政や第三者機関による許可、届出、検査等を通じて安全確認を行うという仕組みです。それぞれの規制のフローチャートを浅田資料48頁以下に示しました。特徴としては、「（2） 規制対象機械のリスクに応じた規制」になっています。リスクの高低に応じて規制の強弱を設定する仕組みということで、最もリスクの高いもの（ボイラー、クレーン等）は特定機械として位置付けて製造許可や就業制限、使用時の安全措置等のフルスペックの規制を行っています。次にリスクの高い機械（小型ボイラー、第二種圧力容器等）については、個別検定、定期自主検査、特別教育等の規制を行っています。リスクの低い簡易ボイラーや小規模のクレーン等については、構造規格の具備を義務付け、具備しないものの譲渡・貸与・設置・使用の禁止等一定の安全措置等の規制で対応しているということです。（3）にあるように、「規制対象機械による災害を防止するため、物的規制、人的規制及び管理的規制からなる総合的規制」を行っています。物的規制としては、製造許可、設置・変更届等があり、人的規制としては就業制限、特別教育の受講等があり、管理的規制としては、作業主任者による管理等があります。

「2 特別安全規則の見直しの提言」（浅田資料51頁）をまとめてみました。以上説明させていただいたとおり、特別安全規則には一定の共通性がみられます。ただし、主なハザードが破裂・爆発等である熱機関としてボイラー等に対する規制と、主なハザードが損壊・転倒等の動力運搬機関であるクレーン等に対する規制は、その内容、方法等が大きく異なるため、両者を統合して1つの規則にまとめるのは、適切ではないと考えられ、別立ての規制にした方がいいでしょう。ただ、クレーン則とゴンドラ則については、ハザード面でも共通しているので、統合は十分可能です。具体的には、クレーン等安全規則にゴンドラの章を新たに追加することで対応できると考えられます。ゴンドラについては、常設型のゴンドラと可搬型のゴンドラとに大きく使用形態が分かれているので、常設型については現行のクレーンと同様に据付状況を確認できる落成検査の方式に移行するのが妥当であろうと考えられます。

次は「Ⅳ 定義・範囲」（浅田資料52頁）ですが、ここに記載した根拠条文ほぼそのままの内容です。ボイラーとはそもそも何かということなのですが、52頁「② 適用範囲と規制」に記載したとおり、3つの要件すなわち「（i）火気、高温ガス又は電気を熱源とするもの」、「（ii）水又は熱媒を加熱して蒸気又は温水を作る装置であること」、「（iii）蒸気又は温水を他に供給する装置であること」を充たすもので、これが基本的な定義です。そして、蒸気ボイラーと温水ボイラーがそれぞれどの範囲まで含むのかについても記載しました。これについては、先にも申しました通り、最も厳しいフルスペックの規制が施されています。小型ボイラーについての定義は「（2） 小型ボイラー」（浅田資料53頁）に記載したとおりです。「② 適用範囲と規制」ですが、小型ボイラーは、ボイラーのうち低圧・小型のものなので、リスクが低く、ボイラーに比べると規制が緩くなっている、その内容は浅田資料53頁最後の行以下に記載したとおりです。「（3） 簡易ボイラー」（浅田資料54頁）については、小型ボイラーよりもさらに危険性が低いため、一層規制が緩くなっています。「（4） 第一種圧力容器（労働安全衛生法施行令第1条第5号）」（浅田資料55頁）の法令上の定義は①記載通りです。「② 適用範囲と規制」については、「火なし圧力容器」と呼ばれるものです。要するに、大気圧における沸点を超える温度の液体を内部に有する容器のことを指しているため、ボイラーと同じように破裂の危険を有しています。規制内容もボイ



ラーに準じた最も厳しい規制が施されています。「(5) 小型圧力容器」(浅田資料56頁)は第一種圧力容器のうち低圧・小型のもので、少々緩い規制になっています。「(6) 第二種圧力容器」(浅田資料56頁)については、内部に圧縮気体を保有するものということで、仮に容器に欠陥があつて開口部を生じて、内部の気体が急激に噴出する程度にとどまるので、リスクは低いものであるため、小型ボイラー並みの規制にとどまっています。最も規制が緩いのは「(7) (簡易)容器」(浅田資料57頁)で、通常「容器」と呼ばれています。これは、第一種圧力容器のうち、最も小型で低圧のものということです。

「(8) 伝熱面積」(浅田資料58頁)によって規制が変わってきますが、その定義は記載したとおりです。

次にクレーンについては、「2 クレーン等安全規則」(浅田資料59頁)にありますように、定義については労働安全衛生法が施行された際の施行通達の中に規定されています。そして、適用範囲や構造要件などは記載の通りになっていますので、後ほどご一読いただければと思います。「(2) 移動式クレーン」(浅田資料60頁)、「(3) デリック」(浅田資料61頁)などもまた同様で、危険性が高いので特定機械等として厳しい規制を受けます。「(4) エレベーター」(浅田資料62頁)についても同様です。ただ、エレベーターは特定の業種(労働基準法別表第1第1号から第5号まで:製造業、鉱業、建設業、運送業、貨物取扱業)の事業場に設置されるものに限るとされています。エレベーターは人などを乗せて上昇・下降する装置なので、不具合により甚大な被害を生じ得る極めて危険性の高い装置であるため、特定機械等として規制されています。「(5) 建設用リフト」は浅田資料64頁記載の通りで、危険性が高いゆえに規制を受けています。「(6) 簡易リフト」(浅田資料64頁)は、エレベーターのうち荷のみを運搬することを目的とする搬器の大きさが小さいものです。危険性が低いということで、別途緩い規制がなされています。「(7) つり上げ荷重」「(8) 積載荷重」(いずれも浅田資料65頁)はここに記載したとおりです。ゴンドラについては先ほど申しました通り、危険性が極めて高いということで、特定機械等としての規制を受けています(「3 ゴンドラ安全規則」(浅田資料65頁))。

「V 適用の対象、適用の除外・特例・例外等」(浅田資料67頁)についてですが、適用対象は先に述べた通りです。ボイラーの適用除外はここに記載したとおり、労働安全衛生法施行令第12条第1号に定められていますが、「小型ボイラー並びに船舶安全法(昭和8年法律第11号)の適用を受ける船舶に用いられるもの及び電気事業法(昭和39年法律第170号)の適用を受けるもの」が適用除外され、小型ボイラーにおいても同じく「船舶安全法の適用を受ける船舶に用いられるもの及び電気事業法の適用を受けるもの」が適用除外とされています。クレーンについては、「2 クレーン等安全規則」(浅田資料68頁)にありますように、他法の適用の結果適用除外となるものはなく、つり上げ荷重によってレベルが異なってきます。移動式クレーンやデリックもまた然りです。エレベーターについては先ほども述べた通り、特定の業種に限定され、それ以外のものと一般公衆用については建築基準法によって規制されています。建設用リフト、簡易リフトもまた然り、です。ゴンドラについては適用除外はなく、すべて積載荷重如何に関わらず、ゴンドラの定義に該当するものはいずれも規制対象とされています(「3 ゴンドラ安全規則」(浅田資料70頁))。

以上、ご清聴ありがとうございました。

三柴 非常に詳細にまとめていただいております。他方で、事務系にも分かり易いという趣旨で体系書を作りたいということなので、用語の解説についてももう少しベタベタ貼り付けていただく必

要があると思います。他の解説者が担当する章の解説で写真や絵がついているのはいいと思うのですが、それでもなるべく独自に、たとえば「パワーリフト」「ロングスパン建設用リフト」などについて、“サルでもわかるように” 絵図を用いた解説があるとよりよくなると思います。それにしても、実に緻密に丹念に整理をしていただいて本当にありがたい限りです。沿革も丹念に調べられていて、どういう経緯で今の形になったのかよく伝わってきます。

いったん休憩を入れまして、衛生関係の特別規則についてもご報告をいただいたうえで、まとめてご質問いただくということにしたいと思います。



三柴 再開させていただきます。先ほどの浅田先生のご報告から安衛法の特徴がよくわかる面があります。というのも、今までの安衛法は技術的な立法であったと思います。あえて厳しい言い方をすると、設計図や使い方を記載したマニュアルをそのまま法令にするという感じで、特定の基準を定め、箸の上げ下げまで指定することで労災の防止を図るようなものです。そのような特徴を指摘できると思います。それゆえに、事務系・文系の人たちがとっつきにくくなってしまいうわけです。いろいろと細かい仕様はあるのですが、核心は何なのか、要点は何なのか、思想は何なのか、趣旨は何なのか、技術系の方が分かり易く解説してくれることで、事務系の人々の理解がより一層深まるのではないかと思います。現在私が参与している化学物質管理の検討にも言えることなのですが、やはり技術に詳しい人が論じると、話がどんどん細かくなっていきます。誠実で丹念な解説ですが、それゆえに文系の人についてはついていけなくなってしまいうという事態が起きてしまいます。なので、法の体系として原則を法令に定め、詳細はガイドライン等に落としていくなどといった整理の仕方も重要だし、また原則部分には趣旨が明確に表れるようにしてゆくことも必要かと思えます。ということで、細かい知識を丹念に洗っていく作業と、そのエッセンスを明確にし、歴史・沿革を検討するのであればどういうラインどりで展開してきたかが明確にすべきかと思えます。

では、藤森先生、ご報告お願いいたします。

藤森 私の方からは「労働衛生関係の特別規則の趣旨と概要、統合の可能性」というテーマで報告させていただきます。前回もこのテーマに関して私なりの4つの視点ないし骨組みを報告させていただきました。それが共有画面に表示されている資料（※「労働衛生関係の特別規則の趣旨と概要、統合の可能性」、以下「藤森資料」とする）の「1 制定の背景・経緯及びその後の主な改正点について」です。その下には「2 労働安全衛生法及び労働安全衛生規則との関係について」、3番目は「3 各規則の基本構造・体系・構成の共通性について」、次に「4 定義・適用の対象・範囲等について」、ここでは適用除外や特例など衛生関係規則に相当数みられる規定について考察しようとするものです。ということで、前回骨組みを報告しましたが、今なお未完成ではありますが、簡単に説明させていただき、ご意見等いただければ幸いです。

まず「1 制定の背景・経緯及びその後の主な改正点について」とは、藤森資料2頁に列挙した規則についてのものです。なお、前回畠中先生からのご指摘により、「事務所衛生基準規則」は対象から除外して、合計で10について言及します。一番目の「制定の背景・経緯及びその後の主な改正点について」は悩みどころが大きく分けて二つありまして、まずどこまで深掘りすべきかということです。私としては制定当初の立法経緯や趣旨はもちろん、その後の社会のニーズに基づく改正についても挙げました。一例を挙げると、藤森資料4頁の有機溶剤中毒予防規則に関する記述ですが、その冒頭に「1 制定の背景・経緯及びその後の主な改正点」ということで、制定当初だけでなくその後の有機規則の改正等も含めて記載したつもりです。先ほど安衛法関係のご説明がありましたが、安衛法は昭和47年に制定されていますが、それに基づく規則がほとんどです。実は安衛法制定前から施行されていた規則があり、たとえば電離放射線障害防止規則などは昭和34年からありました。戦後間もない頃、電離放射線物質が輸入されたことによるニーズもあり、そうした事情をどの辺りまで深掘りすべきかということですが、先ほども言ったように基本的には、労働安全衛生法に基づいた規則という意味で、昭和47年以降をベースにしているところです。これについてご意見ございましたらぜひお願いいたします。もう一つは、労働安全

衛生法と労働安全衛生規則との関係についてですが、これについては藤森資料2頁の安衛法第22条をご覧いただきたいのですが、第20条以下に事業者の措置義務に関する規定があり、その中でも健康障害防止については第22条、場合によっては第23条が問題となってきます。それについてもどんな体系・構造になっているか図説したのが藤森資料3頁の図1です。様々な現場の要因に基づいて、どのような健康障害が生じるおそれがあり、それについてどのような措置を講じるべきかを骨組みとして示しています。これに基づいて、図の中に小さな文字で記載していますが、各規則が制定されています。先ほどの悩みどころのもう一つは、タイトルにあるように、「統合の可能性」という命題について私なりに悩みまして、結局それはどういうことだろうかということです。統一性のことなのか、あるいは共通性のことなのか、あるいはまた違った観点なのか・・・私の結論としては統一性・統合性、あるいは共通性と言いましょうか、そんな感じのことが必要ではないかと思います。三柴先生が前回ご指摘されたのは、現行の規則は膨大な数に発展したのはいいとして、“規則に書かれていないことは実施しなくてもいい”という誤解が生じるのではないかと、原理原則を踏まえて、規則に書かれている内容に縛られない解釈が必要であると、そのようなことをご指摘されたと思います。そのような観点から、法令の適用を受け法令を用いる事業者にとって分かりやすくアクセスしやすい共通性を見出せないかということで、10の規則を検討したいとおもいます。結局それは、人、物、作業、管理という切り口から検討することになります。たとえば教育、設備、作業主任者など、そういった様々な規制の中に一つの共通性が見いだされ、そこに一つの共通の規定のし方があれば、分かりやすくアクセスしやすくなるのではないかと思います。先ほど唐沢先生のご報告で扱われた諸外国の現状について私は不案内なもので、またご教授いただきたいと思いますが、化学物質ごとに統一・統合された観点はあまり見受けられないのではないかと感じていたので、その辺りのことも含めどのように検討すべきかを悩んでおります。

共通性という場合にやはり重要なのは、藤森資料2頁「表1 疾病の種類と対策の関係」をご覧ください。分類としては、「職業性疾病」、「作業関連疾患」、「私傷病」に分かれます。作業関連疾患とは、作業と何らかの関連性がある疾患、あるいはもともとは私傷病でありながら業務が原因で増悪したものに分けられる疾患です。「労働衛生の三管理」、すなわち「作業環境管理」、「作業管理」及び「健康管理」というものがあり、それぞれの疾病に対する切り口となります。各規則もまた、必ずしも図式通りになっていないにせよ、そのような観点から整理分類ができるのではないかと思います。そのような基本的な観点のもとに各規則があると思います。この点、どちらかと言えば、藤森資料2頁に列挙した規則のうち、②以下の特別規則ではなく、労働安全衛生規則にも「第三編 衛生基準」があり、ここにはダイオキシンの規定があり、他の特別規則ではなく安衛規則において規定されているところです。規則の中に一般法（一般規定）と特別法（特別規定）があるという見方もできるのかどうかについても一応言及したつもりです。そのほか、各規則一つ一つについて、制定の背景・経緯、主な改正点、特に改正については一応概観したつもりですが、まだ詳細に踏み込んだわけではないので、ご意見をいただければと思います。

各規則につき「構成」を記載しましたが、これは先ほど言った労働衛生の三管理、あるいは人・物・作業・管理という観点から、受け手に分かりやすく体系立てて言及できればと考えています。「定義・適用のル対象・範囲等について」という問題もありますが、最低限の定義は書きます。例えば有機溶剤と一口に言っても400種類ほどあるにもかかわらず、有機溶剤中毒予防規則における対象有機溶剤は44種に絞られ、それはなぜなのか、当該法令や規則に特化した定義があるということです。酸欠則においても同様です。言葉の定義がきちっとしていないとややこしいことになってきますが、この辺についても言及

したいと思います。また、定義と同時に重要なのは適用範囲であり、「業務によって」あるいは「作業によって」事業者としてしなければならないという縦軸について、横軸の業務・作業は何か、他にも「物質によって」「場所によって」「消費量によって」「時間によって」・・・これらは曝露量の問題です。あるいは「設備等によって」範囲が決まってくる、あるいはそれに伴って適用除外や特例の有無が決まってきます。そういう仕組みになっているということも言及します。有機則あたりは適用関係は書いていますが、それ以外の規制についてもそのような観点からコメントできればと思っています。特化則は、最近の改正についても言及するつもりです。

電離放射線規則は歴史的にはかなり古くからあります。酸欠則においては、まず場所を決めてそこで行う作業が規制の対象となりますので、それをめぐって数値が決まってきます。その辺りまで言及できればと思います。粉じん則においては、「粉じん作業」と「特定粉じん作業」とに区別され、これに従って事業者として講ずべき措置はどのようなものか、いまのところ藤森資料では空白になっていますが、整理してみたいと思います。石綿についてはごく最近改正されたものがありますが、その辺についても限られた範囲の中で取り上げるべきかと思っています。以上と除染則をあわせて合計10に及ぶ規則、場合によっては安衛則の検討も盛り込んで完成させたいと考えています。

短時間で非常に雑駁ではありますが、以上でございます。

三柴 ありがとうございます。藤森先生の途中経過をご報告いただいたわけですが、やはりまとめられる先生によって個性が表れると感じます。藤森先生は管理のお立場を意識しながら業務にあたってこられたことを感じさせるご報告で、整理統合をすると要点は何なのかについてよく意識してまとめているものと思われまます。先生方から何かご質問ございましたらよろしくお願ひします。

畠中 お二方とも非常に細かくまとめておられて、私としてもこのような文書は初めて見るもので、これが完成したら非常に有益なものになると思います。ただ、総論的なお話になるのですが、浅田先生のボイラーの取締に関する最初の部分において、汽罐取締令が工場法第13条に基づいて制定されたという記載がありますが、これは誤りではないかと思ひます。参考ですが、汽罐の取締に関して私の手元に岡實先生が書かれた工場法論、これは工場法施行の翌年である大正6年に書かれた計1200頁ほどの本ですが、同書を見ると各都道府県で汽罐の取締が相当数行われておりまして、一番最初は明治16年の福岡県、明治19年の長野県ということで、大正6年までの間に「汽罐機器の取締に関する規則は各府県あまねくこれを設く、最初にこの種の取締規則を設けたるは、」・・・ここでは長野と書いてありますが、別の資料では福岡となっています・・・「明治16年長野にして、東京明治27年がこれに次ぐ。その他の和歌山、静岡、大分、鳥取など発布せられたり。」というような感じで、大正6年までの間に5県以外のほとんどの都道府県で施行されている旨書かれています。浅田先生の書かれた中でもう一点、行政執行法に基づいて汽罐機器の取締りが行なわれ、各府県における汽罐機器の取締令が作られてきた旨書かれています。これも書き方としてはどうでしょうか。行政執行法というのは、戦前のことですから戦後のように行政代執行以外許されないということではなく、直接強制なども同法に定められていたわけですが、直接強制の対象の一つとして危険なものということでボイラーが挙げられていた、要するに、ボイラーは行政執行法に基づく権限発動の対象になっていたに過ぎなかったのではないかと思ひます。この辺りの書き方は少々工夫されてはいかがでしょうか。

浅田 ありがとうございます。戦前の根拠条文については、畠中先生のご指摘を受け止め、もう一度精査してみたいと思います。私が参考にした資料の中に、内務省事務官等による「汽罐取締令解説」というのがあり、この中にも行政執行法第4条、同法施行令第2条の規定により、各府県において取締規則を設けることによって取締りを行ってきたという記載がありますので、もう少し精査してみたいと思います。

三柴 現行の法令であっても、ある省令がどの根拠条文に基づいているのか今一つはつきりしないものがあります。個人情報保護法でも、ガイドライン等がどの条文に基づいているのか分からないものがあったり、安衛法でも実施省令的なものがあり、紐づく条文がどれなのかよく分からないものも時々見受けられます。戦前のものであればなおさら根拠条文の調査は難しい面があると思いますが、趣旨をたどりながら言及していただければと思います。また、“参考文献としてこのようなものがある”などと記載していただくとか、あるいは“解釈としてこのように考えられる”など、語尾をややソフトにさせていただくといった書き方の工夫もあり得ると思います。

他にご質問は？

北岡 浅田先生にお尋ねしたいのですが、戦前の規制のあり方としては行政命令でボイラー等につき様々な規制を設けているわけですが、直接使用者を規制するものではなく、行政官庁が行政命令を発するための根拠ないし準則としての性質を有しているのでしょうか。私が何をお尋ねしたいかというのと、戦前においては行政官庁が行政命令を離れて事業者に対して指導を行い、これに従わない場合においては刑事罰等を科す余地があったかどうかです。法文上はあり得るかもしれないという気はするのですが、この点何か参考になるものがあればご教示いただきたいのですが。

浅田 汽罐取締令の中に罰則規定があり、“第〇条に違反した場合には科料を科す”ないし“拘留する”といった規定があります。やはり可罰のための根拠規定がないと、法治国家たり得ないと思います。

北岡 それは、何に対する罰則規定でしょうか。

浅田 汽罐取締令の条文に対する違反について、あるいは臨検の拒否等について、罰金、科料等が定められ、汽罐取締令に設けられた可罰のための根拠条文となっています。

北岡 安全衛生基準そのものに対する罰則もあったということですね。

浅田 そうです。それ以外にも、たとえば汽罐を設置しようとする者は地方長官の許可を受けなければならないとする規定に違反した場合の可罰規定などもあります。

北岡 ありがとうございます。

三柴 そうすると、法律の執行のマニュアル的なものとしての例があったというより、例自体が独立し



た法律に近い存在だったという理解でよろしいわけですね。

浅田 そうですね、現在であれば可罰の根拠は法律に根拠がないと罪刑法定主義に反しますが、戦前においては汽罐取締令のような内務省令の中にも可罰の根拠規定があったということです。

三柴 比較法的に大きくみると、イギリスは法律本文で曖昧な規定にも罰則を設けておいて、それを詳細化・具体化する規則が制定されている状況で、ドイツでは法律本法には罰則を定めず、規則の中に罰則を明記するという形で、両者とも安全衛生の問題にアプローチしています。私が調べてもそうだったし、吉川さんが調べてくれた、今の安衛法をつくる前段階で実施された調査の中でも言及されています。国によって法体系が異なるということも言えるし、同一の国の中でも歴史の中で法体系が変わってきているということも言えるし、それらを踏まえて将来的にどうするのか、その辺りも興味深いお話です。

森 藤森先生にご教授いただきたいのですが、現在衛生管理の流れとしては、リスクに基づいて管理していこうという方向に向かい、数多くある化学物質のうち特別管理物質に関してはリスクが低くても様々な措置を講じなければならないというルールが、自律管理の足かせとなっているのではないかと議論があります。今後化学物質の管理については、作業環境が適切に管理されている場所であれば多少は特殊健診を減らしてもいいのではないかと議論がなされています。では、物理的因子など化学物質以外の特別衛生規則に関しても同様の状況は生じないでしょうか。すなわち、ルールを細かく定め過ぎていくがゆえに、さほど健康障害が生じないレベルの状況にあっても、数多くの措置を講じなければならないという規定が存在し、その結果本来リスクマネジメントは優先順位を決めて高い順から実施していかなければならないのに、優先順位が逆転してしまい、本来最も優先的になされるべき措置が実施されなくなることが大きな問題となります。私は物理的因子にかかる衛生規則はさほど詳しくないのですが、化学物質に関して生じ得る問題が同様に懸念されるのかどうか、ご見解をお教えいただければと思います。

藤森 端的に申しますと、先ほどの議論からしても、そもそもリスクアセスメント自体が、「事業者は、厚生労働省令で定めるところにより・・・危険性又は有害性等・・・を調査し、その結果に基づいて、この法律又はこれに基づく命令の規定による措置を講ずるほか・・・必要な措置を講ずるように努めなければならない」（安衛法第28条の2）とされていますので、努力義務規定や罪刑法定主義の問題とも絡んできます。それはそれとして、放射線、高温、低温、騒音といった物理的因子の問題ですが、作業関連疾患等に関する規制がどうなっているのか、現在調べているところです。その点では化学物質や有機溶剤とは若干異なっているのではないかと思います。法令上の規制に関しても、特別規則が存在するものと、安衛則の中の規定で処理しているものがあるようです。

森 医療機関における電離放射線の新しい線量限度の適用の話の中で、均等被曝と不均等被曝のモニタリングを両方しないと被曝の管理ができないのかという議論があります。専門家とお話すると、プロテクタの中だけでやれば曝露量がわかるはずなのに、両方やれというのが法令上の要請だということで、放射線対策室ではいつも議論になります。あまりにも細かい規定があると、本来労働者の健康を守るた



めに必要最低限プラスアルファを求めてしまうという方向になってしまうという状況が、おそらく他の分野でもあり得るのではないかという認識から質問させていただいた次第です。

藤森 前回三柴先生も仰ったように、詳細な規則が充実化することは結構なのですが、だからといって規則に書かれていないことは実施しなくてもいいのかという問題が出てきます。その辺りは今後も検討を要すると思います。

三柴 この後北岡先生に罪刑法定主義のお話をさせていただきますが、結局法律家の頭では、災害を防止するためには丁寧な規制を細かく施していくという考えが基本になってしまいます。同時にそれは技術者の発想でもあると思います。技術者が必要と判断した再発防止策をそのまま特定の基準として細かいルールを次々に設けていくと、森先生がご指摘のように、現場では優先順位のない形式的な法適用が起きてしまうという問題が出てきます。様々な規定がある中で、何から実施していけばいいのか、また現場の実態に即したリスクに対応するにはどうしたらいいのか、といったことが見えづらくなるという問題もあります。では、細かいルールを完璧に遵守していればリスクを全て防げるのかといえば、そうでもなく、ちぐはぐな結果になってしまいます。これをどう防ぐかがリスク管理を生業とする安全衛生の重要な課題だと思います。私としては、先ほど申し上げたような提案はあるのですが、それはそれでなかなか難しかったりするので、知恵を出し合っていきたいところです。

畠中 先ほどの汽罐取締令に関する北岡さんのお話に関連するのですが、あれについて私は、明治憲法第9条の独立命令であると考えます。同条の文言をみると、「天皇ハ法律ヲ執行スル為ニ又ハ公共ノ安寧秩序ヲ保持シ及臣民ノ幸福ヲ増進スル為ニ必要ナル命令ヲ発シ又ハ発セシム（以下略）」とあります。天皇が自ら発する場合は「勅令」といいますが、「発セシム」というのは各省庁の省令、また都道府県の府県令がこれに含まれるということは、美濃部達吉先生の憲法学の本に書かれています。明治憲法の第23条（日本臣民ハ法律ニ依ルニ非スシテ逮捕監禁審問処罰ヲ受クルコトナシ）には罪刑法定主義が定められていますが、ある意味この特例でもあり、第9条の命令には独自に罰則をつけることができるようになっているという解釈のもとに、明治憲法の施行と同時に出された「命令ノ条項違犯ニ関スル罰則ノ件」（明治23年法律第84号）、そして同日に公布された「省令庁令府県令及警察令ニ関スル罰則ノ件」（明治23年勅令208号）などにより、一定限度の範囲内で・・・たとえば省令でつけられる罰則の限度は200円以内の罰金若しくは科料または3カ月以下の懲役・禁固・・・省令に独自に罰則を設けることができました。現行憲法の体系からすれば驚くような規定かもしれませんが、こういう仕組みがあったために、各省庁は独立命令という形で汽罐取締令などを制定施行していたわけです。

三柴 ありがとうございます。それでは、MLでは次に大藪先生のご報告を予定していましたが、話のつながりからすると、先に北岡さんにご報告いただいた方がよろしいかと思っておりますので、お願いいたします。

北岡 それでは、始めさせていただきます。「罪刑法定主義と安全衛生確保の関係」というテーマで報告させていただきます。内容としては、資料2頁（以下「北岡資料」とする）に記載したように、罪刑法定

主義の観点から、労働安全衛生法・政省令における危害防止基準の現状と課題について、若干の紹介を行います。寺西元検事および安西弁護士の文献を中心にご紹介させていただきたいと思います。その上で、今後ぜひご教示いただきたい点として、現在各先生方が担当条文について詳細な検討をされていると思いますが、本日はご紹介するような罪刑法定主義の観点から各規定・施行規則についてどのような課題があるのか、またないのか、ある条項や施行規則あるいは行政解釈について課題があるとすれば、ぜひご教示いただくと幸いです。もう一点は三柴先生からの宿題なのですが、イギリスの労働安全衛生施策との比較について検討する予定なので、この点につきましてもお詳しい方がいらしたら、ご教示いただければと思います。

では、まず北岡資料3頁をご覧ください。「罪刑法定主義」とは、法定手続の保障を定めた憲法第31条に基づく法規範をベースとするものであり、どのような行為が犯罪となるか、その犯罪に対してどのような刑罰が科せられるかということ、あらかじめ法律で明確にしていなければ、ある行為を犯罪としたり、刑罰を科することは許されないという刑罰法規に関する原理のことをいいます。そして、「罪刑法定主義から見た安衛法上の課題」（北岡資料4頁）とはどのようなものかを考えてみると、大きく分けて2点あると思います。一つは、政省令への委任の問題になりますが、安衛法はその危害防止基準の多くを安衛法その他の施行規則に委任しているわけですが、委任方法自体が罪刑法定主義に反する可能性はないのかということです。つまり、白地委任をしているのではないのかという論点です。二つ目には、仮に委任に問題はないとしても、安衛法および政省令に定める構成要件とその適用実態が罪刑法定主義に反していないか否かという問題です。具体的には、さらに二つのポイントがあるのですが、1) 安衛法が政省令に委任をし政省令が委任規定を設けるわけですが、その委任規定が安衛法の委任の範囲を超えている、2) 政省令への委任はいいとしてもそれに関する行政解釈が安衛法の解釈を明らかに超えている、これら2点が罪刑法定主義に照らして問題となり得るのではないのかということです。

まず、安衛法において包括委任規定が見受けられるわけですが、これについて少々整理すると、寺西元検事はこう述べています。すなわち、安衛法の政省令委任の根拠法令は4つあるということで、1つは「安衛法の本条に犯罪の構成要件が明示されている例」。一例として、「1つの貨物で、重量が1トン以上のものを発送しようとする者は、見やすく、かつ、容易に消滅しない方法で。当該貨物にその重量を表示しなければならない」（法第35条）という規定がありますが、これは政省令に委任していませんので、全く問題ありません。二つ目は、「規定の内容の一部を個別的に政令等に委任している例」。たとえば、「政令で定める規模の事業場」に対して衛生管理者の選任を義務付ける等、これについても寺西先生は問題ないだろうと述べています。三つ目ですが、「規定の内容の一部を包括的に政令等に委任している例」です。典型例として法第20条「事業者は、次の危険を防止するため必要な措置を講じなければならない。一 機械、器具その他の設備・・・による危険（以下略）」といった定めが置かれ、これに基づいて膨大な安全衛生規則が定められているということになります。

こうした包括委任規定についてどのように考えるのか、寺西先生はこの点あまり名言はしていません。様々な文献からすると、寺西先生は批判的な意見をお持ちのような印象を受けますが、明確にこれを否定しているわけではありません。この点をクリアに書いているのが安西弁護士で、安西愈『労働災害と企業の刑事責任』（労働調査会、2013）59頁以下の中で、以下のような説明をしています。「安衛法の場合には、社会の変化や技術・生産方式その他の化学技術や工法等の進展に対応して危険防止措置も変化していくものであるから、このような白地規定となるのはその目的上やむを得ない必然的なもの」で

ある、これを認めないと安西先生の表現によれば、安衛法は「電話帳」になり下がってしまう、といったように非常に巧みな表現で包括委任規定についてその適法性を説明しています。他方、安西先生は同時に、「一方で、政省令は当然に「法律の委任に基づくもの」でなければならない旨強調した上で、「刑罰という厳しい制裁を科す以上、どういう行為が犯罪となるのか、その行為にどういう刑罰が科されるのか」ということを事前に明確にしておかなければ、その法律の適用を受ける国民が自らの行為を法律に従って規律することができない。この罪刑法定主義の原則は安衛法のような行政法規についても刑罰権である以上同じ理が当てはまることになるのである」とされ、無制約な委任立法化に対しては強く警鐘を鳴らしています。このように、包括委任規定については認められるとしても、他方で委任の範囲を超えた労働省令というものが問題となります。

これについて寺西先生は、「安衛法14条と安衛則17条の関係」を指摘しています。現行規定も北岡資料8頁記載のものとは変わらないのですが、安衛法第14条は「事業者は・・・作業主任者を選任し、その者に当該作業に従事する労働者の指揮その他の厚生労働省令で定める事項を行わせなければならない。」と定めています。そして安衛則の中では「事業者は・・・当該作業に係る作業主任者を二人以上選任したときは、それぞれの作業主任者の職務の分担を定めなければならない」（安衛則第17条）としています。寺西先生は安衛法第14条が安衛則第17条に委任して、罰則を付している形になっているものの、安衛則第17条は安衛法第14条に根拠づけられないのではないかと、罰則適用しようとしても罪刑法定主義に反し無罪の可能性があると、厳しい指摘をしています。このような本法と施行規則の関係で、法を超えた施行規則の制定がこの他に見受けられるかどうか、別途検討課題になり得ると思われま。

次に、委任立法の行政解釈についてです（北岡資料9頁）。刑罰法規の解釈については、罪刑法定主義の原則に服しますので、文理解釈つまり法文に沿った解釈、そして拡張解釈は許容されます。拡張解釈とは、法文の文言に照らして最低限その文言に即して解釈することです。よく基本書の例として挙げられるのが、馬が引いている馬車に関して、「馬車が認められるのであれば、ロバが引いた荷台も拡張解釈上許容される」というものです。これに対して、たとえば“牛”といったように、まったく異なるものについても認められるのかということ、類推解釈に当たるために許されない、などといったことが初学者向けの教科書に書かれています。安衛法の解釈にもこの原則が適用されます。寺西先生はその顕著な例として、安衛則第269条を例に挙げています。すなわち、同施行規則は事業者に対し「化学設備又はその配管のうち危険物等が接触する部分について、当該部分の著しい腐食による爆発又は火災を防止するため、腐食しにくい材料で造り、内張りを施す等の措置」を講じることを罰則付きで義務付けています。これについての行政解釈（昭和42.2.6基発第122号）は、「等」の措置例として以下のような例を示しています。「構成部分の耐用期間を適切に定め、その期間毎にその部分を取り換えることが含まれる」と。寺西先生は、当該通達が法・施行規則で「例示されたものと異質な措置を義務付けることになる」としています。この施行規則はメンテナンスまで規定していないことは明らかではないかということです。腐食しにくい材料等で内張りを施す「等」の措置と書いてある以上、メンテナンスは行政解釈の内容を超えた解釈ではないかということです。他方で「その期間毎にその部分を取り換える」ことは、最低基準としての例示ではなく、防食塗料の塗布等の措置が許容範囲内であったか否かの判断基準になり得るという整理をしています。行為規範というよりは、防止措置が適切かどうかということです。つまり、腐食しにくい材料で造ったかどうかを判定するに当たってメンテナンスをしていたかどうかが一考慮要素になるのではないかと整理をしています。この辺りは、行政解釈と類推解釈禁止という司法警察処分観の観点か



らいうと、齟齬が生じやすいところかもしれないと感じました。

いずれにせよ、以上のような課題が生じ得るわけですが、寺西先生は、安衛法・施行規則等の類推解釈が生じている背景として、行政法規は多少内容が曖昧で幅広く解釈できる余地があるほうが、行政が円滑に遂行できて行政目的を達成することができるという非常にポジティブな側面もあるとします。そして、行政実務では、規定の文言を足掛かりとして類推に類推を重ね、あるいは極端な拡張解釈をして適用がなされる場合もあると指摘します。安衛法についても、労働基準監督官、指導を受ける事業者等の双方が安衛法に対する罪刑法定主義の適用に係る理解が不十分な側面があることもその背景として指摘しています。いずれも寺西先生の著書の内容ですので、私の見解ではないということはお断りしておきます。

そして、三柴先生からいただいた課題として、イギリスの安全衛生法典に関する問題です。これについては、私も2016年の報告書を通じて勉強しているところですが、一般的義務条項が定められ、それぞれに罰則規定が設けられています。内容としては、①使用者による安全衛生基本方針の策定であったり、方針の効果的な実施のための措置、などといった内容が定められています（HSWA第2条）。また、危険有害物質を取り扱う施設の管理者による最善の方法による環境危険有害物質の管理義務（同第5条）、③物の設計者、製造者、設置者、輸入者、供給者等への諸種の義務（同第6条）なども定められています。その上で、国会の承認を得た安全衛生規則が設けられます。そして、三柴先生の調査で何度も強調されていたのが、「行為準則」です。これは、安全衛生部局が制定できるガイドラインなのですが、行為準則について所管大臣の承認を受けた場合については、行為準則が一般的義務条項の解釈として承認を受けるという形になり、実際に刑事罰を科すに当たっては承認された行為準則が相当程度斟酌されます。そのような構造を持っていることが、2016年の報告書の中で示されています。その中でBalfour Beatty社事件、これはハットフィールド脱線事故に対する処罰例ですが、1億円近い罰金が科せられたケースもあります。この点日本法のように細かなルールを各法、各施行規則に定めるやり方とはかなり異質なものであり、イギリスでは一般的行為準則を定め、具体的には施行規則や行為準則を作り、場合によってはその中で罰則規定を設け、一般的義務条項と関連させながら、時に司法刑事的な機能を果たし、時には行政ガイドラインあるいは民間企業に対するガイドラインとして機能します。言わば法であって法でないという表現がありましたが、まさにそのように柔軟なルールであるというのがイギリス労働安全衛生法の大きな特徴であると思われまます。

わが国との比較ですが、わが国は言うまでもなく安衛法において罰則が定められています。これに基づいて委任を受け、各施行規則が定められています。そういう構造になっていますので、先ほどの罪刑法定主義の問題が生じてくることは否定のしようがありません。先ほど三柴先生から、なぜ日本では安衛法に関して罪刑法定主義をここまで厳しく求めるのかという問いかけがありましたが、一つの見方として、日本の場合は労働災害に対する刑事処罰については、安衛法による処罰と刑法第211条の業務上過失致死傷罪に基づく処罰が両建てになっている点があり、実際重大な労働災害事案においては警察と労基署が共同し（場合によっては仲違いしながら）刑事訴追を行っています。イギリスの一般的義務条項については、私の印象ですが業務上過失致死傷罪に類似していると感じました。安衛法は予防のために事前にルールを定め、禁止事項を設定し、違反があれば処罰し事故が生じたかどうかは問わない構造です。しかし業務上過失致死傷罪は言うまでもなく、実際に怪我をした人が出た場合に結果から遡って原因に対して予見可能性・結果回避可能性ゆえに刑事責任を問うことができるのか否かが争点となります。重大な労働災害事故が生じた場合には、労基署は安衛法違反で立件を試みますが、警察は結果から遡っ

て予見可能性や結果回避可能性があったのかを調べます。現場で警察の方に“安衛法にはどのような規定が書かれているのか”と尋ねられた記憶がありますが、安衛法の内容に関しては警察も関心が高いようです。あるいは、“労基署はどのような指導をしているのか”と問われることもありました。予見可能性・結果回避可能性に即して言うと、通常の企業人としてかかる事故を招かないためにどういうことをしなければならなかったのか、ということのを予め熟知していたかどうか業務上過失致死傷罪の立件に当たっては非常に重要な問題であったし、これからもそうだと思います。イギリスの行為準則は現行の安全衛生施策においても、これを豊富化することによって刑法と安衛法の懸け橋としての機能を果たするかもしれないという印象を持っています。さらには、警察が動いてくれない代わりに安衛法違反や労働災害に対する評価は労基署が引き受け、そうである以上安衛法に業務上過失致死傷罪に近い構成要件を明確に定め、労基署が立件するという方向をたどるのか、こういった点について今後の施策としてあり得るのかも知れないという印象を感じています。

以上、報告を終わらせていただきます。

三柴 ありがとうございます。ご質問等ございましたらお願いします。

南 これは三柴先生にお伺いすべき質問かもしれませんが、イギリスの刑事法の体系と日本の刑事法の体系をそもそも比較検討できるのか、今一つ分からないところがあります。というのも、イギリスの刑事法は罪刑法定主義の原則に服するとはいえ、裁判所におけるコモンロー上の義務を通じて明確化を図るという側面があるのに対し、日本は制定法主義をとっていますから、日英両国の刑事法の体系はどの辺りまで比較対象としていいのか、分かりかねるとというのが疑問の一つです。もう一つは、北岡先生のご報告の中で興味深いと思ったのは、前回の分担報告書で触れられている一般的義務条項が業務上過失致死傷罪の架け橋になるというお話です。私が主として取り組んでいる船舶関連の法においても似たような話があり、船舶で事故が発生した際に乗組員が死傷することがあり得るわけですが、そのような場合には直近過失といって、リスクアセスメントを実施したか否かについて検察はほぼとらないんです。事故が発生した直前に何をやっていたかを非常に気にするわけです。業務上過失致死傷罪は、アセスメントよりも結果を生じさせた直前の行為しか問題にしないと一般的に言われているので、労働安全衛生においても同様に考えていいのかどうか。労働安全衛生法違反や業務上過失致死傷罪における過失の評価の仕方が従前どうなっていたのかを明確にしないと、架け橋になるかどうか分かりませんので、その点よろしければご教示いただければと思います。

三柴 私から申し上げますと、今のご指摘は法体系そのものにかかわる重要なご指摘です。一般に法学においては、ヨーロッパを中心とした大陸法系とイギリスとアメリカが採用している英米法系に分かれると説明されています。大陸法系はパンデクテン方式といって、議会で成文の法を体系的につくって、それを解釈することを通じて個々の事件を解決・処断していくものです。日本では民法が一応その考え方になっています。民法は「編」「章」「節」による条文の整頓が出来上がっていて、時折改正されることもありますが、基本的にはしっかりした体系なので、いったん作り上げてしまえば簡単に変える必要はありません。そういう仕組みになっています。他方、英米法系は一言でいうと「積み上げ式」です。まず事件が発生し、それに対する判決が出て、その積み上げによって後付け的にルールが明確になってきます。



大ざっぱに説明すると両者にはそのような仕組みの違いがあります。

日本はどうかというと、概ねその中間であるといえます。憲法は基本的にはアメリカからの輸入で、労働基準法もアメリカで、刑法はドイツ、といったように各法分野ごとに異なる国から輸入した形になっています。なので、いずれの法系なのか今一つ判別できません。では、安衛法はどうすべきなのかということなのですが、やはり日本の安全衛生法についてはアメリカとイギリスです。イギリスは実態として労災防止の成績が良好だということもあって、何かにつけ行政はイギリスを参考にします。業務上過失致死傷罪との関係では、直近の状況のみ問題とする先ほどのお話は大変興味深いのですが、日本における運用では、労基法違反・安衛法違反との関係では、やるべきことがハッキリしていたかということと、それに違反したことが悪質だったかが問われます。両者を充たすのであれば業務上過失致死傷罪で立件するというものです。悪質か否かは発生した結果の重大性如何であり、たとえば相当数の死者が出たような場合には悪質であったとして訴追の対象となります。

北岡先生、いかがでしょうか。

北岡 難しい問題ですね。業務上過失致死傷罪の「過失」と安衛法上の行為との関係については、安西・寺西両先生がかなり詳細な検討をしていますので、その辺りは私もこれから勉強しようと思っています。

浅田 よろしいでしょうか。イギリスの労働安全衛生法（HSWA）を最初に読んだときに違和感を覚えたのは、先ほどのお話のように行為準則に反していれば法違反が推定される旨の条項があったと思います。通常、刑罰法規の要件を充足することについての立証責任はすべて検察側が負担します。しかし、法違反の推定はそれを逆転させるわけですね。被告人の側に立証責任を負わせるわけです。日本では非常に考えにくいことが、なぜイギリスでは可能なのか、この点が印象的であると同時に違和感を覚えたところですね。いったいなぜ、このようなことが可能なのでしょうか。

三柴 正鵠を射たご指摘で、私も悩んだところです。結局今のところは、イギリスが文化として安全衛生を重視しているとしか言いようがありません。ですから、ECが労働時間規制をイギリスに強制する際にも、これは安全衛生の問題ゆえだからと口説いた経緯があることからわかるように、イギリスが文化として安全衛生を重視していることは間違いありません。では、法の設計、解釈、運用において、ACOP（行為準則）がなぜそこまで法律に近い位置づけをされているのかといえば、結局はACOPを制定する行政機関にそれ相応の信頼と権限が与えられているということなのでしょう。ACOPは安全衛生問題に限ったものではないので、一般的にそういえるのかはさておき、少なくとも安全衛生法との関連ではそうだと思います。少なくとも現実の機能を見ればそう言いうると思います。さらに言えば、イギリスで労使と専門家にインタビューを重ねましたが、ACOPに反しているけれども、事業者が独自の手法をとっている結果、法の目的を達していたがためにACOPを外れていながら法違反の評価を免れた例の有無を尋ねたところ、誰も答えられませんでした。ACOPはガイドラインだということ言いながら、HSWAの中で法律に近いものだと明記し、さらに実際上も法律に近い運用をしているわけです。それはなぜかと言えば、安全衛生面を重視しているからという以外に今のところ把握できていません。

浅田 ありがとうございます。

三柴 それでは、次に大藪先生にご報告をお願いいたします。大藪先生にはいくつかのテーマをご担当いただいておりますが、今回ご報告いただくのは、安衛法上の免許制度に関する条規です。したがって、安全衛生に関する公的な免許制度はどういう趣旨のものであるか、などといったことを主にお話しいただくこととなります。

大藪 今回配布させていただいた資料（以下「大藪資料」とする）は全部で7頁になりますが、全体の構成としては、まず冒頭に「1. 第8章の概要」と題して記載した注釈、「2. 沿革」では条文についての沿革、そして本日の報告のメインになるのは大藪資料4頁「3. 免許 / 免許制度」の箇所です。ここでは主に3つの資格から、労働安全衛生法に限ったものではないのですが、免許・資格制度について説明しています。そのうち、「(1)「免許」について」は行政法学の立場から解説し、「(2) 政策の執行活動としての「免許」制度」、これは現在の私の専門分野ですが（大藪資料4頁中頃）、行政学（最近は公共政策と言いますが）からの視点、そして大藪資料5頁「(3) 公的規制と社会的規制について」、これは経済学において日本では90年代に公的規制論・社会的規制論が議論の対象となりましたが、経済学から見た社会的規制の中の免許・資格制度に関する議論がどのようなものかを示したものです。三柴先生からいただいたテーマはこれにとどまるものではないのですが、今回は時間的な余裕もなかったということで、公的資格制度における免許の性格についてお話ししたいと思います。

大藪資料1頁に戻っていただいて、まず「1. 第8章の概要」ですが、ご承知のように第12条第1項（衛生管理者）、第14条（作業主任者）、第61条第1項（就業制限）の免許及び技能講習の細目について規定しています。具体的に見ると、第72条から第75条において、免許の交付、免許証の有効期間の更新、免許の取消し、免許試験の実施について、それぞれ必要な事項について規定しています。また、第75条の2から第75条の12までは、免許試験の実施に関する事務の全部又は一部を行う指定試験機関について定めるということですが、現在は行政が直接実施するのではなく、試験事務は指定試験機関に委任しています。この辺りの根拠条文が示されています。そして、第76条では技能講習の実施について必要な事項を規定するとともに、第77条では技能講習等を行う登録教習機関・・・こちらも民間団体ですが、その監督に関する事項について定めています。この辺りはコンメンタールに書かれているとおりですが・・・

三柴 途中ですがよろしいでしょうか。ひとつコメントを差し挟ませていただきますと、日本の法制度においては、とにかく国家資格や国が委託する講習などが制度化されています。イギリスやアメリカでは、民間資格が中心です。その点だけはお伝えしておきたいと思います。すみません、ご報告の続きをお願いいたします。

大藪 ありがとうございます。その辺りの公的資格と民間資格の議論は経済学の議論とも関わってくると思います。次の「2. 沿革」ですが、大藪資料の方には条文しか示しておりません。しかも関連する条文のうち汽罐取締令などは割愛しております。戦前は「免許」という言葉を使っていませんでしたが、工場法や工場法施行規則などにおいて、就業制限や現行の免許制度の前身となる条文が規定されていました。大藪資料2頁の下の方には、「労働条件基準法（労働保護法）草案」（昭和21年7月26日）や「労

働基準法草案」(昭和21年12月24日 労務法制審議会答申)など、労働基準法ができる直前の草案における関連条文の案を記載しました。この辺りの検討が必要かどうかについては、また後ほどご教示いただければと思います。

大藪資料3頁には旧労基法、すなわち現行安衛法が施行される直前の関連条文を掲載しました。危険業務の就業制限(旧労基法第49条)ほか、同条にいう「経験のない労働者」、「必要な技能を有しない者」の意味については、ここに記載した旧安衛則ほか当時の政省令に定められ、免許に関する規定も定められています。同頁に記載した「労働安全衛生法(案)」は安衛法制定直前のものですが、このときには「第8章 就業制限」の中に、「第1節 免許」「第2節 技能講習」「第3節 指定教習機関」といったように、現行の条文とは異なる構成になっていました。分担報告書にはより詳細な経緯を書こうと思っているところですが、エポックメイキング的な出来事としては、昭和52年改正による「指定試験機関による免許試験の実施」が大きな制度改正ということになります。このプロジェクトは一般の人に分かり易い本を作ることが目的なので、免許の変遷に関して調査した限り、労基法施行当時は5種類の免許だったのが、その後徐々に枝分かれし、あるいは新設されることによって現在複雑な免許制度になっているという事情があるので、戦前からの沿革も含む免許制度の変遷の図式等を付すことも検討しています。

大藪資料4頁に移りますが、「3. 免許 / 免許制度」をそれぞれの専門分野からみた場合にどうなるかということです。非常に簡単にまとめたものですが、まず「(1)「免許」について」。講学上、免許とは「法令によって、一般には禁止されている行為を特定の場合、特定の人だけに許す行政処分」と解されています。また免許制度とは、「営業に当たって行政官庁の審査を受けなくてはならないこと」を意味し、所定の資格を有していれば営業を許可される登録制と異なり、免許制の場合は拒否されることもあるということです。次いで、スタンダードな行政法学の基本書に書かれていることですが、法令における免許は「一般には許されない特定の行為を特定の者が行えるようにする行政処分」とされているところ、規制行政の中でも主要な法的仕組みとしての許可制における用語として用いられています。行政実務上では様々な言葉が使われていまして、許可、承認、免許、登録、確認、認定、認証など、用語法が一定していません。ただ、立法実務では、需給調整を行うものには「免許」の語を用い、需給調整条項が廃止された場合には「許可」に変更した事例があるということで、多少交通整理が行われつつあるというのが現状です。

次に「(2) 政策の執行活動としての「免許」制度」に移ります。こちらは行政学、最近では公共政策といいますが、私の専門分野からみた政策の執行活動としての免許制度の話です。この辺りも図式を加えればよかったのですが、行政学(公共政策)の視点で見ると、課題の設定、政策の企画立案、政策の決定(国レベルでは国会での法律の制定)、そして実施です。労働安全衛生法に即して言えば、労働基準局が施行通達を出し、各労働局や労基署に伝わっていくというのが実施に相当する過程です。そして、その次に政策の評価があり、その結果によりまた最初の課題の設定等に戻るという理解をしています。もちろんこれは教科書的なモデルなので、必ずしも現実はこの通りに進むとは限らないのですが、一応すべての政策分野に共通の物差しとして、政策過程論ないし政策段階論と称します。こうした5つほどの段階で構成されています。その中で、1970年代以降折注目されるようになったのが、政策の執行活動であり、企画立案した政策が適切に実行されるのか、その一番重要な執行活動において免許制度が非常に重要であるということが研究されるようになっていきます。日本では特に1980年代以降、数は多くありませんが徐々に進んできています。免許制度とはどういうものかということ、大藪資料4頁に示したよ

うに、有効な社会管理を行うための行政手段であって、多数の人々に対して比較的緻密で効率的なコントロールが可能なので、多くの政策分野で採用されています。最も身近なところでは自動車運転免許、あるいは教員免許や医師免許などがそうです。もう少し厳密な定義をしますと、アメリカの学者による定義ですが、「それなしには禁止されているところの、ある特定の事業を営んだり、専門職 (profession) に就くための、または一定の行為を行うための公的承認 (an official permit)」であり、「人々の行為を一律に禁止し、一定の要件を充足する者だけにその禁止を解除することによって人々の行動をコントロールする」行政手段とみなされる、ということです。

そして、有効な社会管理を行う行政手段としての免許の特質としては、大藪資料4頁に示した三点が挙げられます。まず「①人々の行動経路上に隘路を設定し、隘路において人々の行動の適切性をチェックし、適切な者だけに隘路の通過を認めるものであり、一定の行動をしようとする人々が隘路を通らなければその行動を行えない点において、多数の人々を網羅的に例外なく、しかも効率的にコントロールすることができる行政手段であること。」です。たとえば、好き勝手に医師を名乗って医療行為を行うことができないといったように、一定の能力を持っていない人を危険な業務から遠ざけることが可能になるということです。次に、「②人々が行動を行う前にその行動の適否を判断する点で、社会において発生する可能性のある様々な危険や弊害を未然に防止する機能を持っており、煩瑣で時間のかかる事後的な是正や救済よりも優れた行政手段であること。」つまり、事前にチェックすることで、あとに生じ得る被害をある程度コントロールできるというのが免許制度の大きな特質の一つと言えます。最後に、「③一定の行為をしようとする者の申請に基づいて与えられるが、この申請を前提にしている点、すなわち免許という行為のイニシアティブがまずは免許を求める側に要求され、行政機関は受動的に申請があつて初めて作業を開始すればよいという点で非常に効率的なコントロールの手段であること。」

以上のほか、免許の特質に関する細かな議論としては、代表的なものを二つ紹介させていただきます。すなわち、コントロールの効果を高める方法として、「①免許の付与・拒否という二者択一的なコントロールではなく、免許に個別具体的な条件を付すことでより緻密なコントロールを行う」、「②事後的なコントロールの仕組みとして、免許の効力に期限を設け、免許の継続に関する適否をチェックして更新するシステムを導入するなどの工夫もなされる」。

政策過程からみた免許制度は重要なものがありますが、日本の行政システムの特徴からみると、「最大動員」という概念の一つの現れとされています。国の行政機関は、人、物、金（予算）が限られているので、行政機関以外のリソースの活用が含まれるということで、この点日本に限ったことではないのですが、日本的な特徴としては、各種免許制度の運用においても民間部門（各種団体、企業）の活用（指定試験機関、登録教習機関など）が図られている点が挙げられます。

次に「(3) 公的規制と社会的規制について」(大藪資料5頁)。この辺りは今回の分担報告書に必要なかどうか分からないのですが紹介させていただきます。まず経済学の分野においては、日本の場合1990年代から社会的規制のあり方について見直しをしようという動きがあり、特に当時の通産省が行政機関による公的規制・・・三柴先生が仰った民間規制と対比されるものですが・・・に関しては「経済的規制」と「社会的規制」に分けられるとしました。この辺りのことは、大藪資料5頁(3)の2段落目「公的規制は、規制の目的に応じて経済的規制と社会的規制に分類されることがある。」以下に記載しましたので、関心のある方はご覧いただければと思います。簡単に言うと、企業の参入・退出、価格、サービスの量と質などの行動をコントロールしようとする場合が経済的規制に当たります。たとえば、電力料金の上げ



下げ、あるいは医薬品販売の業界に参入する場合の要件などといった問題が経済的規制に関わるとされています。もう一つは経済的規制に該当しないところで、社会的規制も存在するという議論があります。社会的規制の中核的な分野としては、①健康・衛生の確保（公衆衛生・医療、環境衛生の確保、麻薬等の規制）、②安全の確保（自然災害の防止、産業災害・労働災害の防止、交通事故・火災事故の防止、製品・サービスの事故の防止）、③公害防止・環境保全（公害防止、廃棄物処理、環境保全）の分野といった辺りが挙げられます。先ほど例に挙げた医薬品販売も社会的規制にかかる部分がありますが、こういった規制をどのようにすべきかという議論が、1990年代後半の規制改革の一つのトピックで、先ほどの先生方のご報告の一部にもありましたように、規制改革ないし規制緩和の流れの中で労働安全衛生法の規制もいくつか影響を受けています。

次に、大藪資料5頁下の方に移りますが、社会的規制の具体的な手段（直接規制）には許可制・認可制などの法的仕組みのもと、経済学上の分類になりますが、①特定行為の禁止・営業活動の制限、②資格制度、③検査検定制、④基準・認証制度、⑤その他の方法といったように、様々な規制手段が存在するとされています。労働安全衛生法の免許・資格制度はこのカテゴリーのうち2つに関わってきます。すなわち、「①特定行為の禁止・営業活動の制限」と「②資格制度」です。特に①ですが、大藪資料5頁から6頁にかけて記載したとおり、①特定行為の禁止・営業活動の制限に関しては、国の関与の程度によって以下の3つのグループに分類できるとされています。免許制度などは、Aグループの強い規制の中に含まれます。

- ①Aグループ（強い規制）：一般的な禁止を特定の場合に解除する行為、特定の権利を設定する行為など（例：許可、認可、免許、指定、承認など）。
- ②Bグループ（中間の規制）：特定の事実や行為が、あらかじめ定められた基準を満たしているか否かを審査・判定し、これを公に証明する行為など（例：認定、確認、証明、認証、試験、検査、検定、登録、審査など）。
- ③Cグループ（弱い規制）：一定の事実を行政庁に知らせるもので、行政庁は原則として記載事項を確認するにとどまるもの（例：届出、提出、報告、交付、申告など）。

次に②資格制度ですが、定義としては「製品等の物的なものに結びついた技術ではなく、消費者や企業に対して一定の役務を提供する者自体の有する技能水準を、公的に確認・保証するための仕組み」となります。この辺りはクレーンやボイラーなど安衛法が指定する業務独占資格等の類型が関わってきます。次の③検査検定制および④基準・認証制度については、安衛法に関わってきますが、今回私が担当している第7章には関連が薄いので、割愛させていただきます。

「(3) 公的規制と社会的規制について」に関しては、私が記憶している範囲では90年代の後半から21世紀の前半にかけて、社会的規制の改革のところで議論の対象となりましたところ、規制改革の建議会では業務属性資格については見直しをすることとされていましたが、当時の総務庁から旧労働省に対して見直しをするべきとの要請が入ったのは、検査検定制等についてであり、免許制度については現在も旧労基法から現行安衛法に受け継がれて安全衛生のために重要な役割を果たしていると理解しています。行政学の観点からすると2つのルートがあり、官僚制がどういう行動をとっているかという点と、もう一つはもともと行政学はアメリカの影響を受けており、経営学の観点からどのように社会管理をしてゆくかという論点があります。労働安全衛生法から免許制度をみた場合、官僚制の行動と安全衛生の確保という目的に即してどう上手くコントロールするのかという経営学の視点も関わってくると、あら



ためて感じた次第です。三柴先生からの宿題としての免許制度の意義については、あらためて実際の局面について調査すべきかと思っておりますので、そちらの問題も現在検討中でございます。

以上、報告を終わります。

三柴 ありがとうございます。時間の都合上、次に進めたいと思います。平岡先生、ご報告お願いいたします。

平岡 配布資料（以下「平岡資料」とする）の表題にあるとおり、「建設業における土砂崩壊に関する労働法」というテーマで安衛研にてまとめさせていただきました。私の専門分野が土砂崩壊ということもあり、建設業における土砂崩壊に関する条文の制定経緯を簡潔にまとめることを目的としています。今回は昭和47年制定の安衛則に至るまでの経緯をまとめました。日本は炭鉱産業が盛んだったという事情もあり、鉱業において土砂崩壊に関する規定が最初に生まれています。それが土石採取業や建設業へ広がっていきました。土砂崩壊を原因とする労働災害は、そもそも土をいじっている、つまり掘削をかけている際に生じます。どのような産業で起きるかといえば、鉱業において鉱山の掘削を行う、土石採取業で採取をしている、あるいは建設業で地山を盛るあるいは掘る際に生じます。また、林業や農業でも生じることがあります。

歴史をたどっていくと、平岡資料25頁「表1 工場法が制定されるまでの鉱業に関する法令の変遷」に記載したとおり、鉱業を対象とした法令が早いうちに制定され、工場法が明治44年に制定されていますが、鉱業に関してはそれより以前に各種法令が制定されています。まずは明治2年に、国家の請負を前提として、鉱山の開拓が一般人民に開放されるという経緯があり（行政官布告第177号）、その3年後の明治5年に「鉱山心得」が出され、これによって鉱物が定義され、鉱業の国家独占主義と外国人の排斥の原則が確立されました。その1年後の明治6年に施行された「日本坑法」は、最初の体系的な鉱業法ですが、同法の中で安全衛生に関する規定といえば、一部に災害予防規定の片鱗が見受けられるにすぎない状況でした。それからだいぶ月日が経った明治23年に鉱業条例が施行され、これによって鉱山労働者（鉱夫）の安全が初めて法令に組み込まれました。鉱業条例は国立公文書館に原文が保存されていて（平岡資料26～27頁参照）、ご覧のようにその「第5章 鉱業警察」の第58条に「鉱夫ノ生命及衛生上ノ保護」という規定があります。それ以降明治25年に鉱業警察規則などが制定され、明治38年には現在の鉱業法の前身である「鑛業法」が制定され、これが鉱業法や鉱山保安法につながっていくわけですが、この法律の「第四章 鉱業警察」第71条から第74条にかけて鉱業における保安について記載されています。

その後昭和6年に労働者災害扶助法が制定され、関連規則として昭和9年に土石採取場安全及衛生規則が、昭和12年には土木建築工事場安全及衛生規則がそれぞれ制定され、その中で土砂崩壊についての規定が初めて設けられているのが確認できました。土石採取場安全及衛生規則では、第7条に土砂崩壊関連規定が定められています。土砂崩壊の話からは脱線しますが、同規則の第15条に40度以上の斜面では墜落防止措置を講じなければならない旨の規定がありますが、これは現行安衛則の第518条、第539条および解釈例規に相当する内容です。昭和9年の段階でこう配40度という数値が定められ、現在に引き継がれている様子が見えます。土木建築工事場安全及衛生規則第3条にも土砂崩壊に関する規定が定められています。ここで少々意外に思ったのは、この時代の規定にすでに監視人を配置

する義務を定めた規定があり、思ったよりも早い時期にこのような規定が設けられていたというのが印象的でした。土木建築工事場安全及衛生規則制定の1年前に、これに関する「土木建築工事場ノ安全及衛生ニ関スル注意書」が出されていますが、安衛研の蔵書の中にありました。この中に、昭和7年から9年の建設業の災害統計が掲載されていまして、また案文が書かれていました。これがほぼそのままの形で同規則になっています。つまり、統計をとってこれに基づいて案文を策定し、それをほとんどそのまま規則として制定しているわけです。昭和7年は一番最初に統計をとった年なので、最初の統計データとなります。

昭和18年に「土木基本作業法」という報告書がだされたのですが、これも安衛研の蔵書の中にありました。題名に使われている“法”は法令という意味ではなく、方法という意味で使われています。すなわち、土木作業の方法を非常に詳細に記載した本であり、シャベルの使い方ひとつとっても非常に細かく書かれている本です。同書の執筆公刊にあたっては、厚生省、警視庁、そしてゼネコン各社が参与した委員会が設置・開催され、現場での作業方法などもゼネコンの意見も踏まえながら書かれた本ようです。同書に具体的な数値を書いた箇所があります。たとえば「此の場合一段の高さが〇米五〇乃至二米〇〇位になる様に階段状に區畫して格段層を掘進み」といった感じです。法令による規定ではないものの、こうした具体的な数値を定めた最初の例ではないかと思えます。

その後昭和22年にご承知のように労働基準法が制定され、旧安衛則も定められることとなりますが、旧安衛則第116条から第120条までが土砂崩壊関連の規定になっています。これは、それ以前の土建規則や鉱業警察規則等の内容を集約したもので、旧安衛則の条文はいずれも戦前の各規則のいずれかに相当する内容になっています。もっとも、現行安衛則の第356条・第357条に掘削のこう配や高さに関する規定があり、具体的な数値が定められています。しかし、旧安衛則の時点ではそのような具体的な数値は盛り込まれていませんでした。旧安衛則の制定により、従前鉱山の安全衛生を規制していた鉱業警察規則と重複が生じるわけですが、両者の調整が試みられ、商工省の鉱山課から労働省労働次官宛の文書が現在もネット上で閲覧可能です。現在では、労働災害発生時には厚労省の管轄になりますが、鉱山の掘削のこう配等々の規制はおそらく経産省が担っていると思えます。その辺りの調整の形跡は、この文書によって明らかになります。調整が首尾よく進んだかは不明ですが、この辺りについては濱口桂一郎著「日本の労働法政策」に詳細が書かれているところ（平岡資料12頁右段）、どうやら調整は不首尾に終わったようです。時間の都合上詳細は割愛しますが、後ほどご覧いただければと思います。

その後、旧安衛則の改正がなされていきますが、それに先立って検討がなされた結果、労働災害が多発していたために注意喚起の意味で、様々な小冊子が出されました。たとえば「土の切取工事の安全」という小冊子が昭和27年に発行されています。ここでは、昭和25年および昭和26年の上半期に発生した土木工事における労働災害事例が詳しく分析されています。これらの分析を受けて、旧安衛則の改正につながっていくという印象を受けます。脱線になりますが、昭和30年に「土砂崩れ」というハンドブックが広島労働局から発行されましたが、これが非常に詳しい内容になっています。地盤工学の専門家が大学で習う土質力学などが非常に詳細に書かれています。驚くべきは、1955年に発行されているのですが、土質力学の父と言われるカール・テルツァーギが1948年に発表された金字塔的な論文、そして日本の土質力学の父といわれる最上武雄著「土質力学」などが引用されている点です。すなわち、行政側は、当時の最先端の土質力学の知見を基にした労働災害防止対策を検討していたという姿勢がうかがえます。

旧安衛則の大きな改正は昭和40年になされていますが、そのほとんどが昭和47年制定の現行安衛則の原型になっていると思われます。改正の中心となったのは、前郁夫という安衛研の第10代所長ですが、同氏が厚労省におられたときに詳細な分析を行い、法改正に結び付けました。私の前任の伊藤先生が前氏に、なぜこのような条文になったのか等についてヒアリングを実施し、その結果をまとめた論文を出しています。そこに詳しく書いているのですが、昭和40年の改正には大きな根拠が2つあります。一つは昭和34年通達（昭和34年5月15日基発第367号）で、高さ2m以上の法面下作業について、緻密な岩盤及び堅硬な粘土を除いて75度を超えない勾配の基準とするように指導を行っていたこと、そしてもう一つには昭和29年から昭和33年に発生した重大災害64件を分析し、いずれの事件も地山の種類やこう配、高さなどが判明しているため、それらのデータをもとに線引きしています。これが後に現行安衛則の第356条・第357条につながっていきます。昭和34年は規則の改正が数多くなされていますが、それは昭和33年に第1次労働災害防止計画が策定され、それを受けて改正されたという経緯があります。土砂崩壊に関しては、その時期の改正から漏れてしまったようです。他の問題よりも検討にある程度の期間を要するからではないかと思いますが、昭和34年改正に間に合わずに昭和40年に改正がなされたのではないかと思います。そして、昭和40年改正の内容がほぼそのままの形で、昭和47年安衛法の政省令である現行安衛則に移行し、現在の内容になっていることが分かります。

平岡資料に書かれた内容の大枠は以上のとおりです。現在ガイドラインが色々出ていまして、法改正の代わりにガイドラインで対処しています。たとえば、土止め、斜面、山岳トンネル、土石流などについてガイドラインが出ており、大きな災害を契機にガイドライン化されたなどといったものがみられますが、その辺りについては来年度以降追加的にまとめようかと思っています。

以上、報告を終わります。

三柴 ありがとうございます。時間も時間ですので、質疑は省略させていただきまして、次回の会合は12月24日を予定しています。それまでに、分担報告書のご担当者は提出していただく必要があります。また、当日ご報告いただく方については、事前にご相談の上、分担報告書の概要についてのご報告をいただきたいと思います。本日も長時間に及びましたが、安全衛生の幅と奥の深さを感じさせ、様々な分野からの知見が化学反応を起こすようで、知的にも人的にも非常に興味深い数々のご報告をいただいたと感じています。

本日もご報告いただいた先生方、ありがとうございます。またご参画・ご議論いただいた先生方にもあらためて御礼を申し上げます。今年度もいい報告書をあげたいと思いますので、ぜひご助力をお願いいたします。

それでは、長時間にわたってありがとうございました。

三柴 本日もご参集いただきありがとうございます。本日はまず篠原先生から「安全衛生法と現場、安全衛生教育の効果」と題して、監督官時代のご経験をふまえながら現場のお話をいただこうかと思っています。また、15時に愛知産保センター副所長の久保監督官から化学物質管理の監督指導についてお話しいただく予定です。資料を拝見したかぎり、監督指導の現場で化学物質管理がおざなりにされている様子が窺われます。次いで、法学者グループから分担報告書の執筆経過についてお話しいただく予定です。一部予定していた方で、本日出席できない方は、次回お願いするというので、本日まで参加いただいている方からご報告いただく予定です。報告者の方でまだ資料をお送りいただけていない方は、今からでけっこうなので、MLで配信・共有をお願いいたします。

では、まず篠原先生からご報告をお願いいたします。

篠原 本日は「安全衛生法と現場、安全衛生教育の効果」ということで、20分ほどお話させていただきます。私は10年にわたり監督官として様々な現場に足を運びましたが、監督官を退職してからかれこれ18年ほど経ちました。現在はコンサルタントとして現場を回り、監督署の方にお尋ねし、あるいは逆に講師の依頼を受けたりもしますので、現時点を中心に現場のお話をしたいと思います。MLで配布した資料（以下「篠原資料」とする）に沿って説明いたします。

最初に「I. 安全衛生法と現場」・「1. 法令遵守！！～安全衛生活動が活発な会社はどのような会社か」（篠原資料1頁）ということですが、まず言うまでもなく「①上場企業及び関連会社」です。こうした企業から、例えば、就業規則の中に15歳未満の児童労働をさせない旨の規定を設けたいが、どのような表現がいいかといった質問を受けます。要は、日本はアジアの一国に過ぎず児童労働を未だにさせているのではないかというイメージがあり、それを払しょくするために児童労働禁止規定を設けなければならないということです。安全衛生も含め労働条件に関する法令遵守は、事業を継続するうえでも必須であり、上場企業にとっても重要な課題です。法令遵守について最も意識が高いのは、「②労働災害を契機として安全衛生の重要性を深く認識した会社」です。次に、「③事業継続のため労働安全衛生活動が必須である会社（監査あり）」です。たとえば30人規模の小さな会社であっても、取引先が大きな会社であれば、取引先の方から何らかのマネジメントを要請されます。そして定期的に大手の企業から監査もあります。そういう企業では事業の存続がかかっていますので、経営者が強い意志で安全衛生に取り組んでいます。もうひとつは、「④苦労の末、強い競争力を持つに至った会社」です。一例を挙げますと、かつては取引先から無理難題を押し付けられ、社員がやる気をなくして死んだ魚の目をしているような状況であった街の企業が、粘り強く大学と連携して研鑽を重ねた結果、オンリーワン商品を作れるようになり、取引先も一新されて非常に頼りにされ、社員の目が輝き出すと、経営陣も安全衛生に積極的に取り組むようになった例があります。そういう会社も当初からそうだったというわけではなく、むしろなかなか法令を遵守することができない、いわゆるブラック企業だったわけです。そういうレベルから徐々に改善がなされ、社員が仕事に誇りを持ち、それに応えるように経営陣も安全衛生にも取り組み始め、今では表彰を受けテレビの取材なども受けるような状況になっているようです。最後に、「⑤「安全・衛生・安全衛生」旗、安全衛生方針を掲げている会社」は非常に安全衛生に前向きです。特に安全衛生方針です。安全衛生方針は、大きな会社であれば必ずあるはずなのですが、掲示されていません。逆にこれが掲示されている会社は安全衛生活動が活発で、上記②の大きな災害事故をきっかけに安全衛生の重要性を認識した会社などは、安全衛生方針を掲示しています。大口の取引先などで安全衛生管理の徹底を取引の必



須条件としている会社は、HP上で安全衛生方針を示しています。

私が現場で心がけているのは、労働災害はどうしても起こり得ます。しかし、死亡災害や後遺障害が残るような重篤な災害だけは絶対に防ぎましょうということを普段から強調します。製造業では、「はさまれ」「巻き込まれ」あるいは「墜落」「転落」によって命を落とします。また、フォークリフトなどが走っている中では「激突」事故もあり、フォークリフトは年間30人余りを轢き殺しています。これについても普段から災害事例も交え、厳しくお伝えしています。

労働災害の対策は、「モノ」と「ヒト」の両面で考えなければなりません。「作業手順」と「保護具」は非常に有効です。ただし、全員が100%遵守するのであれば有効なのですが、そうではないからこそ事故が起こりますので、「モノ」と「ヒト」の両面でみてくださいと伝えています。災害の原因分析をすると、「不安全なモノの状態」で82.9%、これに「不安全な行動」が加わると92.6%になり（詳細は篠原資料1頁参照）ますが、対策は主にモノの方からみていかなければなりません。篠原資料2頁に移りまして、「はさまれ・巻き込まれ災害は「モノ」で防ぐ」。労働安全衛生広報（2020年6月15日）にこんな記事がありました。「令和2年4月18日、福岡県の金属加工会社で、ドリルを使って金属を加工する作業をしていた男性作業員（26歳）の頭部委に、折れたドリルの刃（長さ120cm、直径5cm）が当たり、病院に搬送されたが死亡した。作業員は保護帽を着用していなかった。」確かに保護具は全員が100%着用してくれれば有効です。そうでないからこのような死亡事故が発生するというので、「モノ」で防いでいかなければなりません。いろいろな専門知識を持った担当者の方とお話していると、やはり抛り所となるのは法律です。労働安全衛生法は非常に上手につくられていますので、同法を抛り所にして、専門知識を持った人の知恵を借りることができれば、極めて有効な安全衛生管理を行うことができます。条文について掘り下げますと、たとえば、安衛則の第105条には、「事業者は、加工物等が切断し、又は欠損して飛来することにより労働者に危険を及ぼすおそれのあるときは、当該加工物等を飛散させる機械に覆い又は囲いを設けなければならない。」（第1項）と規定されています。では、この加工物の中にドリルが含まれるのかどうか。この点について通達が出ていまして、「第1項の「加工物等」の「等」には、切削工具が含まれること。」ということになっています。ここにいう「切削工具」とは何かということですが、篠原資料2頁に掲載したJIS規格が現場で用いられます。そこでは「切削工具」については、JIS B 0170に示されており、旋盤に用いる「バイト」、ボール盤などに用いる「ドリル」等が定義されていますので、切削工具の中にはドリルが含まれることになります。このように、法令に定義がない場合には、JIS規格を活用しながら対処してゆくことになります。篠原資料2頁【参考】JIS番号にあるように、JISにはアルファベットと番号が付されていますが、たとえば「JIS B 0170」というのは、「B 一般機械」のジャンルであることを示しています。そして「JIS Q 4500 1 労働安全衛生マネジメントシステム」が管理システムといったように分けがなされています。

篠原資料3頁に移りまして、「5. 重篤な労働災害は非定常作業で起こっている」。「非定常作業」とは、保守点検作業やトラブル対応など、日常的に繰り返される事が少ない作業のことです。通常、機械が普段通り正常に作動している状態では労働災害はあまり発生しません。しかし特にこれからの時期、たとえば家庭内で普段は使わない脚立を使うことがあります。これによって家庭での脚立による災害が増えます。あるいは、企業内で機械をいったん停止させ、また年始に再稼働させるといったときに最も注意を要します。篠原資料3頁の【事例1】ですが、都内大手のパン工場で22歳の女性従業員が、焼き上がったパンを冷やすための装置の清掃作業をしている最中、装置に挟まれ重体となった事案です。このよう

に、何らかの要因で機械や装置が作動してしまった結果の災害事故は非常に多いです。通常、中に人がいれば確かに作動しなくなるはずですが、中に人が入っている状態で作動する機械・装置もあります。次の【事例2】は大手家電工場の事案です。ベテランの男性社員が、冷蔵庫の部品を製造する機械に上半身を挟まれた状態で見つかり、死亡が確認されたのですが、この方は機械の故障のため、1人で点検作業をしていたということです。おそらく何らかの原因で機械が作動したものと思われます。現場で注意を要するのはこのような状況です。つまり、ベテランの従業員が単独で作業する場合、他の従業員が注意・指示することがなかなかできません。結果、一人で作業している際に事故に遭って発見が遅れるということになります。法令はどうなっているかという点、安衛則第107条に掃除等の場合の運転停止等に関する規定があります。すなわち、「事業者は、機械（刃部を除く。）の掃除、給油、検査、修理又は調整の作業を行う場合において、労働者に危険を及ぼすおそれのあるときは、機械の運転を停止しなければならない」（第1項）とされています。挟まれる危険のある箇所にわざわざ体をもぐりこませる場合には、安全装置を落として入っていきますので、非常に危険です。そういう場合には、機械の運転を停止せよというルールになっています。そして第2項によると、機械の運転を停止した場合には、第三者が作動させないように、「当該機械の起動装置に錠を掛け、当該機械の起動装置に表示板を取り付ける等同項の作業に従事する労働者以外の者が当該機械を運転することを防止するための措置を講じなければならない」とされています。かつてとある現場から「非常停止装置により機械の運転を停止し、機械の掃除等実施してよいか？」という質問が来しました。電源をいったん落とすと再起動に時間がかかるので、非常停止でもよいかという質問です。ここでJISをみると、「起動」については、JIS B 9714 3.1に示されており、「起動（start-up）、機械の起動（machine start-up）」について、「機械又はその一部の、休止状態から動いている状態への変化」と定義されています。そして「停止」については、行政通達として「機械の包括的な安全基準に関する指針」（平成19年7月31日 基安安発第0731004号）が出されています。この中で「停止」について、駆動源が電力である場合、「停止」には次の3つの方式（停止のカテゴリ）があることがJIS B 9960—1の9.2.2に示されていて、「カテゴリ0」が「電源を直接遮断することによる停止」、「カテゴリ1」は「機械が停止するために電力を供給し、その後停止した時に電源を遮断する制御停止」、そして「カテゴリ2」が「機械に電力を供給したままにする制御停止」になります。電気に詳しい人に言わせると、この状態で機械の掃除をするのは非常に怖い、いつ動き出してもおかしくはないとのこと。厚労省の解説でも、カテゴリ2の停止は、「電力を供給したままであることから、機械の運動部分が静止していても、運転を停止しているとはいえないことに留意する必要がある」とされています。これを読むと、電力が供給されたままの非常停止装置では不十分であることがうかがわれます。安衛法には技術上の指針等の公表等に関する規定があり（第28条）、これに基づいて「工作機械の構造の安全基準に関する技術上の指針」が出されていますが、先ほどの非常停止装置の是非について書かれていません。そこでJISを確認することになるわけですが、非常停止に関するJIS規格は篠原資料5頁掲載のとおりです。「(1) 非常停止機能」については、停止カテゴリ0または、1とするとされ、カテゴリ0は「モーターやシリンダ等の電源を直接遮断する停止状態」、カテゴリ1は「モーターやシリンダ等が停止する為の動力を供給し、モーター等停止後に動力を遮断する停止状態」です。カテゴリ0か1であれば問題はないのですが、カテゴリ2では「モーターやシリンダ等に動力が供給されたまま、制御によって停止している状態」なので、危険な状態です。ちなみに、「非常停止の解除により、機械が再起動してはならない」ということがJIS規格に定められています。非常停止装置

によって機械の運転停止として扱ってよろしいかという現場からの質問があれば、JIS規格により電源が遮断されるのであれば可ということになります。「(2) 非常停止機器の配置」についても、JIS規格で定められています。機械づくりの専門家の人たちの中にも、非常停止装置のJIS規格は初めて見たという人もいました。

次に、製造業では墜落・転落による事故もよく発生します（篠原資料6頁「6. 建物作業床の端、機械設備及び仕掛品からの墜落・転落を防ぐ」）。まずは、「(1) 開口部は塞ぎ、必要な時に開閉する」ことが求められます。建設業で、階段の開口部で人が転落して死亡する事故がしばしば発生します。某住宅メーカーから安全に関する助言を求められたので、現場に行ったところ、以前は開口部を塞いでいなかったのが重篤な墜落災害が繰り返されおり、開口部が金属製の扉で塞がれていました。そして、人が昇降するときだけこれを開けて、人が通り終わるとバネの力で閉まる仕組みになっていました。この扉で開口部が塞がれた現場では墜落災害はゼロになっており、やはり、設備上開口部を塞ぐモノの対策を採用すると、効果的に災害を防ぐことができます。また、柵としての手すりを設置することです（「(2) 効果的な高さの「墜落防止用の柵」を設置」）。掲載した図は、以前中災防が公刊した本からの抜粋ですが、手すりの高さは人間の体の重心よりも高く設定すべきということです。日本人の20代男性の平均身長が171cmですから、重心の高さはだいたい95cmになります。なので、手すりは95cm以上、できれば110cmを目指すべきだということがいえます。

「7. フォークリフトに「激突され」る災害を防ぐ」（篠原資料7頁）に移ります。最近監督署からしばしば指導されるのが、作業計画です。法令上、作業計画を定めたいうえで、作業計画に従って作業を行わなければならない、また作業計画を定めたときは関係労働者に周知しなければなりません。監督署からは正勧告を受け、作業計画を作って労働者に周知するわけですが、しばらくすると周知することが忘れられてしまい、労働者の配置転換に合わせて実施されていないケースが多いということです。また、制限速度（安衛則第151条の5）については、フォークリフトは「適正な」制限速度を定めよとの規制しかありません。そして働く人たちは制限速度を超えて運転してはならないとされています。しかし、現場は忙しくて労働者もせわしく動きますので、制限速度を守るのは難しいこともあります。なので、人とフォークが同一通路を走行する箇所があることから、メーカーに依頼して最大速度を3Km/hとした例があります。また、技術革新それ自体はいいことなのですが、無人フォークリフトの登場によってかえって災害が発生してしまう例もあります。たとえば、システムが壊れてしまうと手動運転せざるを得なくなり、手動運転が必要になった際に災害が起こり得ます。システムが不具合を起こすと運転できる人がいなくなり、やむなく運転をしたりすると誤運転で建物を破壊したり、機械に衝突したり、あるいは人に当たったりなどすれば大変なことになると思います。また(3)にあるように、運転席のない「ウォークリーフォークリフト」は、フォークリフトと認識されていないケースが多いです（篠原資料8頁）。その結果たとえば、受け入れたばかりの派遣労働者にいきなり操作を任せる、あるいはアルバイトの人に平然と使わせるなどといったことがあります。しかしウォークリーフォークリフトは、JIS規格によれば、篠原資料8頁に示したように、JISDにおいて「運転者が歩きながら操縦するカウンタバランスフォークリフト。簡易的な乗車装置を備えている場合もある。」と定義されています。ウォークリーフォークリフトが使われているのはだいたい最大荷重1t未満ですから、国家資格や技能講習まで求められませんが、少なくとも特別教育を行わなければなりません。特別教育は社内教育なわけですが、以前玉泉先生が仰っていた通り、ミニ就業制限です。これを実施していないと大きな災害につながります。非常に大切な教育なわけです。



が、ある会社でそれならやりますよということになった場合、ウォークリーフォークリフトに限定した特別教育はありません。小型（最大荷重1トン未満）の通常のリフト用の教育しかなく、それを受講してもあまり意味はありません。ところが、全工場の労働者対象に実施するような場合、特別教育が必要となる「フォークリフト」に該当するのかわかりませんという声も聞こえてきます。過去に、監督署に問い合わせたところ、丁寧に確認して下さり、自走してなおかつ動力で荷を上げて持ち運ぶものであればフォークリフトに該当するとのことでした。さらに、東京労働局から建設荷役車両安全技術協会宛に「ウォークリーフォークリフト」に係る労働安全衛生関係法令の適用等について」（平成25年9月27日）と題した事務連絡があり、その中に適用の詳細が記されているとのことでした。

ウォークリーフォークリフトは「フォークリフトである」という認識なく使用されているケースが多く、定期自主検査の対象とされていないことが多いです。篠原資料8頁「(ウ) 定期自主検査 (◎は特定自主検査)」に定期自主検査の表を記載しましたが、特定自主検査はプレス機械や建機などは法定の有資格者でなければ検査できない場合と、それ以外の人でもできる場合とに分けられます。フォークリフトの場合は最大荷重に関係なく月に1回は定期自主検査を、年に1回は特定自主検査を実施しなければなりません。フォークリフトとは別の機械設備ですが、あるメーカーに自主検査を依頼していたケースで、私が確認したところ、法定の検査項目が足りていませんでした。そこでメーカーの担当の方に、法定項目が足りていない旨お話ししたところ、自主的な検査ゆえ我々が必要だと思った項目について検査をしている、「自主検査」なんだから問題ないでしょうとの回答でした。こうした誤認を生じさせないよう、自主検査というより、「定期社内検査」と称した方が正確だと思います。ちなみに、特定自主検査も社内に資格者がいれば社内検査として実施できますが、メーカーにお願いしているケースが多いです。ともあれ、最近「自主」検査という点が少々引っかかっています。そして、「(エ) 使用している現場」においては、先ほども申しました通りフォークリフトであるという認識がなく、特定自主検査も実施していません。現場できいた話ですが、販売する側であるメーカーも最大荷重1トン未満であれば「資格は不要」と説明し、特別教育が必要なことを説明されていないケースも耳にします。

次に「Ⅱ. 安全衛生教育の効果」（篠原資料9頁）です。安全衛生教育はやはり雇入れ時教育と作業内容変更時教育が非常に重要です。雇入れたときに安全教育を実施するのは当然で、作業内容を変更したときも安全教育が必要になります。篠原資料9頁に以下の事例を掲載しました。

令和2年7月6日、北海道のごみ焼却施設で塩素ガスが発生し、男性作業員5人が救急搬送されたがいずれも軽症。洗浄水をろ過する装置に次亜塩素酸ソーダを補充する際に、作業員が誤って塩酸を投入したため、2つの薬剤が反応し、塩素ガスが発生した。

作業員は作業手順書を確認せず、塩酸を入れると思い込んで作業をしていたという。

5人のうち2人は事故対応に当たっており、空気の供給を受けるマスクを着用していたが、使い方を誤ってガスを吸引した模様。（労働安全衛生広報 2020年9月15日）

これだけでも、雇入れ時教育の項目に関する留意点がいくつか出てきて、まず「混ぜるな危険！」です。どの溶液や溶剤を混ぜると危険なのか、化学式を用いて説明し、私もお話することがあります。この事例では、化学物質の有害性について適切に教育したのか、あるいは保護具の性能や取扱いについて十分な教育がなされたのか、また作業手順に関する事、作業開始時の点検、当該業務に関して発生するおそれのある疾病の原因及び予防に関する事（この事案では塩素を吸いこんだらどうなるかなどといったこと）、あるいは応急処置などなど、適切に教育していれば事故は起きません。しかし、これがきち



んとなされていない会社も見受けられます。

「2. 雇入れ時、作業内容変更時教育の特徴」として、(1) 事業場の規模、労働者の雇用形態、雇用期間に関わらず実施しなければならないので、1日だけ雇用するアルバイトにも実施することが必要です。また、(2) 教育に要する時間は決まっていないということです。必要な内容、時間を決め、理解度を確認し、作業許可を出している例も現場ではあります。そして、(3) 記録の保存義務がないことです。雇入れ時の安全衛生教育は罰則付きの義務でありながら、記録の保存義務がありません。ここは少々問題なのではないかと思えます。なので、理解度も含め教育記録は作成、保存すべきであると考えます。これがあれば、行政機関も含め定期的にチェックすることが可能になります。篠原資料10頁に災害事故の例を挙げましたが、作業内容変更時に教育を実施していなかったのですが、死亡事故が起きると安全衛生教育の問題がクローズアップされ、司法処分の対象となりますので、なおさら教育実施に関する記録とその保存は重要なのではないかと考えます。

どのような教育が効果的であったかについては、言うまでもなく「過去の災害事例及び現場での作業手順の活用が効果的」だということです。複数の企業の新入社員向けに安全衛生の基礎教育を行うことがあり、いろいろな会社の若手や新入社員の方々を集めて実施するのですが、その際には一つ一つ、基本事項を説明しては災害事例を挙げながらの教育になります。一つの企業だけを対象とする場合、過去の災害分析（事故の型、年齢別等）、また会社の中でその災害を受けて実施した対策などをお話します。いろいろな事故が起きますので、時折悲鳴が聞こえるような内容になりますが、典型的な過去の災害分析を行い、それに基づいた対策について説明することになります。管理監督者を対象とする場合もありますが、その際には事前に現場巡視（パトロール）を実施し、好事例も伝え、要改善点をできるだけ前向きに解説します。あまり後ろ向き話ばかりすると、「やらされ感」になってしまいますので、生産性と安全をリンクさせながら、「よくできています」にプラスアルファをお勧めするような前向きな教育が効果的だと思います。もう一つには、明瞭で分かり易く、長々説明するより写真や図を用いてお話します。特にルールや対策を立てるときには、なぜそのルールや対策が必要なのか、どのような悲惨な事故や過去の教訓に基づいて必要になったのか、それらをきちっと伝えるようにしています。

以上、報告を終わらせていただきます。

三柴 ありがとうございます。このプロジェクト自体、事例でみる生きた安衛法という理念で進めたいと思っていますし、発刊する予定の体系書もそういう内容にしたいと思っています。そういう前提ゆえ、今のご報告は非常にありがたいと思います。先生方からご質問、コメント等ありましたらお願いいたします。

角田 ご報告ありがとうございます。私の方でも特別教育を実施しておりますので、大変参考になりました。安全教育においてその効果を測定・記録するというお話がありました。確かに教育を実施してもどれほど伝わっているのか、あるいはどれだけ実践されているのか、なかなか測りにくいところがありますが、今までどのような形で安全教育の効果や理解度などを測ってきたのでしょうか。

篠原 私が効果を測定するのは、だいたい職長教育と雇入れ時教育を行う場合ですが、各教育の最後の段階で重要な部分についてはテストをしてその出来具合を、たとえば「非常によく分かっている」「よく

分かっている」「理解できていない」など、項目ごとに判定し出来不出来を評価し、会社にフィードバックします。会社の中には、リーダーの人が実地で実務教育をされて、項目ごとに出来具合をチェックし、出来具合が悪いと作業許可を出さない例もあります。また、スマートフォンで簡単に情報を共有できるビジネスチャットを活用して、誰が作業許可が得られているのかいないのか、全社で共有している事例もあります。

角田 ありがとうございます。参考にさせていただきます。

三柴 ありがとうございます。篠原先生のご報告についてはここまでということで、次に私の方から現在進めている調査について報告させていただき、その後法学者グループから分担報告書の経過報告をしていただきたいと思います。

画面共有でお見せしているのは、すでにMLで共有させていただいたエクセル資料ですが（※以下「三柴資料1」とする）、私が実施した調査は行政官・元行政官向けに安衛法令の条文に関わる事例を教えるためだけの調査であり、あわせて改正を要する点、そして専門家が専門的に検討すべき点についてもお尋ねしています。もう一つ配布させていただいた「質問文」と題したファイル（以下「三柴資料2」とする）の1頁に記載したとおり、まず調査の趣旨と本プロジェクトの趣旨をお伝えし、安衛法のどの条文に適用された事例かを記載していただき、事例の内容を情報としてお知らせいただく形になっています。もちろん守秘義務がありますので、それに抵触しない限りで抽象化した情報を提供していただきました。安衛法本法の条文に関わる事例のほか、省令に関わる事例もお尋ねしました。それから、先ほども申しました通り、専門家が本格的に検討すべきと思われる安衛法上の課題についていくつかの選択肢を提示してお尋ねしました。また、安衛法において改正が必要な点があれば、改正案とともにお知らせいただきました。

現時点での集計は三柴資料1に記載したとおりで、本法関係については概ねこのような感じで情報をいただきました。エクセル表に記載している数字が条文の番号を表しています。作業環境測定法についても、20条から32条に至る条文に関する事例をいただきました。省令関係では、やはり安衛則とクレーン則が中心です。現在、私のアシスタントが集計を行っており、Wordファイルになると思いますが、その方が検索をかけやすく便利だろうと思います。完成次第共有しますので、法学者・行政学者の先生方におかれては、そこから得られる情報を分担報告書のフォーマットのうち「適用の実際」の項目に盛り込んでいただきたいと思います。この調査は、計300か所ほどの都道府県労働局、監督署、安全衛生の関係団体に一斉送信して、回答に手間がかかる質問な上に守秘義務にも抵触しかねないので、回答の数はあまり多く集まらないと思っていましたが、「お答えできません」という趣旨の回答も含め70か所ほどから返信がありました。その背景には、本省から調査協力をするよう通知を出してもらったという事情もあります。

では、次いで分担報告者に経過報告をしていただきたいと思います。まずは石崎先生からお願いいたします。

石崎 分担報告書につきましては、提出が遅れて大変申し訳ありません。進捗としては、これからさらに追いついていかなければならない状況ですが、目下検討作業に取り組んでいる箇所の概要を紹介させて

いただき、調査の過程で若干の疑問が生じる部分が出ましたので、その点についてご相談させていただければと思います。

昨年度は作業環境測定を中心に書き進めてきましたが、その中で加筆した点を中止にお話しさせていただければと思います。作業環境測定を行う作業場については、安衛法施行令に列挙されていますが、その条文だけでは今一つイメージがわからないということもあり、それぞれの作業場における有害要因や障害の形態などを示すことができないかと考え、図表を後につけさせていただくことにしました。すなわち、どのような有害要因があり、それがどのような形態の障害を生むリスクがあり、どういう業態でそういうリスクがあるのか、といった内容を示す図表を掲載しました。また、著しく暑熱つまり暑い作業場との関係で施行にかかる図表も見つけたのでこれも追加し、また騒音が発生する作業場との関係で「ドラム缶洗浄」というものが少々分からなかったのですが、これに関する写真を見つけたのでこれも報告書の中に掲載する予定です。さらに林業関係のドラム・パーカーやチップ、紙漉きの過程で紙を乾かす工程に関する図表を追加しています。この他、放射線業務の関係で少々追加し、特定化学物質についてどの程度まで私の担当条文のテーマとして説明するかという問題はあるものの、第一類物質や第二類物質の分類などについても説明を追加しました。今回調べていて、放射線濃度の測定についても加筆してみましたが、私自身今ひとつ把握しきれていない点があるので、色々ご教示いただければと思います。特に、各種測定器については日本電気計測器工業会のWebサイト等から写真を確認することができましたが、作業環境測定基準の中に分析方法として、基本的に蛍光光度分析方法などがあるようですが、その一方で空気中のガス状の放射性物質濃度の測定については、直接濃度指示方法によることができるという規定が設けられており、これはおそらく有機溶剤であれば検知管のようなより簡易な方法で測定できるというものと推測できますが、直接濃度指示方法というのがどのような方法で使用する機器に何か違いが出てくるのかどうか、調べた限りではよく分からなかったので、ご存知の先生がいらしたらこの辺りについてご教示いただけると幸いです。また、昨年フォローできていなかった個人サンプリングに関する記述などを追加している点が、作業環境測定に関する条文における加筆部分です。

続けて、第65条の3の作業管理の話になりますが、この条文は努力義務で短い条文であり、どこまで掘り下げるべきかという問題もあるのですが、作業管理については指針やガイドライン等で詳細が定められ、そのうちどれを取り上げるのが適切かについてもご相談させていただければと思います。背景災害としてキーパンチャーの事例を取り上げようと考えていますが、現行のガイドラインとしてはVDT作業（現在は情報機器作業）における労働衛生管理のためのガイドラインがあり、そこでは3管理についての定めがありますが、作業管理についての詳細な規定があるためにその内容を紹介したり、また腰痛予防対策の指針の内容も取り上げているところです。沿革としては、この規定は第7次労働災害防止計画の頃になされた安衛法改正によって追加された規定ですが、そこでVDT作業に関する問題が指摘されていたところなので、ガイドラインの変遷や先ほど取り上げた腰痛予防指針の展開についても記述しています。背景災害はご承知のようにキーパンチャーの頸肩腕症候群で、これを苦にした自殺が社会問題化したことなどを取り上げています。安衛法第65条の3は電通事件判決の中でも引用され、下級審では腰痛予防対策指針の内容に触れたうえで安全配慮義務の内容を定める基準となる旨述べている事案もあり、これらを紹介します。

現在進めている部分については以上のとおりですが、もう一点ご相談させていただきたい内容があります。安衛法第65条の4の作業時間の制限に関する規定ですが、厚労省令である高圧則では、高圧作業

や潜水業務などで作業に従事する時間を制限する旨の規定が以前は設けられていました。調べてみると、平成27年の改正で、作業時間の制限について従前はかなり細かな規定があったようですが、改正による新规定では事業者が作業計画を策定することを義務付けられるようになりました。その中で作業時間については事業者が作業計画の中で定める内容が変わっています。以前は減圧表で時間が決まっていたようなのですが、計算式を導入して作業時間を設定するような形が変わっています。そうすると、安衛法における作業時間は、「安衛法に基づいて制限されている」という理解でよろしいのか、それとも安衛法が規律する作業時間の制限がなくなったとみることになるのか、その辺りについてご教示いただければと思います。つまり、従前は安衛法が高圧則に委任する形で作業時間の制限規定を設けていたため、これを「作業時間は安衛法に基づいて制限されている」と理解して間違いはないと思われそうですが、改正高圧則によって、作業時間は各事業者が一定の計算式に基づいて作業計画の中で定めることになったようです。こういう規定の下においても、「作業時間は安衛法に基づいて制限されている」とみていいのか、判断に迷っているところです。

三柴 ありがとうございます。高圧則に基づく計画的な対応までもが、安衛法に基づくものと理解していいのか、という疑問でしょうか。

石崎 あるいは、安衛法に基づく規制が消えて、現在は「高圧則に基づく規制」だけが残っているとみるべきなのか。

三柴 高圧則に基づく作業計画と本法である安衛法との関係がどうなっているか、ということでしょうか。

石崎 その通りです。

三柴 ご報告ありがとうございます。石崎先生のご報告の中で、2点ほどお尋ねがありました。一つは放射能の計測の方法について、もう一つは高圧則に基づく計画と安衛法との関係です。これらの点について、お答えいただける先生はいらっしゃらないでしょうか。

唐沢 電離放射線の分析用機器についてはあまり詳しくないので、高圧則のお話をさせていただきます。ご報告にもありましたように高圧則は改正されていますが、これはやはり、安衛法の作業時間の規制の条文に基づく形になっていると思います。ですから、省令としての高圧則が単独で走っているわけではなく、安衛法に基づく規則ということで規制基準になっていると思います。要は、計算式によって算出された作業時間を遵守しなければならない、ということになると思います。

石崎 ありがとうございます。

三柴 この会合の映像記録は本日ご参加いただけない先生方にもご覧になるので、そういう方への呼びかけとして、放射能の問題も含めお答えが可能でしたらMLに共有をお願いできればと思います。ある



いは石崎先生の方でお答えできそうな先生がいらしたら、その方に直接お尋ねしていただいても結構です。放射能の問題は、あるいは行政にお聴きになってみるのもいいかもしれません。電離放射線については本省に担当部署がありますので、おそらく回答を得られるのではないかと思います。

それでは、石崎先生のご報告はここまでとしまして、次は長谷川先生、お願いします。

長谷川 事前にお配りした報告用項目メモ（以下「長谷川資料」とする）をもとに、現在どのようなことに取り組んでいるか、また先生方にお伺いしたい点等について手短にお話をさせていただければと思います。本研究会では初めて報告させていただきます。今回先生方にお目通しいただいているこのデータも、おそらく初めてのものかと思えます。まずはどのような内容をまとめたかをお話すべきかと考え、長谷川資料を作成した次第です。

まず「1 調査内容について」をご覧ください。私が担当しているのは、安衛法第55条から第58条の化学物質関連の条文です。これらがどのような条文になっているかについて、私の報告書（以下「長谷川報告書」とする）の2～4頁にまとめています。長谷川報告書は共有画面に映っているとおりですが、ご覧のように三柴先生ご指定の形式に即してまとめたもので、ぜひ先生方にお目通しいただければと思います。特に、今後ご相談させていただく現場の実態など、お気づきの点がありましたらご意見いただきたいというのが、今回の報告の趣旨でございます。長谷川報告書はPDFのしおり機能を使えるようにしておりますのでご利用ください。

概要のところですが、化学物質に関する規制を全体として整理しているところです。どういう枠組みになっているかと言えば、長谷川報告書4頁の「【前注・資料1】労働安全衛生法に基づく化学物質に対する規制の体系」をご覧ください。ベースには製造禁止があり、次に高リスクではあるけれども、リスクを軽減・縮小させる取組みの機会等を用意しているものを許可制の下に置きます。これよりも危険性・有害性の低い一定の化学物質については、取扱い上の注意を表示させ、あるいは文書交付をさせ、また現場で実際に使用する際にはリスクアセスメントを実施させ、有害性の調査を行わせるなどといった形で、危害防止の実現が図られています。報告書のまとめ方としては、長谷川資料1頁の概要のところに記載したとおり、コンメンタールの整理をしました。私の担当箇所である化学物質に関しては、他に担当されている先生もいらっしゃるのですが、体系書が公刊されたときにこの条文がどういう解釈になっているのかに関心を持つ人もいると思われるので、コンメンタールの書き方をしています。三柴先生のご方針が現場の実態に即して調査・執筆するということなので、その部分についてはなるべく図説を用いながら実態について書き加えていく努力をしております。

実はこのテーマに取り組むのは初めてなのですが、化学物質を単純に規制しているのかと思ったら、長谷川資料1頁に「展開傾向」と書きましたが、単に製造を禁止するばかりではなく、流通のプロセスやつながり、そして現場での対応なども含め、流れのある履行確保の仕方がなされているのが印象的でした。当然、その場その場ごとの履行確保はどうなっているのかが論点になるわけで、たとえばリスクアセスメントなどをどう実行してゆくのか、一般的なリスクアセスメントに限らず化学物質については専門的能力のある人材が必要になりますので、そういった点も問題になってくると思います。もう一点、規制方法が国際的な影響を受けており、他国と同じような規制をしなければならないという点も非常に興味深いところでした。この点については実態を記述する箇所当該条文の運用や制定に関わるポイント（条約なども含め）を書くことで、これまでのコンメンタールとの差別化が図れるのではないかと思います。

長谷川資料1頁「2. 今後追記すること（と教えていただきたいこと）」ですが、一つ目は建設アスベスト訴訟について少々書いてみたいと思います。安衛法第55条に関連し、第57条にも関連してくると思いますが、ご承知のように先般最高裁の決定が出たところなので、判旨の中でどのようなことが述べられたのか整理しておきたいと思います。二つ目は、時間の都合上調査しきれていない点ですが、各条文の民事的効力をどう解釈するかという問題について少々悩んでおります。できる限り多くの文献を当たって調べているところですが、なかなかこれというものが見つかりません。個人的にはどう解釈すべきか一応の考えはあるのですが、裏付けが欲しいところなので、現在検討しているところです。三つ目が今回先生方に直接お伺いしたい点なのですが、三柴先生から各条文ごとに背景となった災害や適用の実際を整理すべきであるというご指示を受けております。この点について漏れがないか、あるいは別途こういうことも書くべきではないか、などといった点についてご意見いただければということです。今回私がまとめた事項について、あくまで概要ではありますが、長谷川資料1頁、2の枠内にテーマを書き出しました。長谷川報告書でもご覧いただけます。内容を簡単に紹介させていただきますと、製造禁止（第55条）については、ベンゼン中毒事件つまりヘップサンダル事件のほか、建設アスベスト訴訟なども製造禁止の議論の背景となった事件として挙げられます。すでに安衛法上製造禁止のルールは出来ていますが、解体工事などを通じて石綿被害の問題が生じていることも書いてみたいと思います。先般、ニトリの足拭きマットの中にもアスベストが含まれていることがニュースになり、わが家で使っていたものもそうであったことが判明し、非常に身近な問題であると思われまます。第56条は製造許可の規定ですが、玉泉先生や篠原先生にご協力いただきまして、その内容も踏まえて上で書いておりますが、調べた限りでは実態についてはあまり議論になっていないようです。第57条はラベルの表示等の規定ですが、改正のプロセスが問題となりました。背景には六価クロム事件やGHSのような事情が窺われます。ラベルについては近年はあまり問題になっていないものとうかがっています。ラベルの運用実態については、行政通達（昭和47年9月29日基発第634号）が出されています。文書の交付等（第57条の2）については、背景事情としてここに記載した条約のほか、和歌山毒物カレー事件で顕在化した毒物に関する問題などがあり、実態としてはここに記載したとおり、「職場のあんぜんサイト」を中心に様々な情報提供がなされています。リスクアセスメント（第57条の3）については、比較的多くの情報がありまして、胆管癌事件が背景にあったということもよく知られています。実態としては、化学物質等による危険性又は有害性等の調査等に関する指針、また厚生労働省版コントロール・バンディング等により様々な情報提供がなされています。第57条の4の有害性の調査については、化学物質の審査及び製造等の規制に関する法律などが関わって明文化がなされ、厚労省Webページに手続等が集約されているという情報を入手しています。

明確な情報が見つからず、理解が未だ不十分なのは最後の2つの条文、すなわち、第57条の5および第58条についてです。前者は有害性の調査に関する指示についての条文ですが、あまり先行研究は多くないようです。後者については、日本バイオアッセイ研究センターが援助をサポートする仕組みとして設けられていることは明らかですが、これ以外の点で何があるのだろうかというところです。

非常にシンプルではありますが、私が現在取り組んでいるのは以上のとおりです。何分初めての調査ゆえ、至らない点も多いかと思われまますので、ぜひとも先生方のお知恵を拝借できればと考えております。

三柴 ありがとうございます。初めてと仰りながら大変ていねいに調べていただいているようで、ありがたく思います。私の方から、現在進行形の政策の変更に関する情報を少々お伝えしますと、まずピラミッド型の化学物質の分類(長谷川報告書4頁)についてのお話があります。これは安全衛生行政がこれまでしばしば示してきたものなのですが、この図の下の方にある物質については“危険ではない”という誤ったメッセージを与えてしまうのではないかと懸念から、上下ではなく左右にフラットに並べて分類し直そうという動きが、現在検討会の中で進んでいます。ピラミッド型の図の中で下の方に位置するものは、有害性等が“未解明”というだけであって、危なくないということではないということです。それを示すのが以下の図です。

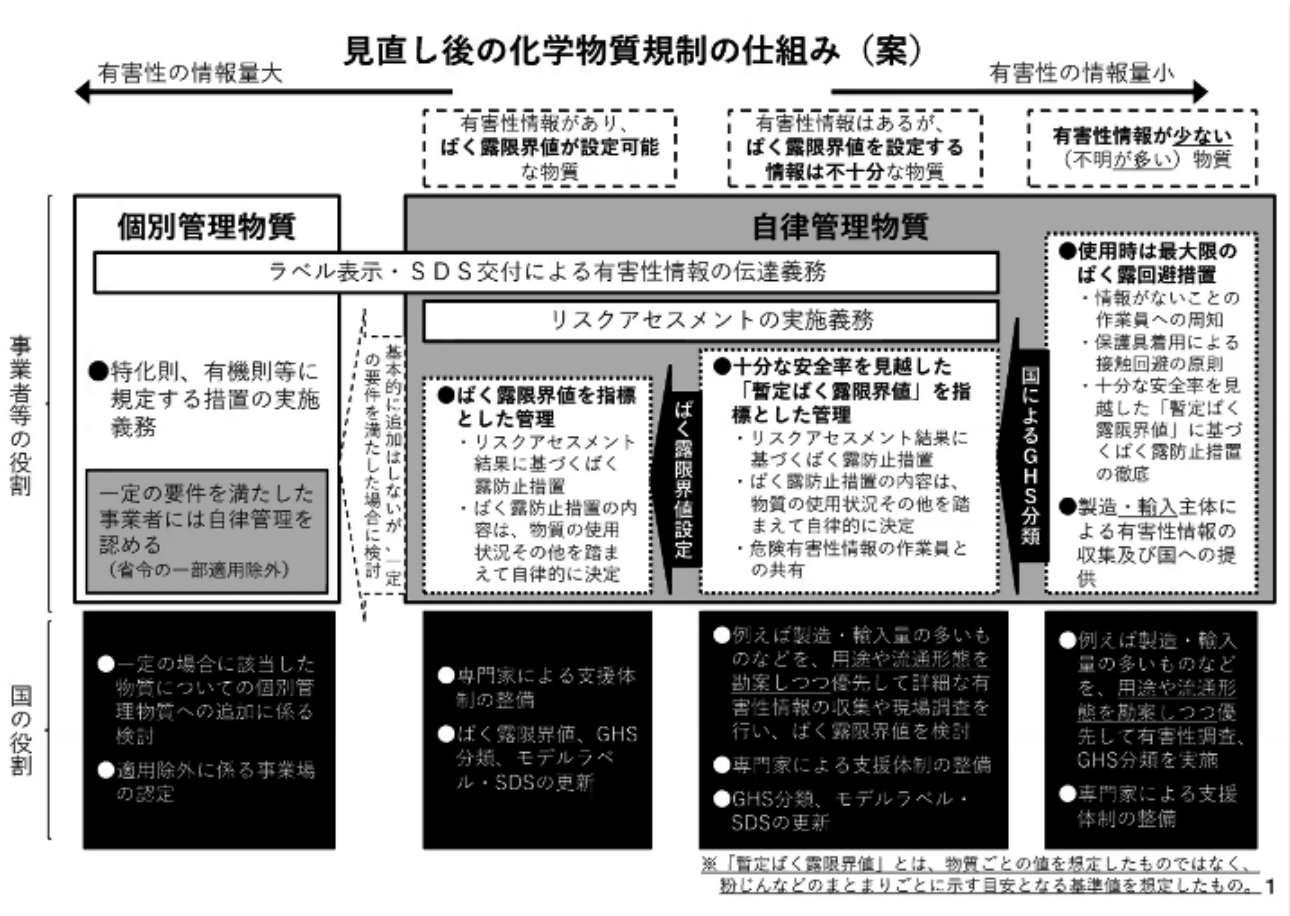

これらは、現在行われている「職場の化学物質管理に関する検討会」のWebサイト ([https://www.mhlw.go.jp/stf/newpage\\_06355.html](https://www.mhlw.go.jp/stf/newpage_06355.html)) をご覧いただくと、その資料の中に掲載されています。見つからなければ私にご連絡いただければ、公表されている範囲でお伝えします。

また、省令改正レベルにとどまりそうなのですが、化学物質管理の在り方をかなり大きく変えていこうという動きが進んでいます。先ほど長谷川先生も仰っていたように、化学物質は危険だから全部取り扱いや製造を禁止するというのであれば、産業が死んでしまいます。さりとて、基本的には危険であるという認識を欠くと被災者を生んでしまいます。その中で両者のバランスをどのようにラインどりしてゆくかが非常に悩ましいところです。一方では産業利益であったり、現場での評価・管理ができるかということに気にならなければいけません。他方では、危ないかもしれないという認識の下でグレーゾーンについても必要な対策をうっていかねばなりません。そういう両義的な対策が求められる領域というわ



けです。また、規制の内容も成熟させていかなければなりません。全部禁止でもなく全部野放しでもなく、その方向性のひとつとして「リスク」に基づいた対策、つまり単に有害だからダメということではなく、上手く取扱えば有用になるわけで、そういった点も併せ考えるのが「リスク」という概念です。「ハザード」がその物質自体が持っている有害性だとすると、リスクはそれを上手く取扱うことができれば管理ができるという発想です。なので、リスクに基づいた対策を打っていこうという方向に進んでいまして、上の図が示しているように、リスクに応じた対策ということになると、たとえば物質を海外から輸入したり、新しく製造したりする際に、それを流通させる分量によって、つまり何t以上は「リスクが高い」として規制を強化するといった方法のほうがよろしいのではないかと。そういう方向で議論が進められています。この辺りは私から説明するよりも、唐沢先生や森先生の方が的確なご説明をいただけるかと思いますが、私も委員として参加しておりますので、私から申し上げられる点について説明させていただいた次第です。

では、長谷川先生から提示されたご質問への回答も含め、お答えいただける先生からお願いできますでしょうか。

森 ご報告ありがとうございました。先ほど様々な災害事故を基にどのような条文が制定されたかというお話がありましたが、私も化学物質災害についていろいろ調べてみましたところ、出てくるのは急性中毒ばかりで、化学物質がらみで裁判になった事案はさほど出てきませんでした。一方で、化学物質については毒性試験がかなり実施され、特に発がん性に関してはICRP（国際放射線防護委員会）が定期的に発がん性の可能性や頻度などをアップデートしているので、エビデンスに基づいて動くという傾向にあります。たとえば製造禁止ないし製造許可の物質には色素系の物質が多く含まれていますが、それは膀胱がんが発生した事例に基づいています。その中にβナフチルアミンという物質がありますが、それに近い化学物質であるαナフチルアミンは製造許可物質です。結局これも、βナフチルアミンの発がん性を考えると、かなり近い形の発がん性や生殖細胞変異原性があるということで、予防的に製造許可を要することにしており、こういう物質は相当数あると思います。最近、特化則に規制対象物質が追加された際にも、必ずしもそれによって健康障害が生じたというよりも、海外の疫学的研究成果に基づいている場合もありますので、化学物質規制については事故のみを契機とした規制を探し出すのは難しいのではないかと思います。とはいえ、一つ一つの物質が何を契機に規制対象となったのかを追跡するのは相当に大変な作業かと思えます。最近の事例は、未規制物質が原因で発生しているものがかなりあります。たとえば保護衣や保護手袋の装着義務という形で規制がかかったのは、オルトリジンなどです。ばく露状況をみると空気中の濃度はさほど高くはない場所で就労している人に膀胱がんが発生したのがきっかけです。もともとこれは経皮吸収のある物質ゆえに蓋然性も高く、本来ならもっと早くから規制されるべきであったのですが、これを契機に規制対象となりました。このように、研究的アプローチをきっかけに規制がなされることもあるので、背景災害を調査するのは難しい要因がそこにあるかと思われま

す。もう一点、先ほど三柴先生が仰った現在の流れの中で、我々の学会も意見を出したりすることもあります。化学物質のうち「その他の化学物質」になるほど情報が少なくなってくるにもかかわらず、今の規制の方法では、規制のない物質つまり「危険かもしれないが何の規制もない物質」を使用した方がコストが安くて済むので、こういうやり方をすると規制をかければかけるほど、情報のない物質が使用されるようになります。この辺りのことを調整する必要があるということが、内々に議論になっているよう



です。

三柴 ありがとうございました。唐沢先生からもコメントいただけないでしょうか。

唐沢 私の言わんとすることは、先ほど森先生がほとんど指摘して下さったところです。

三柴 ありがとうございます。森先生のお話につなげさせていただくと、昨日このテーマに関連する検討会にて同様のことをお話しましたが、学問的規制の代表格はドイツです。ドイツの場合、学問的に危険だと判明した物質に規制をかけていくスタイルです。以前、ドイツにおける規制の基本原理について調べたことがあるのですが、特に危険かどうかグレーゾーンについてどういう規制をしているかを調査しました。大きく分けて3種類あって、学会における支配的見解として危険だとされるもの、その真逆で一部の有力説のみが危険と判断し、ほぼ直観レベルで危険とされているにすぎないもの、そしてその中間にあるものです。そしてそれぞれについて、民間の研究団体や業界が定めている規格を法制度上に組み込む形で規制をかけていきます。そうすると、専門家が比較的危ないと認めたものについて部分的に規制をかけるというスタイルになります。ただ、ドイツはヨーロッパの一国なので、基本的にリスクアセスメントは義務になっていて、すべての化学物質について実施しなければなりません。それを前提に、リスクアセスメントを実際にどう運用するかという点においては、学問的、科学的に危険と判断されなければ規制は及びません。唐沢先生はお詳しいと思いますが、ドイツの場合災害保険組合が労災補償のデータしかとっていないのですが、化学物質関係の被災は多いのではないかと思います。ドイツは労災保険の仕組みで労災と疑わしいものも申告するという前提をとっているので、補償の局面でグレーゾーンの部分を相当数救い上げている可能性があります。さらに、労災保険の認定の仕組みが社会民主主義的に労使の話し合いによって決定される形になっているので、結局サイエンスをベースにしつつ最終的にはコンセンサスによって労災の予防・補償の在り方を決めていきます。

日本の場合どのようにしてゆくべきか、ドイツの例も参考にしながら適正ラインを考えていかなければならないと思います。

では長谷川先生のご報告はここまでということで、いったん休憩時間を取りたいと思います。

三柴 再開させていただきます。まず愛知産業保健総合支援センター（愛知産保センター）の副所長をおつとめの久保先生からご報告をいただきたいと思います。テーマは化学物質管理に関する監督指導現場の実態です。それでは、よろしくお願ひします。

久保 こんにちは。愛知産業保健総合支援センターの久保と申します。私は平成5年に労働基準監督官に任官しましたが、それまでは神奈川県内の作業環境測定機関に作業環境測定士として勤務していました。労働省（当時）に入省し、平成8～9年度には霞が関の安全衛生部環境改善室にて有機則や粉じん則の改正作業に従事しておりました。その後、直近では平成28年度に一宮労働基準監督署で第2方面主任監督官、平成29年度は愛知労働局労働基準部監督課にて特別司法監督官、平成30年度は健康課にて労働衛生専門官をつとめ、平成31年4月から現職でございます。この間、労働衛生コンサルタント（衛生工学）に合格しております。

ご依頼のありましたテーマは「労働基準監督官について」です（※報告に使用されたPPおよび同一内容のPDF資料を以下「久保資料」とする）。まず、労働基準監督官の採用枠は「A採用」と「B採用」の2種類に分かれ、A採用が文系の採用、B採用が技術系の採用で、両者はだいたい7：3くらいの割合で採用されているようですが、2020年度の募集要項をみると、B採用が45名、全体で230名ということで、現在B採用の割合が2割を切っている状況です。つまり、技術系の分野が得意でない人材が多く占めるということです。にもかかわらず、任官後に従事する仕事は基本的には同じもので、特に最近厚生労働省労働基準局では人事計画の方針が最近変わって、地方技官（専門官）の採用を中止し、その分労働基準監督官の採用数を増やしています。そのため、A採用の監督官が所轄労働基準監督署の安全衛生課長（第二課長に配属されたりすることもおきていて、そういう方が特定機械の検査などにも従事することがあるということです。

私が採用された平成5年頃は、全体で100名程度の採用人数でしたが、最近では毎年200名以上が採用され続け、その結果、これまで国家公務員の定員削減を年々実施してきたことにより、所轄労働基準監督署の平（ひら）監督官ポストが、採用1年目から3年目の監督官で埋まり、OJTが十分にできていないように見受けられます。つまり、上司が部下を教育できない状況が発生しているのではないかとということです。なおかつ、平成30年度の全国の労働基準監督署による労基法及び安衛法違反被疑事件の送致件数は896件。このうち、労働安全衛生法違反被疑事件が59%、労働基準法・最低賃金法違反被疑事件が41%であるということですが、本当に適切な捜査ができていないのか懸念される状況です。

三柴 久保先生、今しがた上司による部下の指導がしにくくなっているとのことでしたが、その背景が少々分かりにくかったのですが、もう一度ご説明いただけないでしょうか。

久保 要は、平の監督官の数は多いにもかかわらず、彼らを指導する管理職の人数が少ない状態ということです。その中間のちょうど働き盛りの世代が出先機関になかなかいない状況が発生しています。

三柴 了解です。ありがとうございます。

久保 久保資料6頁に移ります。監督指導に行く際には、原則一名で監督に行きます。そして、アポ

なしで突然伺うということが行なわれているはずですが。当然、化学が苦手な監督官もいます。そのため、監督指導計画の中に化学物質のほかに一般労働条件その他諸々のテーマがある場合には、化学に関する監督指導はどうしても後回しになってしまうという傾向になりがちです。当然、事業場の担当者の方が知識が多いこともあります。

化学物質の監督指導に関して、労働省（当時）は平成10年ごろ、「有害物質に関する監督指導は、一定程度、完了した。今後は、一般労働条件監督を主として監督指導を実施していく。」という方針を打ち出していました。私は個人的には「何と傲慢なんだ。」と感じていましたが、その後、立て続けにゴミ焼却施設の解体作業に従事した方の血中ダイオキシン類濃度が高いということが話題になり、また先ほども出てきましたが、1,2-ジクロロプロパンばく露による胆管癌、あるいは $\alpha$ -トルイジンやMOCAによる膀胱癌などが発生し、厚生労働省の方針をあざ笑うかのように化学物質による健康障害等が明らかになり、現在に至っています。

化学物質による健康障害防止を主眼とする監督指導は、主として大久保資料9頁記載の事項を確認するものです。まずは作業内容です。粉じん、鉛、有機溶剤は、作業列挙方式になっていますから、どのような作業をしているのかを確認します。それから、化学物質のラベルを見せてもらってどういう成分が含まれているのか、SDSはあるのか、労働衛生保護具はどのようなものを使っているのか、そして作業環境測定結果を確認する、局所排気装置等自主点検結果や特殊健康診断結果をみる、また時間外労働時間数を確認する、といったことを主に実施します。当然、そのほかの分野の監督指導を行なうことがありますので、これ以外の事項について監督指導を受けることがあってもご了承ください。

日本の労働基準監督官は、「製造現場等で労働者が化学物質にばく露していないか」を確認に行っているわけではありません。あくまで、労働者が化学物質にばく露しないために規定された「法令の遵守状況」を確認に行っているということです。つまり、法令の想定を超えた状況には対応できないのです。遵守状況の確認なので、「違反か」、「違反でないか」の判断しかしていません。違反にならないために（技術的に）何をしたらよいかは、監督指導の範囲外となります。例えば、労働安全衛生法施行令別表9には、700近い化学物質が列挙されていますが、おそらく現役の労働基準監督官でこれらをすべて把握している者はいないであろうし、どのような性質で、どのような危険性・有害性があるか、ばく露経路はどれかなど、おそらく誰も把握していないのではないかと思います。労働基準監督官をはじめとする職員に、化学物質の参考資料など配布されているわけではありません。例えば、NIOSHは、**Pocket Guide to Chemical Hazards** という冊子（？）を発行していますが、以前はワイヤ製本された分厚い冊子でしたが、現在はダウンロード可能な電子ファイルとなっています（<https://www.cdc.gov/niosh/npg/downloadable.html>）。大久保資料13頁は、先ほども話に出ましたMOCAの部分を抜粋したものです。**Pocket Guide to Chemical Hazards** のすごいところは、化学物質ごとに、基本的なデータ、慣用名、濃度基準、測定方法、物理化学的特徴、保護具、呼吸用保護具、ばく露経路、ファーストエイドが、1ページの半分にすべて集約されていて、約670物質がデータ化されています。これが、NIOSHのホームページに公開されており、日本に住んでいても無料で自由にダウンロードすることが可能で、スマートフォン版も有ります。また、IDLHの記載があることも特筆すべきところではあります。

そうはいつても、「SDSがあるじゃないか」という反論があるかもしれません。しかし、平成28年「労働安全衛生調査（実態調査）」によると化学物質を製造又は譲渡・提供している事業所のうち、製造

又は譲渡・提供する際にSDSを全て交付している割合は、49.1%となっています。また、同じ統計で化学物質を使用している事業所のうち、SDSが全て交付されている事業所の割合は、54.5%しか存在しないという状況です。また、私どもが事業所に伺うと、「SDSコレクター」ばかりです。集めることだけが仕事になっていて、記載されている情報を有効に活用している事業所は、ほとんどないと思います。収集したSDSは、大切に担当者にしかわからない場所に保存されている例をよく見受けます。私どもがSDSがあるかを尋ねると、あると答えるのですが、では見せてくださいと言うと、“本日は担当がお休みなので、どこにあるかわかりません”といった状況がしばしばです。要するに、SDSを集めているからいいじゃないかというスタンスが多いのです。そういう場合、私は“ならばこの一斗缶を今から足で引っ掛けて倒しますから、その後どう片付けますか”と尋ねると、“すぐに拭き取ります”。では、“手袋はどういうものを使いますか、呼吸保護はどのようにしますか”と尋ねると、返答に詰まります。なので、“SDSに書かれていることを有効活用すればそれに答えられるはずですよ”と言ったやり取りをすることになります。しかし、そこまでSDSを活用している事業者は稀であると認識しています。また、化学物質の危険性・有害性情報は、新たな知見が得られればSDSも更新されるのですが、いったん集めてしまうとSDSの更新をしている事業所は少ないです。

また、実はSDSそのものもいい加減な例もあります。大久保資料17頁以下はある印刷工場で見つけたSDS（オフセット印刷のブラケットの洗浄・復元剤のスプレー缶）の写しです。一部黒塗りにしていますが、これを拡大すると、以下ようになります。

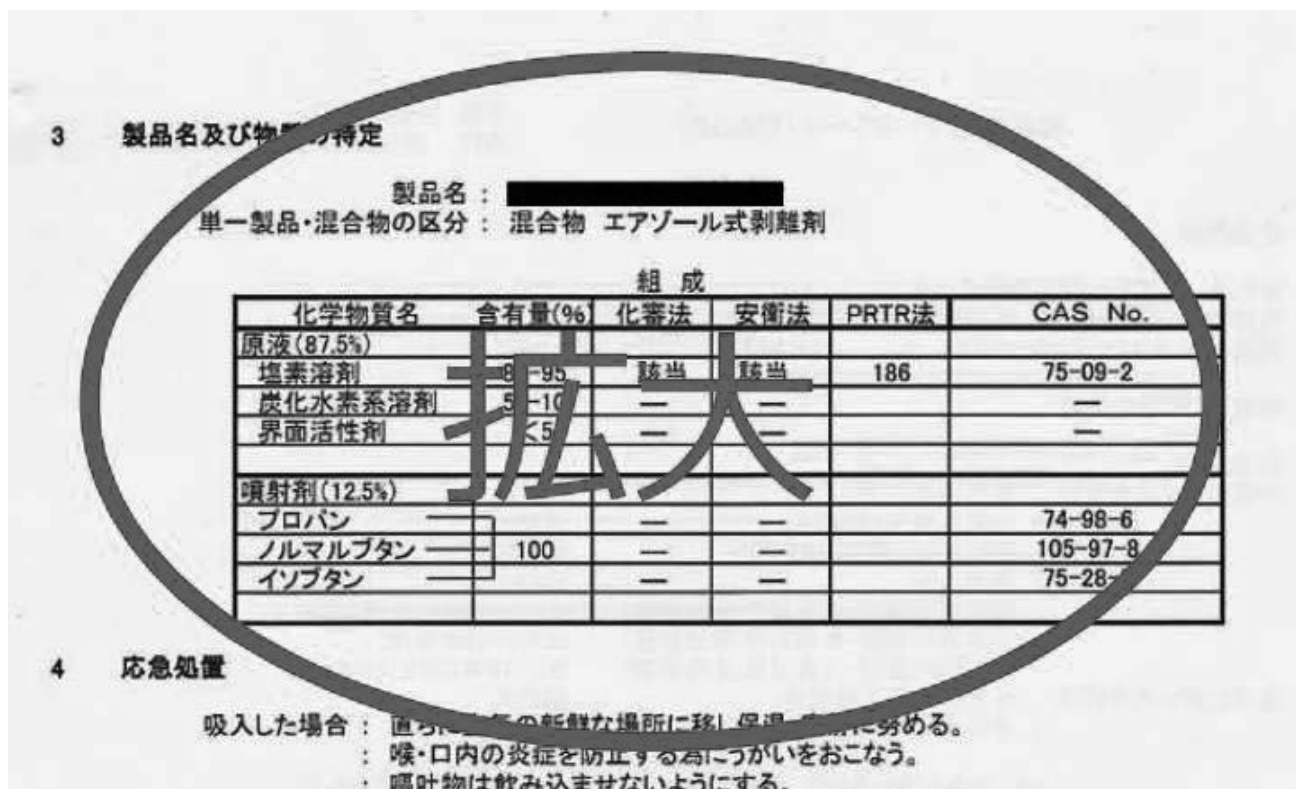

「原液」の「塩素溶剤」の含有率が85～95%、化審法、安衛法いずれも該当、PRTR法が186、CAS番号が75-09-2、といった内容が記載されています。このCAS番号を確認したところ、ジクロロメタンであることが後から確認できました。しかしこのようなSDSがあったとしても、事業所では活用のしようがありません。ジクロロメタンだということが分からなければ、おそらく必要な措置



を講じることもできないでしょう。有機溶剤だということも認識のしようがありません。しかし現場にはまだまだこのようなものが出回っているようです。

以上に関する私見ですが、まず①労働安全衛生法に基づく化学物質関連の省令は、複雑怪奇すぎるので有機則、特化則、鉛則、粉じん則、石綿則を統合・再構築してはどうかと思います。それと、②Pocket Guide to Chemical Hazards の日本版を厚生労働省（若しくは、委託を受けた労働安全衛生総合研究所）として発行していただき、現場で化学物質管理に携わる産業保健スタッフに役立ててもらいたいと思います。③事業場が、化学物質管理に専門家を参画させた場合は、作業環境管理とばく露管理（作業管理）のウェイトを事業者が自由に選択できるよう緩和してはどうか。そして将来的には、それも労働条件となることが望ましいのではないかと考えます。そして、④SDSを広く公開するような法整備が必要ではないかということです。現在、メーカーがSDSをホームページで公開している例は少なく、ユーザーから請求手続きが必要なケースが多い。例えば、化学品のラベルにQRコードなどを印刷させ、ネット経由で閲覧できるようにするなどしてはいかがでしょうか。また、その内容に関し、監視する公的機関（又は、業界団体の機関）も必要ではないかと思います。

以上、ご清聴ありがとうございました。

三柴 ありがとうございます。今回行政官・元行政官向けの社会調査を実施しましたが、その反応をみるといろいろな人がいるというのが実感です。大久保副所長は化学物質管理に対してこだわりをもって取り組んでこられたということで、今回ご報告をいただいた次第です。本プロジェクトの会合には多様な分野の専門家が参加されていますので、何かご質問やコメントがあればよろしくお願いします。

北岡 SDSの交付について質問させていただきたいのですが、先ほどのお話では、実態としてSDSは半分ほどしか交付されていないということで、私自身も衝撃を受けました。現在安衛法で法制化されているにもかかわらず、なぜ製造元の会社が譲渡先の会社にきちんと引き渡していないのか・・・その点大久保さんから見てどのような理由があるとお考えでしょうか。

大久保 様々な理由があると思いますが、メーカー側が成分などを第三者に知られたくないというケースもあるのではないかと思います。当然、そういう会社は化学物質のデータをできる限り表に出さないようにしているのではないかと思います。

北岡 安衛法第57条の2には罰則はついていましたでしょうか。安衛法上、罰則がついていない規定という理解でよろしかったでしょうか。

大久保 すみません、今すぐには確認が難しいです。

北岡 実際のところ送検事例もほとんど見受けられないということでしょうか。手元に便覧があるのですが・・・。

大久保 我々監督署が伺うのは、SDSの交付を受ける側ですので、その点は少々言い方が悪いですが、

あまり興味はないということでしょう。

三柴 罰則はないようですね。先ほどのご報告にもありましたように、企業機密にかかわるので、罰則をつけるのが難しいのかもしれませんが。

北岡 よく分かりました。ありがとうございました。

森 一点ご教示いただきたいのですが、さきほどOJTの話がありました。監督官の方は、たとえば研修所のようなところで、「〇年目研修」といったような定期的なステップアップのための研修を実施するのでしょうか。

大久保 埼玉県朝霞市に労働大学校という施設があり、採用後1カ月くらいでそこに3カ月間ほど入り、その後秋以降に2カ月間ほど入り、合計約5カ月間ほど研修を受けることになります。その後は中堅研修ほか時々に応じて研修を受けます。ただ、研修でカバーする分野は非常に広いものですから、特定の分野の専門性を高めるための研修はありません。おそらく厚労省もそういう特化した専門性を持った人材を必要としていないようです。言い方は悪いですが、広く浅い知識のある人材を最前線に配置したいという感じではないかと思います。

三柴 この点関係者との議論では、イギリスであればHSEがそもそも専門性を持った人材を任用して年俸制で処遇します。日本でいえば、特別規則それぞれについてインスペクターを任用します。たとえば、産業保健職であれば年収700万円くらいといった感じです。スコットランドはずれの油性を担当する担当官になると、地域手当がついて1200～1300万円、といった金額で任用します。それぞれが専門性を持っているという前提なので、事業者側としてもいいアドバイスを受けられるのでありがたいという一面もあるほどです。そういう専門性が管理に担保されている仕組みになっているわけです。日本の場合は大久保副所長がご指摘されたような現実があるようです。

唐沢 大久保さん、ご報告ありがとうございました。私は現役を離れて20数年になりますが、現在の現場の状況を興味深く拝聴させていただきました。私はかつて、現在の化学物質対策課に相当する部署の課長をつとめていた時期がありますが、ご指摘のようにNIOSHが発行している「Pocket Guide to Chemical Hazards」が用いられていますが、SDSの交付を義務付けている700数十の物質については行政側の参考資料があつてしかるべきかと思います。しかし三柴先生も身近でご覧になっておられますように、現職の方々は多忙を極めておられますので、行政が自らこれを作成するのは困難であろうと思います。ただ何らかの形でそういうものがあつた方がベターですから、何かの機会に責任者の方に要望しようと思います。

三柴 もうお一人ほどいかがでしょうか。

石崎 ご報告ありがとうございました。唐沢先生のご発言とも関わってくる話ですが、ポケットガイド

（Pocket Guide to Chemical Hazards）の日本語版のようなものが仮に出来たとした場合であっても、監督官は必ずしも専門性を有しているわけではなく、日本では文系の人材も多く含まれていると思われる。そういう現状で、日本語版ポケットガイドのようなものができれば、監督実務において活用される可能性が出てくるということでしょうか。もう一点ですが、ご報告の中で、化学物質管理に専門家を参加させた場合、作業環境管理と作業管理のウェイトを選択できるようにとのご提案があったと思いますが、そこで想定されている専門家の範囲と作業環境管理のウェイトという点で含意されている中身をもう少し具体的に教えただけであればと思います。

大久保 「Pocket Guide to Chemical Hazards」日本語版のお話ですが、当然行政官が有効活用できると思いますし、一般の労働衛生や産業保健の仕事に携わる方も有効活用できるのではないかとということで、広く公表されることが望ましいと思います。2点目のご質問について、私が想定しているのは労働衛生コンサルタントの衛生工学を専門分野に持つ方が、会社の顧問のような形で参画されるといった状況です。作業環境管理と作業管理の点についてですが、作業管理は曝露管理の話になりますので、たとえば局所排気装置やプッシュプル型換気装置を用いて作業場の平均濃度を下げる方法をとるのか、あるいは呼吸保護具やプロテクターを装着することによって曝露を下げる方法で作業を行うのか、専門家が参画することによってその辺りの選択をできるようにしてもいいのではないかとということです。当然のことながら、プロテクターを着けての作業は作業強度が大きくなりますので、労働条件の一部になると考えられます。そういう状況で働いてもいいと思っっている方と、逆に清潔な環境でプロテクターなしで働きたいという方と両方出てくると思います。その辺りは労働条件の一部と捉えて雇用契約を締結すればいいのではないかと考えているという意味です。

石崎 ありがとうございます。

三柴 化学物質管理を担う専門家として誰が相応しいかというお話がありましたが、ちょうど今開催されている検討会で以下のような資料が出ています。行政としては産業医、衛生管理者、小規模事業場であれば安全衛生推進者、作業主任者、特定の危険な作業に注意を払う人たちです。そして、資格という切り口で見ると、労働衛生コンサルタント、作業環境測定士、そして今後行政が育てたいと思っっているオキュペイショナル・ハイジニスト（インダストリアル・ハイジニスト）、といったものが候補になります。しかし、たとえば産業医は10万人の登録者がいながら実働しているのが3万人、そしてそのほとんどが嘱託で、作業環境や職場の現状を把握できないことが多く、健康診断+事後措置で精一杯というのが医師会の調査結果からうかがわれます。また化学物質に強い人も少ないです。衛生管理者についても化学物質に強い人の割合は少ないです。資格としての労働衛生コンサルタントについてみると、最近行政が化学物質を得意分野として標榜するコンサルタントの数を調査したところ、全国でわずか25人という結果でした。作業環境測定士は試験が易しく、化学物質管理の専門性を持った人がどれくらいいるかという、これもまた不安な状況です。安全衛生推進者は小規模な事業場で、特にハードルもないままなれてしまうので、化学物質に詳しい人もいないと思われます。作業主任者なら役に立つのではないかと考える人もいますが、てんでバラバラで割合的に化学物質に詳しい人は少ないでしょう。そういう現状です。



## 化学物質管理における人材に関する現状と課題

### <労働安全衛生法に基づく事業場内における管理体制>

	主な役割	配置基準・主な要件
産業医 (医師)	<ul style="list-style-type: none"> <li>健康診断の実施及びその結果に基づく措置</li> <li>長時間労働者に対する面接指導・ストレスチェックの実施</li> <li>作業環境管理・作業管理に係る医学的事項</li> <li>その他健康管理に関する事項 等</li> </ul>	(配置基準) 労働者数50人以上の事業場 (要件) 医師であって <ul style="list-style-type: none"> <li>日本医師会等の行う産業医研修修了者 ※5年ごとの更新制(産業医学生涯研修20単位以上を修了した者は更新可)</li> <li>産業医科大学卒業者で所定の課程・実習修了者</li> <li>労働衛生コンサルタント試験(保健衛生)合格者 等</li> </ul>
衛生管理者	<ul style="list-style-type: none"> <li>労働者の危険又は健康障害の防止措置</li> <li>労働者の安全衛生教育の実施</li> <li>健康診断の実施</li> <li>労働災害の原因の調査・再発防止 等</li> </ul>	(配置基準) 労働者数50人以上の事業場 ※一定の工業的業種は衛生工学又は第1種衛生管理者 ※30人以上を一定の有害業務に従事させる労働者数500人を超える事業場は1人は衛生工学衛生管理者 (要件) ・第一種・第二種:10年以上(高卒は3年以上、大卒は1年以上)の労働衛生実務経験+免許試験合格 ・衛生工学:労働衛生コンサルタント試験合格者、第一種衛生管理者免許試験合格者等、作業環境測定士資格所持者+衛生工学衛生管理者講習修了
安全衛生推進者(衛生推進者)	<ul style="list-style-type: none"> <li>労働者の危険又は健康障害の防止措置</li> <li>労働者の安全衛生教育の実施</li> <li>健康診断の実施</li> <li>労働災害の原因の調査・再発防止 等</li> </ul>	(配置基準) 労働者数10人~49人の事業場 (要件) ・大卒+1年の安全衛生実務経験 ・高卒+3年の安全衛生実務経験 ・5年以上の実務経験 等
作業主任者	<ul style="list-style-type: none"> <li>作業方法の決定・労働者の指揮</li> <li>排気装置等の点検</li> <li>保護具の使用状況の監視 等</li> </ul>	(配置基準) 特定化学物質、有機溶剤、鉛、四アルキル鉛を取り扱う作業 (要件) ・作業主任者技能講習修了者

## 化学物質管理における人材に関する現状と課題

### <労働安全衛生法に基づく外部の専門家>

	主な役割	主な要件
労働衛生コンサルタント(労働衛生工学)	<ul style="list-style-type: none"> <li>事業場の衛生についての診断・指導</li> </ul>	<ul style="list-style-type: none"> <li>大卒理系+5年の労働衛生実務経験+試験合格</li> <li>高卒理系+10年の労働衛生実務経験+試験合格 等</li> </ul>
作業環境測定士	<ul style="list-style-type: none"> <li>作業環境測定の実施</li> </ul>	<ul style="list-style-type: none"> <li>大卒理系+1年の労働衛生実務経験+試験合格+登録講習修了</li> <li>高卒理系+3年の労働衛生実務経験+試験合格+登録講習修了</li> <li>8年の労働衛生実務経験+試験合格+登録講習修了 等</li> </ul>

### <その他の外部専門家>

	主な役割	主な要件
オキュベিশョナル・ハイジニスト (日本作業環境測定協会)	<ul style="list-style-type: none"> <li>化学物質等に関し、①事業場における化学物質等の総合管理、②危険有害性(ハザード)評価、③ばく露評価、④リスク評価、⑤リスク削減、⑥既存のリスクによる健康被害等被害発生の調査、⑦残留リスク管理、⑧健康管理、⑨リスクコミュニケーション、⑩緊急リスクへの対応、⑪環境改善に関する工学的技術の指導・助言</li> <li>物理的因子についての適切な管理の指導・助言</li> <li>生物的因子についての指導・助言</li> <li>人間工学的因子についての指導・助言 など</li> </ul>	<ul style="list-style-type: none"> <li>第1種作業環境測定士or労働衛生コンサルタントor衛生工学衛生管理者or第1種衛生管理者or産業医資格+5年の労働衛生実務経験+93時間の講習+評価試験合格</li> <li>※資格は5年ごとの更新制(更新基準は、過去5年間のハイジニストとしての活動実績、技術研修受講、学術論文掲載、講習の講師等の実績から総合的に評価し、合格者のみ更新)</li> </ul>

※1 化学物質管理の専門性を有する労働衛生コンサルタントの数: 25人 (注) コンサルタント会の会員で専門の公表に同意している者の人数

※2 オキュベিশョナル・ハイジニストの資格保有者数: 52人 (注) 日本作業環境測定協会が公表している認定オキュベিশョナル・ハイジニストの人数



三柴 ハッキリ言って、惨憺たる状況です。そういう言わば基盤のない状況に高度な資格を設けたとしても、ブランドになり得るかと言えば、非常に厳しいであろうと思います。私としては、リスクアセスメントを幅広く定義して、原則として厳しく定めたうえで、免責を求めるのであれば専門家を活用してそのお墨付きを受けるといったような逆転の発想がよろしいのではないかと思います。つまり、危ないところに専門家を配置するのではなく、危なくないことを証明させるために専門家を活用するという方針を伝え、とりあえず特別規則の免除を受けるために専門家を活用すべきという枠組みを、中間とりまとめに入れていただきました。ともかく専門家を活用するための起爆剤が必要であると考えています。現状はなかなか深刻な状況であると言えるのではないかと思います。

では、他にご意見ご質問等ないようでしたら、大久保副所長のご報告はここまでにさせていただきます。ありがとうございます。続いて、原委員の方からご報告をお願いします。

原 よろしく申し上げます。私の担当は安衛法第20条・第21条（以下両条文を総称して「対象条文」とする）、危害防止基準の中でもっとも基本的な条文です。今回提出させていただいた私の分担報告書は、横断的課題と絡む部分を前回の報告書に追記した以外は基本的に前回のものと重複しています。2月にご参加されて私の報告をご清聴いただいた先生方には、ほぼ同じ内容をお話することになるかと思われませんが、新規ご参加の先生方もいらっしゃるのので、私がどのような方向で執筆させていただくのかにつき、あらためてご清聴いただければと思います。（※以下「分担報告書の抜粋（原）」（以下「原資料1」とする）に沿って報告）

対象条文は、物と場所に関する危害防止基準の確立を目指す規定ですが、三柴先生が再三ご指摘の通り、本プロジェクトはこれまでに公刊された実務書・学術書が試みてこなかったところの、現場に即したリアルかつ斬新な体系書を目指しています。そのような観点から、これまでの書籍が対象条文に関して試みなかったことは何かといえば、以下のように整理できます。学術書は対象条文の趣旨・内容を説明し判例を挙げ、関係政省令を紹介して終わりです。他方、実務書は図説などを活用しながら紐付き政省令である安衛則が何を要求しているのかを現場に即して分かり易く書いています。そのような状況で、私が対象条文に関して本プロジェクトで試みるべきは、安衛法本法と紐付き政省令をワンセットで有機的につなげながら、法全体が現場で何を求めているのかを検討するという作業です。対象条文の紐付き政省令は、安衛則第二編に定められた第101条から第575条の16までに至る膨大な数の条文です。これらからうかがわれる危害防止基準の共通項を挙げると、原資料1の1頁左段から右段にかけての枠内のように整理できます。

- |   |
|---|
| <ol style="list-style-type: none"><li>①機械等のうち労働者に危害を及ぼすおそれのある部位・箇所につき、囲い、覆い、運転停止などの手法によって安全化する。</li><li>②機械等の点検、検査、整備などを義務づけ、同時に使用限度の超過を禁止する。</li><li>③物による接触の危険を防ぐために労働者の身体に保護具などを装着させる。</li><li>④立入禁止などの措置によって、危険な機械またはその部位・箇所、危険な場所などに労働者を不用意に接近させない。</li><li>⑤合図などによって労働者に危険に対する注意・回避を喚起し、安全かつ合理的な行動を促進する。</li><li>⑥作業主任者など責任者を選任・配置することによって、指揮命令系統を整備し明確化する。</li></ol> |
|---|

労働災害は、特に機械安全や建設安全において特に当てはまることですが、危険源が労働者の身体に

接触することによって引き起こされるものです。そうすると必然的に、安全衛生や労働災害の予防は両者の接触を何らかの方法で可能な限り回避することが基本かつ重要事項になります。すなわち、危険源の発生前にこれを探知して阻止し（上記②）、その発出の出端を挫くとともに（上記①）、発出した危険に対処すべく労働者の身体を保護具等で守る（上記③）、という手法です。また、そもそも労働者の接近を防ぐとともに（上記④）、現場の労働者らの意思疎通によって危険源やそれがもたらす被害について注意を喚起し、それとの接触や接触がもたらす被害を回避させるという仕組みになっています（上記⑤⑥）。平成・令和のハイテク大国日本の危害防止基準はさぞかし高度で最新鋭の技術を用いていると想像するかもしれませんが、対象条文が現場に求める危害防止基準は、現場の実態や常識感覚に基づき、労働者の目線に立って、通常求められるシンプルな措置に重点を置いているといえます。

この辺りの特徴は沿革とも符合しています。ご承知のように安全衛生法制は戦前の工場法時代から戦後にかけて連続性がみられ、対象条文はその特徴が特に顕著です。上記①～⑥と同趣旨ないし類似の規定は、工場法およびその政省令の中にすでに見受けられますが、これらは安全衛生の基本、すなわち現場の労働者の目線を重視する規定であるがゆえに、技術の進歩や社会経済状況の変遷に左右されることなく一世紀近くにわたって安全衛生の基礎的なルールであったということです。そのような特徴を浮き彫りにしたいと思います。同時にもう一つの共通項的な特徴として、産業の発展と安全衛生のバランスを挙げられると考えます。すなわち、ある機械が危険であったとしても、当該機械の全面使用禁止あるいは製造禁止を求めるのではなく、その使用を認めつつ危険な部分のみが労働者に接しないよう、囲い、覆い、立入禁止、保護具等々といった形で危害を防ぎ、もって産業の発展と安全衛生とのバランスをとろうとする姿勢が、対象条文の行間からうかがわれる点についても明らかにしたいと思います。

今回提出させていただいた分担報告書では、原資料1・2頁左段の「2. 対象条文および関係政省令の文言からうかがわれる予防志向ほか安衛法制の基本的姿勢」という項目を追記しています。私は横断的検討課題として「危険のおそれ」という文言を用いた条文の趣旨・内容を調査する仕事を引き受けておりますが、もう一つの資料（労働安全衛生規則における「危険」・「おそれ」、以下「原資料2」とする）をご覧ください。未整理の段階で申し訳ありませんが、「危険」と「おそれ」という語句を用いている条文が多数ありまして、安衛則だけで「危険」が606回、「おそれ」が310回用いられています。「おそれ」という語句は安衛法本法にも40カ所ほどあり、その他の政省令も挙げるとキリがないのですが、差当り安衛則を中心に検討させていただきます。「危険」と「おそれ」がワンセットで用いられている箇所にも数種類のパターンがあり、まず「危険」を（が）及ぼす、生ずる「おそれ」のある「とき」、同じく「もの」、「部分」、「場所」、「ところ」、「箇所」といったように、場合、モノ、場所、箇所の4種類に分け、危険が具体化した後では労働災害の防止は遅いですから、「おそれ」という表現からも明らかなように潜在的な可能性がある段階で事業者は何らかの対処を義務付ける内容になっていて、まさに予防志向が顕著に表れています。同時に、危険のおそれが「ない」という表現の規定もあり、これらは原則として事業者は何らかの措置を義務付けたうえで、「おそれ」が「ない」場合に例外的に適用除外するという類の規定もあります。原資料2掲載の表において、ところどころ「※20」ないし「※21」と表記しているのは、藤森先生が本プロジェクトにおける検討対象としてピックアップして下さった条文という意味です。このように、横断的課題と逐条解説について、ここに挙げた「おそれ」という文言を用いる条文から検討を始めるという形で、両者を並行して進めていきたいと考えております。

原資料1に戻りまして、判例については、逐条解説と横断的課題の双方で取り上げるべき判例が民事・

刑事双方で多数あります。刑事裁判については一応リストを作って書き出してみました。前回の北岡先生のご報告で触れられた罪刑法定主義の問題と関連して、「おそれ」という抽象的な文言がこの原則に抵触しないか、あらためて再検討する必要が出てきたものと思われます。安衛法令関係の裁判例は、民事であれ刑事であれ、多くの場合死者あるいは負傷者が出てから、本人や遺族が民事賠償を求める、あるいは検察官が起訴するという形で始まっています。「〇〇のおそれ」という予防志向的な政省令が規定されながら、実際に適用されるのは予防が功を奏さずに死者・負傷者などの損害が生じた後に適用される場合がほとんどなわけですね。このことからすると、実は対象条文は、単独では予防効果が意外と期待できないわけで、別途安衛法上の他の規定や制度と連携しなければ、対象条文が目指す予防効果が実効性を持ちません。単独では危害防止基準として十分ではないという、少々皮肉めいた特徴も浮き彫りにすべきと考えています。今後の調査や執筆の過程で、機械や建設などの用語や器具に関して、行政実務やコンサルタント、あるいは安衛研の先生方にいろいろと質問をさせていただくと思われしますので、何卒ご指導のほどお願いいたします。

三柴 ありがとうございます、対象条文は危害防止基準を象徴する条文ですね。これに関する解説の方向性についてご報告をいただきました。危害防止基準を代表する条文であるからこそ、予防志向と運用の実際との乖離や矛盾がみえて悩ましいというお話があったかと思えます。先生方からご質問・ご意見ありましたらお願いいたします。あるいは、逆に原さんの方から教えてほしい点などありますか。

原 はい、今後個別的な質問としてある条文に規定されている機械器具等について、MLでご質問させていただければと思いますの、よろしく申し上げます。

三柴 原さんが条文のメッセージをまとめていったところ、結局3ステップアプローチのようなものが浮き上がってきたようです。藤森先生がライオンのたとえ話で説明して下さったお話ですが、まず1stステップは本質的安全措置を講じる、つまり機械であれば安全に設計されたものを使用するなどといったことです。2ndステップは本質的安全だけでは安全を担保できない場合に、保護具を装着する、危ない機械に近づいたら自動的に停止させる仕組みを設ける等といったように、補助的な安全工学的な手法で対応するものです。3rdステップは、それでもなお残留リスクがある場合には、人への教育や行動の制御など、人間への働きかけで安全を図るものです。そのような3ステップを対象条文の解釈から浮き彫りにしてくれたと思います。

このほか、法令を政省令レベルまで掘り下げていって、気づいた点はありますか。

原 挙げるとすれば、調査と計画でしょうか。特に作業場所です。事業場や工場の外で伐木作業等を行なう際に、地面に危険が潜んでいないか調査を行ったうえで、調査結果に基づいて作業計画を策定し、これに従って作業しなければならない。つまり、広い意味でのリスクアセスメントということで、平成20年代の改正によってリスクアセスメント制度が創設される以前から、事業場で自然を相手にするような就労場所では事業者が義務づけられていたということがいえると思います。

三柴 安全衛生のメインの目的は労災の防止ですが、私なりの表現すれば、「業務リスクの防止」ないし



「業務リスク対策」まで触手を広げる法制度であるといえます。自然災害であっても職域に関わってくる限りは対応が求められるし、交通労災防止も図っていくものです。単に労働の現場のみで対処すればいいというものではなく、労働の現場で起きる可能性のある災害に対応しようとするれば、必然的に幅広い視点を持たなければなりません。環境対策まで広げなければならない場合もあり得ます。また、機械や化学物質のリスクに対処しようとするのであれば、上流の方にまで遡っていく必要があります。そういった点も補足していることが、対象条文の解釈からうかがうことができます。

では、最後に淀川委員から経過報告をお願いします。

淀川 よろしくをお願いします。私の担当は安衛法第33条および第34条についてです。ご承知のようにこれらの条文は、事業者ではなくそれ以外の者に対する規制を定めた条文です。たとえばリース業者、あるいはアパートや雑居ビルを貸している人に対する規制です。お配りした資料「労働安全衛生法第33条及び第34条の逐条解説」（以下「淀川資料」とする）の「I はじめに」にも書きましたが、三柴先生の先行研究の報告書も指定しているとおり、このような規制対象の多様性を持つ条文は日本の安衛法の特徴であり、私の担当する条文はこれを象徴した条文であると思われまます。また、同2段落目に記載した通り、畠中先生の著書では、これらの条文は「場所」または「物」の管理権原に着目した規制として整理されています。

では、条文の内容をみていきますと、第33条は「機械等貸与者等の講ずべき措置等」との見出しです。この条文は、大きく分けて3つの規制を定めています。どのような機械に対する規制かといえば、移動式クレーンや車両系建設機械、不整地運搬車、高所作業車などについて、一定の要件を設けたうえで規制が定められています。まず一つ目の規制として、これらの機械を貸与する場合に貸す側すなわちリース業者の義務を定めています。どのような義務かといえば、大きく分けて二つあり、事前の点検と補修等です。二つ目の規制として、書面の交付義務です。第33条第2項は、貸与を受けた人の義務で、操作者（オペレーター）が付いている場合の措置、すなわち必要な資格を有する者であることを確認する、作業内容・指揮系統・連絡合図の方法等を通知する、などが定められています。この点は裁判例でも問題になっていて、実務的にも重要な問題のようです。同条第3項は操作者つまりオペレーターに対する義務が定められています。第2項の規定内容を遵守するよう安衛則第668条に定められています。

これらの条文が設けられた趣旨は、淀川資料2頁記載の通りですが、リースを受けた側は所有権限がなく、あくまでそれはリース業者にあり、借りた方は補修や改造をすることができないため、労災防止措置を十分に講じることができません。このため、同条第1項でリース業者に規制を施したという趣旨です。第2項の趣旨は、運転手に対する規制を行い労災防止を図るというものです。

「3 沿革」（淀川資料2頁）ですが、まず工場法や旧労基法には第33条の基になるような規定はなかったと思われまます。安衛法制定前の労働基準法研究会の報告書をみると、この時代はリース業者がかなり目立っていることが現状の確認として指摘され、また賃貸業者が機械を貸し出す場合の条件を大別すると、機械のみ貸す場合と機械とオペレーターをとともども貸す場合とがあるとのこと。続いて淀川資料2～3頁に記載したとおり、「機械のみ貸す場合は、安全衛生上、構造要件保持義務を負担するのは形式的にはその機械を借りて作業をすすめる側にあるわけであるが、当該機械について補修改造することはもとより、日常の点検さえできる体制にあるか否かは疑問である。」「また、機械を操作する人間をつけて貸す場合、その人間に対する安全衛生を確保する責任は誰にあるのか・・・疑問が残る」というこ



とで、これに対する手当をすべきだということが指摘されていまして。この他、衆参両議院の社会労働委員会でも同様の指摘がなされていまして。同委員会では安衛法が単独の法律として制定された理由が述べられていまして、事業者以外の人に対する規制を設けるということは、事業者（使用者）に対する規制を主とした労基法とは毛色が違うため、単独法にすべきであるとされていまして。参院の社会労働委員会でもリース業者に関する言及があり、これらに対する規制を行うべきである旨指摘され、労基法とは別途独立した法律を定めるべきであると言われていまして。

「4 適用の実際」を確認したところ、最新のデータでは令和元年9月1日から令和2年8月31日にかけて、第33条違反が1件ありました。また、三柴先生からいただきました厚労科研のアンケートには、「機械貸与契約（いわゆるオペ付きリース）により、多くの建築工事現場で移動式クレーン作業等が行われているところであるが、本条による措置が不十分であるため、災害・事故が発生している状況もみられる。措置が不十分な例としては、機械貸与を受ける者がリース業者に対して移動式クレーン作業計画を示すなどにより、法定事項を通知していないことなどである。」という監督官の回答がありました。

「5 関係判例」を調べたところ、2件ほどヒットしましたが、今回はそのうち1件を簡単に紹介させていただきます。刑事事件で、先ほど紹介した第33条第2項の「機械等の貸与を受けた者」が労働災害を防止するため必要な措置を講じなかったものとされた例です（福岡高判昭52・8・3）。

三柴 少々よろしいでしょうか。ひとつ前の話で、適用の実際に関する監督官の情報についてですが、機械の貸与を受ける側、つまり借りる方の側が作業計画を示さなかったことがまずいとされた例が挙げられていますが、これは機械にオペレーターが付いてくるケースを前提にしているのですか。あるいは機械だけを貸与するケースでしょうか。

淀川 読んだときは、オペ付で貸与するケースかと思っていたのですが・・・

三柴 はっきり書いてない以上、わからないと思いますが、おそらくオペレーターも一緒に付いてくるケースでしょう。すみません、ご報告続けてください。

淀川 ありがとうございます。先ほどの判例の話に戻りますが、宅地造成・不動産売買を営む被告会社が重機業者から運転手付でブルドーザーの提供を受け、カントリークラブ造成工事の整地作業をしていました。その際に労働災害を防止するために必要な措置を講じなかったということで、会社と社長が安衛法違反の罪に問われたという事案です。第1審は安衛則第667条第1号・第2号違反の罪が成立するとして、両者をそれぞれ罰金3万円に処しました。これに対し被告会社らが控訴しました。この事件の争点は、①被告会社が第33条第2項にいう「機械等の貸与を受けた者」に該当するか否か、②機械操作者の法定資格又は技能を特に確認しなかったことが可罰的違法性を有するか否か・・・可罰的違法性とは刑事裁判を経て処罰に値する程度の違法性があるか否かという問題です。そして、③被告人らが労働災害防止のため必要な連絡、合図等の方法を通知すべきであったか否か、です。これらの争点に判断が加えられ、結論として控訴が棄却されました。①については、形式的に貸与を受けたかどうかという点だけで判断せずに、被告会社が労働者に対して作業計画を策定していた、賃金の内容を決定していた、作業内容を指示していた、などの点が実質的に考慮され、被告人が労災防止をすべき立場であったと認定して第3

3条第2項の該当性を肯定しています。②の点ですが、この事件では機械操作者は法定資格を保有していたため、確認をしなくても結果は変わらなかっただろうと思いがちです。しかし、やはり裁判所としては確認しなかったこと自体が問題であったとして、たとえ操作者が法定資格を保有していたとしても、違法性があると判断しています。③の連絡や合図の方法については、裁判所は具体的に旗を立てる、見張り人を置く、などといったことができたにもかかわらず、何らの措置も講じていなかった被告会社は罪に問われるべきであると判断しています。

以上は第33条の問題で、このほか第34条は雑居ビル、工場アパートなどを事業者に貸与している人に対する規制を定めたものです。どのような措置を講ずべきか淀川資料5頁の図に示した通りですが、共用の避難用出入口や警報設備の設置、貸与建築物の有効維持、給水排水設備や清掃等が求められています。同条の趣旨は、雑居ビルや工場アパートが増加していたところ、そのような建築物の一部を借りた者に対して労働災害の防止を義務付けても、実行を期し得ない場合が少なくないということで、貸与する側に規制を課すといったところでした。沿革を調べたところ、工場法や旧労基法だけでなく、労働基準法研究会の報告書にも目立った記載がなかったので、また違った視点で調査していかなければならないと考えています。適用の実際についても、対象条文に違反した事案は見当たらず、関係判例も出てきませんでした。なので、もしご存知の方がいらしたらぜひご教示いただければ幸いです。

今後の課題としては、第33条・第34条ともに適用の実際を引き続き調査し、なおかつ図や写真が乏しいところなのでこれも補充すべきと考えます。また、第34条の沿革に関する調査も引続き行う必要があるものと考えます。

以上、報告を終わります。

三柴 ありがとうございます。コメントやご質問ございましたらよろしく申し上げます。あるいは、逆に淀川さんから尋ねたいことはありますか。

淀川 第34条の建築物を貸与した側に対する規制の沿革や適用の実際など、資料を調査してもなかなか出てこなかったもので、適用例などご存知でしたらご教示いただきたいと思っております。

三柴 建物については、確かに旧労基法時代の安衛則の中には見当たらないです。以前私が整理した旧安衛則のブリーフを共有しましたが、これを検索しても見当たりません。しかし、本質的な安全確保という趣旨で特定の機械器具等については、貸与者を対象とした規制は旧安衛則時代からありました。つまり、貸与者を規制する発想は以前からあったという点については言及してもよろしいかと思っております。昭和47年の現行安衛法が規制の対象を広げたということです。では、肝心の建物の貸与者について何らかの事件があったかについては、調べてもなかなか出てこないわけですね。この点については、行政官向けに実施した社会調査の集計を待っていただいて、そこに何らかの結果が出ていればそれを拾ってください。また、藤森先生のご協力をいただいて、関係者の方にアンケート調査では調べ切れなかった条文に関する実例を調査する予定ですので、その際に拾ってみたいと思っております。

では、以上をもちまして本日の会合は終了とさせていただきます。本日も充実した議論をありがとうございました。

三柴 本日もご参集いただきありがとうございます。本日は労働基準監督官の森山氏に報告者としておいでいただいているので、一人ずつお名前など簡潔に自己紹介いただければと思います。

（参加者の自己紹介）

ありがとうございました。それでは、お送りした会議開催要項に沿って進めたいと思います。まず、イギリスで行った社会調査の結果について報告します。すでに現物をお届けしましたが、ひと言でいうと、イギリスの安全衛生文化の高さがデータとして見える化されたものと感じています。たとえば、そもそも回答者にトップマネジメント層が多く、また、経営者が安全衛生を重視していると回答した企業では、かなりの割合で安全衛生担当役員を選任していることがわかりました。そして、安全衛生の専門家のステータスが高いことがかなり明確になりました。専門家であれば相応にリスペクトされ、処遇も高いということが読み取れます。イギリスでは産業医制度が法定されていません。というより、法定されている国の方が少なく、フランス、ドイツ、オランダなど数えるほどしかありません。では、イギリスで産業医制度を法令で定める必要があるかという問いに対しては、ほとんどが“No”でした。これはなぜか考えてみると、GPが勤労者医療という枠組みで産業医のような役割を果たしていることが挙げられます。そして、健康問題や安全衛生を扱う専門家全体にいえることですが、医師ではなくてもステータスが高いので、医師免許で箔付けする必要はないのではないかという感じがします。あくまで推論ですが。企業内で安衛法をよく知る人の割合は日本とさほど変わりはありません。「よく知っている」が2割ほどで、「かなり知っている・相応に知っている」が4割ほど、合計6割程度というデータでした。その分専門家を尊重し、そのステータスを高く認め、これに頼っていることがうかがわれ、この辺りはイギリスらしい特徴を読みとることができます。他方、日英で共通する点としては、安全衛生を重視していると回答した経営者にその理由を確認したところ、日本と同様労災が生じると良心が痛むという人間的な理由を挙げる人が多数でした。それと、イギリスの安全衛生法典（HSWA）が労災防止効果を持った理由を尋ねたところ、やはり安全衛生管理体制の構築と回答した人が多かったです。安全衛生のためのマネジメントを適切に行うための体制を組み立てることが意味を持ったのではないかということです。それと同じくらいに、労災防止のために具体的な何をすべきかを示した危害防止基準の整備が大きいです。要するにマニュアルの整備、体制の整備、マネジメントの整備といった多方向から労災が減ったという回答が多くみられました。この点は日英共通です。その他、経営者・管理者が負う法的責任の重さも重要であると、多くの人が回答しています。また、イギリスで今後検討すべき政策上の重要課題としては、クラウドワークなどフリーランスの安全衛生、メンタルヘルスなどが高い割合を示しています。なお、調査票作成の段階で調査業者のコンサルティングを受け、その際に質問票の内容を修正したりすることもあります。イギリスでは60歳以上になるとほとんどの人が働かないので、高齢労働者の安全衛生問題の質問は意味がないとの指摘を受けたため、その質問は削除したという経緯がありました。このような結果から、日本の安衛法は国際的には成績優秀で、まだまだ出来ることはあるということがうかがわれました。

もう一点、行政官・行政官OBに向けた調査の結果が概ねまとまってきました。本省から協力依頼の通知を出していただいたので、調査結果は相当数集めることができました。同じ労働行政であっても、真面目に回答してくれたところもあれば、「回答不可」との返答を返してきたところ、そもそも返事すらくれないところもあり、本省から通知があったとしても対応は様々で、労働行政はやはり組織的にも個人的にも個性がモノをいうといった感じを受けました。この調査では安衛法の条文の現場での使われ方をメ

インに調査したのですが、やはり調査結果が多く出た条文とそうでない条文に分かれます。割と割っていたよりもまんべんなく結果を得られたという感じはするものの、やはり集中的に多く関係情報がとれた条文とそうでない条文がありました。ざっと見て、危害防止基準に関わる第20条、安全衛生体制に関わる第29条以下、特に元方規制のような事業者以外の人たちに安全衛生管理体制を構築させる規定などの現場の運用状況に関する情報が多くみられました。このほか、作業環境測定法の運用状況を回答してきた人もいました。こうしてみるといわば「宝の山」であり、特に法学系・行政学系の先生方は、ここから拾った情報を【適用の実際】に埋め込んでください。これによって相当にリアリズム溢れる本ができるのではないかと思います。

ここであらためて強調したいのは、本プロジェクトを通じて完成を目指す本の特徴は、現場のリアルがみえる体系書です。タイトルをつけるとすれば「事例で読み解く労働安全衛生法」、そういうイメージのものを作りたいわけです。そうかといって、単に図解を乗せて内容的にアカデミックでないものにしたわけではなく、現場的にも有用で学術的にも高水準なエンサイクロペディアをつくることを目指しています。これによって安衛法を盛り立てていきたいので、現場情報も豊富でなければなりません。なので、判例、実例、運用実態などを徹底して重視してください。以上の点をあらためて強調したいと思います。そのための情報として、今回の調査結果は非常に大きな価値を持つと考えています。ご承知のように労働監督行政については監督年報が毎年公刊されていますが、これは違反の摘発件数等が数字で並んでいるに過ぎないものです。今回の調査結果をフル活用してください。なお、藤森先生に行政官およびそのOBに話を通していただき、調査とインタビューを受けて下さる方がいらっしゃるとか聞いています。今回のアンケート調査結果の中で情報が足りない条文について藤森先生のご協力をいただいて調査を深めていきたいと考えております。

それでは、本日の特別報告として森山監督官からお話しいただきたいと思います。お願いしたテーマは、安全衛生に関する監督指導の実態と法改正の提案です。

森山 埼玉局の森山と申します。大学の物理学科を出て、第48期採用の労働基準監督官を務めております。ちょうど民主党政権最後の年で定員数が少なかったのですが、私は「B採用」すなわち理工系の採用ですので、もともとは法律方面の知識がなかったのですが、任官後に井上浩先生の著書などで勉強しました。今回実務家としてお招きされましたが、上の世代の方とはやり方が異なるかも知れず、また最近では技官の人数も少ないため少々不安も感じますが、色々な分野の先生方からご指導いただければと思い、今回報告させていただき次第でございます。

配布させていただいた資料（※「安全衛生に関する監督指導の実際と法改正の提案」、以下「森山資料」とする）の2頁に目次を付しましたが、まず「1 監督指導における危害防止基準の適用」を簡潔に説明させていただき、その後は「2 監督実務における事例（化学物質を中心に）」というお話で進めていきたいと思います。3および4は、私の思い付きの範囲なので、時間に余裕があれば若干お話ししたいと思います。

では「1 監督指導における危害防止基準の適用」（森山資料3頁）から始めます。労働安全衛生法の危害防止基準（第20条から第24条まで）は、即ち危険源の分類であるということで、法のレベルで危険源ごとに分類し、これらの規定に基づく具体的な危害防止基準（安衛則、クレーン則、有機則等の省令）も、当該危険源の分類に基づいて整理されています。従って、危害防止基準の適用にあたっては、まず安



衛法の危険源分類に基づく危険源同定を行い、同定された各危険源に対して法令を適用するという方法をとっています。こういう手法は意識的というよりも、なんとなく無意識的に行っているという感じです。さらに、事業場において危険源をより多く見つけ、危害防止基準を的確に、体系的に適用することが重要です。森山資料4頁は臨検の風景ですが、このような場合にどれだけ多くの危険源を発見できるかが重要になってきます。森山資料5頁の「種々の安全衛生法令」に掲載したとおり、非常に多くの安全衛生法令がありますが、我々がよく参照するのが安衛法で、場合によってはリスクアセスメント指針も参照します。こだわりのある方はJ I Sを使います。安衛法には多くの政省令が紐付いていて、条文数は千を超えていると言われています。我々がいつも使用しているのが安衛法便覧（森山資料6頁）で、政省令を参照するのにこれ以上の資料はないというのが共通認識です。安衛法第20条から第24条までが狭義の危害防止基準であり、危険源の分類がなされています（森山資料7頁）。ただし第24条については関係政省令がなく、強いて挙げれば腰痛予防対策指針がこれに含まれるのかと思います。厚労省が出してるリスクアセスメント指針にも同じような分類が示されています（森山資料8頁）。森山資料9頁に載せたのは労働安全衛生規則の目次ですが、ここでもほぼ同じような分類で規定が設けられていますので、我々としても便覧を参照する際に便利な構造になっています。

森山資料10頁の「一般法と特別法」ですが、たとえば安衛則第二編・第一章・第三節の二に食品加工用機械に関する規定が設けられていますが、食品加工用機械には第一節の一般基準の規定も適用されるので、一カ所だけをみるのではなくいろいろな箇所を参照しながら適用される法令を探すこととなります。そのような背景知識をもってみると、臨検時に森山資料11頁掲載のような多くの危険源が同定されるようになります。たとえば空気調和設備は「機械」という危険源ですが、同時に粉じんや二酸化炭素という危険源への対処として設置されているものです。こうして危険源を分類することによって危険源が見えてきます。そして、安衛則の目次（森山資料12頁）から各危険源の規制を探して適用していきます。実際には、“えっ、こんなところにあるのか!?”といった感じで見つけにくく、目次からは分からないものもあり、事業場で臨検を実施した際には文字検索のツールがないものですから、安衛則の目次から探索せざるを得ないというのが実態です。不安を感じるようであれば、いったん持ち帰って労基署の方で是正勧告書や指導文書を作成して交付するというやり方も、最近は多くなっていると思います。

三柴 すみません、今の持ち帰りに関わる話をもう一度お願いできますか。

森山 以前は事業場を臨検した際にはその場で指導文書を交付することが多かったと思います。指導文書とは是正勧告書や指導票のことです。使用停止命令については、現在でも現場で交付しようとする場合が多いです。特に化学物質規制の条文が多くなっていて、是正勧告書を2枚も3枚も書いているとそれだけで日が暮れてしまいますので、最近は持ち帰ってPCで作成し、後日臨検先企業を呼び出して交付することが多いです。また、化学物質を主眼としつつ、ほかに賃金台帳などの書類をチェックすることが増えていて、そうなるとそのような資料は工場ではなく本社にある場合がしばしばですので、それらも一緒に確認する意味も込めて、企業の方に来ていただいてそこで是正勧告書等を交付するケースが最近増えているのではないかと思います。

ただ、危険源だけを見ているといろいろ弊害もあり、森山資料13頁に「危険源指向」の注意点を挙げました。すなわち、「モノだけでなく、作業行動を含む全ての危険源を何らかの危険源に分類する」こと

が必要です。危険源という言葉からは、作業行動よりも機械などのモノに着目してしまいがちですが、作業行動も危険源として分類しうることを意識する必要があります。また、「危険源の分類が固定化しすぎると、見落としが発生しうるので、時々違う分類を試すべきである」。安衛法の分類は固定されているので監督指導においては安衛法に従わざるを得ないとしても、JISなどには異なった危険源の分類があり、これらも適宜参照すべきかと思えます。あるいは、「危険源だけに着目せず、事故の型を意識しながら危険源を探すことも新たな視点を与える」といったことも、建設業では多いかと思えます。そして、危険源の分類は「要素還元主義的な手法であることを反省し」、たとえば化学物質の混合・反応などについては「ホーリズム的な見方の必要性も認識する必要」があります。

「危害防止基準の体系的な適用」(森山資料14頁～)は3ステップメソッドの話になりますが、各危険源に関して最初に検討すべきはやはり「本質的安全設計」で、次は「工学的対策」、「管理的対策」、最後に「個人用保護具の使用」になります。あくまで原則ではありますが、以上が3ステップメソッドと呼ばれるものです。森山資料16頁に一例としてレタスを洗うコンベヤーを挙げました。

### 3ステップメソッドの例 (機械)

例 レタスを洗うコンベヤー (ベルトが金網製で、開口部が1cm×1.5cmのもの)

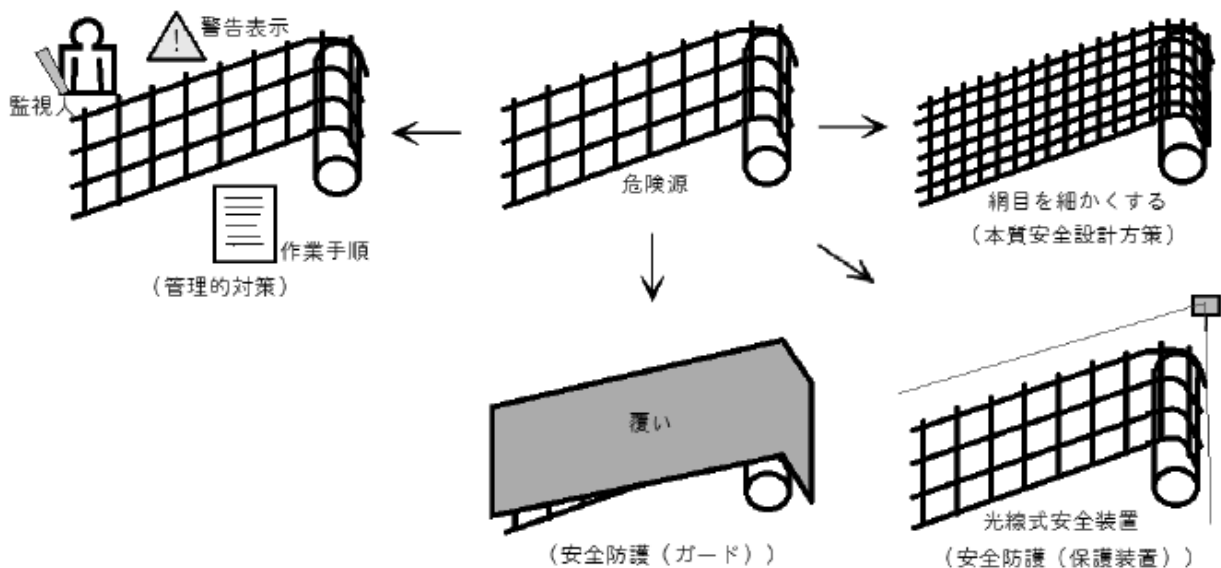

p. 16

一番いいのは右上の図のように網目を細かくすることですが、そのほか危険部位を修正するといった方法がとられます。

森山資料18頁は、法令中の3ステップメソッドの例で、移動式ではない普通のクレーンに関するものです。クレーンの構造規格やクレーン則もこのように上手く分類できると思えます。この表は機械包括安全指針のリスクアセスメントの枠組みにそって書いていまして、表の左側が製造者が行うリスク低

減措置で、右側がユーザーが行うリスク低減措置です。機械包括安全指針においては両者は別々に規定されているので、このような区分けになります。

有機則をみても（森山資料19頁）、概ね工学的対策、管理的対策、個人用保護具という流れで規定されています。測定や健康診断はまた別の枠組みかと思えます。包括安全設計はどうなっているかと言えば、安衛則の「第三編 衛生基準」の冒頭である第576条に包括的な規定があります。

安衛則は危険源の分類ごとに章立てされていますが、個々の危険源に関する規定について細かくみると3ステップメソッドの順序に従っているようです。なお、ジャッキ式つり上げ機械の作業に関する規定が安衛則第194条の6に定められていますが、第1号で「作業を行う区域内には、関係労働者以外の労働者の立入りを禁止すること」とされ、まったく関係のない人の立ち入りを禁止するという意味では本質安全設計方策ということになりますが、作業に多少関係のある人を対象とするのであれば管理的対策と解することもでき、両者を含む趣旨であると思われまます。

リスク低減措置に関する注意点として（森山資料21頁）、危険源に対して工学的対策を講じるために設備を導入した場合は、その設備もまた新しい危険源になるため、繰り返しリスクアセスメントを継続する必要があります。同様に、保護具もまた新しい危険源になり得ます。最近では、マスクによる皮膚疾患などが例として挙げられます。

森山資料22頁に私の監督手法を記載しましたが、重要なポイントは一番下にあるとおり、「事業場で作成する社内の安全衛生対策の基礎資料は、概ね危険源毎に分類して作成し、併せて危険源の一覧表を作成するよう指導する」ということです。資料の整理方法としてはそれがベストかと思えます。監督実務における事例として森山資料23頁の「2.1 典型的な化学物質使用作業場の事例」を紹介させていただきます。自動車再塗装業ですが、車のボディを見栄えよく塗装し直す仕事なので、埃のない塗装室が設けられていることが多いです。塗装室にはほとんどの場合プッシュ・プル型換気装置が設置されているのですが、それが無い場合が悩ましいところです。局所排気装置やプッシュプル型換気装置は非常に高額な設備なので、設置していない事業者も見受けられます。森山資料24頁は違反の様子を描いたものです。違反条項をみると、まず有機則第5条違反、つまりエアスプレーガン塗装に対して発散抑制の設備という工学的対策を実施していません。また、シンナーの缶をの蓋を開けたまま作業する、塗料の調合についても相応の対策をしないまま行っている点など、第5条違反として整理できると思えます。ただ、スプレーガンについては是正方法としてはプッシュプル等の方法で是正を指導することになりますが、シンナー缶の扱いは設備違反として指導票の交付によって蓋を閉めさせる、あるいは塗料混合機は通気の良い場所で使用させるなどの是正になると思えます。また、マスクを着用していなくても特に違反にならないという状況があります。よくみられるのが「サージカルマスク」です。3Mで活性炭フィルタ付マスクが販売されていますが、それはあくまで防塵マスクに過ぎないものであって、防毒マスクは使われていない場合があります。作業環境測定で第3管理区分となった場合は防毒マスクを着用しないと違反になります。

難しい問題として、ロール紙等への接着剤塗布業務が挙げられます（森山資料25頁）。紙であったりビニールであったりしますが、こういう巻物状の材料に有機溶剤を塗布する作業は設計が難しいのですが、実際は図のように換気装置のダクトが単に設置されているに過ぎないことが多いです。反対側にはこのように、接着剤用シンナーが蓋のない容器に入ったまま、蒸気を発散しています。違反条項としては、換気装置を局排と認定しないで有機則第5条違反とするのか、あるいは局排と認定したうえで風速

がなく形が悪いということで第14条第1項・第16条第1項とするか悩ましいところです。是正の方向性としては、プッシュプル型換気装置の設置が考えられ、図の右側に是正方法の図を示しました。あるいは、全体を部屋にして局排を設置するという方法もあります。

森山資料26頁は金属製品の塗装業の図です。ここには非常に高額な局所排気装置が設置されていますが、徐々に風速が弱まっていき、発散源において制御風速が出ていない状態です。この場合も有機則第14条・第16条違反、つまり制御風速が出ていない、あるいは発散源から離れているということになります。是正方法としては風速を上げるよりも、作業場所を近づける、あるいは局所排気装置を点検して設置し直す等の方法になると思います。局排には法定性能がないので、第5条違反が成立するのか否かについては、いつも悩むところです。

森山資料27頁は工場の新築工事における床面加工業務です。工場を新築する際には、コンクリートをそのままにするのではなく、床面をきれいに塗装するなどして加工します。建設業者の方で化学物質に詳しい人はさほど多くなく、作業主任者の資格を持っていても有機則を遵守していない場合もあります。図はスチレン関係の塗料を塗布する作業なので、有機溶剤として有機則の適用を受けるので、第5条違反になります。ただし、発散面が広いので全体換気装置を設けて有機則第10条を適用するべきですが、全体換気装置自体がない場合が多いので、結果的に第5条を適用し違反を勧告することになります。

三柴 よろしいでしょうか。特別規則に詳しくない方も参加されているので、有機則第5条と第10条の内容を簡潔に説明していただけないでしょうか。

**【参考】有機溶剤中毒予防規則（昭和47年労働省令第36号）**

第5条 事業者は、屋内作業場等において、第一種有機溶剤等又は第二種有機溶剤等に係る有機溶剤業務（第一条第一項第六号ヲに掲げる業務を除く。以下この条及び第十三条の二第一項において同じ。）に労働者を従事させるときは、当該有機溶剤業務を行う作業場所に、有機溶剤の蒸気の発散源を密閉する設備、局所排気装置又はプッシュプル型換気装置を設けなければならない。

第10条 事業者は、屋内作業場等の壁、床又は天井について行う有機溶剤業務に労働者を従事させる場合において、有機溶剤の蒸気の発散面が広いため第五条又は第六条第二項の規定による設備の設置が困難であり、かつ、全体換気装置を設けたときは、有機溶剤の蒸気の発散源を密閉する設備、局所排気装置及びプッシュプル型換気装置を設けないことができる。

森山 第5条は第二種有機溶剤、すなわちスチレンなどを使用する際には発散源を密閉する設備を設け、それが不可能なら局所排気装置かプッシュプル型換気装置を設ける義務を規定しています。要するに鼻や口に有機溶剤の蒸気が入らないような特殊な設備を設けなければ違反になります。第10条は、床面のような広い発散源から有機溶剤の蒸気が発散し、口や鼻に入るのを完全に防ぐ設備を設けるのが難しい場合に、通常の換気扇と同様の手段をとればよいとする規定です。森山資料27頁にいう強制換気であり、窓を開けてそこにダクト、排風機のようなものを持ってきて空気の流れを作ります。



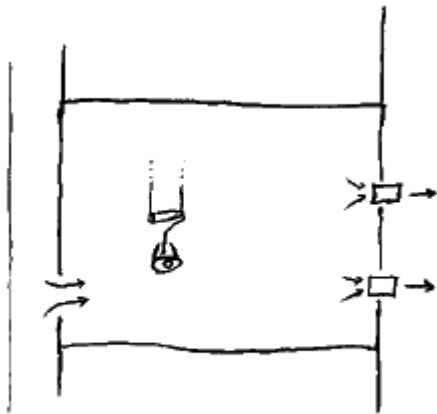

同頁のこの図は上から見た平面図ですが、左側から新鮮な空気が流れ込んで、右側の2か所から流れ出ていくような全体換気装置を設置するという事です。たとえば言うなら、カレーを作る際に“カレーのにおいがしないようにせよ”とするのが第5条で、カレーのにおいはするものの、有害性がない程度に薄めよとするのが第10条といったところでしょうか。27頁のような事案では、第10条にいう全体換気をすべきかと思いますが、それすら設置していないので第5条という原則規定の適用も可能です。同時にこの事案では、労基法第64条の3もあり得ます。すなわち、女性は同条に規定する業務に従事させることはできないことになっています。

労働基準法

- 第64条の3 ① 使用者は、妊娠中の女性及び産後一年を経過しない女性（以下「妊産婦」という。）を、重量物を取り扱う業務、有害ガスを発散する場所における業務その他妊産婦の妊娠、出産、哺乳等に有害な業務に就かせてはならない。
- ② 前項の規定は、同項に規定する業務のうち女性の妊娠又は出産に係る機能に有害である業務につき、厚生労働省令で、妊産婦以外の女性に関して、準用することができる。
- ③ 前二項に規定する業務の範囲及びこれらの規定によりこれらの業務に就かせてはならない者の範囲は、厚生労働省令で定める。

それから、研究開発業務において接着剤などをつくっている研究施設などには、ドラフトチェンバーという設備があります（森山資料28頁）。ドラフトチェンバーは比較的設計が楽なので、自信をもって販売している会社が多いですが、実際に何年も使っているうちに窓を開けすぎて開口面が広いと風速も落ちてしまいます。そのような好ましくない運用が多いかと思えます。試験や研究業務の場合は作業主任者の選任が不要です。つまりわざわざ講習など受けなくても、設備を扱う研究者であれば適切な使用を期待できるからです。なので、実際現場では誰も何も知らなかったという事態もあり得ます。

次の頁に移りまして、監督業務の現場で感じた化学物質関係規定に関する問題について少々お話させていただきます。「(a) 有機溶剤業務への非該当性」、すなわち製造工程において材料として有機溶剤等を大量に使用していても、製品が有機溶剤等でなければ、有機溶剤業務に該当しないということです。有機則第1条第1項第6号には有機溶剤業務の分類が定められていますが、そのいずれにも該当しないのであれば、有機則は適用されません。「(b) 局所排気装置等の設計・性能測定」ですが、ガス、蒸気又は粉じんの発散防止抑制設備（局所排気装置、プッシュプル型換気装置、全体換気装置等）は事業

者に計画の届出義務があり、労基署長がこれを審査・指導（一部命令あり）することとされています。このうち、局所排気装置（ドラフトチェンバーを除く）及びプッシュプル型換気装置の設計は計画段階で大きな問題があることが多いです。例えば、局排の外付け式フードの形状が、ロール紙等への接着剤塗布業務の事例（森山資料25頁）のように不適切なものであることが多く、この場合、ぶつ切りダクトの開口部で制御風速が出るように設計されているものさえあります。つまり、肝心の作業場所では制御風速が出ないわけです。また、無届けで設置されることも多く、監督指導においてフード形状・制御風速違反を指摘し、設計からすべてやり直しを行い、事業者には莫大な費用が必要が生じることも多いです。

「(c) 有機則の設備の特例許可と科学的検討」ですが、有機則の発散防止抑制設備としては、蒸気の発散源の密閉設備、局排、プッシュプル型換気装置（以下「局排等」という）を原則としているが、有機則第13条（蒸気が発散面が広すぎる場合に局排等に代えて全体換気装置を設置する特例許可）、有機則第13条の3（局排等以外の発散防止抑制措置を行う特例許可）があります。しかし、事例の蓄積がないこと、労基署職員の専門性が乏しいこと、測定機器・シミュレーション装置がないこと、特例許可制度が知られていないこと等により、2.1(b)のようにフード等の設計が非常に難しい場合にも局排等による指導を行う状況となっています。局排等の設置が難しい場合もあるのですが、差当たり第5条に依拠して勧告することがあります。どのようなものであれば許可できるのかについて現場で適切なイメージがないので、この点事業者にかなりの負担を課しているのかもしれない。

「(d) 作業環境測定」に移ります。相当に作業環境が悪そうでも、作業環境測定結果をみるとなぜだか第一管理区分で済んでいる場合があります。たとえば夏場を避けて作業華僑測定を実施すると、夏場の劣悪な作業環境を測定することができないので、結果が異なります。また、作業主任者と衛生管理者が違反を認識できていない場合もあり、そういう制度が形骸化している会社もあるかと思います（(e) 作業主任者及び衛生管理者制度の形骸化）。

化学物質の製造について規制しているものがありますが、「(f) 副生成物」は「製造」とは言えないので、条文上「製造してはならない」あるいは「製造する場合は・・・しなければならない」とされている場合には、たとえば塩素などの副生成物として生じるだけの状態ではこれに該当せず違反にならないこともあります。イオン性物質を混ぜた結果有害物質になってしまう、あるいは未規制物質を水に溶かした結果規制対象物質に変化する場合には、特化則などの法令が適用されるのか、現場で議論になることもあります（(g) イオン性物質の水溶液（電離））。たとえば、シアン化金(I)カリウムは規制していないが、例えば、シアン化金(I)カリウム  $K[Au(CN)_2]$  を水溶液とした場合に、水溶液中では一部が電離してシアン化カリウム  $KCN$  水溶液の混合物と同じものになるのではないかという問題です（※シアン化カリウムは特化則で規制しているがシアン化金カリウムは安衛法で特に規制していない）。

少々化学物質の問題から離れまして、少々“あれっ？”と思うようなエピソードをご紹介します。森山資料35頁の「(a)事業場の単位」が問題となります。すなわち、同じ場所（同じ建物内）に複数設置している事業所をそれぞれ独立の事業場として事業場の規模（労働者数）を決め、労働者代表を選出していることがあります。異業種、つまり工場内の食堂や診療所であれば独立が可能とされていますが、決算の都合などで社会福祉法人などを同業種のもの、つまりケアマネや特養などに分離してしまっている例があります。これにより、安全管理者等の未選任、安全委員会等の未設置、労使協定の無効化などの問題が生じています。つまり、合計すれば50人以上になるのですが、ケアマネや特養などに分けてしまうとそれぞれ10人や30人になってしまうので、結局このような問題が出てくるわけです。また、労災隠しの

問題になるのですが、「(b) 計画の届出及び労働者死傷病報告の管轄」は事業場の所在地を管轄する労基署長に提出することとされているのですが、建設工事の場合は実際には建設現場の所在地を管轄する労基署長に提出するよう指導しており、法令と実務にずれが生じています。大規模な現場は事業場として認められますが、2日程度で終わる簡単な工事で労務管理もその場では行われていない場合には、現場で提出してもらっています。調査に赴くのは現場を管轄する労基署なので、そこに提出しないと調査にできないという理由からです。

さらに、「(c) 危険な機械の流通」という問題もあります。プレス機械などの生産機械には、耐用年数が長いものも多く、80年間使用しているものもあり、50年などは珍しくありません。このような古く安全防護のない機械（必ずしも労基法・安衛法施行前の製造とは限らない）が中古品販売業者により流通し続けており手指の切断・挫滅等の災害が多発しています。安全防護に関する知識のない事業者がこれを購入し、製造・流通業者が実際には責任を負わない例が多く心苦しいところです。なお安衛法には製造・流通業者への立入検査規定というのはないので、これがどのように使えるのかと思います。たとえばHARD・OFFに安全装置のない木工機械や丸鋸が、オークションサイトに危険そうなプレス機械が出品・販売されていることもあります。また、倒産した会社から引き取った仲介業者が別な会社に売るといったこともあります。そのような場合は、その機械の製造元すらわからないこともしばしばです。

「(d) 注文者等の義務」。工事現場での話ですが、2階建て一般家屋の外壁塗装工事において、鋼管足場が設置されていたが、引込み線（100V）が足場に噛んでしまい、1人で塗装工事を行っていた一人親方が感電死したという事件がありました。しかし、一人親方であるため法違反は認められませんでした。一人親方は「労働者」ではないため、自己責任という面があります。しかし、一人親方は個人事業主であるが、足場の設置は注文者≒元方事業者が統括しており一人親方の努力でどれだけ改善が図れるのかという問題があります。

森山資料38頁に移りまして、「3 労働安全衛生法・命令に関する疑義」の問題です。「(a)法第5章の適用範囲」ですが、安衛法第5章「機械等並びに危険物及び有害物に関する規制」の通達によると、労働基準法の適用範囲より拡大され、一定の機械等又は有害物質の製造等を行う者は何人もこの法律の規制を受けることとなりました。安衛法は第1条で労働災害の防止を目的としているので、たとえば現場で就労している人たちが全員個人事業主であった場合などには法が適用されないものと解釈する人もいるので、コンメンタールなどでそういった点が明確にされると助かります。

三柴 今の点について、もう一度趣旨をご説明いただけますか。

森山 法第5章に違反して法定の安全装置が設置されていない、検定を受けていない機械、たとえばボイラーを家で使用するために適当に作って設置したような場合に、それが原因で爆発事故が生じたとしても山奥のような場所であれば労働者に危害を及ぼす可能性はないのではないかと。そういう場合には安衛法違反にならないのではないかとこの考えを持っている人がいます。

三柴 要するに危険源が問題なのであって、当事者が「労働者」に該当しない場合であっても、安衛法は適用されるということを明確にしてほしいということですね。

森山 ご指摘の通りです。あるいは、第1条で労働災害の防止をうたっているのに、それと矛盾するのではないかということもあります。

三柴 そういう狭い解釈をしてしまう人がいるということですね。そのような考えでは労災は防げないから、コンメンタールでそうではないのだということをも明記するべきだということですね。

森山 その通りです。次に、「(b)法第57条の「主として一般消費者の生活の用に供される製品」（消費生活用製品）」という文言があり、SDS交付義務等の適用除外対象となっています。たとえばトルエンは通知対象物ですが、販売するにしても「主として一般消費者の生活の用に供される製品」であればSDSの通知を要しないという趣旨の条文です。この条文の解釈について経産省のWebサイトを調査したところ、製造事業者又は輸入事業者が業務用として製造又は輸入している商品であっても、その製品の仕様や販路等から判断して一般消費者がホームセンター等で容易に購入可能で一般家庭で使用できるような製品は、消費生活用製品と解される旨書かれていました。これは消費生活用製品安全法の解釈と思われるのですが、最近ではホームセンターへ行けば概ね何でも買うことができ、またインターネット上の通販サイトでも各種塗料を買ってしまうので、SDSの違反に対してどの程度是正勧告できるのか、相当に迷うのではないかと思います。もし刑事裁判になった場合に法令を適用できるのかどうか不安に駆られることもあります。また、「(c)法第88条等の「設置」と「移転」という問題があります。機械等設置届のルールに従って設置届、あるいは移転する際には移転届を出さなければいけない規定になっています。ただ、「設置」と「移転」の違いは微妙で、新品を購入するのであれば「設置」ということになりませんが、事業譲渡した場合には当初からその機械がその場所にあるので「設置」といつていいのかが問題となります。労基法のコンメンタールで寄宿舎の解釈として、既に存在する建物を借り上げる際には「設置」という扱いになるという説明がありました。しかし、条文上「設置工事の14日前までに」設置届を出さなければならない旨の規定になっている場合に、「工事」とは何を指すのかが曖昧になってきます。また、非適用事業であったものが労働者の雇用によって適用事業になる場合、仕様変更・改造により規制対象の機械等となる場合・・・たとえば2tのクレーンを改造して5tに変更するなどといった場合です。また、他人の所有であった工場を借り上げてその中に規制対象の機械等が既にある場合、親会社が所有するものを、構内下請が使用する場合、他人のものを一時的に借りる場合、などといったケースです。これらが「設置」に該当するのか、そして「工事の開始の日の三十日前」をどう解釈するかを明確にする必要があると思います。また、各階に別々の事業場が入居している建物のエレベーターの設置義務が誰にあるのかというのはメーカーにとって「永遠の謎」と言われています。「設置」と「移転」との区別も非常に難しいところがあります。たとえば、東京のA社が大阪のB社に機械を譲渡した場合に移転なのか設置なのか、判断に困るところです。

「(d) 法第88条の機械等変更届の「主要構造部分」、これは事前審査制の対象となっていますが、法第88条第1項の機械等変更届の対象となるのは、機械等の「主要構造部分」の変更とされているが、これが何を意味するのか明確になっていない状態になっています。少なくとも現場レベルではハッキリしていません。たとえば足場の壁つなぎは足場の崩壊を防ぐので「主要構造部分」と言えそうですが、局所排気装置のフードの形状変更や動力プレスの安全装置の変更は、いずれも安全防護に関する極めて重要な変更ですが、主要構造部分といえるのか不明です。



最近ではコロナ禍のせいもあって、電話やメールでやり取りをすることもありますが、立入検査妨害あるいは監督官や技官の調査に対して虚偽の陳述をする等の行為は、安衛法上処罰の対象となります（「(e) 法第120条第4号の立入検査妨害罪」）。以前、障害者を使用する工場でジクロロメタンを使っていて、事業者も使用するのにはマズいという認識があったようで、事実と反してジクロロメタンを使用していないという回答をしました。そのような事案で、どうすれば虚偽陳述として法違反が成立するのか判断に迷うところがありました。安衛法と労基法ではかなり規定内容が異なっているのですが、果たしてメールや電話でも成立するのか、あるいは事業場を臨検したときの陳述でないとダメだと解釈する人もいます。その点明確にすべきかと思えます。

途中少々割愛させていただいて、森山資料47頁「4(b) 危険源分類による規制と安全靴等」に移ります。これは長年私の中で疑問が膨れ上がった問題ですが、労働安全衛生法第20条～第24条の構造から、危険源毎の規制形式をとっている労働安全衛生規則の中で、第558条第1項（安全靴等の使用）は特異な規定になっています。いわく「事業者は、作業中の労働者に、通路等の構造又は当該作業の状態に応じて、安全靴その他の適当な履物を定め、当該履物を使用させなければならない。」この規定は、危険源を「通路等の構造又は作業の状態」などとしており、「通路等の構造」は法第23条との関連をうかがわせるものですが、「作業の状態」は第24条の作業行動に関係するものとも、法第21条第1項の「作業方法」とも関係するものとも取れます。『安衛法便覧』ではこの根拠条文を法第21条第1項としていますが、これに限定するのは無理があるような気がします。この問題の本質は、安衛則第558条第1項が、危険源を曖昧として、個人用保護具だけを規定しようとしたものであるからではないかということであり、そうすると、危険源毎に規制を試みている危害防止基準（法第20～24条）にうまく適合しないものと思えます。

「4(c) 社長の特別教育受講」という問題があります。安衛則上、労働者につり上げ荷重が1トン未満の移動式クレーンを運転させるときは、特別教育を実施しなければならないことになっています。しかし、労働者でない者（事業経営主や一人親方など）が運転する場合は特別教育に関する規定は問題となりません。しかし当然、移動式クレーンは自分だけでなく他人をも傷つける機械であるから、このような規定方法は不十分ではないかと思われまます。また、混在作業で言えば、安衛則第104条その他の「関係労働者」に別会社の労働者が含まれない場合はこれも含むような法改正も検討すべきだと思われまます。ちなみに安衛則第104条は、「機械の運転を開始する場合において・・・関係労働者に対し合図を行なわせなければならない」とする規定ですが、「関係労働者」に別会社の労働者が含まれない場合はこれも含むような法改正も検討すべきだと思えます。

最後に、「4(d) マスクによる危険の防止」についてです。マスクは「器具」ですから、マスクの規格違反つまり防毒マスクの規格に違反するようなマスクを使用すると、安衛法便覧によれば労働安全衛生法第20条違反になるとされています。また、政省令では安衛則第27条違反になります。これは、器具を規制するのが第20条だからということであるが、第20条は「危険」しか防止していません。しかし、マスクの規格違反によってもたらされるのは危険というよりも健康障害であるので、これについては第22条違反、あるいは規格違反の機械等の違反について独立した条項を設けるような規定方法が必要ではないかと思えます。ただ、「危険と健康障害」は、「安全と衛生」に対応するもので、その解釈自体がコンメンタールに書かれていませんので、その辺りも問題になるのではないかと思えます。鉱山保安法の特例（※安衛法第115条第1項「この法律（第二章の規定を除く。）は、鉱山保安法第二条第二項及び

第四項の規定による鉱山における保安については、適用しない。) にいうところの「保安」は安衛法上の「安全」とほぼイコールということになるので、安衛法の安全に関する規定は鉱山には適用されないということでもよろしいかと思いますが、その前提として「安全」とは何かが明確でなければなりません。このため、危険と健康障害の定義をはっきりさせる必要があるのではないかと考えます。

以上、ご清聴ありがとうございました。

三柴 ありがとうございました。非常に明快なお話だったと思います。法学系のメンバーは安全衛生になじみのある人が少ないので、技術的なお話の中には伝わりにくい部分もあったかもしれませんが、非常に明快に語っていただけたと思います。安衛法は基本的には労災防止を図るものですから、リスク管理を重視して目的志向で解釈することが必要になります。そのための安全行動への働きかけの装置である安衛法を活かしてゆくための論点をピックアップしていただけたように思います。法律である以上、罪刑法定主義の要請もあり、様々な概念を定式化することも必要になります。しかし本来の趣旨は安全行動への働きかけなので、それゆえにあえて曖昧にしておく必要のある面もあります。そのような調整をどのように行っていくかが問題になっていることについて、現場と法制度の両眼的視点で語っていただいたように思います。

先生方からご意見・ご質問ありましたらお願いいたします。

北岡 ご報告ありがとうございました。大変勉強になりました。一点お伺いしたいのは、ご報告の中で「同定」、「要素還元主義的手法」、「ホーリズム」など興味深い用語が出てきました。これらは工学系や理系の方が用いられる言葉でしょうか。この点ご説明いただければと思います。もう一点、ご報告をお伺いして印象的だったのは、これまでの安全衛生における現場監督では、監督官もそうであったし、会社の安全衛生担当者もそういう側面があったと思いますが、職人的な監督手法をとっていたと思います。すなわち、長年にわたる個人個人の経験をふまえて災害のポイントを見つけ出し、改善につなげていこうという傾向が多分にあったものと思っていました。本日のご報告から職人的手法を離れて、もう少しロジカルにやっけていこうというスタンスがうかがわれました。この点監督手法の在り様についてのお考えをお聞かせいただければと思います。また、もう一つには単なる私の感想ですが、やはり昨今の日本の経済情勢の厳しさがある意味影響しているものと実感しました。丸鋸などの中古品で非常に不安全なものが売買されている、あるいは第88条のご説明の中で閉鎖された工場のクレーンを再使用するなどといった実情は、私自身認識がなく、これまでのわが国の安全衛生施策が想定してこなかった問題ではないかと思いました。

森山 まず「同定」ですが、これは「特定」ともいいます。危険源の同定はJISの用語で、リスクアセスメント指針では「特定」です。私は大学ではシステム科学を専攻していましたが、要素還元主義にこだわるのではなく、全体を見る視点も重要であると言われていました。化学物質の混合などは分かり易い例かもしれません。

北岡 図で示していただいて興味深いと思ったのは、最近では監視カメラが色々な場所に設置され、AIによって識別・認識することも容易になっています。その辺のお話と安全衛生とが重なってくる部分

があるのかと思って聴いていました。

森山 監視カメラで巡視が可能かどうかということでしょうか。

北岡 そういうことです。そして人ではなく、コンピューターが認識して判断することが可能かということなんです。

森山 そういう方法で網羅的に出来てしまうかもしれません。リスクアセスメントでは網羅性が重要なポイントになってきますので、安全管理がしっかりしていたとしても、酸欠だけはまったく分からない、あるいは全ての機械は安全であるものの有機溶剤がわからない、そういう場合はAIで予め危険性を明らかにしておけば人頼みでないシステムができるかもしれません。

北岡 ありがとうございます。

三柴 他にいかがでしょうか。

鎌田 ご報告ありがとうございました。2点ほど質問があります。まず、一人親方のように雇用に基づかない働き方をする人の安全衛生のお話の中で参考になったのは、安衛法では機械の設計、製造、輸入を行う者も労災防止の責任を課せられる仕組みになっています。第1条に「労働災害の防止のため」という目的が規定されているとおり、たとえば機械の設計・製造異状が原因で災害が生じた場合に、負傷した人が一人親方の人もいれば労働者の人もいるという状況があると思います。私はそのように、一人親方と労働者が同一の現場に混在している中で災害事故が生じ場合、すべて分け隔てなく労働災害として安衛法違反になると思っていたのですが、先ほどのご説明では、一人親方の場合には違反の問題にはならないという解釈になるのでしょうか。

森山 違反になる場合とならない場合とがあると思います。規格違反の古い安全带・・・高所作業で使う命綱ですが、法改正によって相応の設計のものでなければならぬとされているところ、不要になった規格違反の安全带を一人親方に譲った場合、譲渡制限に違反すると思います。そのような形で一人親方を保護することができる場合があります。流通規制の適用は限定的ゆえに、たとえば足場の上に一人親方がいるような場合には、これに対する流通規制関連の安衛法上の保護はないものと思います。

鎌田 その場合、労働災害の防止目的という文言が効いてくるのでしょうか。

森山 実際の規定自体が「事業者は・・・」となっている場合、一人親方に関する措置は特に定められていないことだと思います。

鎌田 なるほど。もともと安衛法は「労働者」を適用対象としています。ただ、聞いたところによると、一人親方であっても事故が発生した場合には違反の責任を問う場合があり得るということだったの

で・・・。

森山 実際にそのようなケースはあります。あまり実例はないかもしれませんが、ボイラーを一人親方に譲渡した場合は違反になると思います。ただ、機械であればどのような場合にも適用されるというわけではなく、機械の中のごく一部に過ぎません。たとえば丸鋸の安全装置などがそうです。食品加工用機械などはいかに危険なものであっても、製造流通については規制がありません。このような回答でよろしいでしょうか。

鎌田 非常に貴重な問題提起でありたいと思います。もう一点よろしいでしょうか。安衛法第88条の設置の際の計画届の規定の件です。事業譲渡で事業者が変わった場合であっても、機械は従前から使っていたものをそのまま変わらずに使用する際に、計画届の対象になるのか問題提起されていたと思いますが、同条の趣旨からすると、従前と同一の機械を使用する場合であっても事業者が変わった場合には、物理的な意味での設置ではありませんが、計画届の対象としての設置には該当するものと漠然と思っていたのですが・・・。

森山 実際そのような取り扱いになっています。労基署の安全衛生部署や労働局の健康安全課は目的志向で動いていまして、特定機械に関することについては検査証の問題もありますので、非常にしっかりできている方ではないかと思います。特定機械でない場合は、労基署が指導しないと何も始まらないという面があり、是正勧告や書類送検の段階までいくと、本当に処罰に至るのかという疑問が出てきます。特に、第88条は「当該仕事の開始の日の三十日前までに・・・」という文言になっているので、ここでいう「工事」とは何かという問題も出てきます。

鎌田 私も工事の開始時期が問題となる場合に、据え置きの場合にはどうするのかという疑問があると思いました。ご回答ありがとうございました。

三柴 私の方から少々コメントさせていただきますが、要は安全衛生は監督指導業務とはいえ、労災を防ぐことが目的です。だからリスクアセスメントを適切に行ってリスク管理を図ることの重要性を指摘されていたと思うのですが、そうするとAIで安全衛生の監督指導ができるのかという問題に至ってくると思います。AIでできることは、定量的に数値化できる世界です。難しいのは、質的な人間的ポエムの世界で、その区分が必要になってくるでしょう。実際、予防の仕事になると経験則を踏まえて勘を働かせないといけない領域をゼロにすることはできませんから、ご報告の際に図面で示された定式化を図りながら、人の手当も図らないといけません。方程式を組み立てるにしても変数というものがあり、事業者が負担しうるコストの問題もあるし、人的体制の問題もあり、コミュニケーションの質の問題もあり、そういった点を補足した上でどのような対策を指導すべきか、質的な判断が必要になってきます。そうすると、地方任用の技官制度をなくしてしまったのは痛手かもしれません。森山さんのような監督官が全国津々浦々活躍してくればいいのですが、監督官として法令の知識がありながら安全衛生技術も知っているという人はあまりいないと思います。

森山さんには明快で貴重な情報提供をいただきましてあらためて深く感謝いたします。それでは、い



ったん休憩とさせていただきます。

三柴 先ほどお伝えし忘れたのですが、森山監督官から問題提起があった一般消費者向けの化学物質に関するSDSの問題については、現在厚労省で開催されている検討会において、それも含めてSDSの交付対象とするよう、事業者にはハザードリスクの情報が渡るように通達を出す方向で進められています。この点についてはご心配無用と思われれます。ただ、このような問題提起をいただけたこと自体有益なことであると受け止めております。

森山 特に画材屋などが問題になりそうです。

三柴 なるほど、消費者へのアクセスという意味では便利になった分だけ、有害物質の曝露のリスクも増えているということですね。

それでは再開させていただきます。本日は、各分担研究者から研究経過報告をお願いすることになっていますが、最初に私の方からお伝えします。共有画面に映しているのは私の分担報告書の途中経過です。安衛法第29条以下の注文者や元方など事業者以外の者の安全衛生責任に関する規定に関して、どのような判例があるかをまとめた箇所について端的に概要を説明して途中経過報告に替えたいと思います。まず、河村産業所事件（鍋田農協倉庫倒壊事件）（名古屋高判昭47・2・28判時666号94頁）という古い事案をご紹介しますと、コンクリートの打設工事中に支保工が不安定で、なおかつ雨も降っていたために、建物が倒壊して屋根の上で打設工事に従事していた作業員らが墜落して死傷したというケースです。実際に現場作業の指揮をとっていたのは元方事業者の監督者でした。旧安衛則時代の事件ですが、当時は現行法と異なり元方規制が存在しませんでした。元方規制が創設されたのは昭和30年代になって労災防止団体系法ができたときであって、旧安衛則時代は使用者を対象とした労基法に紐付いた規制ですから、使用者のみを対象としていました。実際に責任を問われるべきは元方の管理者であるにもかかわらず、どんなに悲惨な災害事故が起きたとしてもこれを取り締まることができないのはおかしいだろうということで、使用者を名宛人とした規制を根拠に刑罰裁判となったわけです。判決は、安全衛生の目的に沿った広い解釈を示しました。型枠支保工の組み立てについて、「実質上、現場における作業上の指揮監督をし、かつ、現場におけるその安全措置をとるべき権能と義務を有していた」のは元方の管理者でした。その型枠支保工を利用して、「コンクリート打設作業等に従事したA産業の現場係員はもとより、A産業と直接雇傭関係のない鳶、土工、左官等各労働者に対する関係」でも、「現場における・・・作業上、総括的に、実質的な指揮監督をし、かつ、現場における安全措置を講ずべき権能と義務を有していた」。確かに条文上の名宛人は「使用者」となっていますが、同条にいう「使用者」の概念は、画一的に定めることはできないのであって、例えば、賃金支払い面では使用者との関係が重要かもしれませんが、同じ労基法や紐付き政省令であっても安全衛生の場面で賃金と同じような解釈をする必要はないとしました。そうでなければ、複雑多様な労働関係において、労働者の労働条件の保護と向上を図ることは困難となるからである、と。施工を担当する下請に労基法上の安全義務を尽くす能力がない以上、工事を総括する元請人がその義務を負担しなければ法の目的を達成することができない。したがって、安全衛生に関するかぎり解釈は広めにしてよいとのこと。以上を刑事裁判で明言したのが特筆すべき点かと思えます。

次は、労働判例百選にも掲載されている有名な判決ですからご存知の方もいるかと思いますが、大石塗装・鹿島建設事件（最一小判昭和55・12・18民集34巻7号888頁）です。直接安衛法の条規

に言及していませんが、元請らの社外工に対する安全配慮義務を肯定したケースです。大規模な製鉄会社が発注した工事をゼネンコンである鹿島が請負い、そのうち塗装工事の部分を大石塗装が請負いました。死亡したのは大石塗装に雇用された作業員でしたが、高所で作業していました。高所には鉄骨で足場が組み立てられ、養生網が設置されていたのですが、本人が面倒くさがって着用指示に反して安全ベルトを外し、なおかつ養生網の一部に穴をあけてそこから紐付きのバケツを上下させて塗料をくみ上げていました。被災者はその穴から墜落死したわけです。このような事案において、判決では元請である鹿島建設の安全配慮義務違反が認められました。判決で認定された安全配慮義務の内容としては、安全ベルト着用や養生網設置の指示など物的・人的に通りの基本的な安全対策を講じてはいましたが、安全パトロールすなわち巡視を怠っていたということです。巡視を適切に行っていたら、この状況を察知して対策を講じることができたはずで、この点は元請の鹿島も下請の大石塗装も怠っていた事実があるということでした。そして元請は社外工との関係でいうと、下請けの雇用する労働者であり、請負契約関係と雇用契約関係でつながっていることにより、安全配慮義務違反の責任を負うと判断されたケースです。判決は安衛法の条文に直接言及していませんが、安衛法第29条以下の趣旨を民事裁判で示したものといえます。

3件目は、これも労災に詳しい人は知っていると思いますが、尼崎港運・黒崎産業事件（神戸地尼崎支判昭54・2・16判時941号84頁）で、これは安衛法の条規に具体的に言及したケースです。元請が保有する船から下請の保有するトラックにスクラップを積み換える作業を行っていました。その際に、大きな磁石で金属スクラップを引き付け、トラックの真上で磁力をオフにして落下させて積み換える方法をとっていました。このため、トラックの上で作業に従事していた下請の労働者が、跳ね返った鉄片で眼球を損傷する怪我を負いました。彼は痛みのためトラックの荷台に移動して休もうとしたところ、よろめいて転落して負傷し、その結果7級の障害、つまり労働能力を56%喪失する障害を負ったわけです。今の説明のとおり、この事件では元請は事実上あまり関与していません。積み換えをする荷物を積んでいた船を保有していただけに過ぎません。事実上そのような関係でしかなかったわけで、規則違反を問責するのであれば、直接の雇用主であった下請こそ、保護具を装着させなかったということで安衛則538条違反、あるいは作業主任者の選任怠ったことなどを指摘されるどころです。しかし元請についても、実際には元方として作業の一部を担っていたがゆえに、作業の実情を認識・把握していたことからすると、判決は元請も法的責任を負うとしました。その際に安衛法第29条および第30条に言及していますが、特筆すべきは下請が負っている安全配慮義務を恒常的に元請も負うなどといった民事的な法解釈論を展開したのではなく、安衛法第29条および第30条が元方の責任を規定しているところ、これを直截民事裁判に適用できる旨述べた点です。安衛法の条文をそのまま民事裁判で適用したわけです。畠中先生らのご尽力で元方規制が安衛法に組み込まれた結果、このような判断を生んだと言えます。もともとは、旧災防団体系に盛り込まれた規定ではありますが、現行法に取り入れた結果、このような判決が生まれたということです。

最後の事案は発注者と元請が関与しています。元請から時計の針に化学物質を用いて印刷を行う作業を一括して請け負っていた下請業者がいたのですが、そこで就労していた作業員数名が、印刷の際に使用するノルマルヘキサンに曝露し多発性神経炎に罹患し、かなり重篤な被害を受けたというケースです（みくに工業事件・長野地諏訪支判平3・3・7労判588号64頁）。ノルマルヘキサンは有機則所定の第二種の有機溶剤です。これを元請が下請けに提供し、使用させていた状況下で生じた被害だった

ということで、元請の安全配慮義務違反が認められました。なぜ元請の責任が認められたかという点について、裁判所は以下のように述べています。まず、元請と直接の雇用先であるK製作所が元請・下請という請負関係にありました。ちなみに直接の雇用先である下請会社は潰れていまして、被災者としては責任を追究しようにもできない状況でした。なので、なおさら元請を問責しなければならなかったわけです。そして、元請が直接の雇用主である下請企業の従業員に作業手順を指示し、また、労働手段である機械器具や備品などを貸与していました。なお、家内労働法という法律がありますが、内職労働者に対して注文者が化学物質や労働器具を貸与していた場合、それに伴うリスクを管理する責任が定められています。それと同じような趣旨をこの判決は述べています。それと、直接の災害原因となったノルマルヘキサンを含むAベンゼン等を元請が支給していたという経緯があり、さらに下請はこれら化学物質やそれを用いた作業に関してまったく知識も経験もない一方、元請にはありました。裁判所はそのような評価をしています。ただし、注意すべきはこの事件は安衛法第29条をそのまま適用できるような前提条件ではありませんでした。元請は発注者から受注した仕事をそのまま下請に丸投げしていました。自ら仕事の一部を負担していたという事情はまったくありませんでした。したがって、法第29条をそのまま適用している条件を充たしていません。しかし、第29条以下が趣旨としているところの、リスク創設者ないしリスク管理が可能にある立場の者がリスク管理の責任を負うという趣旨を、この判決は踏まえていると解されます。また、この判決が言わんとしているのは、法第57条が定めているリスクコミュニケーション、つまり実施させる作業にどのようなリスクがあるのか、対応策はどうすればいいのかなどといった情報を提供する、SDSに関わるような規定の趣旨を民事裁判で示したものと理解することもできます。

以上の判例を紹介した趣旨は、やはりこれまでの社会調査の結果から、日本でもイギリスでも、安全衛生管理体制をしっかりと構築することによって災防効果が生まれていることが分かります。法制度上、狭義の労使関係のみを規律するのではなく、元方や注文者など事業者や使用者以外の者にまで責任を負わせ、彼らが場の管理や組織の管理をする仕組みを法の中に組み込んだことによって、かなりの災防効果が生じたことが、社会調査の結果からうかがわれます。今後も引続き、安衛法は業務上のリスクは何か、兼業フリーランスや現在であればCOVID-19など新たな職域のリスクが生じた場合、そのリスクがどういうものを特定して、それに対応するには誰に音頭を取らせるのがいいのか、などといったことを考えて、目的にあった形で法制度設計を行っていく必要があります。そういった示唆を汲み取るために、関連する判決を紹介させていただいた次第です。

私の報告は以上です。それでは次に、佐々木先生にご報告をお願いします。

佐々木 私 の 報 告 書 を 共 有 画 面 に 表 示 し て お り ま す が 、 昨 年 1 1 月 初 旬 に M L で 配 布 さ せ て い た だ い た も の を 後 日 加 筆 し て 三 柴 先 生 に 提 出 さ せ て い た だ い た も の で す 。 概 要 を お 話 し ま す と 、 私 の 担 当 条 文 は 安 衛 法 第 2 2 条 及 び 第 2 3 条 に な り ま す が 、 前 回 の 報 告 で は 特 別 衛 生 規 則 に 関 し て ま と め て い る 旨 説 明 さ せ て い た だ き ま し た 。 ま ず は そ の 辺 り か ら 始 め た い と 思 い ま す 。

ま ず 第 2 2 条 の 内 容 に つ い て 執 筆 し ま し た が 、 紐 付 き の 関 連 規 則 が 非 常 に 多 い 条 文 な の で 各 規 則 に つ い て 細 か い 点 は 割 愛 し ま す が 、 特 に 使 用 頻 度 や 関 連 度 の 高 い 条 文 に つ い て 先 生 に ま と め て い た だ い た 表 に 基 づ い て 執 筆 し て い ま す 。 そ の 上 で 有 機 則 な ど 特 に 重 要 な 規 則 ・ ・ ・ こ の 点 に つ い て は 特 別 衛 生 規 則 に 関 す る 横 断 的 課 題 を 担 当 さ れ て い る 藤 森 先 生 や 作 業 環 境 測 定 を 担 当 さ れ て い る 石 崎 先 生 と の 重 複 を 避 け



るよう意識していましたので、各規則の大まかな制定の経緯や改正の流れなどについて簡潔に書いています。第22条の「考察」・「結論」に必要な範囲で執筆しています。さらにその上で各規則の重要条文、たとえば先ほどの森山先生のご報告で触れられた有機則第5条などについて触れています。こうした作業を各規則について試みています。沿革の箇所では、以前に三柴先生からいただいた労基研の報告書があるので、旧労基法第42条以下の内容が安衛法に移行する際の経緯について、同報告書の内容も反映させる予定です。

前回の報告に加筆したのが、特に関係判例の箇所です。前回は規則に関係するものを主として取り上げていましたが、今回は振動や騒音のように、規則でカバーされていない問題に関する安配義務違反の判例を中心に執筆しています。規則のない問題については通達、たとえば「チェーンソー等使用に伴う振動予防について」等の通達を根拠に、通達の内容を具体的な義務内容とする形で安配義務違反を認める事案があります。特別衛生規則の条項が存在しない問題については、このような形で根拠づけがなされていることが明らかになっています。もう一点、珍しい事件かもしれませんが、行政訴訟において監督署の権限不行使の責任が争われたケースがあります。この場合、どのようにして権限不行使を認定するか、その要件を記載しました。稀有なケースなので、もう少々検討が必要かと思われます。以上が加筆部分ですが、「適用の実際」には三柴先生が冒頭に示していただいた調査結果を反映させて加筆を進めたいと思います。ここまでが第22条関連の進捗状況です。

次に第23条ですが、基本的には第22条と同じで、特に事務所則が重要になる条文です。なので、事務所則の制定の経緯やその後の改正の動向に触れています。第23条の関連判決としては、刑事事件として安衛則540条にいう「通路」の解釈が問題となった事件があります。複数の会社に関与した事案で、約9mの高さの作業場所に開口部があり、作業をしていた他社の労働者がそこから墜落して死亡した事件で、その管理責任の所在が争われました。判決は、安衛法第23条違反が問題となる「通路」というのは、自社が雇用している労働者にとっての通路であり、それ以外の人が行き通ることによって事故が起きた場合には、安衛法違反は問われないと解しました。刑法の大原則である罪刑法定主義との兼ね合いでかなり狭く解したわけですが、刑事事件ではそのように解釈されたとしても、災害防止という観点からすると、管理責任の所在を明確にすべきと言えるのではないかと考えます。その辺りのことを後掲の考察の部分で書いています。適用の実際についても、三柴先生の調査結果を踏まえて加筆する予定です。

考察と結論ですが、私の現時点での理解としては、改正の提案について第22条それ自体よりも規則のレベルで整理・統合すべき点があり得るのではないかと思うところです。特別衛生規則の整理・統合によって、より分かり易くする必要がある旨指摘されているところですが、それが非常に難しいものと捉えています。特別衛生規則は、新たな災害の発生によって、また新しい化学物質の登場によってその都度補充・追加されるという形で内容的にアップデートしてゆく性質があります。また、適用がかなり細かくなっています。たとえば、アスベストなどは当初特化則によって規制されていたところ、作業のやり方が従来のものと変わってくることによって、どんどん細かくなってきています。また、有機則と特化則については、ある物質の濃度のパーセンテージ如何によって適用される規則が異なるという、非常に複雑な様相を呈し、適用関係が分かりづらくなっています。この点、各規則の整理・統合という提言を示せたらと思いましたが、関連規則は非常に細かく、しかも日々アップデートしているという特徴があるため、今のところこれらをどのように整理すべきか、非常に悩んでいるところです。これら規則の特徴は、

災害予防という観点からすれば危害の特徴に応じた詳細な定めは非常に効果的と思われませんが、他方で複雑すぎて分かりづらいという側面もあります。これらについて、どのようにすれば分かり易く、なおかつ予防効果を維持した規則にできるのか、非常に悩ましいところです。この辺りが一番の課題ではないかと思われます。整理・統合を提言する場合には、どの点に主軸を置くかをはっきりさせなければならぬと考えています。

考察・結論部分の裁判例に関しては、特別規則や通達等が要請する措置を講じたか否かが問われる安配義務違反がらみの事案が中心になります。基本的には衛生規則に違反していれば安配義務違反が認定される事案が多いようです。騒音のように衛生規則等に規定のない場合は、厚労省が作成した安全衛生のしおり、あるいは通達などを用いながら安配義務違反を認めている事案があり、こうしたことから安配義務違反を認めるための根拠は規則以外にも広く存在することがうかがわれます。他方、使用者の義務違反があったとしても、労働者の不注意ゆえに過失相殺を行う事案もあります。ただ、会社側がそもそも安全措置を怠って危険を放置した状態で、なお労働者に一定の注意を要求していると言えるのか、そう読める判決もあるのでその辺りはひとつ指摘できることがあるのではないかと思います。先ほど触れた第23条関連の刑事事件の話ですが、この事件のように元請、下請、あるいは所有者といった多くの人が一つの作業場で就労するケースは少なからず存在するため、企業横断的な災害防止措置についてより一層の考察が求められるのではないかと思います。先ほども述べたように、刑事事件ゆえにあまり広く解釈することはできず、あくまで自社の労働者のみを対象とした安全措置なわけですが、こういう事件での横断的な責任の所在を明確化する必要はあると考えます。

このほか、局所排気装置やプッシュプル型換気装置、保護具など、分かり易いように図で掲載しています。また、有機溶剤の複雑な分類の図表や騒音障害防止用の保護具の分類なども掲載しています。

私の分担箇所の進捗状況は以上のとおりです。

三柴 ありがとうございます。まず私から、統括者としてのお願いをお伝えします。用語解説や図表をさらに充実化させていただきたいということです。特に、化学物質関係では文系事務系の人間にとっては馴染みのない用語がたくさん登場しますので、そういうものについて報告書でいくつか例示していただきましたが、さらにご尽力いただきたいということです。それと、判例をかなり取り上げてくれたのはありがたいと思いますが、取り上げた判例が当該条文の趣旨を解説する文脈とどう関わるのかを明確化していただきたいです。それが今一つ不十分な報告書が散見されます。要するに、何のためにその判例を取り上げたのか、そしてその判例は解説の趣旨とどう関わってくるのかということです。判例の数は少ないゆえに、そうした作業はやや強引になってしまいがちですが、関連性の説明は必ずしてください。

森山 監督官のご報告に話が戻ってしまって恐縮ですが、先ほどのご報告で提示していただいたスライドは、報告書に掲載しても差し支えないでしょうか。

森山 はい。必要に応じて載せるという形がよろしいかと思います。

三柴 あのまま載せるとまずいでしょうか。

森山 載せる図を選んでいただいて、後でそれを私が修正するという形でいかがでしょうか・・・どうし

てもということであれば、構いませんが。

三柴 恐縮です。報告書は作成の時間があまりとれないものですから、そのまま掲載させていただきます。

森山 了解いたしました。

三柴 それでは、あらためて佐々木先生のご報告に戻します。内容面のお話ですが、このプロジェクトを通じて労災を防止するという目的との関係で、法と規則との関係をどう考えるかが大きなテーマであることは把握されていると思います。どこから切り込んでも、どの条文を取り上げても、結局この問題に行き当たるわけです。法は一般的でアバウトなことしか書けませんから、規則でその具体的内容を特定しようとするのですが、他方で特定性が強すぎるとせつかく法が適用範囲を広くしようとした趣旨が滅却されてしまいます。なので、規則が特定していない内容でも、法の一般的定めでカバーされるのであれば、その内容を適用すべきであると言い得るわけです。ただし、一般的内容で刑事罰を課すのは無理なので、監督官が専門的知識をもって、あるいは専門家の力を借りて、リスクとは何かを認定して手続の中で罪刑法定主義の要請を充たす、といった内容を前回の報告書で提言しました。安衛法第98条・99条にある「急迫した危険があるとき」のように死文化してしまっているような条文を、個々の法や規則の運用に応用していこうという話ですが、以前提出した報告書の趣旨をもう一度踏まえて検討してください。それとの関係でいうと、新しい技術が常に開発され、新たな最先端のリスクを規制していくことが難しい中で、胆管癌の問題などもそうですが、発がん性の指定が適切になされていなかった状況下で起きた問題なので、結局安全衛生行政は産業医を選任していなかったとか衛生委員会を設置していなかったとか、手続き面の瑕疵を問責して処理しました。要するに管理体制違反を言っているわけです。安全衛生の実効は、管理体制づくりと基準づくりとの両面で測られてきたわけで、日本でもイギリスでもそこが力を持ってきたということが分かっています。だから、ハッキリした基準を定めることができない問題については、管理体制で対応する仕組みは一応できているわけです。管理体制というものを手続の一環と考えると、人的な対応を充実させるという方法もあるわけです。そういう方法も踏まえて、法と規則の関係を、労災を防止できるようにするためにはどのように考えるべきかが重要なポイントなので、よく掘り下げて検討していただきたいと思います。

先生方から他に何かご意見・ご質問ありますか。

畠中 さきほど事務所衛生基準規則について、重要な規則であると仰いましたが、その着眼点は大事だと思います。事務所労働者の数は非常に多いです。そういう意味で、私も事務所衛生基準規則は非常に重要な規則であると思っています。附則を見ていただくと省令施行は昭和47年とあります。しかし、それは単に安全衛生法施行の際に規則を全部出し直したために、昭和47年に統一されているだけの話で、事務所衛生基準規則はそれ以前にすでにできているわけです。確か昭和46年だったと思います。この規則の制定の背景ですが、たしか昭和43年・・・国会での成立が遅れたとしたら昭和44年、45年かもしれませんが、ビル管法、正式には「建築物における衛生的環境の確保に関する法律」（昭和45年法律第20号）という法律が制定されて、言わばその「労働版」ということで労基法に基づいて昭和46年

に事務所衛生基準規則が作られたと言えます。ですから、その辺りの沿革についても調査した上で執筆された方がよろしいのではないかという感じを受けました。

佐々木 ありがとうございます。

三柴 そうすると昭和47年よりも以前に、ビル管法を踏まえて制定されたときの議論や趣旨を示す資料をどなたかお持ちでしたらご協力お願いできればと思います。

藤森 一点よろしいでしょうか。今畠中先生が仰った件ですが、私の横断的課題の検討で前々回お話ししたときに、そういったことの対象から事務所則は除外した方が妥当ではないかという受け取り方をしました。本日の佐々木先生のご報告は逐条解説の文脈で事務所則を取り上げたわけですが、その辺少々分からなくなってきましたので、ご教示いただければと思います。すなわち、前々回の労働衛生関係の特別規則の趣旨と概要、統合の可能性ということで報告させていただきましたが、対象とすべき特別規則の中に・・・

畠中 要するに「特別衛生規則」という分け方をしますと、安全衛生規則以外の労働衛生関係の規則は全て特別衛生規則の側になだれ込んできます。たしか11本あったと思いますが、しかし、その11本の中でも事務所衛生基準規則だけは全く別格のものですよね。有害業務を規制する規則ではなく、事務所の環境などの労働環境を定めた基準なわけです。現行の事務所則を見ていただくと、トイレの数などに関する規定もあったかと思いますが、まったく性格が異なるものですから、11本というより「10本+1本」といった方が正確です、という話になると思います。

三柴 趣旨が違うからこそ、逐条解説では取り上げる価値が高いけれども、特別衛生規則をまとめるということになると、趣旨が違うからこそ省略しても差し支えない、ということでしょうか。

畠中 まさにその通りです。

藤森 今のお話を踏まえてよく検証させていただきます。ありがとうございました。

三柴 それでは、佐々木先生のご報告はここまでとさせていただきます。本日は急がずに時間の範囲内で行けるところまで行こうと思います。それでは、次に山本先生にお願いいたします。

山本 今のところペーパーがないので口頭で進捗について報告させていただきます。また、先生方にご相談させていただきたい部分がございます。私の担当は安衛法第26条、第27条、そして第104条および第105条となっています。第26条は、労働者の危険・健康障害を防止するための措置に関して労働者の協力義務を定めた規定ですが、工場法および旧労基法にも同様の規定があり、旧労基法のコメントールにも当たりながら調査しているところです。労働者の義務を定めた部分で、これらの法規定から義務が生じると思われますが、職場で使用者がこれを規律するのに就業規則、あるいは現場で持たせ



ている手帳やハンドブックといったものに記載があるのか否かも調査したいところですが、この点もし先生方でご承知の点があればご教示いただきたいと思います。第27条も第26条と同様、古い歴史があるということなので、この辺りを調査している最中ですが、条文中「公害」という文言が見受けられ、正確には第2項に「厚生労働省令を定めるに当たっては、公害（環境基本法（平成五年法律第九十一号）第二条第三項に規定する公害をいう。）その他一般公衆の災害で、労働災害と密接に関連するものの防止に関する法令の趣旨に反しないように配慮しなければならない」という文言があるところ、これが挿入された経緯が不明です。コンメンタールにも詳細はほとんど書かれていません。時期的に時代的な背景は分かるのですが、この点もしご存知の方がいらしたら、あるいは参照すべき資料などお教えいただければと思います。裁判例を探しても、第26条や第27条関連はヒットしないので、探すとすれば共同不法行為などで労災が発生した際に、関係労働者の責任を問う事案が考えられますが、明確に第26条違反としてヒットするかどうか定かではありません。このような判例を記載すべきかどうかについてもご指示いただければ幸いです。

第104条、第105条は、健康診断等に関するプライバシー保護等の規定で、第104条のほうは資料が揃ってきています。第105条はかつて1回削除され、その後働き方改革の一環として復活したという経緯があり、労基法ではこのようなことはあまり見受けられません。三柴先生も関与されましたが、厚労省が「事業場における労働者の健康情報等の取扱規程を策定するための手引き」（<https://www.mhlw.go.jp/content/000497426.pdf>）を発行していますが、これを引用すべきと考えています。ただ、分量が40頁にも及ぶため全文の引用は難しく、添付資料とするにとどめた方がいいのかどうか相談させていただきたいと思います。現在はこのような形で法令の趣旨を追っているところですが、第104条の指針の内容は、おそらく健康診断やストレスチェックを担当する専門家もかなり援用するのではないかと思います。指針等の根拠規定はこっちにあるけれども、実際の適用の場面は各法令の方に入ってくるので、そちらとの重複をどうすべきかご相談いただければと思っています。

周回遅れでようやく執筆に着手した状況なので、その辺はご寛恕いただければと思っていますが、できる限り速やかに形にしたいと思いますので、よろしく願いいたします。

三柴 ありがとうございます。まず私の方から第104条、第105条関係について、商事法務研究会発行のNBLという雑誌がありますが、そこに私と弁護士の岡村先生との対談が掲載されています。最近打ち出された政策の趣旨などがコンパクトに書かれていますので、マニュアルの全部ないし一部をコピーするのではなく、そこに載っているものをご参照いただくのが早いかと思います。また、第26条・第27条、とりわけ公害規制と安衛規制との関係を述べたところについては、畠中先生ほかご存知の先生にご示唆いただけるとありがたいのですが。

畠中 第27条第2項に関しては、労働安全衛生法施行の事務次官通達（労働安全衛生法の施行について（昭47・9・18発基第91号））に書かれている以上のことはありません。むしろこの通達にハッキリと分かりやすく書いてあります。要するに労働安全衛生基準の中には公害防止に資するものがあり、そういうものについては公害防止基準を勘案して定められなければならない旨書かれています。

山本 ありがとうございます。第27条に基づいて多くの省令を列挙するに当たって、条文を全部引用

した方がいいのか、それとも一覧表にした方がいいのか、その点は他の先生方と平仄をあわせたほうがよろしいでしょうか。

三柴 基本的な方針としては、全文コピーは避けたいところです。何か重要な資料があるとしても、文脈との関係で必要な部分を自分の言葉でまとめ直すようお願いしたいと思います。コピーだけだと資料にはなるけれども研究にはならないので、あくまで自身が執筆している解説の文脈に関わる限りで自分の言葉でまとめ直してください。ただ、原文を示すことに意味があるというのであれば、その限りで引用していただいてもかまいません。

他に何かお尋ねはありますか。

山本 職場で使用者が労働者に安全衛生の遵守義務を課するためのツールのようなものがどこかにあるかという質問なのですが、いかがでしょうか。

三柴 この問題については、篠原先生いかがでしょうか。

篠原 就業規則であれば一般的に普及しているものには書かれていると思います。

山本 職場で労働者に持たせるような小冊子や手帳のようなものを書いてあったりするのでしょうか。

篠原 事故などが起きると、あまりにも一般的な内容では広すぎてしまうので、小冊子などを会社が作ることがあります。建設業などではそうしていると思います。製造業でもフォークリフトを使っていて、事故が発生するということであれば、中災防が発行しているものもあるし、会社が作る場合もあります。そこに一般的ルールと会社内のルールを記載し、誓約書を書かせる会社もあります。

山本 なるほど・・・

篠原 余談になりますが、安衛法上労働者を処罰する規定がありますが、私はかつて1件だけ送検したことがあります。車両系建機を無資格で運転していたところ、会社いわく「練習させていた」とのこと。練習はさせていたものの、本来的な業務では使わずに、労働者が作業終わってから移動させた、それに対して会社はそのような指示はしていない、と主張していました。ところが事情を聴取していくと、無資格でその労働者が使用していたにもかかわらず、会社はそれを止めさせなかった。ご家族の会社に対する被害意識が非常に強かったので、安衛法第61条第2項（※下記参照）を根拠に、家族の了解を得て労働者を送検したことがあります。だから、第26条関係で違反したのが労働者だったとしても、会社にも両罰規定が及んで有罪判決が出る可能性がありますので、会社が違反を否認する場合に家族の被害意識が強い場合に刑事訴追がなされるのかもしれない。

第61条 ① 事業者は、クレーンの運転その他の業務で、政令で定めるものについては、都道府県労働局長の当該業務に係る免許を受けた者又は都道府県労働局長の登録を受けた者が行う当該業務に係る技能講習を修了した者その他厚生労働省令で定める資格を有する者でなければ、当該業務に就かせ

てはならない。

② 前項の規定により当該業務につくことができる者以外の者は、当該業務を行なつてはならない。

山本 ありがとうございます。

三柴 今回の送検のお話は、労働者が被災したり亡くなったりしたケースでしょうか。

篠原 亡くなったケースです。

三柴 無資格でクレーンを運転していて・・・

篠原 車両系の重機です。20代の若い方で、資格を持っていませんでした。

三柴 その人の運転ミスで、別の人が無くなったというわけですね。

篠原 いえ、その20代の方が亡くなったのですが、会社は作業をさせていませんでしたが、本人は練習しながらしていました。それをみんなで教えていました。事故が起きたのは、作業が終わってからその機械を置く場所に（会社いわく）“自主的に”移動させたその時に、トラクターショベルと一緒に斜面から転げ落ちて死亡したわけです。これについて会社は、そんなことは指示していないと言い張ったわけです。

三柴 なるほど、ありがとうございました。山本先生から従業員向けの啓発ツールのようなものについてお尋ねがありましたら、今後篠原先生にご助力いただければと思います。

畠中 今回の件でひと言よろしいでしょうか。安衛法第4条に労働者の責務が書かれています。いわく、「労働者は、労働災害を防止するため必要な事項を守るほか、事業者その他の関係者が実施する労働災害の防止に関する措置に協力するように努めなければならない」。この労働者の責務規定は、政府提出原案では「措置に協力するように努めなければならない」という部分が「措置に協力しなければならない」という規定になっていました。それが衆議院社会労働委員会において修正され、「努めなければならない」に変わったという経緯があります。

三柴 原案はイギリスの安衛法と同じですね。原案はそう練ったものの、日本流に改められたというようにうかがいました。

畠中 それと、安衛法第105条の守秘義務の立法経緯ですが、旧労基法時代は法律にはありませんで、旧安衛則の中で健康診断の守秘義務が規定されていました。法律上の根拠がないものですから、罰則の対象となりようもありませんでした。これを安衛法制定時に法律事項に格上げしまして、健康診断等の「実施の事務に従事した者は、その実施に関して知り得た労働者の秘密を漏らしてはならない」と定め、罰則を設けたという経緯になっています。旧労基法時代前、工場法時代はどうだったかということ、工場法

施行規則に健康診断実施の義務付け規定とあわせて守秘義務規定も置かれていました。これには罰則が付いていました（工場法施行規則第8条の7、第27条の2）。なので、旧労基法時代にいったん罰則がなくなり、安衛法で復活したということになります。執筆の際には、このような立法の経緯なども留意されてはいかがでしょうか。

山本 ありがとうございます。

三柴 健診等に関する守秘義務については、「正当な事由がない限り」という文言がないのはなぜなのでしょう。医師法や刑法第134条など、守秘義務規定のほとんどは、「正当な事由がない限り」秘密を漏らしてはならないと規定されているのに、安衛法は“全面禁止”のような書き方になっています。この点について問題提起したことがあり、事務局で検討することになったのですが、明確にはねられました。健診結果というのは基本的に病気を見つけ出すというものではないので、秘密を守ることを優先するのは理解できるのですが、場合によっては医師の良心で、たとえば情報共有した方が健康管理に資すると判断するケースもあると思います。にもかかわらず、正当事由という例外も一切認めないのはなぜなのでしょう。刑法上、正当事由があれば免責されるという一般規定があるために、それを援用すれば大丈夫ということだったのでしょか。

畠中 結局、旧安衛則の中にあった文言をほぼそのまま踏襲しています。ただ、工場法施行規則の時代には、「故なく」という文言が入っていたのですが・・・。

三柴 この点はあらためて検討する必要があるそうですね。他によろしいでしょうか。

角田 先ほどの従業員啓発のための“ツール”に関するお話です。篠原先生も仰っていたが、私たちが足を運ぶのは建設現場が多いのですが、新規入場者教育を実施しています。基本的には各事業者がやるべきことですが、だいたい元請が実施している場合が多いです。その際に、職場や現場における安全に関するルールをペーパーにして、新しく入ってきた人には誓約書にサインさせるということが、建設現場で一般的に行われています。その内容について、大体どのような感じのものか、私が使っているものを提供できますので、参考になればと思います。

山本 ありがとうございます。ぜひよろしく願います。

三柴 角田先生が今仰ったものは、特別教育とは別途のものなのでしょう。

角田 各現場で実施するもので、基本的には元請の会社ごとに内容が多少変わりますが、現場ごとの基本的ルールです。たとえば、喫煙場所はどことか、くわえ煙草で仕事してはダメとか、基本的なことが書かれています。

三柴 それは安全衛生目的で、なおかつ違反した場合には事業場内での不利益措置もあり得るというも



のですか。

角田 厳しいところでは、違反が繰り返されると入場禁止になることもあります。

三柴 ありがとうございました。それでは、山本先生のご報告はここまでということで、次に阿部（未央）先生をお願いします。

阿部 私の担当は第69条から第70条の2で、できれば快適な職場環境の問題についても取り組む予定です。本日は第69条から第70条の2に関する経過報告をさせていただきます。これらの条文は、健康保持増進措置ということで、昭和63年（1988年）の安衛法改正時に新設されたもので、他の条文に比べると新しい条文になっています。ざっくり言うと、健康保持増進措置やメンタルヘルスに関する規定は、有害物質や就労場所、設備、機械など物理的安全に関する規制と異なり、健康指導や生活習慣の改善に関する取り組みを目指して規定されたものです。1988年になぜこうした健康保持増進措置が新設されたかという点、一つには高齢化が進んで高齢労働者が増加したことで、運動機能の低下した労働者が安全に勤務する措置が求められたからです。もう一つには、PCなどの技術革新によって作業環境が急激に変化したことへの対応です。

健康保持増進措置というのは心と体の健康づくりということで、「トータル・ヘルスプロモーション・プラン（THP）」というものが推進されています。昭和63年に「事業場における労働者の健康保持増進のための指針」が出ていて、メタボの予防のように勤務時間中だけでなく日常生活における健康保持なども念頭に置いたもので、広く一般的な健康づくりも含んだ指針です。この指針は令和2年に改正され、①個人から集団への視点が強化されたこと、②健康に関心を持たない無関心層への取り組み、③若年期からの運動の習慣化の必要性、といったことが主な改正のポイントになっています。中小企業などでは職場内に施設や人員がない場合があり、一方でスポーツジムなどは多いため、事業場外の資源も有効活用すべきとする視点も打ち出されています。

第70条は、レクリエーション活動や体育活動についての規定です。第70条の2は、第69条第1項所定の措置に関する指針を公表する旨の規定ですが、私の報告書の中ではここでメンタルヘルスの指針について少し詳しく記述しています。メンタルヘルス指針については、2005年の安衛法改正時に新たに加えられたものになっています。安全衛生においては重要視されている一方で、この指針に基づいて重要なメンタルヘルス関連の指針が出されているので、根拠条文としては弱いものかもしれないと感じています。

沿革と制度史になりますが、健康保持については、もともと70年代のシルバーヘルスプランということで、中高年者を対象に中災防で取り組みが行われ、その後80年代にトータル・ヘルスケアということで、全年齢層を対象とした健康対策を行うことになりました。それまでは「早期発見」のような消極的な対策だったものが、積極的な健康づくりや体力づくりのように、すなわちネガティブヘルスケアからポジティブヘルスケアへ、また職場だけではなく日常生活全般においてメンタルヘルスもあわせた健康管理を行っていくということが、80年代から言われるようになりました。

メンタルヘルスについては、2000年に指針が公表されています。この指針は、2006年の指針が改正安衛法という法律上の根拠があるのに対し、法律上の根拠がない状態の中で、初めて心の健康づく

りのために策定されたものです。その背景には、電通事件や99年の精神障害の労災認定に関する指針が出されたことなどが大きく影響していると考えられています。メンタルヘルス対策が法令ベースになったのは2006年の指針が初めてということです。背景となった事故については、1982年の羽田沖航空機墜落事故が影響していると言われています。この事件では、航空機の機長が統合失調症に罹患して発生した事故であると言われています。そこで、精神疾患で投薬治療が行われていたことが認識され、心の健康管理に注目が集まりました。

適用の実際については未了です。関連判例として、検索した限りではメンタルヘルス指針に言及した判例が1件しか見つからず、三柴先生からもメンタルヘルス全般の判例についてもっと取り上げた方がいいのではないかとということで、電通事件や東芝（うつ病）事件などを取り上げようと思いました。ただ、そうすると判例の数は膨大になり、取捨選択についてご相談できればと思っていました。報告書で取り上げたティー・エム・イーほか事件（東京高判平27・2・26労判1117号5頁）は、派遣労働者の鬱病疾患と自殺に関する事案ですが、派遣元・派遣先双方について一部責任が認められました。判決から汲みとり得る示唆として、労働者の体調不良の原因や程度等を具体的に把握し、必要に応じて産業医の診察を受けさせるべきであったとして、その限度で両事業者の安全配慮義務が認められたということで、自殺に関する責任は否定されましたが、その手前の段階における義務違反が認められたという事案です。この事例では、労働者が自ら不調を訴えていなかったために、会社側も具体的な措置がとりにくかったのですが、東芝（うつ病）事件の後に下された判決ゆえに同事件の影響を受けたものと思われます。メンタルヘルス指針に言及したのはこのティー・エム・イーほか事件のみです。電通事件も取り上げようと思っていて、ご承知のようにメンタルヘルス事案のリーディングケースと言えます。安衛法の条文としては、第65条の3に言及しているのですが、他の先生の担当箇所と重複する可能性もあるため、どういう形で取り上げるかという問題もありますが、電通事件がメンタルヘルス指針策定の契機になったという点では、私の担当条文とも関連すると考えています。

考察の箇所では、メンタルヘルスケアについてはその重要性が認識されながらも、安衛法の規定はふわっとしたものになっているという点で、もしかすると独立させた規定というものがあつた方がいいのではないかとというのが、現時点での所感です。

先生方にお尋ねしたい点としては、判例をどのように取捨選択するか、また中災防や安全衛生情報センターにおいて健康増進措置の取組みがなされているようですが、実際にどのような取組みがこれらの条文に基づいてなされているのかがイメージできなかつたので、ご存知の先生がいらしたらご教示いただければと思います。

私の報告は以上になります。

三柴 ありがとうございます。まず、取り上げるべき判例ですが、拙著『職場のメンタルヘルスと法』の159～174頁に判例を整理していますので、ご参照ください。また、第69条が設けられて以降のこの条文を契機とした政策展開については、同書138～152頁にまとめています。これもご参照ください。また、社会調査の結果も152～158頁に載せています。防災団体や健康安全機構のように厚労省の外郭団体や関係団体が実施している施策については、概ね私も関わっていますので、概要はお伝えできます。要点をいうと、まず防災団体の方は基本的には研修事業が中心です。出版も行っていますが、力を入れているのは研修です。事業場に赴いてコンサルティングをすることもやっています。健康安全

機構の方は、全国に産業保健総合支援センターを設置しています。そこで、メンタルヘルスとか両立支援とか、政策展開のための委託事業が展開されていて、促進員や相談員が設置されています。こういう人たちが、電話相談に応じるほか、実際に委託を受けた場合には一部無料でコンサルティングのために赴いてくれます。研修講師も行います。基本的には政府が作った取り組みのための計画を根付かせるためにそのような指導を行っているという形になっています。社労士、産業カウンセラー、保健師などといった人たちが担当しています。篠原先生は、京都産保センターの促進員です。こういう事業が委託事業として展開されています。産保センターは医師会と連携していて、センターの所長は概ね地元の医師会のトップの方で、副所長はベテランの監督官ですが、最近は若い監督官も就任しています。産保センターも数多くの研修を実施して、ソフト面での政策は研修が重要になりますので、この点災防団体とかぶっています。

ざっくり言うと以上のとおりですが、より詳細な情報は今後私にご質問いただければと思います。

阿部 ありがとうございます。場合によっては、私自身が仙台や山形の産保センターに足を運んで・・・

三柴 大変結構な試みだと思います。山形にも宮城にも産保センターは設置されています。

阿部 そうやって収集した健康増進措置や研修の活動の詳細は、どこに執筆すればよろしいでしょうか。「適用の実際」でよろしいでしょうか。

三柴 「適用の実際」ではあるけれども、条文解説の後ろの方に、その条文の運用の在り方として書き加えてもいいかもしれません。条文の趣旨として付加的な説明とした方がスッキリするのではないかと思います。

それでは、阿部先生のご報告はここまでとして、本来であれば、石崎先生、井村先生、阿部（理香）先生、南先生、鎌田先生、内藤先生にご報告をお願いすべきところ、時間の都合上ここまでとさせていただきます、今後の予定についてお話したいと思います。森山監督官はMLに追加させていただきますので、今後もしもご関心がありましたら是非ご参加いただいて、必要に応じてご意見いただければと思います。次回は2月27日の同じ時間を予定しています。

横断的検討課題についてですが、色々テーマ設定を試みましたが、一部について詳しい方に講演していただいて、講演録をもって代えるという形でもいいのではないかと思います。そういう方法もありなのではないかと考えています。

（※この間、進捗状況に関して若干名の先生とやり取り）

最後に安衛法の展開について図を作成したので（※下図参照）、これを簡潔にお伝えして終わりたいと思います。安衛法も道交法もいずれも保護法益（法によって守ろうとしている利益）は、本人や周囲の生命、身体、財産がその中核になっています。それ以外にも、安全の秩序作りという目に見えない財産を守ろうとしている面があると思います。たとえば、たいして危険のない速度違反や駐車違反を厳しく取り締まったりしますが、リスク対応というよりは秩序の形成が目的であると言えます。人間はすぐにダレてしまうから、引き締める必要があるわけです。安衛法もそういう側面を持っているだろうと思います。旧安衛則時代は技術者が考えた再発防止策をそのままルール化した性質のものであったわけですが、重

大労災が多発していました。そこで、畠中先生らのご尽力によって、「場と組織の管理体制づくり」を取り込んだ安衛法が制定されました。これは相当に安全の秩序づくりに貢献したと思います。交通安全においては、3E対策すなわち「交通管理・交通工学的的手法(Engineering)」、「法の執行(Enforcement)」、「教育(Education)」の組み合わせによって秩序を作っていく、つまり心理的な働きかけも重視していくということ。安衛法でも同様に展開されてきたものと思います。

安衛法の骨子は、自主的取組み、管理体制の整備、危害防止基準の充実、作業環境改善等であるわけで、これらが相まって安全の秩序づくりに貢献する形になっていきました。ところが制定当初の形はその後変化します。現場で起きるのは対応が難しい衛生問題や健康問題に変質し、以前から存在していた問題も顕在化しました。ということで、専門家の活用を重視するリスク管理に歩みを進めていきました。その典型が作業環境測定法、長時間労働者対象の面接指導制度、あるいは最近できたストレスチェック制度であると言えます。

さらに時代が進み、伝統的労働災害は減る一方、産業構造、経営環境、働き方が変容して、安衛法の目的は今や単なる労災防止にとどまるものではなく、労使双方のQOLとかステークホルダーも含めた関係者のQOL/QOWLを改善することも射程に収めるようになっていきました。いい例が両立支援策ですね。あるいは、副業・兼業・フリーランスなど、かなり詳細な部分にまで安衛法が触手を伸ばすようになっていきました。労使以外の様々なステークホルダーを巻き込む対策になっているわけです。こうした展開を通じて取り組みが進んでいることと言えば、安全衛生基準の整備は発展の一途をたどっています。安全衛生技術も発達しています。これらについて、イギリスでも安全衛生政策に詳しい人は、災防効果を認めています。また、技術的課題から社会的課題、すなわち労働時間や生き方、働き方といった課題への移行も進んでいます。

しかし、積み残した課題があります。本日森山監督官からお話がありましたように、リスクを作り出す人やリスクに影響を与えられる人が管理責任を負担するという大原則・・・イギリスでは法に明確に書かれている大原則であり、日本でも安衛法第3条に明記されている大原則が、なかなか具体的に展開していないということです。それと、経営者・組織の意識・知識の向上。さらには未解明のリスク対応。また、規制の過不足の解消。以上のようなものが課題として残っていると考えています。規制のやり過ぎ、不要な規制が残っていることは、実は安全衛生秩序との関係ではいい面もありますが、やはり死文化した条文が増えると現場の遵守する意識が薄れていくという問題もあるので、この辺は考えていかなければならないでしょう。

本日の会合は以上になります。長時間にわたって有意義なご議論ありがとうございました。



### 安衛法の展開

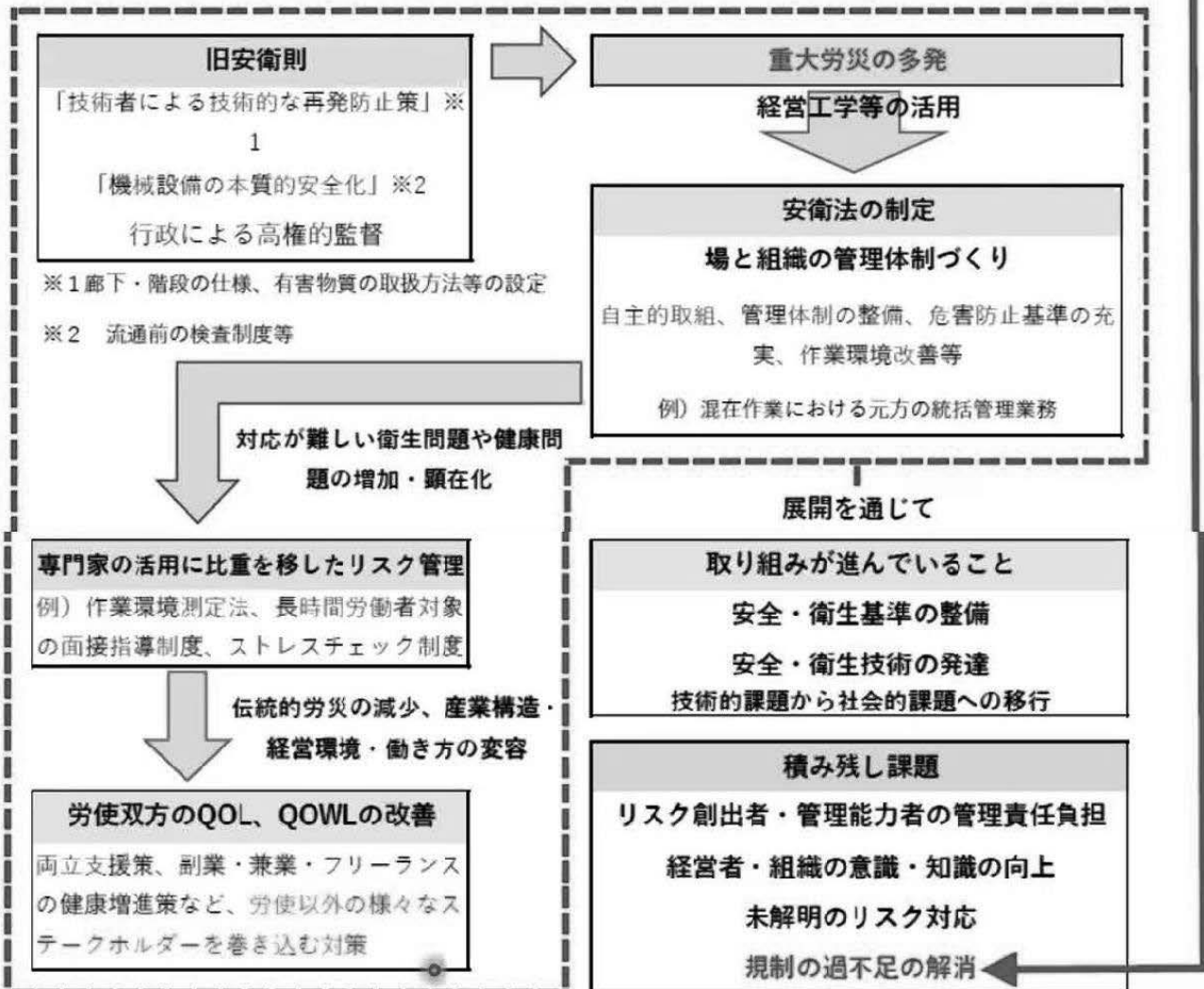
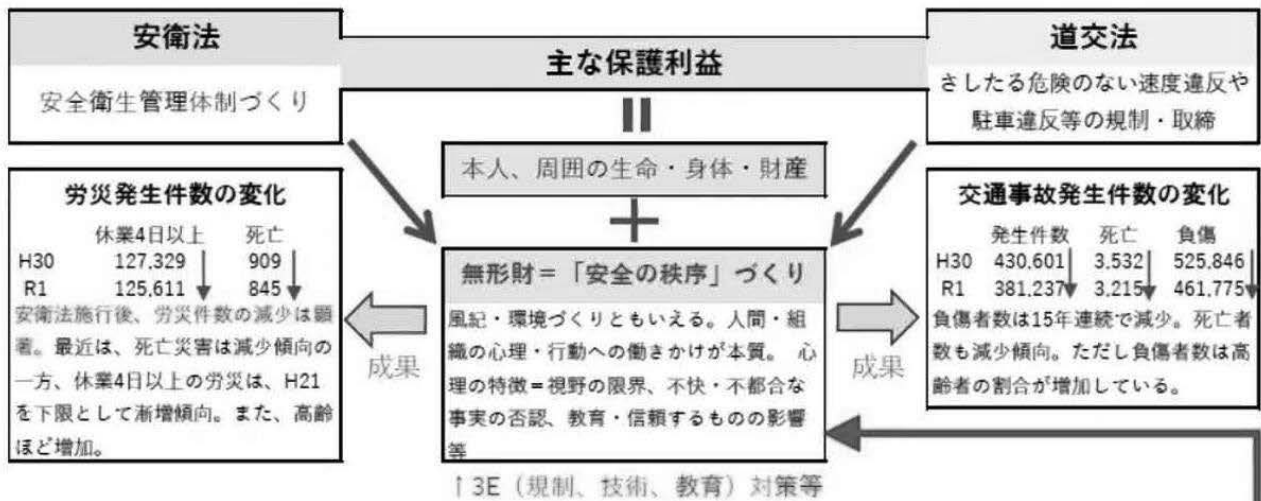

三柴 本日もご多用中のご参集ありがとうございます。本日開催要項を配信させていただきましたが、それに沿って進めたいと思います。最初に分担報告書の執筆をお願いしている先生宛に、私の方から留意点をお伝えし、その後に玉泉先生と藤森先生から本日のメインイベントである特別報告をいただき、研究経過報告を担当の方にお渡し、最後に2021年度の開催要項についてお伝えしたいと思います。内容的には普段より少々早く終わるのではないかと思います。

まず報告書執筆上の留意点をお伝えします。前回も含めこれまで幾度も強調させていただきましたが、このプロジェクトから生まれる体系書は幅を持たせたいということです。特に現場のリアルがみえるものにしたい、これによって技術者中心の法制度であったものを事務系にも親しみのあるものにしようという試みです。単に条文と解釈例規が並んでいるというスタイルではなく、判例、実例、運用実態を徹底的に書き込んでください。条文の解説においても、それが反映したような内容になるよう心がけてください。そのために、本年度は運用実態について行政官や行政官OB向けの調査を行ったところですが、まだ資料として整理はされていませんが、調査結果については共有させていただいていますので、これを適用の実際の項目に活用してください。引用方法はここに書いたとおりです。

また、今お伝えしたような趣旨から、技術的な用語は法的な用語も含め、その分野に詳しくない人が見てもスッと頭に入ってくるような内容形成に努めてください。特に用語解説を徹底していただきたいということです。ご自身の分野においては使い慣れた当たり前の用語であっても、他の分野の人から見ると全く理解できないことも多いので、その点ご留意ください。それを含めて平易な表現に努めてください。特に法学系においてはご留意いただきたいと思ってまして、言うことかかない人を論理で抑え込むという分野ですから、どうしても堅苦しい表現になりがちですが、そこはあえて平易な表現に努めて内容を伝えることが大事なんだということをご銘記いただければと思います。

以上が報告書執筆の際の留意点です。次に特別報告に移ります。最初に玉泉先生からご報告いただきたいと思います。タイトルは「現場でのリスクの見極め方」ということでご講話をお願いしています。玉泉先生は、現在近畿労務安全衛生研究所の所長であり代表であるというお立場で、もともと労働基準監督官をお務めでした。近畿圏で安全衛生といえば、まず玉泉先生のお名前が挙がることが多く、この分野に非常に精通された先生であるとの定評がございます。

それでは、よろしくお願いいたします。（※共有画面に玉泉孝次「現場でのリスクの見極め方について～リスクの発見・見極めの要諦は知識と経験（広く深く）～」、以下「玉泉資料」とする）

玉泉 よろしくお願いたします。テーマが「現場でのリスクの見極め方について」ということなので、私の行政実務の経験などをもとにお話したいと思います。私は現在、安全衛生関係の仕事が半分、人事労務関係の仕事が半分、といったペースで進めています。玉泉資料冒頭の副題に「リスクの発見・見極めの要諦は知識と経験（広く深く）」と書きました。この「広く深く」というのは、昭和49年に監督官に着任し2カ月間の研修を受けましたが、そのときに安全衛生部から来られた講師が「安全は広く深く」・・・「広く浅く」でもなく「狭く深く」でもなく、「広く深く」勉強しないと指導はできない、というお話をされました。今でもその当時のノートに書いてありますが、これを肝に銘じて仕事に取り組んでいました。昭和49年は全員で50人ほど採用され、その3分の1が理系でした。私は文系で最初に着任したのが三重県四日市の監督署でした。コンビナートが27社ほどあり、安全衛生関係の仕事が非常に多い地域でした。昭和49年には四日市だけで1年間の死亡事故が48例、すなわち平均すれば週に1人亡くなっ

ている状況ゆえ、ほとんどが人事労務よりも安全衛生関係の仕事でした。当時の四日市は公害の問題もあり、死亡事故もあり、自動車産業も港湾労働もあり、様々な業種が数多く存在した中で大変勉強させていただき、それが現在の私の安全衛生のベースになっていると思います。当時の私は安全衛生は門外漢だったわけですが、「広く深く勉強せよ」という講師の言葉に従い、勉強を続けてきたつもりです。

内容に入っていきますが、見出しにあるように「1. 労働安全衛生規則などの各規則の条文は災害事例・リスクの宝庫」だということです。すなわち、災害事例の原因を構成要件化したものと言えます。これらを見れば、ほぼ災害のリスクが分かってきます。玉泉資料1頁にあるように、「規則の各条文に「してはならない」、「しなければならない」と定められている構成要件そのものに、リスクを発見・見極めるヒントそのものがあります」。たとえば、安衛則第101条第2項には「事業者は、回転軸、歯車、プーリー、フライホイール等に附属する止め具については、埋頭型のものを使用し、又は覆いを設けなければならない。」とあります。これを読んだだけでは、私たちがさっぱり分からなかったのですが、現場に行ってみると納得できました。たとえばキックワッシャーに服が巻き込まれたという事例もありました。ですから、およそ回転する機械には常に巻き込まれるリスクがあるということがここから分かると思います。次にボイラー則第19条ですが、「ボイラー室には、二以上の出入口を設けなければならない。」と規定されています。そして安衛則第546条には「危険物その他爆発性若しくは発火性の物の製造又は取扱いをする作業場及び当該作業場を有する建築物の避難階には、非常の場合に容易に地上の安全な場所に避難することができる二以上の出入口を設けなければならない。」とあります。このことから、危険な作業場以外であってもおよそ作業場には2か所以上の出入り口が望ましいことが分かりますし、現場に行けば対角線上に離れたところに設置をするよう指導できると思います。さらにこの条文では、「前項の出入口に設ける戸は、引戸又は外開戸でなければならない」とされ、事業附属寄宿舎規程第13条にも同様の規定があり、内開きの扉ではダメで、避難出入口は引戸又は外開戸でないと危険であるといったように、安全の基本的なところがわかります。さらに回り階段を禁止しているので(事業附属寄宿舎規程第17条)、この規定を根拠に現場でも回り階段は設置しないよう指導できます。酸欠則では、トンネルに入るときに入退場の人員の点検が義務づけられていますが(第8条)、点検の方法について何も書かれていません。そうすると、玉泉資料1頁に書いたとおり、名札を掲示して中に入っている人の名札は表面、退出した場合は裏面にするといった方法で、入退場者を把握するヒントが生まれます。以上のように、各規則を読み込むことによって、リスクを発見することができます。

しかしそれだけでは十分ではありません。安衛法の中には構造規格、技術指針、通達・ガイドライン等があります。これらも知らなければ現場での指導ができません。たとえば構造規格でいうと、鋼管足場用部材、エレベーター・簡易リフト、クレーン、丸のこ盤、研削盤、動力プレス、高所作業車、保護帽、ハーネスなどの構造規格、このほかにも安衛法第42条に基づく構造規格が数多くあります。それ以外にコンベヤー、ローリングタワー、墜落防止用ネットなどの技術指針、情報機器作業(VDT)の通達やガイドラインなど、知っておかなければ細かな指導ができません。こういうものにも相応のリスクが書かれていますので、それを知ることによってリスクを発見できる場合があります。

たとえば安衛則第147条です。第131条のプレスは「動力プレス」と言うのに対し、本条は「第147条のプレス」という言い方をしますが、第147条は「事業者は、射出成形機、鋳型造形機、型打ち機等に労働者が身体の一部を挟まれるおそれのあるときは、戸、両手操作式による起動装置その他の安全装置を設けなければならない。前項の戸は、閉じなければ機械が作動しない構造のものでなければな



らない。」と定めています。実際に現場では、戸があってもリミットスイッチが適切に作動しなければならないのですが、リミットを殺しているケースがいくつでもあります。また、両手操作式の起動装置は、戸が開まるまで押し続けなければならない構造であるかないかを見なければなりません。これは、動力プレス構造規格などを見れば、押し続けなければならない旨書かれています。両手操作式起動装置は、片手で操作できないように内内30センチ離していないといけません。そういった細かい内容も構造規格に書いてあります。これを知らないと、現場に行っても第147条に関する指導ができず、リスクを見逃してしまいます。

次にトラックの話になりますが、5t以上になると保護帽の着用が義務づけられています。逆に言えば、4.9tまでは必要ないということになります。保護帽には墜落防止用、飛来落下用、感電防止用という3つの構造規格があります。飛来落下用は頭のとっぺんに当たった物については効果があるのですが、横には弱いのです。他方、墜落防止用は横には強いので、トラックで作業する場合は、墜落防止用と飛来落下用の兼用を使用していないと、側頭部や後頭部を打ってしまいます。こういうことを知らないとい指導ができません。

玉泉資料2頁「3. 様々な業種や現場の経験、実際の事故・災害事例の経験を積む」に移ります。なかなか難しいことですが、できるだけ現場の経験を積むこと、実際に事故・災害現場を経験することによって、様々なケースを肌で知ることができ、同種災害、関連災害のリスク発見の眼を養うことができます。先ほど申しましたように、1年間で48例の死亡事故があった場所で仕事をしていたのですが、そこで様々な経験をさせていただきました。プレス屋さんには指が10本ともなくなっている社長もいました。その息子は3、4本欠けていました。そういった様々なケースを肌で知るとい経験が、災害やリスクを見る目を養ったのではないかと思います。玉泉資料2頁以降に掲載した「経験した事故・災害等の事例」は安全関係と衛生関係に分けて記載しましたが、こうした事故を知ることによって、あるいは災害調査に行くとかかなり細かく法令を準備し適用して、送検事例は送検せざるを得ないので、かなりの数の条文を読みこなすことで非常に勉強になりました。災害事例や事故事例を知ることがリスクを見る目を養うことになると思います。

玉泉資料3頁にあるように、現場のリスクは千差万別であり、製造業といっても食料品製造業、繊維製品製造業、木材木製品製造業、印刷業、土石製品製造業、鉄鋼業、金属製品製造業、造船業、非鉄金属製造業、電気・ガス・水道業などでは使用する機械設備も発生する災害も異なり、その業種にしかないめったに見ることができない機械があります。初めて目にすることで、初めてその機械の危険性を知ることになります。百聞は一見にしかずで、自身の目で見ないとリスクが分かりません。さらには、建設業でも土木と建築では業態が大きく異なり、土木の人は建築がわからず、建築の人は土木がわからないと言えるほど異なっています。土木であれば大型ダム工事から砂防ダム、河川工事、隧道工事（推進工法など）、山岳トンネル工事（NATM工法）、地下鉄工事、高速道路工事、橋梁工事、港湾工事、解体工事、建築であれば超高層ビル工事から一般ビル工事、マンション工事、一般住宅工事、リフォーム工事、電気工事、設備工事などがあります。それぞれに応じた、たとえばトンネルであればトンネルの崩壊や肌落ちのような問題があり、建築であれば墜落や感電事故など様々なリスクが山ほどありますので、現場に足を運ぶことによって、どのような場合にどのような危険が潜んでいるかが分かると思います。

そのほか、港湾貨物取扱業すなわち船内荷役や沿岸荷役といったところで揚貨装置を使ったり、デリック、クレーン、ストラドルキャリアなどを使います。採石業ではダイナマイトを使用し、運送業では積



卸しやフォークリフトの問題が生じ、病院では電離放射線、社会福祉施設では非災害性腰痛、競馬業では人間より馬の方が優先とうたわれますので噛まれたり蹴られたりといった事故が多いです。これらの業種・業態をすべて経験することは困難だと思いますが、できるだけ様々な業種の現場を経験することにより、その業種特有のリスクだけではなく、共通したリスクを水平展開に見つける目が養われてきます。

玉掛けをする場合は介錯ロープの端部を団子にしていると、フックを巻上げたときに介錯ロープが材料を引っ掛けて材料が跳ねたり、吊っている荷が揺れたりすることがあります。坂道に停車しているトラックのブレーキが甘いゆえに、転がってきて挟まれたり巻き込まれたりする事故は枚挙に暇がありません。佐川急便などは、水平な場所に止まっても輪止めを使用しています。それぐらいの措置を講じないとリスク管理はできません。事業者はどのような場所でもトラックを降りた際には輪止めをするよう指導しているので、危険防止に資するのではないかと思います。また、その場合輪止めにタイヤに接触させて設置すると、荷を降ろすときは問題ありませんが、荷を積むときは荷台が沈むため輪止めが外せなくなり、指1本分の間隙を空けて設置することが必要になります。

私はコンビナートにいたときに言われたのですが、静電気が発生するので作業服は基本的に化繊はダメということでした。しかし役所の場合は化繊しかなかったものですから、中に入るときは静電気を体から逃がすようにしていました。鋳物工場では湯が飛んできますが、化繊作業服だと湯が皮膚まで浸透して火傷します。綿製品であれば中まで浸透せず、払いのければ火傷はしません。こういうことは現場で初めておぼえられることです。安衛則には定められていません。

四アルキル鉛は本来は透明なのですが、こぼれた場合にわかるようにガソリンと同じように着色しています。そして、作業者は全身白の防護服・保護具を着用し、床、壁、天井もすべて白色にして、一滴こぼれても判別できるようにします。白色にすることは規則には何ら記載されていませんが、現実には作業場は真っ白で、そういう管理をしていることは現場に行ってみないと分かりません。

ボイラーの免許をお持ちの方はご存知かと思いますが、ボイラーの水面計のハンドル（コック）は、水面計を取り外すときに管軸に対して直角（下向き）にしなければなりません。これを水平にしていると、何か物が当たった場合に下を向いてしまい、水面計が作動しなくなるからです。現場ではこのような本質安全対策への感覚が養われてくると思います。

三柴 今のお話の中で玉掛けの話と、ボイラーのコックの件について、もう少し詳しくご説明いただけますか。

玉泉 玉掛けをするときには、介錯ロープをつけることになります。それによって、クレーンを移動させたときに荷が回転したりしないようにするのが介錯ロープです。その端っこ（※下図赤丸部分）を団子にしていると、荷をつり上げたときに材料に引っかかるなどして材料が跳ねたり、あるいは引っかかることによって荷が揺れて落下する危険があります。なので、介錯ロープの端部は絶対に団子にはいけません。こういうことは規則のどこにも書かれてはいません。経験則から出ているルールなので、現場で事故例を知って経験を積まないと分かりません。

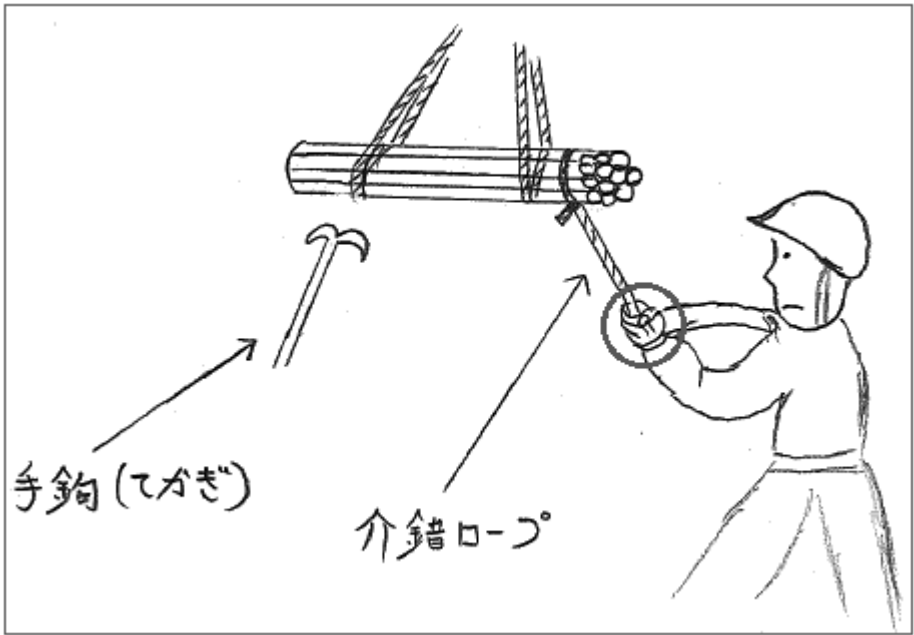

ボイラーの水面計についてですが、下の図の左端が通常の状態、右側についている細い管が水面計です。「蒸気コック」と「水コック」が下を向いていますが、この状態で水面計に対して蒸気も水も生きています。真ん中の図のように、蒸気コックを水平にすると止まります。ともかく蒸気コックか水コックのどちらかを水平にすると、水面計は作動しなくなります。通常は、配管に平行になっていると通じている状態で、90度の角度になると止まります。ところが、ボイラーの場合は下に向いていると通じている状態なのです。コックを水平にしていると、上から物が当たった場合、あるいはコックがいかれてしまった場合に下に下がってしまいます。片方が止まると水面計は作動しなくなりますので、まだ水があると誤認してそれが爆発事故の原因になりかねません。コックの方向が本質的な安全対策代わりになっているわけです。

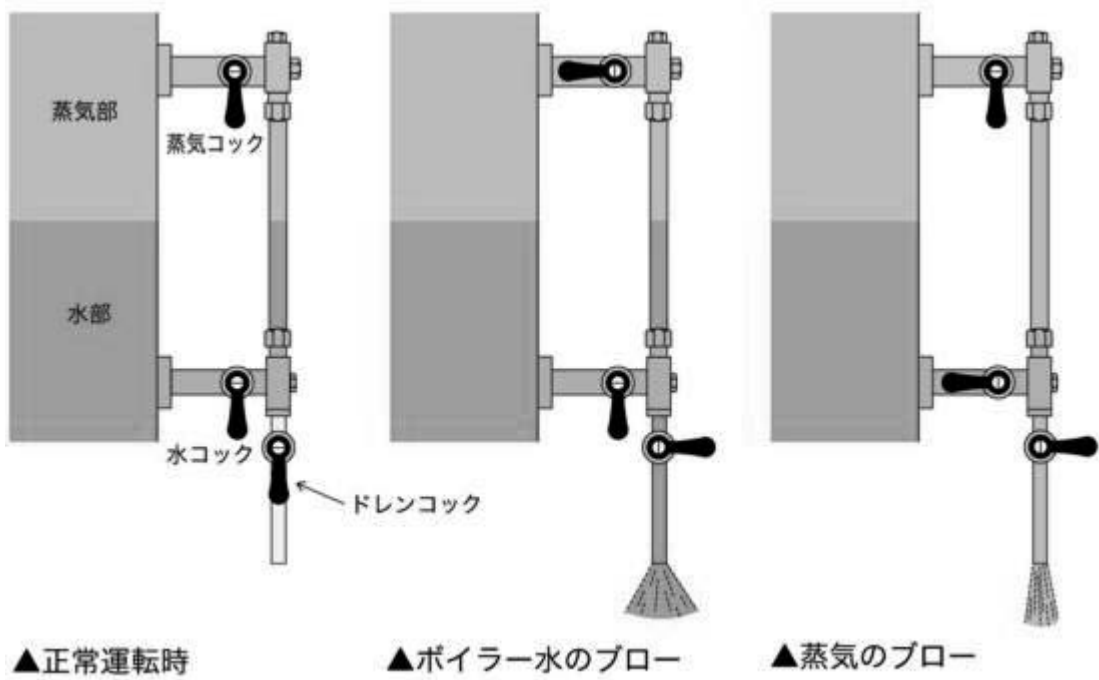

家庭で使用する台所の蛇口は、昔はコックを下に下げたら水が出て上に上げたら水が止まる仕組みになっているものがありました。使う人が分かりやすいようにするためです。しかし、阪神大震災のときに上から物が落ちてきて水がどんどん出てしまっていて、消火活動に影響が出てしまったため、平成9年のJISによって台所のコックは上に上げたら水が出て、下に下げたら止まるという規格がつけられました。ボイラーのコックと同様、これも本質安全対策の考え方に基づくものです。

三柴 なるほど。下に向けるか横に向けるかは、それぞれの状況に応じて安全サイドが決まってくるということですね。

玉泉 その通りです。配管にコックがある場合にも、下に向けて液体やガスを排出するのは誤りで、逆でなければなりません。うっかりコックを下げてしまってガスや液体が出る仕組みだと危険なので、コックは上に向けると出る仕組みにしないとイケません。この点についても知っていれば指導ができます。

三柴 今のお話の「生きている」状態というのは、通じている状態ですね。

玉泉 そうです。

三柴 ボイラーの場合には、垂直の状態を生きている状態にした方が安全だという設計なわけですね。

玉泉 その通りです。

玉泉資料4頁に戻りますが、2年前にインドに行った際に、スローダウンする理由を尋ねてみたところ、そこに小学校がありました。インドの小学校の周囲に道路には全てハンプ（バンプ）が設置されていて、日本でも未だ実施されていないようなことを、インドは既に実現していました。海外では高速道路の出入り口に、スローダウンさせるためにだいたい設置されています。日本でも大きなホテルの入口にはある場合もありますが、交通安全のために日本でもこういう試みは可能ではないかと思います。小学校の通学路に地域の人たちの協力で置いてもらうだけでも、かなり効果的なのではないかと思います。安全の講習ではいつもも言っているのですが、なかなか実現してくれる人はいません。

次に「4. 他の行政機関、同業種などから情報収集、情報共有」、これも非常に重要だと思います。私が見ているのは、厚生労働省（職場の安全サイト）、中災防の事故事例集ほか、製品評価技術基盤機構（製品安全など）、消防庁（事故事例：事故統計資料など）、科学技術振興機構（JST）、人口動態調査（不慮の事故）・・・毎年3万数千人が亡くなっていますが、階段の事故や転倒事故などの事故例が掲載されていますので、勉強になります。また、外国の規則（米国など）も参考になります。梯子一つ例にとっても、日本の安全規則と外国の安全規則とでは内容が異なり、外国の方が規制が厳しいです。そういったところから考え方の違いが分かり、勉強になります。スーパーゼネコン5社は、死亡重大災害の事例の情報を共有していて、同じ事故を二度と起こさないようにしています。現在実施しているかどうかわかりませんが、造船工業会では、お互いに他社の工場の安全パトロールを相互乗り入れで実施して、安全衛生のレベルアップを図っていました。

次に、「5. 現場の安全・衛生管理者、職長等から現場での問題点を直接聞くこと」。相手はプロで、当

初私はアマチュアでしたから、ともかく何でも質問することです。聞けば聞くほど勉強になりますので、同じプレス機械のことでも会社が違えば、知らないふりをして一から聞く。そうするとどんどん教えてくれますので、それを通じてリスクを発見することができます。特に現場をパトロールするときは、下記の点に注意します。

- ①作業、設備に適用される法令、通達、ガイドラインなどを担当者に尋ねる（安全衛生知識、法令の知識の確認）
- ②同じ業種の現場、同じ機械設備であっても、事業場が違った場合、これ何？あれ何？何でも尋ねる。何度でも尋ねる。（相手はプロ。）
- ③目の高さを変えて見る。立ち止まってみる。裏側を見る。（案内者の案内通りにはいかない。）
- ④登って（降りて）みる。触ってみる。臭いでみる。やってみさせる。やってみる。使ってみる。（経験しないとわからないことがある。）
- ⑤パトロールは一瞬しか見ていない。前後の作業、関連作業を想像する。

6番目は、「6. 作業手順書、ヒヤリハット報告、安全パトロール結果、SDSなどを読む」。作業手順書（SOP）には、職長など現場のプロによって作業手順のそばに危険のポイントが書かれているので、プロがどういう見方をするのか非常に勉強になります。

「7. 労災保険の療養補償給付請求書（5号）を読む」。これは監督署の内部の者しか目にするものではないのですが、ここには安衛則にない事故・災害がたくさん出てきますので、これも非常に勉強になります。たとえば針刺し事故については法令上の規定はありません（米国では針刺し事故防止法があります。）。しかし、それが原因で肝炎や癌になる場合もあります。見て初めてこのような事故があるのだということを知りました。あるいは、蜂刺され事故も年間平均18人ほど死者を出していますが、そこからアナフィラキシーショック、エピペン（注射薬）を知ることができ林業作業や建設業、造園業への指導ができます。また、学校の保健師にも指導しましたし、幼稚園、保育園、小学校の先生が遠足で山に行くときに必要な薬を持っていくよう指導したりしています。ドアを開けた際にドアの外側にいた人に当たって負傷をさせる事故、廊下の角を曲がったときに出合い頭で衝突する事故もあります。ドアにスリットを入れたり、曲がり角にミラーを設置したりすることが指導できます。階段の場合、建築基準法では3.5m以上であれば真ん中に手すりが必要とされますが、実は壁側には手すりは必要ありません。しかし実際は転落事故が年間650件前後発生し、労災も非常に多いです。建築基準法上は必要ありませんが、法律だけ遵守していても事故は起きますので、壁側にも手すりを設置するよう指導することができます。そういった小さな事故を知ること重要であり、リスクを発見する目を養う貴重な資料となります。

最後に「8. 労働組合からの意見聴取」ですが、かつて私が監督官に着任したころは、使用者のいないところで労働組合の役員と会いなさいと言われ、会った時の状況を復命書に記載せよと言われました。現在その事業場で何が問題になっているか、人事労務や安全衛生について書記長や委員長から使用者には内緒で話を聴いて、どのような危険があるか、表に出てこない問題や職場から不満が出ている話もありますので、そういう話も聴くことによって、現場を見る際の見落とし防止につなげることができます。現在このようなことは実施していないようですが、ぜひやるべきだと思います。

少々長くなりましたが、以上です。

三柴 ありがとうございます。現場経験に即した非常に参考になる情報提供をいただいたと思います。



先生方からご意見・ご質問ございましたらお願いいたします。

原 大変貴重なご報告ありがとうございました。玉泉資料1頁の安衛則第101条第2項の件ですが、「およそ回転する機械の突出物には巻き込まれるリスクがある」という点については、十分想像できイメージも伝わってきますが、「その観点から留め具だけではなく水平展開できます」とあります。この場合の「水平展開」とはどのような意味でしょうか。

玉泉 「回転軸、歯車、プーリー、フライホイール」だけではなく、回転している部分については水平展開できる・・・たとえば、高速カッターすなわちグラインダーのフランジの部分には、構造規格によってカバーを装着しなければならないとされています。ところが、手持ちのグラインダー、ベビーサンダーの場合にはそのようなルールはなく、構造規格上カバーを必要としません。ただ、巻き込まれるリスクがあることには変わりありません。たとえば、首に手ぬぐいを巻いていたり、腰手ぬぐいの状態では、巻き込まれる危険性があります。あるいは、作業服の袖口のボタンがとまっていない場合もそうです。また、髪の毛の長い人も巻き込まれるリスクがあります。以前、髪の毛の長い人がフライホイールに巻き込まれ、頭皮が半分はぎ取られた事故を見ています。とにかく回転するものは危ない、安衛則等に違反していなくても危ないものは危ないので、経験することによりあるいは規則を展開することによって指導ができると思います。高速カッターの場合、フライホイールの留め具のところをカバーするような構造規格になっていますが、ベビーサンダーはそうになっていません。

原 たしか、黒い円盤のようなものが回転して、火花を散らしながら金属を切断する道具でしたね。

玉泉 そうです。あれは高速カッターで、一種のグラインダーです。

原 安衛法には一応違反しないけれども、非常に危険でリスクがある・・・

玉泉 そうです。高速カッターはフライホイールの留め具にカバーをしなければなりません。しかし、ベビーサンダーは手で持って使う小型のグラインダーですが、フライホイールのカバーが不要です。そういう場合は、手ぬぐいや袖口をきちんと整えなさいということになります。

（※インターネットの画像により両者の相違および留め具のカバー等について解説）

原 ありがとうございました。

三柴 他によろしいでしょうか。では私の方からお尋ねしたいのですが、まず酸欠則についてのご説明を今一度お願いできますか。

玉泉 トンネルに入る際に、入場と退場をする人員を点検しなければならないことになっています。入場したのが10人で、出てきたのが9人となると、あと一人は誰だかわかりません。そのため、氏名を記載して入退場を確認しなければなりません。ですから正確には、人員の点検というよりも、誰が入って誰

が出てきたかを確認することが重要なのです。もし2人トンネル内に残っているとすると誰と誰なのか、全員を招集しなければ確認できませんし、帰宅してしまったら確かめようもありません。なので、名札を裏表にするなどといった方法をとるわけです。

三柴 要するに、トンネル内で倒れているかもしれない人を特定しなければならないということですね。

玉泉 そうです。大体どこでもやっていると思いますが、酸欠の危険性のある場所に入るときには、人員の点検は名札方式をとります。単に人数を点検するのではなく、名札を掲示して入退場者一人一人を特定しなければリスク管理としては緩いわけです。

三柴 ありがとうございます。次にルールの話になりますが、玉泉先生のお話を前提にすると、なるべく多くのことをガイドラインよりも規則に明記して分かりやすく、なおかつ強制力を持たせたほうが現場にとってもよろしいのではないかという趣旨に聞こえたのですがいかがでしょうか。

玉泉 その通りです。ガイドラインでは少々効き目が弱いと思います。構造規格は法律そのものなので、違反すれば安衛法第42条違反が成立します。

三柴 この点畠中先生、唐沢先生は立法者として、どの辺りで強制力のあるルールとガイドラインとの区分けをしているか、何かコメントいただけないでしょうか。

唐沢 私もいくつかの規則の制定や改正を手がけたことがあります。やはりいろいろな業種にまたがって同様のことが起こり得るような事案については、規則化した方がベターだと思いながら仕事に取り組んでいました。非常に特殊な分野であり発生頻度も多くないようなものについては、必ずしも規則化の必要はなく、ガイドラインや通達の中に取り込むことで足りるだろうと解していました。

三柴 ありがとうございます。リスクの重篤さや確実性よりも、ヨコ展開の広がりを指標にされていたということですね。

唐沢 言葉足りませんでしたが、重篤なリスクが考えられるものについても、規則化がよろしいかと思っていました。

三柴 ありがとうございます。畠中先生、お願いします。

畠中 やはり事案の重篤性、事例数の多さ、そういうものが重要視されると思うのですが、もう一つ、現行の安衛衛生関係法令は告示まで含めると約3500カ条あります。やはり規制の方策一つとっても、色々な角度からアプローチする機会が多いのです。その場合にある特定のアプローチだけについて罰則を背景とした基準を作って固定してしまうと、まさに安全技術の発展を阻害しかねません。その辺り色々な要素を考慮しながら規則が作られていくのだろうと思います。

三柴 ありがとうございます。次にもう一つルール論になりますが、本法や定義規定を定めた政令等に書くべきものと、規則に書くべきものとの区分けについてです。基本的には本法は一般原則や通則的なものを書き、また強制性も含んでいると思います。そして規則によって個別的・具体的なルールを定めていくという区分けをしていると思います。その分本法は一読しただけでは分かりにくいという性格も出てきてしまうと思います。前の厚労科研のプロジェクトで金原先生においでいただいたときに、安衛法のさらに上に要綱のようなものをつくって、そこには本当に必要な一般原則を使用者や経営団体との調整など踏まえ、きっちりと書いた方がいいというご意見をうかがいました。どこまで法律に書いてどこから規則にするか、玉泉先生、ご意見ありましたらお願いできますか。

玉泉 金原先生のご意見の詳細は存じませんが、命にかかわる問題は法律上罰則を背景にしなければならぬと思います。その点VDT作業などはかなり障害も出ているし、熱中症に関しては水と塩を与えないという趣旨の規則しかありません。これほど多くの事故があるにもかかわらず、法制化されていない部分が多々あるのではないかとことです。やはり、命に直接危険のあるものは法制化しないとダメだろうと思います。現場からすればあれもこれも法制化すべきではないかという問題は多々あるのですが、それを言い出したらキリがないので、どこかで折り合いをつけているのではないのでしょうか。

三柴 金原先生が仰っていた要綱は、リスクを生み出す者あるいはリスクを管理できる者が管理責任を負うべきであるとする原則は、イギリスであればH SWAの第3条に定められているところ、日本では産業利益との調整も必要なため、正面から書くことはできません。しかし、そのような方向に向けて法整備を進めているという経過はあります。最近であれば運輸業で、初荷主の仕事の頼み方について政策上のメッセージを出すことをしているのもその流れといえます。正面からかけなかったものは、まず要綱から書いて、本来なすべきことをそこで示してみてもどうかということです。

玉泉 理念規定ということですね。

三柴 まさにその通りで、理念規定をどうするかという問題です。

玉泉 運送業もそうですし、石綿についても法改正がなされ、発注者の責任が重くなりましたが、発注者の責任については安衛法では書ききれていないと思います。その点の重要性については、金原先生のご指摘の通りだと思います。

三柴 本法と規則との棲み分けについては、畠中先生、唐沢先生、何かご意見ありますでしょうか。

畠中 私は、今の安衛法には必要なことはほとんど規定されているという感じを持っております。たとえば安衛法第20条から24条までの規定は第27条で命令委任がなされていますが、これらの規定によっていわゆる使用従属関係に着目して事業者に義務付けることは全て書ける建前になっていると思います。そうすると、安衛法の他の条文、たとえば作業主任者や作業環境測定に関する規定はどうなんだと

いかもかもしれませんが、それはハッキリ言って第20条から第24条に基づく厚生労働省でも書けるものを、さらにそれを特化するという形で法律条文になっていると、そういう理解をすべきではないかと思います。そして、使用従属関係に着目した規制では不十分、あるいはそれ以外の義務主体を名宛人とした方がより効果的に労働者の命や健康を保護できるという点については、安衛法の中で別の義務主体が立てられているわけです。製造流通規制や請負規制、リース規制などがそれで、さらに、安衛法以外では派遣規制において義務主体の特例が定められています。使用従属関係に着目した規制を主体としながら、一方で先ほどの玉泉先生のお話にあったような発注者規制についても、完璧な形ではないにせよ請負規制ということで安衛法の中で規制がなされています。ちなみに、使用従属関係に着目した規制は、大きく以下の4つに分かれると思います。すなわち、安衛衛生管理体制、危害防止措置、健康管理、そして安衛法のもう一つの目的である快適な作業環境の形成です。

三柴 ありがとうございます。原さんの分担報告書の中で、確かに法第20条以下の危害防止基準の中核規定は、重要な内容が書かれていて、工場法時代から受け継がれた大事な条文でありながら、その後リスク内容の変容もあって、規則の内容なども踏まえて法律本法も現状に合ったリスクの内容を列挙してもいいのではないかと、よく練られた条文ではあるけれども時代への適応性を踏まえてもいいのではないかとこの意見がありました。この点についてはいかがでしょうか。

畠中 私は第20条から第27条までが安衛法の基本中の基本だと思うのですが、その中でも第25条と第25条の2を外してお話ししていましたが、この2つの条文は第20条から第24条までとは少々性格が違うんです。そのため、第20条から第27条の間から取り外して隣に置いた方が分かりやすい気がします。要するに、第20条から第24条までの規定によって、使用従属関係に着目した規制は、第27条に基づく厚生労働省令によってすべて書けると思います。

三柴 別扱いすべきは第25条と第25条の2ということですね。

畠中 第25条は緊急時の事業者の退避させる義務の規定です。この規定は安衛法の制定以前は労基法に基づく各省令によって定められていました。それが安衛法の制定に際して、国会の修正によって法律事項に格上げされたわけです。つまり、省令で書ける内容を法律化した規定です。

三柴 いずれにせよ第20条から第24条によって、時代がある程度変わったとしても対応できるように書かれているということですね。

畠中 そういうことです。

三柴 唐沢先生、いかがでしょうか。

唐沢 たとえば安衛法第57条の2、3、4などは、昭和51、2年当時の諸般の事情に鑑みて、化学物質の有害性調査制度を別個に法律事項として起こしたわけですから、原先生の主張されている内容で、



より具体的に重要な問題で法律事項で規定した方が世の中に法規範として定着するものが存在するのであれば、法律事項として定めるといえることはあり得ると思います。

三柴 ありがとうございます。他にいかがでしょうか。

高木 先ほど法規で入れるかガイドラインで入れるかという議論があったところですが、今後の新しいリスクとして、労働者の高齢化に伴って高齢者の心身機能低下によるリスクが増えてくると思います。これを受けて令和2年3月に厚労省がエイジフレンドリーガイドラインを定め、現在動き出していると思います。玉泉先生にお伺いしたいのですが、高齢者が加害者となる、すなわち心身機能低下が著しいにも関わらず現場で働いていたがゆえに災害を起こすというケースに対して、事業者の責任をもっと明確にすべきかどうか、その点についてどのようにお考えでしょうか。

玉泉 高齢者だから云々ということは一切考えていません。

高木 現在大阪の公共工事の発注者から相談を受けていますが、60代70代ならまだしも建設現場では80代の人でも働いていて、その人は明らかに身体機能が低下していて事故が起きている。こうしたことに対してもう少し事業者規制をかけた方がいいのではないかと発注者からの相談を受けました。そういう時代になってくるのではないかと思います、いかがでしょうか。

玉泉 高齢者は現実に働いていますが、身体機能や加齢による影響は人によって違いがあるので、年齢で一律に規制内容を決めるのはなかなか難しいと思います。そうすると、何をもって就業制限できるのか、一筋縄ではいかないでしょう。個人的にはどこで線引きすべきなのか判断に迷うところです。安全パトロールのために建設現場に足を運ぶと、高齢者は働いていますが、事業者はそれこそ手元作業しかさせていません。高所作業もさせていないし、そこで事故が起きようものなら安全配慮義務違反の責任を問われますから、実際には手元作業程度しかさせていないわけです。ゼネコンなどは70歳に達した労働者は現場に一切入れていないと思います。私はそのような措置はおかしいと思っています。70歳になっても元気な人はいますから、一概にダメとは言えないと思います。作業の内容について安全配慮義務の観点から事業者が配慮する、これについては職長教育における適正配置という項目があり、その中で言われています。その人の年齢や技能にあった適正配置をすべきであると言っていますので、現実にはそうしています。だからといって一律に禁止するというのも難しいと思います。

高木 今仰ったことは本当に正しいと思います。昨年の3月に厚労省でエイジフレンドリーガイドラインが出て、そこで新しい視点として高年齢者の年齢ではかるのではなく、高年齢者それぞれが持つ体力と健康の状況を事業者が把握し、それに応じた対応をすべきであると定められています。しかし現在、日本全国大企業を含め、そのような個々人の体力と健康の状況を把握しながら適正配置を行っているところはあまり見受けられません。しかし、こうしたガイドラインが示されたことによって、今後はガイドラインのような措置が事業者に求められてくるのではないかと思います。個々人の体力の状況を把握してそれに応じた対策を講じるといったような・・・

玉泉 それはその通りだと思います。建設業は職長教育の項目に入っているし、現場では高齢者の安全管理には配慮していると思います。製造業では80代90代はあまりいないので、現実には使用者が体力などを勘案して適正配置をしているように思われます。それほど無茶はさせていない気がします。ただ、歳とってくると1センチの段差でも転倒する場合がありますので、照明をつける、段差表示をするといった細かい点を現場では口を酸っぱくして言っています。ガイドラインにも書いてあると思います。そういう対策を事業者としては、安全配慮義務の観点からより一層講じなければならないものと思っています。

高木 ありがとうございます。

森 今の点ですが、産業医の立場からすると興味深い議論です。過去そして現在もそうだと思いますが、北欧では消防士の適性検査では一定の運動させても心電図異常がないこと等といった要件が課されていますが、高齢者の問題というよりも作業と高齢者との組み合わせの問題になってくると思います。そうすると、作業ごとに当該作業に必要な体力の要件をきちっと定めないと、結局全部制限をしてしまう結果になってしまうことと思います。たとえば、突然倒れる危険があったとしても、倒れたときに何が起きるかという点まで全部評価した上で判断する必要があると思います。なので、一般健診から始まる現行の取組みでは非常に厳しいかと思いますが、今の議論を聴いていて、やり方を変えなくてはならないと感じました。

高木 貴重なご意見をありがとうございます。今一番問題なのは、ドラグショベルのような車両系建設機械の運転手の高齢化で、一般車両の高齢ドライバーの免許返納問題と類似した問題が、建設現場や製造現場あるいは鉱山の現場で高齢のオペレーターが加害者となる事故という形でクローズアップされるのではないかと思います。

三柴 高齢者への政策の焦点化については、私もドライブをかけた一人ではあるのですが、法規制というものは関係者をあまり刺激しすぎると、そもそも法案として通らないことがあります。なので、“エレガントに”定めなければならない場合もあります。イギリスでは、“do able work”という概念が産業保健から生まれてきていまして、出来る仕事をさせるのも事業者の責任だという考え方です。日本の場合は産業保健の施策ということで、健康管理の枠組みの中で個別に配慮も行うという形です。あるいは、安衛法第62条にあるように、中高年齢者や障害者の適正配置をするよう努めるといった書き方をしてきました。森先生からご指摘がありましたように、体力の要件等着目するポイントを変えていかないと、今の枠組みだけでは上手くいかないのではないかと思います。

それでは、玉泉先生のご報告はここまでということで、いったん休憩としたうえで、藤森先生から特別衛生規則について経過報告という趣旨でお話ししたいと思います。

三柴 それでは再開させていただきます。まずは藤森先生から特別衛生規則について調査の途中経過をご報告いただくこととなります。では藤森先生、よろしくお願いいたします。

藤森 藤森でございます。私も現場で監督官を務めておりましたが、玉泉先生ほど経験豊富ではありません。玉泉先生とは京都で1年間現場でご一緒させていただき、色々のご指導いただきました。先ほど玉泉先生のご報告の中で、「広く深く」というお話がありましたが、私の方は広く浅くといった感じで、監督官のほか労災補償関係での訴訟対応、内閣法制局で法令や条約関連の仕事に携わり、また中央労働委員会で不当労働行為の審査や和解の業務に従事しました。また、産業医学振興財団で産業医の方々の認定研修の企画・運営なども担当しておりました。その後中災防に移り、現在は東京安全衛生教育センターで事業場の安全衛生教育を担当する講師の人たちの研修を担当しています。ちなみにセンターは、現在コロナ禍のために少なくなっていますが、通常は1年間に3200人が訪れます。

それでは、「労働衛生関係の特別規則の趣旨と概要、統合の可能性」ということで、経過報告をさせていただきます。とはいえ、昨年11月以来なかなか進捗せず申し訳なく思っております。一応、50～60頁の資料（※「労働衛生関係の特別規則の趣旨と概要、統合の可能性」、以下「藤森資料」とする）を配布させていただきましたが、未だ検証を要する箇所がありますので、経過報告ということでご了承いただければと思います。

先ず藤森資料1頁にあるように、検討対象となるのはここに列挙した11の特別規則です。これらの規則のいくつかは安衛法以前からありましたが、本稿ではそれを踏まえて昭和47年の安衛法制定を契機とした規則に重点を置こうと考えています。①から⑧までの規則は、昭和47年の安衛法制定と時を同じくして労働省令として施行されています。⑨から⑪については、その後の状況等も踏まえて施行された規則ということです。以前、⑧の事務所衛生基準規則について畠中先生からご示唆をいただきましたが、他の規則と同様昭和47年制定のものでありながら、他の規則と一括りで検討対象とすべきか否かということです。それも踏まえまして、制定の時期は他の規則と同じで、同じ労働省令ということで検討対象に加えました。藤森資料1～2頁に目次を載せましたが、まず「1 労働安全衛生法及び労働安全衛生規則との関係について」では、安衛法と安衛則（特に第3編「衛生基準」との関係、その中でも安衛法と各特別規則との関係、安衛則と各特別規則との関係、この辺りの整理が必要かと考えて検討しました。そして、「2 各特別規則の制定の背景・経緯及びその後の主な改正点について」。次にこれは最後の5にも関連してきますが、「3 各特別規則の基本構造・体系・構成の共通性について」を検討することで、5の切り口になればと思います。4番目は「4 各特別規則における定義・適用の対象・範囲等について」も重要です。大本については政令で定めているものもありますが、規則特有の定義、適用対象・範囲などが業務からみた面、作業からみた面、物質からみた面、場所等からみた面から定められ、そしてその裏返しともいえる適用除外の定めがあります。これは曝露量、消費量、時間、あるいは設備等に関連して定められますが、こうした点も考察したいと思います。そして「5 各特別規則統合の可能性の考察」で「労働衛生の3管理」の観点から、こうした諸規則がどのような規定のされ方をしているのかについても考察するつもりです。

藤森資料2頁「1 安衛法、安衛則及び各特別規則との関係について」ですが、まず前提として、表1を掲載しました。表左欄にて職業性疾病、作業関連疾患、私傷病という分類を行い、それぞれについて個別の疾病を挙げ、それぞれに対する管理のポイントを記載しています。

**表1 疾病の種類と対策の関係**

分類	個別疾病（例）	管理のポイント
職業性疾病 急性疾患	一酸化炭素中毒、酸欠、有機溶剤中毒、熱中症等	作業管理
慢性疾患	金属中毒、じん肺、石綿肺、有機溶剤中毒等	作業環境管理
作業関連疾患 局所 静的 精神的 生活習慣病	情報機器作業による障害、立ち作業(腰痛) 頸肩腕症候群、ストレス関連疾患 高血圧、脳心臓疾患、糖尿病	作業環境管理 作業管理
私傷病	遺伝病等	健康管理

作業環境管理、作業管理、健康管理は「労働衛生の3管理」といわれていますが、一つ具体的な例を挙げると、表1左欄の一番上の「職業性疾病」は急性疾患と慢性疾患に分かれます。そのうち例えば急性疾患の酸欠に対しては、3つの管理のうち作業管理が特に重要だということから、規則も作業内容や作業主任者、監視人や保護具などの規定をその内容としています。

藤森資料3頁にある作業管理ですが、一般的に作業環境管理の補完、すなわち作業環境管理だけでは十分ではない場合にも必要とされるものです。法律における書き方としては安衛法第65条の3のように努力規定になっていて、個別具体的内容は各規則に委ねられています。作業管理については、法律ではどこに書いてあるのかという質問をよく受けることがあります。安衛法第65条の3であり、挿入条文として追加したのには意味があると思います。

「(2) 安衛法と安衛則及び各特別規則との関係について」(藤森資料3頁)ですが、安衛法と安衛則・特別規則は委任関係にあり、「職場に存在する化学的要因、物理的要因等によって発生するおそれがある健康障害を防止するために、労働者に及ぼす健康障害の重要なものを例示的に列挙して」います。条文としては藤森資料4頁に掲載した安衛法第22条がその一例です。同条に書かれている「健康障害を防止するため必要な措置」の「健康障害」が一～四号に例示されています。また、「労働者が就業する建設物その他作業場の構造上の欠陥や作業環境の不適切により作業条件が不良となり、健康、風紀、生命の保持に支障を生じることを防止することを目的として」定められているのが第23条です。そして、先ほどお話があったように、このような法律の条文が第27条によって規則委任がなされています。すなわち、「上記事業者が講ずべき措置について、その具体的内容を厚生労働省令すなわち安衛則及び11の各特別規則で定めることとしている」ということになります。これを図で示すと、藤森資料5頁以下の図1および図2になります。第22条の内容を示した図1の下の方をみると、化学的要因、物理的要因、精神的要因、有害物質の汚染要因など様々な要因があり、その上にある様々な危険を生じさせるおそれがあります。これに対して事業者としては、健康障害防止措置を講じなければならないという仕組みになっています。



図1 設備、原材料等による健康障害防止の措置（法第22条）

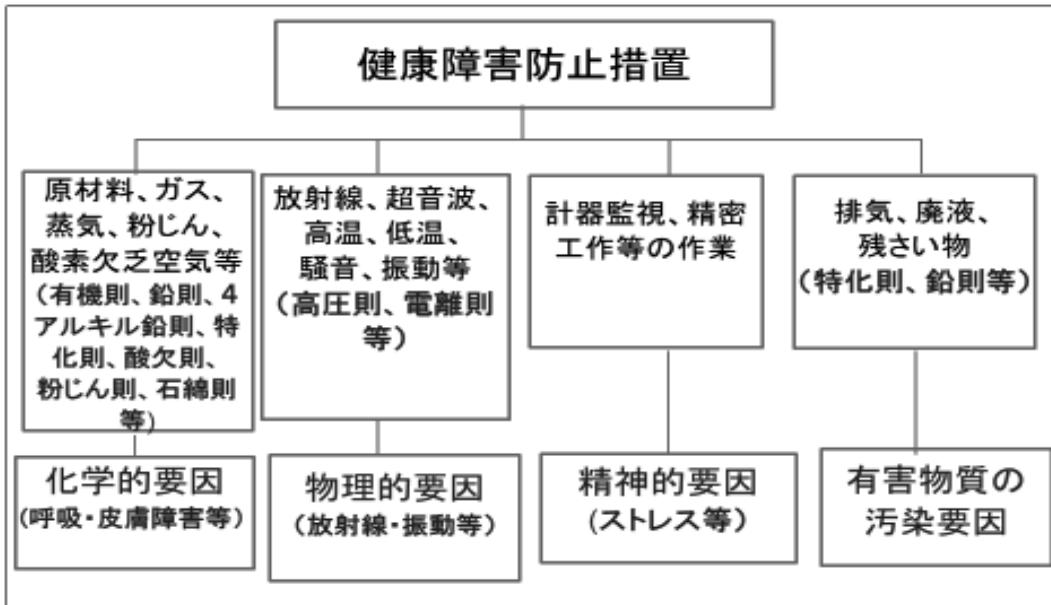

藤森資料6頁の図2は第23条の問題です。欠陥の排除ということで、現場に必要とされる環境整備の措置を講じなければならないということです。

図2 環境整備の措置（法第23条）

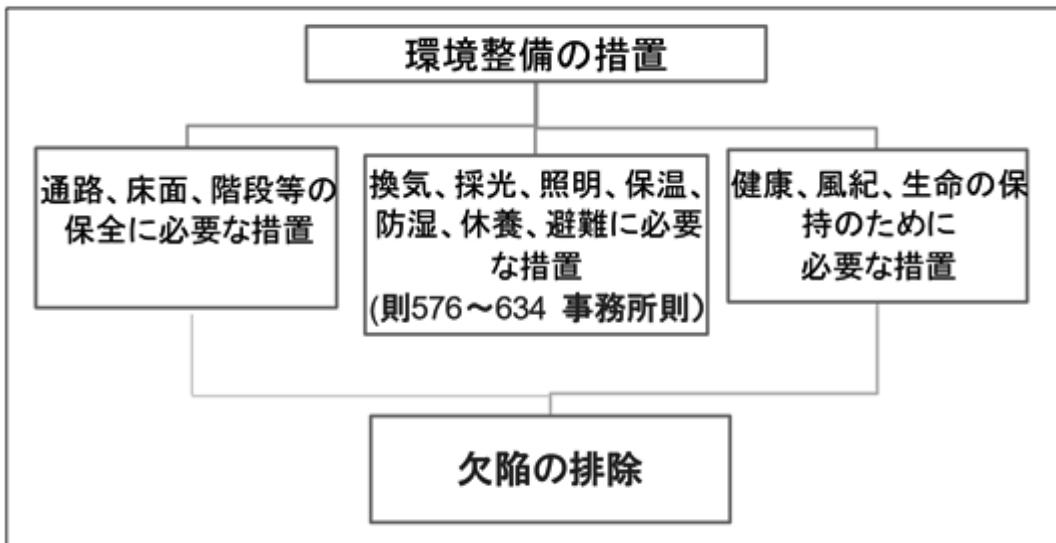

労働安全衛生規則や特別規則は、このように整理できるのではないかと思います。

藤森資料7頁の表2をご覧ください。一般化するのが難しい面があるのもう一度検証し直しますが、現場において、人、モノ、作業、管理という観点から主なものは各規則等でこのように分類・規定されているといったことを一つの表にまとめたもので、概ねこのような分類ができるだろうということです。

表2 各規則において共通する「事業者が講ずべき措置」（主なもの）

	有機 則	鉛 則	4 アル 則	特 化 則	高 圧 則	電 離 則	酸 欠 則	事 務 所 則	粉 じん 則	石 綿 則	除 染 則
設 備	○	○	○	○					○	○	
管 理 (作業主任者)	○	○	○	○	○	○	○			○	
(特別教育)			○	○	○	○	○		○	○	○
(定期自主検査)	○			○		○			○	○	
測 定	○	○		○			○	○	○		○
健 康 診 断	○	○	○	○	○				○	○	○
保 護 具	○		○	○			○		○	○	○

なかなか複雑な問題になりますが、藤森資料7頁の「(2) 安衛則と各特別規則との関係」です。安衛則は全部で678カ条、改正による挿入条文を含めるとさらに多くなりますが、そのうちのほとんどが安全基準に関する規定です。第3編に「衛生基準」として関連条文が置かれています。そして藤森資料7頁に記載したとおり、「安衛則第3編「衛生基準」において、有害環境等による労働者の健康障害を防止することを主眼とするものと労働者を就業させる建設物その他の作業場における健康、風紀及び生命の保持のための措置に関するものが定められているが、11の特別規則が適用される事項については、特別規定である各特別規則の規定が優先し、一般規定である安衛則第3編の規定は適用されない」という関係にあります。たとえば第3編冒頭にある第576条に規定する「ガス、蒸気又は粉じん」は、各特別規定の適用がないものをいいます。粉じん則などで規定のあるものについては粉じん則が優先するわけです。そういう特別規則の規定でカバーされないものについては、安衛則が適用されます。各特別規則の適用がある物質についてはそれぞれ各特別規則に定める設備を設ける等の措置を講じる必要があります。保護具についても、安衛則第593条以下に規定がありますが、各特別規則において必要とされる保護具については各特別規則の定めるところによることになり、安衛則の規定は、当該各特別規則の定め適用を受けない業務について適用されることとなります。このように安衛則と特別規則は、一般法と特別法の関係にあります。

安衛則の他の条文として、藤森資料2頁・表1にある作業関連疾患の個別の疾病例として、情報機器作業による障害（改正前はVDT作業）、立ち作業（腰痛）、頸肩腕症候群、ほかに場合によっては脳心臓疾患なども作業関連疾患としてあり得ます。こうした作業関連疾患は一般的には二つのカテゴリーに分けられ、一つは何らかの形で業務との関連性があるもの、すなわち職業性疾患ほど業務と疾病との因果関係が明らかではないのですが、何らかの形で業務に関連があるもの、もう一つは元々私病的なものであったものが業務によって増悪するものが作業関連疾患に含まれます。そういったもののほか、加齢に伴うもの、騒音、日常生活の振動、そういったものについては特別規則に規定がありません。そういう範疇のものについては安衛則第3編の中で規定しているということです。また、通達や対策要綱あるいは指針という形でこういう疾病や防止措置について規定しています。したがって、これらについては最後に

検討するところですが、どこまで規則レベルに規定できるかという点についても、課題の一つではないかと思えます。

7頁には大きな赤字で「未完」と記載していますが、安衛則は特別規則に規定がないものを適用対象とするところ、ダイオキシンなどは第3編の第592条の2以下に、平成13年に新たに追加改正となりました。もともとダイオキシンは使用目的で生成されたものではなく、招かれざる客という類の物質です。ダイオキシン関係の規則は6つの条文から成り立っていますが、一つの特別規則を作るには至らず、安衛則第3編の第1章の2として盛り込まれています。安衛則にはそのような性質もあるのかもしれませんが。以上のような安衛則と各特別規則との関係は、今一度整理・検証してみたいと思えます。

総論部分については以上のとおりですが、これに基づいて藤森資料8頁以降に各特別規則の制定の背景、経緯およびその後の改正点、基本構造、共通性、定義、適用除外の問題等のあらましを記述しました。

たとえば有機溶剤については、9頁の「2 構成」において全体像を俯瞰すべく有機則各章の概要を記載しました。「第4章 管理(第19条～第27条)」ですが、作業主任者、点検、保守など作業管理に関連する規定で構成されています。「第8章 有機溶剤の貯蔵及びから容器の処理(第35条、第36条)」および「第9章 有機溶剤作業主任者技能講習(第37条)」は別立ての章になっていますが、管理という捉え方で受け手がわかるのかという疑問があります。あるいは、第8章も一緒にして「管理」とすべきであるのか、この辺りも最後の方で検討するつもりです。有機溶剤に関しては、最近では9頁「⑤ 平成26年8月25日(厚生労働省令第101号)による改正」によって、10種類の物質が特別有機溶剤として特定化学物質障害予防規則(第2類・特別管理物質)の規制対象物質となった経緯が挙げられます。

藤森資料10頁に移りますが、有機則は「対象業務」を行う場合に適用されます。先ほども申しました適用対象、適用範囲、その裏返しである適用除外とは何を指しているかですが、有機則は12の「業務」をとらえて必要な措置を義務付けています。概要は10頁、図2に示しました。

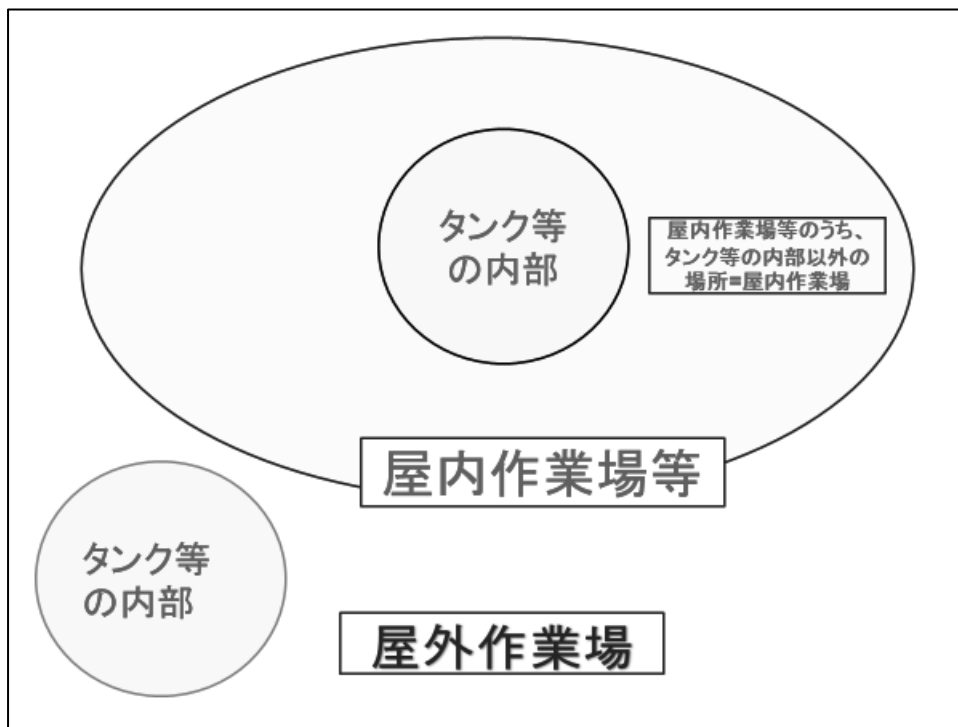

規定の仕方が、「タンク等の内部」あるいは「タンク等の内部以外」などとされていて、条文だけ読ん

でも理解が難しい局面があるため、このような図にしました。条文はなるべく分かりやすく越したことはありません。

藤森資料1 1頁では、玉泉先生はじめ現場の監督官の方にぜひ実態をお尋ねしたいところですが、適用除外や特例について記述しています。実際に適用除外になるのか、どのような判断をするのか、私も現場では苦労したところです。鉛則においても適用除外の問題があり（藤森資料1 6頁）、一部の適用除外、全部の適用除外など各規則全てに共通ところですが、その辺りの整理が難しいところですが、なるべく分かりやすく解説したいと考えています。

藤森資料2 2頁では特化則すなわち特定化学物質障害予防規則を取り上げています。昭和47年につくられた規則で、規制対象となる物質が多く現在75種に及びます。その経緯を22～23頁に記載しましたが、最近では「③ 平成17年2月24日(厚生労働省令第21号)による改正」により、石綿（アスベスト）が特定化学物質等障害予防規則から分離独立して「石綿障害予防規則」（平成17年厚生労働省令第21号）とされたことに伴い、関係規定を改めたこと、あるいは「⑥ 平成26年8月25日(厚生労働省令第101号)による改正」により、有機則における12種類の物質を職業がんの原因となる可能性があることを踏まえて、新たに「特別有機溶剤」として第2類物質として追加し、所要の改正を行ったことなどが挙げられます。作業主任者については、有機溶剤作業主任者技能講習を受講した人がこれを務めるということになっています。直近では、「⑨ 令和2年4月22日(厚生労働省令第89号)による改正」により、塩基性酸化マンガンに神経機能障害発症の危険性が確認されたことから、これを第2類特定化学物質(管理第2類物質)として追加し、また神経機能障害及び肺がんの発症の危険性が確認された溶接ヒュームを第2類物質に加え、溶接ヒュームを発生させる金属アーク溶接等作業に係る措置を定めました。なお、アーク溶接のように作業を横断的に捉えると、その関連災害、爆発火災、火傷、場合によっては墜落など安衛則に規定があり、衛生については粉じん、可視光線、有害光線等の問題が挙げられますので、なかなか難しいところかもしれませんが、先ほどの作業関連疾患も含め作業によって一つの共通の規則ができないものかと考えています。

藤森資料2 6～27頁には特別有機溶剤に関する規制を図示しました。特化則の規制対象物質は75種類あり、それに対する規制や措置内容も多岐にわたっています。この他に引き続き藤森資料にて、高压則、電離則などに触れています。37頁では酸欠則を扱っていきまして、これも安衛法以前からの経緯を追ってみると、先人の努力を肌で感じます。37頁、7-1の10行目あたりでしょうか。今でもなかなか労使の間に酸欠に関する認識が高まっていないようですが、当時もそうでした。たまたま今週、東京安全衛生教育センターで、インストラクターになる方のための酸欠に関する講習が3日間行われましたが、一般的には未だ酸欠については他の問題に比べて、目に見えず分かりにくいせいもあり、認識は高くないという感じを受けました。酸欠による職業性疾病は急性という性質が顕著ですから、特に作業管理が必要になります。なので、作業管理を基礎とする仕組みになっています。酸欠則の沿革を調べてみると、バナナ熟成加工作業中の死亡災害などが相次いで発生していたところ、当初は単なるガス中毒であると誤認されるか、あるいは正体不明の疾病であると認識されていました。これに対して当時の労働局が取り組んだ経緯もあり、それを引用しています。この点唐沢先生から補足していただくと幸いです。酸欠則の切り口は先ほども申しました通り、急性という特質ゆえに作業管理になるわけですが、藤森資料3 8頁の「2 構成」をみると、「第2章 一般的防止措置(第3条～第17条)」という章があり、主としてここに作業管理の観点から一般的な防止措置が定められています。そして「第3章 特殊な作業におけ



る防止措置(第18条～第25条の2)」として、ボーリング作業や冷蔵室内作業など具体的な作業についてそれぞれ講ずべき措置が規定されています。酸欠則はこのように、他の規則と異なり、作業を一つの切り口として具体的なものを挙げ、それらに対する具体的な防止措置を定めるもので、こういう規制の仕方のできるのかと思います。この点はまた最後の方で関連することです。藤森資料41頁の「(2) 特殊な作業における防止措置」にその内容を書いています。一般的防止措置に加えて、圧気工法による作業、特定の地層に通じる井戸等が設けられている地下室等における作業、し尿等を入れてある設備等の改造等の作業等特殊な作業又は冷蔵室等特殊な施設において発生する酸素欠乏症等（硫化水素なども含むので“等”という書き方をしています）を防止するため必要な措置を、41頁①～⑩に記載したとおり定めています。受けてからしてみれば、措置の内容がより分かりやすく判別しやすいのではないかと思います。他の規則にもこのように具体的に定めることは難しいかもしれませんが、検討する価値はあるかと思います。

事務所則（藤森資料43頁以下）については、これを他の規則と同様に扱うべきかどうか畠中先生からご示唆いただいたところですが、藤森資料に掲載させていただきました。事務所則の適用対象は一般的な事務所やオフィスになりますが、安衛法に基づいて昭和47年に制定されました。事務所則における定義は「事務作業(カードせん孔機、タイプライターその他の事務用機器を使用して行なう作業を含む。)」といったように、古い表現が用いられていますが、こうした概念の整理も今後の課題の一つかと思われます。次いで、粉じん則（藤森資料45頁以下）、石綿則（同51頁以下）にも全体的に言及していますが、検証が不十分なし未完の部分もありますので、ご猶予をお許しいただいたうえで、先生方のご指導を賜ればと思います。

最後の「5 各特別規則統合の可能性」（藤森資料58頁）も「未完」になっていますが、各特別規則統合の可能性について、概ね3点ほど指摘できるかと思います。一つは、分かりやすさです。いろいろな規則が多岐にわたっているので、それぞれについて相応の意味や経緯がありますが、適用漏れがないようにすべきです。三柴先生もご指摘の通り、ルールがあまりにも細かくなると分かりにくくなり、現場でも忌避感が強まるおそれがあります。やはり受け手にとってのアプローチのしやすさを高めるべく、可能な限り体系や共通性を考える必要があるかと思っています。二つには、あるルールが規則レベルのものなのか、あるいは通達や要綱レベルのものなのか、という問題が先ほど指摘されたところですが、衛生関係は作業関連疾患という疾病を個別にみていかなければならない側面があります。特に案外落とし穴となるのは、常々現場でも感じていたことですが、騒音などはあらゆる場面で存在し、また、年齢が35歳位から特に高音域の4000ヘルツあたりの聴力損失がみられるという一般的にも悪くなっていくし、業務によっては余計に悪くなっていきます。しかし個別にみると、騒音の規定は一般法ともいえる安衛則第3編に置かれています。それ以外は、指針や対策要綱で詳細化されています。腰痛に関しても同じで、こういったルールを法規則化することの是非も検討してはどうでしょうか。3番目には、全体的に必要な応じて表現等を見直し整備することも重要です。

雑駁な途中経過の報告ではありますが、以上でございます。

三柴 ありがとうございます。それでは、先生方からご意見・ご質問ありましたらお願いいたします。

私の方から口火を切らせていただきますと、藤森先生のご報告の最後で、それぞれの経緯があって制定された専門性の高い規則も、現場の運用面では分かりやすさが重要である旨お話いただきました。た

たとえばイギリスであれば化学物質対応は法律レベルで定められていますが、日本の場合は歴史的な経緯もあって個別の規則に分散している状況です。あえて統合の可能性を探るとすると、新しいものを作ってしまうべきなのか、それとも現行の規則のどこかにはめ込んでいくべきなのか、その点について何かお考えありますでしょうか。

藤森 ひとつの方法としては、特別有機溶剤として10種の有機溶剤を特化則に移転した例があります。特化則はボリュームがありますが、同規則に括ってしまう方法もあるのではないのでしょうか。

三柴 ありがとうございます。唐沢先生にお尋ねしたいのですが、特化則をつくったとき、少なくとも安衛法制定の際に整備充実化がなされたわけですが、その時点でなぜ有機則と分けてしまったのかということ。もともと特化則をつくった時点で、わずかな物質を対象とした特別衛生規則はありましたが、それ以外の物質でもいろいろ問題が発生しているから特化則がつくられました。しかし、何でも適用対象としたわけではなく、特定のできる物質で障害が発生していたことを踏まえていました。そうすると、特化則をつくった時点でみんな特化則にまとめてしまうことも可能だったのではないかと思います。その時にもともと存在した規則をなぜ残したのか今一つ分からないのですが、唐沢先生および畠中先生にご教示いただければと思います。

唐沢 特化則の初の制定は昭和46年であり、私の一世代前の専門官が中心となってつくった規則です。ご承知のようにその当時は公害問題が叫ばれていまして、その影響でつくられたといっても過言ではありません。なぜ有機則との関連をきちんと整理しなかったのかについては、私は直接の当事者ではないので想像にすぎませんが、有機則は業務列举方式です。つまり、有害物質が飛散する場合に規制をかけるという発想ではなく、一定の有機溶剤業務に規制をかけるというやり方です。これは鉛中毒予防規則も同様です。したがって、特化則に関しては昭和46年の制定当時から、特定化学物質が発散する事業場を対象として、事業者にとって一定の健康障害予防措置を義務付けるという考え方が基本にあったのかと思います。しかも、特化則が規制対象とする物質はがん原性物質のように、比較的健康被害の重篤性が認められた物質に限って規制対象にしてきたという経緯があります。その後、昭和48年～50年当時の職業がん問題、塩化ビニル障害の問題がきっかけですが、それ以外にも以前からずっと使用されてきた六価クロムを原因とする職業がんの問題が顕在化して社会問題化したということで、昭和51年から52年にかけて法律レベルで化学物質の有害性調査制度が作られたというわけです。藤森先生もご指摘のように、化学物質関係の特別労働衛生規則を、分かりやすさという点で立法化することは対応策としてはあり得ると思いますが、その際に私は労働政策審議会の議論を想像してしまいます。従来の特化規則について、事業者や関係労働者のみなさんが一生懸命勉強されて、ほとんどの事業場では遵守されていると思われるので、いったんそれを反故にして統一的な規則を作ることは、理念としては合理的だと思いますが、規制を受ける現場の当事者にきちんと理解していただけるかどうか、その点について懸念材料が少々あるのではないかと思います。いずれにせよ過去の安全衛生行政の歴史をみると、昭和52年当時の化学物質の有害性調査は未然防止対策になったと思いますが、それ以前はやはり健康障害が現に起きてそれに対応する形で各規則を定めてきたという経緯がありますので、そういう意味では統一的な思想に基づいて化学物質を規制対象とする統一的な規則は作りにくかった事情があったと思います。現段階で、各規

則を今一度統一的な観点から再編成するとすれば、先ほども申しましたように、業務列挙方式の有機則や鉛則を、それぞれの規制対象となる有害物質の飛散に労働者がばく露する状態を想定して統一的な規則に改変するというのは、やり方としては可能かと思えます。ただ、先ほども言いましたように、労働政策審議会の議論でなされるであろう問題提起にどう応えるのかが気になります。

三柴 畠中先生、いかがでしょうか。

畠中 唐沢先生がお答えくださったとおりであると思えます。

三柴 今のお話をうかがっていると、今の法制度で慣れている人が多いということが要因で規則の統一が難しいのではないかという感じを受けましたが、社会的なインパクトという意味ではいかがでしょうか。要は、作業環境測定法自体もそうだと思うのですが、規則でも法律でも単独立法をつくったということで、立法サイドとして重視している問題を提示し、しかるべき対策を促すという宣伝効果も狙っていたと思えます。こういうものを一本の規則にまとめてしまうと、それぞれの規制が個別にはたいして重要でないかのような印象を与えてしまうのではないか、一緒くたにしてしまうとインパクトが弱まるのではないか、そういう意見はなかったものでしょうか。

唐沢 私は直接の当事者ではないので想像の範囲で申し上げますが、単独の規則をつくれば世間的なアピール効果があるから単独にしようという発想は、当時の担当者にはおそらくなかったでしょう。

三柴 ありがとうございます。他にご意見・ご質問いかがでしょうか。

藤森 私の方からよろしいでしょうか。先ほどの報告の途中で、ダイオキシンが安衛則に規定された経緯についてお話しました。そこで私はダイオキシンが「招かれざる客」という性質のものであるとしましたが、結局独立した特別規則とならずに安衛則の一部となったわけですが、実はその辺りの事情を調べてもよく分からなかったものですから、ご教示いただければと思います。

唐沢 あれはたしか何代か後の課長のときに規則化されたものです。藤森先生もご指摘のようにダイオキシンは「招かれざる客」であり、目的的に製造するものではないですね。だから、労働衛生関係の独立した特別規則で規制するのになじまなかったために、安衛則の一部として規制したのではないかと考えています。

藤森 ありがとうございます。もう一つよろしいでしょうか。有機溶剤などの適用および適用除外の問題についてですが、玉泉先生ほか現場の監督官の方のご苦勞がわからず、相手に説明する際に躊躇せざるを得ない場面だとか、あるいはラフな言い方になりますが、事業者にとって大きな関心事ですが適用するという前提から入っていく方がいいのではないか、などなどその辺りのことを現場サイドの実情を教えていただければと思います。

三柴 森山さん、いかがでしょうか。

森山 有機則は第2条、第3条のように消費量で適用除外か否かが決まりますが、実際には境界事例というのがあまり存在しません。あるとすれば研究所などで使用している例がありがちなパターンです。研究所では消費量を記録しているので、適用除外か否か判断に困ることは実際にはありません。むしろパーセンテージの面で有機則の適用があるか否かという問題の方が、SDSをみないと分からないものですから、判断に困る場合が多いと思います。適用除外に関して一番困るのは第13条で、どれくらいの大きさであればいいのかについて事例の蓄積が労基署の内部でなされていないので、これは許可できるのか否かについて問いかけをあまりしていません。

三柴 篠原さん、適用除外と特例の適用の問題についていかがですか。

篠原 ごく最近あったのはコバルト特化則、特定化学物質の第2類物質です。これが使用されていて湿式でやっていたのですが、作業環境測定をやってみたら管理区分1でした。しかし、監督署から特化則違反の勧告を受けまして、特化則第6条に濃度の薄い場合の特例規定がありますが、たまたまOBの技官の方に尋ねたところ、40年間労働行政に携わっていて1度も経験したことがないとのことでした。有機則はけっこうあるようですが。基本的には第6条の適用除外についてもこれから考えていこうという意見もあります。

三柴 行政官側にも詳しい人がいないと、実質的には適用除外や特例の適用が難しくなってくるということでしょうか。

篠原 そう感じるところです。

藤森 ありがとうございます。今仰ったように、実態としてあまりないというか、現場で躊躇する場面があるのではないかと思ったものですから質問させていただいた次第です。

三柴 他によろしいでしょうか。

玉泉 藤森資料58頁の「5 各特別規則統合の可能性」について、藤森先生にはぜひ案を出してほしいと思っています。私も特化と有機溶剤の作業主任者の講習をやっていますが、特別有機溶剤の話になると、聴く方はほとんど理解していません。1%超えて、5%超えて、作業主任者が入り乱れるとなると、事業者の方が大変困っています。有機溶剤と特別有機溶剤を使用していると、特化と有機溶剤の作業主任者それぞれについて3日間ずつ同じような話を聴かないといけません。現場では単独の溶剤はありませんので、ほとんどが混合物質ですから、一つの混合物質を使用するのに両方の資格が必要になります。現場ではこのように経済的にも困難を来しています。教える方も図式など用いて教えますが、講習の受講者もさっぱり理解していないのではないかと思います。そういう意味でも、ぜひ特化則、有機則の統合の可能性に関する提言をしていただけるのを楽しみにしています。



藤森 先生方には大変有意義なお話をいただきありがとうございます。今後も検証を深めていきたいと思っております。

三柴 今厚労省で化学物質対策の政策を見直そうということで検討会を開催していますが、基本的な背景は中小企業で「特別規則外」の被害が相応数出ているということです。なので、ある程度統一的で現場において実効性のある施策を再編する必要があるのではないかとということです。現行の法制度でも、リスクアセスメントは努力義務ではあるけれども一応明文規定がありますし、その他ラベル表示だとかSDSであるとか、努力義務の範囲であればGHS分類があるところについては一応立法の手当がされています。しかし、努力義務というのは現場では、特に中小企業では規定が存在しないのと同じなので、強制力が弱いんです。他方、リスク判明しているところについて講ずべき措置というのは、行政も強調するように、衛生基準の定めがあり保護具の装着などやるべきことは一応定められています。そうすると、衛生基準として明文化されていることはある程度明確で、さほど種類も多くありません。つまり、どんな物質が相手であったとしても、やらなければいけないことはある程度決まって来るのではないかとことも言えると思います。専門家的には物質や作業に応じてやるべき措置というのは非常に細分化できるのですが、法制度的な運用を考えるとやるべきことをまず強調しなければいけないレベルの話もあるのかもしれない。

唐沢 現行の労働衛生関係の特別規則で規制されている物質については、リスクアセスメントを実施するまでもなく一定の措置をしなければ労働者の健康障害生じることが明白なわけです。そういう意味では、特化則や有機則などの既存の化学物質関係の特別規則は存在価値があるとは言えるでしょう。三柴先生が仰った検討会が3月1日にも開催されるようですが、その資料が昨日あたりにインターネット上で公表されました。ざっと拝読した限り、規制の軸足を技術的管理に移行するというので、将来有機則、特化則、鉛則は廃止するといった内容が書かれていたようです。そうすると一つ気になったのは、事業者リスクアセスメントを実施させる際に一定の能力のある人材にこれを行わせることが想定されているようですが、事業者が技術的管理をまったくやっていたいなかった場合の責任はどうなるのかという疑問を少々感じました。

三柴 検討会でも再三主張しているのですが、石崎さんが調査してくれたところにも書いてありますが、民事の裁判例ではかなり体系的な（システムティックな）化学物質管理を実施していないと過失責任を問われる旨指摘されてきたところです。ある意味安衛法令や監督行政規制はこれを後追いしている部分もあります。もちろん、民事裁判においては具体的な事件があったうえで責任の切り分け論になりますから、その分ラジカルなことを言い易いわけですが、努力義務規定であっても現に被災者が発生して事業者が筋論的にやるべきことをやっていたいなかったというのであれば、責任を負わされるわけです。そういう点も視野に入れながら基本的な思想として、化学物質は「よいお付き合い」をすべき相手でありながら、付き合い方を間違えると噛み殺されるという視点を持つべきだというのが現在の我々の共通認識です。だから、単に規制を緩和したりすればいいというのではなく、原則はきちっと示しておいて、その原則を外れる場合には相応の専門家のクレジットを得なければならない、そういう手順を踏んでいなかっ

た場合には、しかるべき制裁を科し、これは民事だけではなく公法的なものも含まれます。我々はそういう方向性を模索しているところです。

森 一点よろしいでしょうか。化学物質のリスクアセスメントですが、ラベル表示・SDS交付義務対象は674物質ありますが、これは義務規定ですね。

三柴 その通りです。その674物質については義務規定です。

森 リスクアセスメントが実施されていない理由の中に、かなりの部分衛生管理者の能力的な問題が含まれていると思うのですが、非常にいいツールがあるにもかかわらずリスクアセスメントの結果を解釈するためのリテラシーが低いようです。その点も併せて解決しないと、いかなる法令で規制されていたとしても意味がないと思います。

三柴 全く同じ認識です。だからこそ、今回大きく発想を変えようと考えている点があります。今までは危ないだろうと思われる物質や作業に関して専門家をつけろという仕組みにしていました。しかし私に言わせると、それではダメで、専門家を増やすためにはニーズをつくらなければならないので、やや厳しい目の規制をかけておいて、リスクアセスメントも限りなく義務規定に近い形にしてゆく。674物質だけでなく、GHS分類があるものについては全て対象化するというようにしたうえで、もし免除を求めるのであれば専門家のクレジットを得なければならないという内容にする。そうすれば自ずとニーズが生まれてくるはずですが。現状として化学物質対策をしようにも、人材がないという調査結果がしばしば見受けられます。しかし私に言わせれば本末転倒で、経営者が化学物質対策を重視していないから、人材も体勢も整っていないのではないのでしょうか。なので、化学物質対策を重視させるためには、規制の力という説得力を利用した方がいいのではないかと、今のところそういう発想で進めています。現在出ている中間報告でも、まずリスクアセスメントは限りなく義務化した上で、特別規則についても免除を欲するのであれば専門家を活用するよう、ハッキリと書いてもらっています。

森 まさに「卵が先か、鶏が先か」ですね。要はニーズが先に動かないと、人材の養成には時間がかかりますから、そこには全く手当がなされないと思うので、三柴先生のご指摘の通りだと思います。

三柴 他によろしいでしょうか。本日のメインイベントは以上のおりで、あとは研究経過報告をお願いしたいと思います。まずは石崎先生、お願いいたします。

石崎 昨年度は作業環境測定評価辺りを中心に検討しましたので、今年度は健康診断に関する規定内容であるとか、その変遷や適用の実態についての調査を中心に進めていこうという方針であります。分担報告書（※以下「石崎資料」とする）冒頭の「研究要旨」にも書きましたが、作業環境測定はその結果を労働環境の改善につなげていくことが重要かと思いますが、健康管理の中心となる健康診断においても、畠中先生も書かれていたとおり、その後の就業上の措置といったことにつなげていくことが重要になります。また、健康診断の結果、それを労働環境の改善につなげるということで、健康管理が作業環境管理

に相互に影響していくことが重要であると理解しています。また、今回調査の過程で感じたこととしては、作業環境測定、健康診断のいずれにおいても専門家の参与、そして労働者に結果をフィードバックすることが重要であるということです。沿革としては、作業環境測定も技術の展開や医学的知見の進展によって発達しているし、本日の会合でも再三話題になっていますが、法令ではなく通達やガイドラインでカバーされている範囲も非常に広いです。全体的にはそのような内容です。

具体的な内容については、特に興味深かった点についてお話しつつ、先生方にご相談させていただきたい点をかいつまんでお話しさせていただければと思います。

健康診断の規定内容については先生方もご承知の通りかと思いますが、沿革を概観したときに興味深いと思ったのは、戦時下において労働力の確保が必要であるにもかかわらず、労働者の健康状態が低下し、結核が蔓延していたという状況が背景にあったということです。法令上の規定が設けられたのは、工場危害予防及衛生規則の改正に伴ってのことでしたが、それ以前にも通達的なもので健康診断の実施等が勧奨されていました。その後、工場法施行規則の中で健康診断の規定が設けられるようになり、そこでは健康診断の結果の記録の保存や事後措置についても規定がなされていたという点も注目されるべきかと思います。ここでお尋ねしたかった点としては、工場法施行規則においては、事後措置に当たっては「医師の意見を聴取したうえで」という規定がありましたが、労基法時代になると事後措置については労基法の中にも規定が設けられました。しかし、医師の意見聴取に関する規定が欠落しています。これは、従前の「工場医」から「医師である衛生管理者」が健康診断を担うことになったことも影響しているのかとも思うのですが、なぜこれが欠落してしまったのかについてご教示いただければと思います。このようにして労基法で規定がなされ、その後安衛法のもとでの安衛則で具体的に規定されていくといった経緯をたどります。これとは別に、特別則において特殊健康診断の規定が順次設けられ、その後安衛法の中に根拠規定ができるという流れをたどります。

このほか、定期健康診断については疾病構造の変化によって疾病項目の変更が生じています。当初は結核の予防が中心だったのに対し、高齢化社会の進展によって脳心臓疾患の防止が重要になると、これに応じた項目が追加されていくというところです。背景となった災害についても、そういった疾病構造の変化等を示すのがよろしいかということで、いくつかの図表を追加しています。石崎資料120頁掲載の厚生労働白書に示されているように、結核死亡者数が減少し、脳血管疾患が死因の第一位を占めるようになっていきました。

また、法学系の先生方にご意見を伺いたいのですが、各規定の私法上の効果に関する問題です。まず、健康診断の規定に関して実施義務に違反した場合に、そのことが安全配慮義務違反ないし注意義務違反の内容として参酌されることは、判例においても確認されるところです。これに加えて、この条文に基づいて履行請求権が生じるか否かについてですが、健康診断についてはある意味労働者の個人的利益に還元しうるものなので、これを肯定する考え方も成り立ち得ると思う反面、最初に述べた労働衛生3管理の一つとして実施されて初めて意味を持つものであることを考えると、個別の紛争の中の権利義務関係の枠組みで処理することが適切といえるのか、そういう観点から私見としては履行請求権は認められないのではないかと感じを持っています。この点ぜひ他の先生方のご意見を伺えれば幸いです。他方、安衛法第66条の6に健康診断の結果の通知に関する規定が設けられ、これは労働者が自ら自主的に健康管理に取り組むことが重要であるということです。この規定における通知については、履行請求権を認めてもいいのではないかと感じしているところです。この辺りについてもご意見を伺えればと思

います。

本プロジェクトの実態調査に基づく適用の実際も適宜追加させていただいています。健康診断関連では、やはり定期健康診断を実施していなかったケースが2件ほどあり、各自に任せている、あるいは常時使用する労働者にあたるか否か確認が必要であるといったことなどが書かれています。

適用の実際の中で、定期健康診断、特殊健康診断の実施状況に関する統計も挙げていますが、不思議に感じたのは特殊健康診断の実施率が事業所調査では有機溶剤や特定化学物質については他と比べると低い数値が出ています。これに対し、労働者調査（個人調査）ではそうでもない数値が出ていて、他方石綿の方は数値が低くなっているところです。こうした数値の違いの原因が何であるのか、お考えをお聞かせいただけると大変ありがたく思います。

本日の報告は以上のとおりです。ご清聴ありがとうございました。

三柴 ありがとうございます。割と技術的な議論が続いてきましたので、法学的な議論にも踏み込んでみたいと思います。ちょうど健診関係規定の私法的効果についてお尋ねがありました。ちょうどこの問題については、鎌田先生が非常に重厚な論稿を發表されていますので、後ほどご意見を伺えればと思います。安衛法規の履行請求の可能性については、高島屋工作所事件で義務の内容を特定できるか、つまり具体的に何をすればいいのかがハッキリ分かるか否かが問題であることが指摘されています。また、規定の名宛人が誰で規定の定め方かどうか、といったところからうかがえる制定の趣旨がどうなっているかも重要な要素となってきます。労働者を後見的に保護する趣旨の規定なのか、労働者に一定の主體的な関与を求める規定なのか、などといった点が勘案されて決まってくると思います。日本ではまだ基本的にはこれを肯定した事案は見受けられません。そういう中、この状況を突破するべく執筆されたのが鎌田先生の論稿です。鎌田先生、ご意見うかがえますでしょうか。

鎌田 貴重な問題提起をありがとうございました。私自身最近では履行請求に関してはあまり議論していませんが、あらためて検討させていただきますと、安衛法第66条の6所定の健康診断の結果通知については、石崎さんも履行請求を認めてもいいのではないかとのご意見でした。これについては私もあまり考えていませんで、今あらためて条文を読んでもみると、かなり内容が特定されているので、履行請求は不可能ではないと思います。ただ、履行請求をする場合には先ほど三柴先生もご指摘されたように、そもそも第66条の6の規定は誰を保護する目的で何のためにこのような通知義務を定めたのかを考えなければなりません。なぜこんなことを言うのかというと、労働者にとっては通知義務で満足する話ではなく、通知された後に何を請求するかが本質的な要求になるわけです。それとの関係で通知義務というものがどういう位置づけになるのかを考える必要があるのではないかと思います。労働者にとっては通知されればそれで終わりということではなく、その後に職場の変更や就業制限など様々な要求をしますが、その履行請求を結び付ける形で検討していくのだろうと思います。ですから、第66条の6が労働者の保護を目的としているものと一般的には言われていますが、一連のプロセスの中でどういう位置づけでこの規定が定められているのか、それが履行請求を考える場合のポイントではないでしょうか。“義務内容の特定”という点では特定されているので、その点は問題ないと思います。

それと、そもそも安全配慮義務の履行請求を考える場合に、安衛法の規定で定められた義務の法的性質をどう捉えるかという大問題があります。つまり、第66条の6がそのまま私法的効力を持つことを



前提として履行請求を認めているわけですが、そもそもそうではないという意見もあるわけですが。私としては、安衛法の規定全てが私法的効力を持つと考えるのは無理があると思うので、安衛法が定める目的、プロセスなどといったものを考慮したうえで、安衛法上の義務であっても同時に私法的効力を持つ場合があるのではないかと考えています。ですから、第66条の6がそういう趣旨であるとすれば、私法的効力を持っていると言えるものと思います。

三柴先生の論文を読むと、ドイツ民法第618条（使用者の安全配慮義務の規定）のようなものを想定されているのかもしれませんが、安衛法で定める義務はそのまま私法的効力を持つと考えることができるのではないかと立論されています。いわゆる付随義務としての安全配慮義務とは性質の異なるものとして、私法的効力を持った安衛法上の義務としての安全配慮義務を少し区分けして考えているようですが、これについては私もそういう考え方はあり得ると思っています。

三柴 今議論している内容について法学系以外の先生に説明しますと、安全配慮義務が何なのかについてはご存知かと思いますが、これはたいていの場合労災事故が発生した後に使用者に賠償責任を問うことができるか否かという局面で用いられるものです。しかし鎌田先生はより積極的に、安全配慮義務を予防のために使うことができないか、つまり未だ被害が生じていないにもかかわらず、使用者に対して「安全配慮義務を果たせ」という内容の判決を求めることができるかという議論をしているところです。判例においては、例外的ではあるものの不可能ではないという司法的判断が一般論として出されており、学説においてはもっと積極的に論じてもいいのではないかと議論もあり、その急先鋒が鎌田先生で非常にバランスのとれた議論をなさっています。

安衛法上の健診規定に関して言えば、まず「事業者健診を実施せよ」と求める局面と、「その結果を踏まえて医師の意見を聴取せよ」とする局面と、「結果を本人にフィードバックしなさい」という局面です。この辺りまでは義務になっています。また、医師から意見を聴いて就業上の措置を講じ、個別の健康配慮をすることも義務とされています。他方、健診の結果を踏まえて本人へのアドバイスや保健指導をすることは努力義務ということになっています。そういう建て付けです。そもそも健診制度というのは労働者の関与をどう考えているのか、趣旨としては国民の健康を守るだの、産業の利益を守るだの、どういう趣旨で制度設計されているのか、その点についてご意見うかがえますでしょうか。

森 義務の範囲においては高齢者の問題があったように、労働者側の適性を評価しないと健康を保てないような要素があるという範囲においては、義務になっているというのが基本だと思います。それにプラスして、個人がその結果を利用しようとするような局面においては、努力義務になっていると解釈しています。特殊健診も一般健診も通知義務については安衛法第66条の6に定められているので、労働者の知る権利が保護されるべきだという議論があり、しかも自分自身の血液を提供し自分自身のプライバシー情報を提供している場合に、その情報が間違っただけで対応される場合もあります。にもかかわらず、本人に知らされていないということは、プライバシーというものは守ると同時に自分でコントロールするという要素もあるので、それゆえに一般健診の通知義務が定められたものを理解していました。

石崎 一般健診も含め自分で健康管理をするという趣旨が通知義務の背景にあるとすると、自分で健康情報をコントロールして自身が健康を管理するという発想は特殊健診でも一般健診でも同じ・・・

森 コントロールというのは自分で知って自分で動くということだけではなく、事業者が自分に関するどのような情報を保有しているかという問題が先にあったのではないかとことです。

鎌田 大変興味深い問題で、森先生が仰ったように、個人情報保護の観点から第66条の6が制定されたということになると、通知の履行請求は難しいかもしれません。履行請求というのは労働者が自らの利益を守るために認めるとするのが本来的な趣旨ですから、事業者が持っている個人情報の管理云々であるならば、そういうシステムを構築せよということは言えると思いますが、それを履行請求するのは難しいと思います。

森 第66条の6は一般健診も特殊健診も両方含めていますので、特殊健診においては自分がどのように曝露していてどのような職業病に罹患しているのかという要素も含まれていると思います。両方が含まれている点が議論になると思います。

三柴 特殊健診はもともと作業環境をよくさせるために作られた制度で、一般健診は大ざっぱに言えば事業者が病気の人を下手に使用させないようにするためです。同時に、本人にも自己管理をきちんとさせるようにする趣旨でもあります。

森 日本の特殊健診の場合、最終的には判定の結果仕事をさせないようにすることですから、環境の問題へのフィードバックだけではありません。

三柴 その趣旨が労働者の何らかの法的権利まで裏付ける趣旨ととることができるか、民事裁判ではそういう問題になると思います。

北岡 定期健康診断における私法上の契約主体は誰と誰か、またそれはどのような契約内容なのかです。まず考えられるのは事業者と定期健康診断等を実施する医療機関、彼らが健康診断について第三者のためにする契約という読み方をすべきでしょうか。健康診断の対象主体は事業者ではなく労働者ですから、第三者のためにする契約にかなり近いものと言えます。私法上の契約において、診断結果が出た場合、その結果について実施主体は誰に対して報告しなければならないのか。普通に考えると健康診断の実施主体たる医療機関から事業者ということになりますが、第三者のために実施しているわけですから、労働者についてどう観念すればいいのかが難しいところです。

石崎 ご指摘のように健康診断を実施するのは外部の医療機関であることが多いので、健康診断の規定そのものについては履行請求は難しいと感じていました。ただ、通知義務の名宛人は実施機関ではなく、実施機関が実施した健診の結果が使用者に伝えられ使用者の手元にとどまっている状況を考えた場合に・・・そうですね・・・健康診断実施義務がなければ通知義務も抽出できない、ということになるのでしょうか。

北岡 通知に関して言えば、場合によっては労働者が受診機関に直接請求できないのかという話になります。私法上の契約から健診結果について通知を受ける権利が第三者としてあるとして、履行請求というより私法上の請求権として生じうるか否かですね。

三柴 原理的には安衛法に基づく民事法上の解釈を構築する際には、健診機関は単なる手足、つまり事業者の履行補助者ないし履行代行者という位置づけになるはずですが、筋論とすれば労使関係の枠組み、すなわち労働者が使用者に対して請求するという枠組みの中で考えるほかありません。ただし、健診機関などが絡んできたときに、そこに直接請求できるような解釈論は可能だと思います。

鎌田 大変興味深い議論ですね。北岡さんご指摘の通り、そもそも健康診断の契約関係の構造如何について安衛法上は議論になりますが、安衛法上の規定が丸ごと安全配慮義務の内容になっているわけではないので、安全配慮義務の内容として通知義務が含まれているのであれば履行請求は可能ではないかという感じで整理すればいいのではないのでしょうか。第三者のためにする契約云々は、事業者と健診実施機関との間の契約に第三者（労働者）のための保護義務が関わってくるかという話だと思いますが、そういう考え方もあり得ないわけではないでしょう。安全配慮義務は、労使間の労働契約上の付随義務だから、その点はあまりこだわらなくてもいいのではないかと思います。ただし、事業主が通知するような内容を保有しているのか否かという問題が出てきます。そうすると、単純に履行請求が認められるかという話になってきます。しかるべき情報を使用者が保有していないのに履行を請求されたとしても、それに対応することはできません。情報を保有していないとしても、事業者が健診実施機関に通知せよと要請することはできますが、そのような状況を想定した話ではないかと思います。

三柴 ありがとうございます。石崎先生のほうで他に確認しておきたい点はありますか。

石崎 報告の中でも触れましたが、工場法施行規則においては、事後措置に当たっては「医師の意見を聴取したうえで」という規定がありましたが、労基法時代になると医師の意見聴取に関する規定が欠落しています。その背景や理由についてご教示いただければと思います。

三柴 この点畠中先生、唐沢先生いかがでしょうか。

畠中 制定当時の安衛法にもこのような規定はなかったですね。

石崎 なかったです。

畠中 これについては・・・私も答えに迷うところですね。

北岡 単なる思い付きで恐縮ですが、旧労基法時代には衛生管理者が産業医の役割を担っていましたが、その辺りが影響している可能性はありますか。

石崎 私もその点は怪しいなと思っていました、当時は「産業医」ではなく「医師である衛生管理者」と称されていました。ただそうだとすれば、「医師である衛生管理者の意見を聴取」云々という規定があってもいいはずなのですが・・・。

北岡 あるいは旧労基法時代に、衛生管理者の職務権限規程や責任規程の中にそのようなルールを読み込めた可能性はあったでしょうか。

石崎 健康診断を実施する義務は規定されていますが、この点は工場法時代とあまり変わっていません。

森 「医師である衛生管理者」も現在の産業医と同じように、事業場の規模によって選任されていませんから、一般健診がそれ以外のところにも関わっているのに、そこで意見を聴取しなくてもいいというのは難しいと思うのですが。

石崎 なるほど、産業医がいない事業場もあるのに・・・

森 現行の労働安全衛生法でも、指針（健康診断結果に基づき事業者が講ずべき措置に関する指針、平成8年10月1日健康診断結果措置指針公示第1号、最終改正・平成29年4月14日健康診断結果措置指針公示第9号）によれば、「産業医の選任義務のない事業場においては、労働者の健康管理等を行うのに必要な医学に関する知識を有する医師等から意見を聴くことが適当」とされています。

三柴 昔の安衛関係の規定をみていて、医師ではないのに衛生管理者に健診などの権限を付与しているものは見たことがありません。やはり、健診を行うのは医師です。衛生管理者にからめてというのはあるかもしれませんが、我々が今イメージしているものとは違うかもしれません。

畠中 石崎先生に一点おうかがいしたいのですが、特定業務健診や海外派遣労働者に対する健診、あるいは給食従業員の検便など、それらの位置付けについてどのように執筆されていますか。

石崎 規定の内容は説明していますが、位置づけに関してまで十分踏み込んだ検討はまだできていません。ただ、特定業務従事者の健診については、森先生がすでに特殊健康診断との関係性について指摘されていたこともあり、特定業務従事者健診の位置付けがどうなっているかについては説明しています。海外派遣労働者や給食従事者についてはまだ各位置付けは検討しきれていない状況です。

畠中 一つは健診に要した時間に相当する賃金の問題です。この点についてはいかがでしょうか。

石崎 その問題について現行通達の内容は紹介しています。

畠中 それが適用されるかどうかですね。せっきゃくこれだけのコンメンタールを執筆されるのであれば、ぜひ書いておくべき問題ではないかと思います。安衛法施行時に出された局長通達では、健診の受診に



要した時間についての賃金の支払いについては、労働者一般に対して行われる一般健康診断は一般的な健康確保を図ることを目的として事業者による実施義務を課したものであり、業務遂行との関連において行われるものではないので、当然には事業者がこれを負担すべきものではないという内容になっています。要するに、その健診が労働者一般に対して行われる一般健康診断に該当するか否かが重要ではないでしょうか。

石崎 そうすると、海外派遣者や給食従事者は・・・

畠中 それらの方々もそうですし、また、年2回実施される特定業務従事者健診の2回目の健診をどうするかですね。

石崎 そう言われてみると、確かにその通りですね。労働時間として扱うのが望ましいように思います。また、森先生が報告書の中で触れられていたように思いますが、そもそも定健康診断自体についても所定労働時間内に実施すべきではないかという議論をされていて、この点私自身がどう考えるかはまだ固まっていないために踏み込んだ検討はしていないのですが、仮にそうしたとすると一律に労働時間という扱いになるでしょう。通達の整理を前提とするとしても、畠中先生が仰ったように特定業務従事者について別途の扱いをすることはあり得るかと思えます。

畠中 そうですね。これが局長通達でいう一般健診に入るかどうかという話になるのではないかと思います。

石崎 私も少々性格が違うような気がしまして、これが一般健康診断に含まれることに驚きながら執筆していました。

畠中 安全衛生法上、一般健康診断の定義は、少なくとも法令上の定義としてはありません。その辺りをどう理解するかですね。今挙げた3つ、すなわち特定業務健診、海外派遣労働者に対する健診、給食従業員の検便は、業務関連の健康診断であって、労働者一般に対して広く行われる一般健康診断とは異なるものではないかと思えます。

石崎 私の理解では、「標的臓器」を念頭に置いた診断かどうかで分けられているのだらうと思いますが、ただ一般健康診断でも脳心臓疾患の予防などをメインにしているとすると、業務との関連性はグラデーションになってくる部分もあるのかもしれない。

畠中 そもそも、昭和17年以来の一般健康診断、というよりもすべての労働者を対象とした健康診断は、流れからいえばまず最初は主として結核予防を目的としたものでした。そして、健診項目は昭和22年の労働基準法に基づく健康診断に丸ごと引き継がれていますから、その性質は昭和47年まで継続しているわけです。昭和47年に初めて健診項目として、たとえば業務歴の調査などが追加されています。ここで初めて労働者健診的な性格がはっきりしてきました。その後健診項目は次々に追加され、今仰っ

たような成人病対策のようなものも入ってきています。以上のような流れになっていると思います。特定業務健診はこれとは別で、昭和17年にすでに規定されていたわけですが、当時は今でいう特殊健診という位置づけだったと言えるのではないのでしょうか。

森 ホルムアルデヒドやエチレンオキシドについては特定業務従事者健診を実施させるようにして、特殊健診が作れなかったときに苦し紛れに特定業務従事者健診に含めてしまったから、畠中先生が仰るように、特殊健診と同じだと考えて事業者が労働時間内に実施するものとした方がスッキリしますよね。

石崎 そうですね。

畠中 私もそう思います。この辺り、コンメンタールでどう執筆されるかですね。

三柴 森先生も仰るように、特定健診と特殊健診は統合してしまった方がいいと思います。もしその旨執筆していただけるようであればお願いいたします。また、医療あるいは産業保健の論理として、イギリスには勤労者医療という考え方があって、要するに実地医科の先生が産業に触手を伸ばすという考え方です。普段の健康管理はかかりつけの医師が行なっていて、そのために職場まで踏み込む必要があるという発想で産業保健が成り立っているわけです。それに対し、職域のことは安全衛生の体系の中で労働法の問題として扱い、その延長で必要とあれば地域の方まで踏み込んで取り組まなければならない。いずれの発想を起点とするかは、国によって違いがあります。現在問題になっている感染症予防についてどちらからアプローチするかはその国の歴史と文化によって違いが出るので、その辺りも念頭に置いていただければと思います。「勤労者医療」というキーワードでお分かりになると思います。

では次に阿部（理香）先生、進捗状況のご報告をお願いします。

阿部 簡潔ながら進捗状況を報告させていただきます。私の担当は安衛法第59条から第63条までで、「第六章 労働者の就業に当たつての措置」に関する条項です。第59条は、労働者を新たに雇い入れたときと、作業内容を変更したときに、事業者が安全衛生教育の実施が罰則付きで義務づけた規定です（第1項、第2項）。同条第3項は一定の危険有害業務について特別教育の実施をこれも罰則付きで義務付けています。安全衛生に関わる教育等については、安衛法第59条から第63条までの範囲でいうと、初めてその業務に従事する際の言わば入口の教育が第59条第1項・第2項のベースにあり、より危険なものについては第3項の特別教育を実施しなければいけないことになっています。さらに危険有害の程度が重大なものについては、有資格者のみが従事できるという就業制限を課す（第61条）という階層構造になっているものと理解しています。その上で第59条との関係で考えていたのが、三柴先生や監督官の先生方にご相談させていただきましたが、同条第1項・第2項の安全衛生教育について事業者がどこまでしないといけないのかという点を問題意識として感じていました。先ほども高齢者に対する事業者の責任の話が出たところですが、より長く働けるよう中高年者の雇用促進が展開される状況の中で、定年までの間事務職に従事していた労働者が継続雇用された結果、新たな職場として工場等で新たな業務に就くこともあり得ます。そのような場合に第59条に基づいて、事業者が安全衛生教育を行うこととなりますが、労働者が高齢であるとか、あるいは外国人であるとか、そういった労働者の特性に応じた教

育内容を実施するべきであると考えていましたが、色々と各先生方にご相談させていただいた中で、安衛則第35条に教育すべき事項が定められていますが、その態様などについては条文上特に問題にされていません。また、第59条第1項・第2項が罰則付きで課している安全教育は、事業者が広く実施しなければならない入り口の教育であることを考えると、より高度な安全教育を要請することはこの条文では難しいかもしれないと考えられます。第59条に関わることで、労働者の特性に応じた安全衛生教育を雇入れ時や作業内容変更時の教育内容について執筆できればと思っていましたが、少々厳しいと感じているところです。今のところ検討も十分ではないので、どのようにすべきか考えているところです。

第60条と第60条の2については基本的に加筆修正した部分はなく、第61条の就業制限に関わる箇所を加筆させていただきました。昨年度の報告書では、就業制限にかかる業務については特に詳しく書いていなかったのですが、この点については図表を活用し分かりにくい用語は説明書きを参照しながら詳しく加筆したいと思います。また、三柴先生からお送りいただいた行政官のアンケート調査結果をもとに、適用の実際の加筆をしたところです。まず、特別教育と就業制限に関するところで、その関係性についてですが、第59条第3項の特別教育に関する規定の名宛人は事業者で、違反に対しては第119条第1号に基づいて刑事罰が科されます。特別教育の実施は事業者の義務になるので、これを受けずに業務に就いた労働者が処罰されることはありませんが、このような労働者が他の規定によって処罰される余地はないのかご指導いただければと思います。

第61条第1項の就業制限については、事業者が資格を有しない者に対して安衛令第20条に定める16業務に就かせることを禁止しています。同項にいう「資格を有する者でなければ」とは、事業主、法人、役員等であっても、当該業務を行うための資格を有することを意味しています。第2項は「前項の規定により当該業務につくことができる者以外の者は、当該業務を行なつてはならない」ということで、制限業務に労働者を就かせた事業者だけではなく、制限業務に従事した労働者も処罰の対象になる旨規定しています。なので、この条文の適用対象の範囲は、第59条第3項よりも広範であるということは、監督官の方が示しています。引用の仕方等を含めて改編をしていますが、この辺りご指摘いただきたいと思います。適用事例として回答されていたのは、フォークリフトを運転した代表取締役が指導を受けたことがあるということでした。適用の実際については、送検事例を活用しています。第61条においては、無資格者の就労のケースが多いです。そのうち代表的な事案を紹介するつもりです。この条文の適用対象者に関して、監督官の方が、実務上の観点から解釈に争いがある旨書いていた箇所があり、その辺りがよく分からなかった点です。実務上も第1項が適用され、無資格の人を対象業務に就かせた事業者が処分を受けるケースが圧倒的に多いものの、この条文は無資格者を就労させた事業者のみならず、就労した当人も対象としているということです。ともあれ、第61条の適用対象範囲に争いがあるということを回答されていました。というのも、第1項は「事業者は・・・当該業務に就かせてはならない」というように規定しているところ、事業者自身が無資格で当該業務に従事した場合に本項が事業者自身に及ぶか否かが明らかではないということです。実際に、起訴例の中で第1項に基づいて起訴された例と、第2項に基づいて起訴された例とに分かれていたようです。回答例をみると、事業者自身に及ぶのかについては、解釈が分かっていると書かれています。実務家の先生方の中で運用がバラバラであるという趣旨で書かれているのかと思ったのですが、研究者の中でこの点について主張されている学説をご存知の方がいらしたらぜひご教示いただきたいと思います。仮に事業者自身が制限業務に無資格のまま就労した場合の解釈として、第1項が適用されないとした場合、第2項で処分されることとなります。他

方、事業者が事業者自身を制限業務に就かせた（つまり事業者自身が業務に就いた）場合に、事業者としての責任を第1項に基づいて負うと理解することもできます。回答例としては、第2項で処分するのは少々問題であると理解されているように読めました。第1項の適用範囲をどう考えるかという問題については、やはり同項は他者を無資格のまま就労させるという形で他者を危険にさらす趣旨で、第2項よりも重い法定刑が科されている。そうすると、事業者本人が制限された業務に就く場合は、自身を危険にさらすと考えると、他者を危険にさらすことと自分自身を危険にさらすことでは、責任の程度が異なってくると、そのようにも考えました。この辺り、まだ考えがまとまっていないので、この点についてもご指導いただきたいと思っています。また、回答の反映のさせ方も十分ではないと思われるので、これについてもご教示いただければと思います。

最後は図表になりますが、第59条第3項の特別教育と就業制限が、業務によっては階層構造になっているものがあるので、横並びで表にまとめたら分かりやすいと思い、試しに作成しました。

以上、内容の本質的部分、形式的部分についてご指導いただければと思います。

三柴 ありがとうございます。まず事務的な点ですが、図の引用の形式は、私の報告書を参考にしてください。アクセスした時点の年月日を付し、原典のサイトについてはなるべく丁寧に記述する形をとっているのですが、ぜひ参考にしてください。内容面としては、阿部さんの報告書は初年度から、あるいは普段執筆されている論稿などもそうなのかもしれませんが、法律論や労働者の健康論で個別性を重視する、特に属性に応じた対応を志向していくといった方向性がうかがわれて、非常に興味深いと思います。一般に事業者は、安全衛生では個別管理をあまりやりたがりませんし、法律で義務付けられるのを嫌がります。なので、そこにチャレンジするという意味で面白いお仕事をされているといつも思っています。今回いただいた経過報告について、先生方からご意見・ご質問ありましたらお願いいたします。

畠中 よろしいでしょうか。引用されている資料ですが、工場法の保護職工に関する就業制限関係規定を引用されていたと思いますが、それが沿革的に安全衛生法上の就業制限の源流であるという趣旨で引用されているとすれば、不要な資料ではないかと思います。工場法の保護職工に関する就業制限関係規定は、労基法では女子年少者の危険有害業務の就業制限に関する規定に引き継がれておりまして、安全衛生法制定の際には安衛法に引き継がれないまま労基法に残りましたし、現在も残っています。そういう意味では流れが切れていますので、その点ご留意された方がよろしいかと思います。

阿部 ありがとうございます。

三柴 他にいかがでしょうか。阿部さんの方から尋ねたい点はいかがでしょう。

阿部 場合によっては割愛するかもしれませんが、第59条の中で高齢者等に対するきめ細かな安全衛生教育を実施するのは厳しいと考える方が大半なのかという・・・

三柴 入り口部分では教育で属性を踏まえられるかということですよ。この点どなたかご所見お持ちでしょうか。教育センターの藤森先生はいかがでしょう。



阿部 藤森先生には個別に質問させていただきまして、やはり厳しいとのお話をいただきました。

三柴 なるほど。藤森先生がそうおっしゃる以上、そう考えざるを得ないですね（笑）。この点についてほかにお答えできるとすれば、篠原先生、玉泉先生、浅田先生あたりかと思imasので、もしご所見いただけるようであれば、後日MLでご回答いただければと思います。

それでは、そろそろ時間ですので、今回は終了とさせていただきます。本年度もご協力いただきありがとうございました。

#### 四. ヒアリング調査概要



## <ヒアリング調査概要①>

日時：2020年3月11日午前10時～午後12時30分

場所：横浜国立大学法学研究棟

ヒアリング対象者：森山哲（技術士・労働安全コンサルタント、一般社団法人日本労働安全衛生コンサルタント会神奈川支部長）

参考：森山技術士事務所 Web ページ<<http://www.safeyeng.co.jp/>>

ヒアリング実施者：石崎由希子（横浜国立大学准教授）、南健悟（日本大学准教授）

## <ヒアリング内容>

### ● 労働安全コンサルタント・技術士の資格を取得するに至った契機

当初は、化学プラント等や安全装置の設計を行う設計職に就いていたが、その後、営業部長へと配置転換されたことから、技術を活かして、技術士の資格を取得した。勤務先の縁で、長岡技術科学大学工学部に学士入学し、後に同大学の機械系修士課程に進学した。修士課程在学中に技術士として独立したが、原賠において法的知識が必要だと考え、労働安全コンサルタントの資格を取得しようと決意した。ところが、実際に、条文の多さや法律学の学習の大変さを認識しつつ、短時間で資格取得を目指して、約1年で労働安全コンサルタント資格を取得した。コンサルタント資格の取得は、技術士としての設計指導のために必要な知識でもあり、また、技術士資格とコンサルタント資格が2割程度関連していると考えた。その後、横浜国立大学環境情報学府（旧工学部）博士課程に進学し、ヒューマンエラーに関する論文で博士号を取得した（タイトル「A methodology of risk assessment incorporating human error at the workplaces」(Cinii 博士論文検索による)）。

### ● 労働安全コンサルタント業務の具体的内容

多くのコンサルタントは、必要に迫られて企業に所属しながら、取得する。特に、建設や土木の資格が、企業内における職務に従事するために必要な会社も多く、さらに、現場における上長（現場所長等）になるためにも必要な資格となっているという。したがって、コンサルタントのうち約8割～9割程度は企業内の人である。なお、上記の通り、現場工事に必要なために取得する人が多いことから、その具体的な内容も建設土木が多い。

建設・土木におけるコンサルタント業務で一番多いのは、職場巡視である。実際に、職場巡視を行い、気づきを得て企業へ指導をすることも多い。また、製造の場合には、生産物（製造物）の種類により現場は大きく異なる。また、建設現場は、同一の現場であったとしても、日々状況が変化する。したがって、自分の得意の現場でないことも多いが、ある程度予備知識がないと引き受けられない。コンサルタント業務を行うに当たり、仲間同士の意見交換や先輩後輩の教育指導を通じて、その知見が広がる。実際、このような意見



交換の場として、仲間同士の繋がりを作るのが、コンサルタント会の役割といえる。なお、神奈川支部で約 180 人のメンバーがあり、毎年、10 名程度が加入し、産業医の加入者も多い。コンサルタントとして独立して仕事をしている者は、会として教育するが、2～3 年程度経験を積まなければ 1 人前にはならない。

また、コンサルタントの業務として多いのが、安全衛生委員会への出席やそこでのアドバイスが挙げられる。法律上、義務付けられているわけではないが、専門家としてのアドバイスを求められたり、他にも安全衛生規程の策定や企業内安全衛生教育、安全大会における講師を引き受けたりする。

さらに、コンサルタント会を通じての依頼で、グループ企業内における関連会社への労働安全に関する監査の一環として、チェック等を行うこともある。より具体的には、大手企業から 30 者ほどの関連会社や下請企業を見て欲しいと依頼を受け、半日ばかりで書類と現場のチェックを行う。これは、親会社はコンプライアンス上、発注先等を見ておかなければならないこともあり、その関係で依頼を受けることがある。なお、コンサルタント会を通じてだけでなく、他にも中央災害防止協会や欧米系の検査会社等に依頼することもあるようである。

他にも、局部排気装置等の設計、製作、施工、メンテナンスに対するチェックを依頼されることもある。また、近年、リスクアセスメントも増えてきて、機械設備を持っているところや、建設土木、加えて、社会福祉関係等の第三次産業の事業場の労災発生率が多く、それらのところで、それぞれの事情に応じたリスクアセスメントについて指導を行う。行政のパンフレットもあるが、それだけを見て行うことはできないし、依頼先の事情に合わせて評価しなければならない。

ごく最近では、受動喫煙防止対応の業務が入ってきている。事業者である飲食店から受動喫煙防止対応についてアドバイスを求められることも増えている。現在、厚生労働省が予算を有しており、また東京都では 9 割程度の補助が出ることから、相談も多い。東京都の例で言うと、コールセンターの中にいるオペレーターは法的規制についての対応はできるが、実際の現場を見なければ受動喫煙防止のためにどうすれば良いかという対応ができないため、コンサルタントとしてのアドバイスが行われる。

一般的なコンサルタント業務からは外れるが、個人的に、労災事故原因調査に携わることもある。担当したものとしては、機械による指先の切断事故の原因調査や粉じん爆発事故における発火源の調査等を行った。このような職務はコンサルタント会に依頼があり偶然、知見を有していたことから業務を行った。なお、コンサルタント業務とは全く無関係ではあるが、個人的に子供の安全・事故調査、消費者事故調の専門員等も行っている。

#### ● コンサルタント業務に関する問題点

船会社、農業、漁業といった分野では、労働安全コンサルタントがあまり活躍していない。特に、一次産業との関係でコンサルタントの活躍が見られないように思われる。それ

でも、最近では、農業機械関係で、労働安全コンサルタントが業務を行うようになってい  
るが、農林水産省の管轄で現場に出てくれる専門家も地方組織もないというのが現状であ  
る。確かに、技術士法では、どの分野でも業務を行うことができるとされているが、労働  
安全コンサルタントは労働安全衛生法の中で規定されていることもあり、その活動領域は  
狭いように思われる。

- 労働安全コンサルタント試験について

前述したように、労働安全コンサルタント資格を取得した契機が技術士としての設計指  
導のために必要な知識であること、現場では法的知識が必要であると認識したことを挙げ  
る。

先に受験した、技術士試験の場合には、21 部門で専門性が高くなっているが、コンサル  
タント試験はかなり大雑把な区分になっている。そして、受験科目にかかわらず、実際  
には他の業務を行えることも疑問である。事実、得意分野でなくともコンサルタントが対応  
してしまっている場合もあり、これを職業倫理で対応すべき問題かもしれない。実際、コ  
ンサルタント会には倫理規定があり、違反した場合には懲戒処分もあり得るが、あくまで  
も任意団体であることから、どこまで機能しているのかも問題となる。コンサルタントを  
職業資格とし、業務独占とすることも大事ではないだろうか。

さらに現在の受験科目については、第三次産業に対応する分野や農林水産業に対応する  
ような分野がないというのも疑問である。しかし、専門を区分すると、専門分野が抜け落  
ちてしまう問題ともあるかも知れない（例えば、林業など）。また、コンサルタントがいな  
い分野が地域毎に発生してしまうという課題もあろう。

なお、指導力やコミュニケーション能力の欠如から口頭試験で不合格となる人も多いが、  
今後は、例えば、口頭試験を行うとか、論文試験を課すなどしてよりクォリティを上げる  
方法もあるかもしれない。

- 会社からのコンサルタントの依頼（継続依頼や新規依頼の割合等）

会社から新たにコンサルタントを依頼する契機として、事故があったことなどにより、  
コンプライアンス上きちんとしなさいといけないということで依頼を受けたり、中災防から  
依頼が廻ってきたりすることもある。また、社内の安全管理担当者が減少したことを補充  
するためにコンサルタントに依頼することもある。他にも、臨検時に、会社の担当者のレ  
ベルが低く、行政から勧奨されてコンサルタント会に相談してくるということもある。仕  
事量としては増加傾向にあるのではないか。

現在、神奈川支部に入ってくる新たな依頼件数は、30 件～40 件程度だが、中には 1 人  
で対応することは難しいものもある。依頼の多くは単発指導で、継続依頼の割合は 1 / 3 で、  
会社の予算的などころから、1 年の指導だけで良いというところも結構存在する。なお、顧  
問先で長いところだと 14 年続けている会社もある。

- 労災の多い企業、労働安全上問題がある企業の共通点

そもそも社内における安全衛生活動の継続性が欠けている企業において労災が多いと感じている。安全衛生は一度作っても継続しなければ、同じことを繰り返す。継続できなければ知識や経験を持った人もいなくなってしまうため、継続性が重要となる。しかし、労働安全や労働衛生のレベルが高まり、事故件数が減っても、却ってそれによって安全衛生に人とお金をさかなくなり、結果的にレベルが低下するという問題もある。結果、労災事故が発生すると、事故を起こした人が叱責され、退職して終わるだけという状況になってしまう。

ところで、労災事故の発生割合に関して、度数率と呼ばれるものがあるが、度数率では3～5というところ。すなわち、100万労働時間当たり3～5回程度の割合で労災事故が発生している。金沢区には50人程度の工場が多いが、そこだと大体3年に1回程度労災事故が生じている計算になる。3年間で人が大きく入れ替わるので、継続性という観点の問題となる。

他方で、機械設備や建物の安全性を確保することも重要である。メーカーの問題。日本では従業員の注意に依存している部分が多いが、ヨーロッパでは設備や機械の安全性を高めることによって労災防止を図ろうとしている。実際に、ヨーロッパの印刷機械工場などにいくと、工場自体が非常に綺麗で機械自体の安全性が確保されている印象がある。

- 特別労働安全衛生改善計画、労働安全衛生改善計画策定のアドバイス

近年、安全衛生管理特別指導等事業場が匿名化されたことによって、コンサルタントの側から見て、どこが指導対象となっているのか分からなくなってきた。その理由として、個人情報保護があるのかもしれない。もっとも、神奈川支部に限定すると、コンサルタントを勧奨し、指定事業場を対象とする説明会ではコンサルタント会からの説明も一緒にさせて貰っている。

指定事業場は、労働基準監督署一カ所につき、約2～3件指定され、神奈川県には12カ所の労働基準監督署があることから、約24～36件程度あるのではないか。コンサルタント会としては、労働局や労働基準監督署が、過重労働の方に人を割いていることもあって、安全衛生担当者について人手不足となっている。コンサルタント会からの働きかけなどもあり、事業者からの依頼もある。労働局がアンケート調査を行い、指導書を出す際にコンサルタントを利用するかを聞いて、事業者が希望することで紹介がなされる場所もある。行政とコンサルタント会の協働的活動が重要である一方、事業者のコスト意識も依頼されるかどうかにおいては問題となる。

- コンサルタントの利用促進等について

コンサルタントが事業者に対して1年指導するだけでも大きく改善する。特越労働安全衛生改善計画等の策定の際のアドバイスだけではなく、より広くコンサルタントを利用する機会を増やしたら良いのと思うが、他方で、コンサルタント側の能力向上も求められる。そこで、コンサルタント会ではフォローアップ講座も行っている。

実際、コンサルタント会に依頼され、派遣したコンサルタントが会社と合わずに、交代することもある。どういう風に話ができるか、というのが能力にかかわる。売れるコンサルタントはいくらでも売れる一方、ダメなコンサルタントには仕事が来ないから、経験が蓄積されずに、ますますダメになる。コンサルタント会としても、毎月勉強会をし、弁護士講師にも来て頂いている。

- 労働安全衛生に関わる専門職との連携のあり方

社会保険労務士との連携も考えられるが、実際に、コンサルタントへの連携希望等はない。社会保険労務士は法的知識を持つものの、機械や設備については詳しくない。もっとも、社会保険労務がいなければ書類が作成できないということもあるが、これまで社会保険労務士や行政書士と組んで仕事をするということもない。

一方で、労務基準協会（東京都）や神奈川労務安全衛生協会という中災防傘下の団体については、連携している。また作業環境測定士との連携もある。産業医についても、コンサルタント会の理事や監事になっている先生もいることから連携はしているが、他方で、密接に連携しているわけでもない。産業医は現場を知らないことも多く（産業医は安全衛生委員会への出席義務はあるが、技術的側面について知識を持たない）、実際、コンサルタントである自分（森山氏）と数年一緒に巡視した産業医もいる。他の専門職と強調できるものはした方がよいのは当然である。

- その他、労働安全衛生法令について、使いづらい点や改正すべき点についての意見

労働安全衛生法そのものは、産業界の事故を減らすための細かい規定を書いている。素晴らしい法律で、法律があった裏にはそれだけ、事故・死亡者があったことを示しているもの。しかし、その繋がりがはっきり分からない。

条文数が膨大すぎて、実務上使い勝手が悪いと思う。1972年はイギリスでは、ローベンス報告もあり、法律は軽くしようと決めた年だった。日本は反対にそれから条文が膨大になっている。法律を大事にしている専門職はともかく、事業者はついていけないし、弁護士の先生で労働法の中で労働安全衛生法を詳しい人がいない。

法律で細かく決めてくれ、それだけ守れということになるのが一番ダメだ。実は、それすら守っていないのが実情で、事業者としては自分のところに適用される法律が何か分かっていない。半導体を取り扱っていると、その部分は知っているが、全体は分かっていない。また、化学物質をどういう具合に取り扱うかは分かっているものの、それ以上は自分の仕事ではないというようになっている。何のためにやるのか自分で考えていない。



実際の事例として、まじめな顧問先（食品製造業）においてこのような話があった。化学物質を主に扱う現場ではないが、賞味期限を印字するインクジェットプリンターがあり、そのプリンターヘッドを1週間に1回掃除する必要があるが取り外せないため、屋内で洗浄する。洗浄に使っているのはメチルエチルケトンであったが、使っている量からするとギリギリ有機則にひっかかる。もちろん、少量の場合は除外申請をすれば外れるが、除外申請しなければ、作業主任者の資格として、局部排気装置（100万円。毎月の点検も必要で化学工場と同様の規制がかかることに）をつけなければならない、というのが法の建前である。しかし、実際には、除外申請をやりかけて頓挫しているところ何百箇所もある。労働基準監督署の方でも基準がよく分かっていないので免除したがるというところがあるためである。そのため、コンサルタントが依頼者に提示できるのは、申請の手間やコストをかけて免除申請するか、免除申請しないとしても、行政は取り締まらないがそのまま放置するか、という選択肢となる。結果として、不法な状態で放置されることになる。あるいは、そもそも適用されることにも気付かないケースもある。結局、申請されなければ、免除はされない。少量の薬品を使っているところでは同様の問題があり、本来はメーカーが屋外で洗浄できるように取り外せるようにしてくれたらよいのにも思う。

ヨーロッパが優れているのは、労働安全衛生法を立ち上げて、すっきりした形に変え、細かく改正をしなくて良い点である。多くの事故はその当時の技術的な制約によって生じるものや時代によって解決するものが多い。しかし、法律で一旦決めると、そのまま残ってしまい、柔軟性に乏しい。結果的に、古い構造に対する規制がそのまま残ると技術の発達を妨げてしまう。結局、法律を守るのが精いっぱいになる。

EUにおいて安全の規則を一体化しなければという動きもあったが各国ばらばらになっている。ニューアプローチ指令が出され、ヨーロッパで産業機械は安全であるためには、適用される法律があり、それを充たせば、CEマーキングをつけることになっている。日本ではマークが複数存在し（SGマーク、安全玩具STマーク、電気ならPSEマーク）、複雑になっている。CEマークをとるためには、EN（ヨーロッパノルム）を充たす必要があり、法律ではなく規格を決める形を採用した。規格は法律よりも容易に変えられるからである。そして、その規格をISOにし、さらに、ISOの12100をENにした。これを取らないと域内を流通できないようにした。規格を遵守すべきことを法律で強制する形となっている。規格は5年に1回見直される。法律が守るよといっている規格が法律と違うところで進歩している。一方で、日本では、法律では守りなさいというのがないが、機械の包括的安全基準に関する指針は通達であり、ISOのドラフト版を翻訳したもので変わっていない。規格そのものを参照しろとしておけば良いのにもかかわらず、細かく法規制で対応している。安全に関して世界と同じルールで良いのではないか。

ロボットは産業用ということで工場の中で柵の中に入れて使うということになっているが、現在、ベルトコンベヤーの隣にロボットを置き、人間とロボットが同時に動けるような形、すなわち、ロボットと協働できるという方向に移行している。にもかかわらず、安

全基準を緩めようという方向がおかしいのではないだろうか。

また、指針の解釈規定でやる、というのはやりすぎではないだろうか。解釈規定が参照しているのが ISO の 10218 である。やるのであれば、世界と同じレベルにすべきではないか。他方、安衛則 107 条では、機械の停止に関する措置（鍵を閉める。※OSHA を参照したもの）について指針が出たが、現場の事業者から反対もあって、指針をやめたという経緯もある。機械には鍵かけるようになっていないなどの説明をされたが、鍵はついていなくても、鍵をかける方法は実際にはある。そのような形で閉めることもできたはず。どうせやるなら、こういった簡単な機械を使うことを義務付けるべきなのではないだろうか（参考写真参照）。例えば、この鍵を持っていないと現場に入れないようになっている企業があるし、名札のところにこの鍵を置いていけば、確認もできるような形になっている。

- 最後に

現在、一般社団法人安全技術普及会による機械安全講習会の活動も行っており、年に数回講習会を行っており、機械安全の向上の機会を用意している。また、安全工学会においても倫理教育を行っており、その中で、技術者倫理として、新しいものは基本的には「危険」であることから、「技術」で抑え込むという発想を知るべきであると伝えている。設計システムを単に覚えるだけではないことが重要である。

(参考写真)

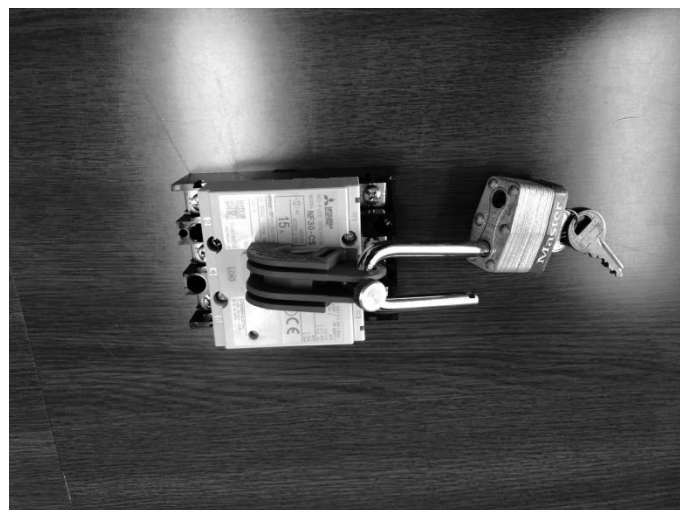
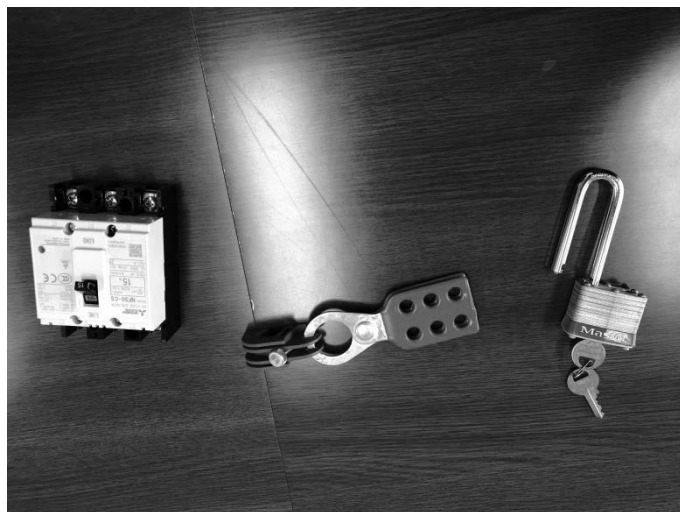

## <ヒアリング調査の概要②>

日時・場所：2020年3月18日13時半～14時半@中央労働災害防止協会本部9階

ヒアリング対象者：後藤博俊（一般社団法人日本労働安全衛生コンサルタント会顧問、労働省環境改善室長等歴任）

ヒアリング実施者：石崎由希子（横浜国立大学准教授）、南健悟（日本大学准教授）、三柴丈典（近畿大学教授）

## <ヒアリング内容の概要>

### 1 コンサルタントについて

・コンサルタントとして新規に業務の依頼を受ける経緯としては、安全衛生管理特別指導事業場に指定されたタイミングで受けることが多い。従来は、指定の際にコンサルタント会の各支部に話がいき、そこでクライアントを作ることが多かった。しかし、民主党政権になった頃から、一覧表が示されなくなった。ただし、労働局長は特別安全衛生改善計画の作成にあたり、コンサルタントの意見を聴くべきことを勧奨できることとの関係で、少なくとも東京労働局では、指定書の下の方にコンサルタントの勧奨を受けることを指導する旨を記載している。そのため、指導を受けた会社はこれを契機として個々のコンサルタントに連絡してくることもある。

・各企業が本部又は支部に依頼してくるケースもある。東京支部であれば毎年100件程度である。会員にメールで連絡し、希望者の中から、能力・適性を踏まえた上で案件を割り振るようにしている。コンサルタント会では倫理規程があり、自信がない領域について受けないようと言っているが、ミスマッチもある。1つの分野の中でも、更に専門領域に分かれるため、的確なマッチングは難しい。

・かつて沼野雄志先生（（一社）日本労働安全衛生コンサルタント会会長、（公社）日本作業環境測定協会常任理事等歴任）は、登録時研修で、工場前をうろうろして何をしている会社か、どのような安全衛生問題があるかを推察して、営業をかけるように仰っていた（が、現にそうしている人は多くない）。

・コンサルタントのうち7割以上は独立している。また、定年後の人も多い。かつて、土木分野では在職中の人が多かったが、既に退職している。保健衛生に登録している者のほとんどは医師である（医師は面接だけで資格を取得できる）。土木と建築は1級施工管理技士が受けに来ることが多い。

・試験時に選択しなかった領域の助言に携わることもある。例えば、労働衛生工学で登録しても頼まれることの多くは安全にかかわることである。

・工学を選択した者の中の半数以上は作業環境測定士も兼ねている。測定士は試験科目の一部免除があることも影響している。測定士試験の関連法令は衛生管理士の試験よりも易しいのではないかとの印象がある。そこで、測定士試験に合格して、その後、コン



サルの試験を受けるということがある。

- ・作業環境測定士を在職中にやっていて、その後その分野でコンサルタントになったら、労働衛生コンサルタントの資格をとって仕事の幅を拓けようという者も多い。コンサルタント個人で高額の測定機器を容易できないということもある。

- ・測定士自身が事実上コンサルタントの活動をしている場合もあるが、あまり多くない。オキュペイショナルハイジニストの制度が創設されたことは、良いことだとは思いますが、一部の熱意ある人に支えられているという印象である。

- ・労災の多い企業の共通点はトップの意識が低いということ。トップの意識で変わる部分がある。例えば、従業員がヒヤリハットの提案を目安箱に出したら、鉛筆を1本あげると、という仕組みで無災害を達成しているところもある。

## 2 作業環境測定について

- ・四アルキル則はやや特異な経緯でできたが、有機則・鉛則の制定に際しては相当綿密な調査をし、作業列举方式で規制した。労働衛生を進めるのは、作業列举方式であるとの共通した認識があった。特化則は公害問題等、社会の必要に応じて緊急的に策定したという面がある。新宿柳町の公害問題への対応ということでガソリンを無鉛化する代わりに、オクタン値を下げるため、ベンゼンを入れることにしたが、このベンゼンが特化則の規制対象となったことで、ガソリンの給油の人もこの規制の対象に含まれることになってしまった。当時は、特化則の適用除外（2条の2）の規定もなかった。

- ・各特別則を統合しようかという考えがなかった訳ではないが、実際には各則ごとに運用がなされており難しかった。また、統一してしまうと、特化則のような粗い規制に統合されてしまうという懸念があった。

- ・石綿則が分かれたのは、石綿には建築の解体などで発散するなどの特徴があり、特化則の中できめ細やかな規制をすることは難しかったためである。

- ・特殊健診では、エチレンオキシド、ホルムアルデヒドを製造する業務は職業がん専門家（会議）委員会で勧告されて作業環境測定の対象となっているが、健診項目がはっきりしなかったため特殊健診の対象外とされているのではないかと思われる。

- ・コークス炉上若しくはコークス炉に接してコークス製造の作業を行う場合の当該作業場が作業環境測定・健康管理手帳の対象となっているが、特殊健診の対象外となっている理由がよく分からない。

- ・鉛業務において、鉛装置の内部の業務やゴム若しくは合成樹脂の製品、含鉛塗料又は鉛化合物を含有する絵具、釉（ゆう）薬、農薬、ガラス、接着剤等を製造する工程における鉛等の溶融、鑄込、粉碎、混合若しくはふるい分け又は被鉛若しくは剥（はく）鉛の業務等が作業環境測定の対象外とされているのは、あまり発散しないためであるが、それと共に、検知管方式ではない測定の負担が重いことも影響している。そのため、鉛については年1回とされている。（なお、検知管方式での測定が求められていた当時は年4回の測定とされていた）。

・都道府県労働局長による作業環境測定の実施その他必要な事項の指示（安衛法 65 条 5 項）は健診の命令に合わせて作られたものであるが運用されていない。

・作業環境測定指針は策定されていない（安衛法 65 条 3 項）。これについて、役所の怠慢ではとの批判がされたこともあるが、指針として策定してしまうと科学技術の進歩を妨げるという面から策定されていない。作業環境測定基準において、「同等以上」の測定方法を認めているのは、科学技術の進歩によりより良い方法が出てくることが考えられるから。国の委員会を作って「指針」を作成しようとしたこともあるが、どこからが基準でどこからかマニュアルかはっきりしないこともあり、実現しなかった。

### 3. その他（労働安全衛生法令全般について）

・今後、自主管理進んでいくのではないかと思う。

・かつて安衛法の神様と言われた寺西検事（訟務検事）に言わせれば、「労働安全衛生規則は皆、ガイドラインだ」ということ。「お前のところは葬式送検だから、略式だから（できる）。正式裁判だったら起訴猶予だぞ。」と言われた。安衛法には災害が発生する「おそれがある」場合に措置を講じねばならない等の規定があるが、災害を発生させてしまった事業者も、通常、その「おそれがある」と思っていたわけではない。なので、厳格に罪刑法定主義が問われ、故意性が求められる刑事の正式裁判では持たない。

・特化則では、がん原性物質について、記録の 30 年保存を求めている。この規定は、「しなければならない」ではなく「ものとする」とある。これについては、議論をしたことを覚えている。というのは、30 年保存といったところで、30 年先に保存していないことが分かったとして、誰を処罰するのか。担当者は生きてすらいないのではないか、ということが問題となったからである。処罰の対象がいらないなら「努める」で良いのではとの議論もあったが、「ものとする」とすることで落ち着いた。これは、読む人によって、義務規定とも訓示規定とも読める。

・努力義務と罰則付きでない強行規定の違いについて尋ねられることもある。安全配慮義務違反等の民事過失責任の判断の際に考慮される程度が変わってくるとしか答えようがない。

・安全衛生関連法令については、ルールを分かりやすくし、国民に知らしめるということが重要（だが、難しい）。労働安全衛生法はともかく、特別則はもう少し分かりやすくできないかと思う。特化則 5・6 条や石綿など。

・また、リスクアセスメントと言いながら、化学物質以外は看過されているように思う。第 3 次産業の災害防止も重要である。

・コンサルタントの活動領域の拡大という観点からは、計画の届出の場面というよりも、規制の免除の場面で関与させ、関与していたらノーチェックで通すなどの仕組みも考えられる。



#### IV. 研究成果刊行物一覧

\* 研究計画の終了後に体系書を発刊予定。





- 1.大藪俊之. 職場の安全衛生管理に関する規制の実効性確保—労働安全衛生法の場合—. 佛  
教大学社会学部論集第 70,1-18,2020
- 2.三柴丈典. 副業・兼業者、フリーランスに対する安全衛生法政策に関する試論. 労働法学  
研究会報 71(21),4-31,2020



論文

## 職場の安全衛生管理に関する規制の実効性確保

——労働安全衛生法の場合——

大藪 俊 志

〔抄 録〕

本論文では、労働安全衛生法に基づく職場の安全衛生管理に関する規制の執行活動を対象として、規制の実効性確保の仕組みと構造を検討する。規制の分類からみた場合、職場の安全衛生管理に関する規制は社会的規制の範疇に含まれるが、労働災害の防止と労働者の健康と安全の確保という規制の目的を達成するため、主として特定行為の禁止、資格制度、検査検定制度、基準・認証制度などの手段を用い、物的規制（製造・流通段階と使用段階における機械・器具その他の設備、原材料、建設物、作業環境の安全・衛生の確保）、作業規制（作業自体の安全の確保）、人的規制（安全衛生教育、免許・技能講習などの就業制限による作業従事者の能力を担保）を実施している。また、規制の実効性を確保するため、労働災害防止計画制度、労働者に対する知識の付与（情報提供）、労働者の参加の保障と促進、労働基準監督制度、安全衛生改善計画・特別安全衛生改善計画、労働安全コンサルタント・労働衛生コンサルタントなどの手段を用い労働災害の低減に努めてきた。この他、中央労働災害防止協会などの労働災害防止団体による災害防止活動が、国（行政）が行う監督指導等と相まって事業主による自主的な災害防止活動を促進する体制を構築している。

キーワード：公的規制，社会的規制，規制行政，規制の実効性確保，労働安全衛生法

### はじめに

本論文の目的は、労働安全衛生法（以下「安衛法」という。）に基づく職場の安全衛生管理に関する規制の執行活動を対象として、規制の実効性確保の仕組みと構造を検討することにある。給付行政とともに行政活動の大部分を占める規制行政に関しては、既に経済学、法学、行



政学などの観点から数多くの研究がなされており、本稿で取り上げる社会的規制の分野に関しても、規制の理論・体系、規制の手段、規制の経済分析、規制改革などの論点に関する研究が積み重ねられている<sup>(1)</sup>。また、規制の実効性確保という論点に関しては、近年、土地利用規制、建築規制などの分野において多くの事例研究がみられる<sup>(2)</sup>。このような先行研究に対し、本稿は職場の安全衛生管理に関する規制の執行活動という比較的狭い領域を対象とした研究となるが、限られた行政資源のもと様々な規制手段を駆使することにより、人々が社会生活を送るうえで重大なリスクとなる労働災害の低減に取り組む行政活動を検討することにより、規制行政のより詳細な実態把握に貢献することとしたい。

以下、本稿の第1節では、公的規制の概要、規制の実効性を確保するための法的な仕組み、具体的な規制の手段などを検討する。続く第2節では、本稿が具体的な検討の対象とする職場の安全衛生管理に関する規制に関わる法令の体系と規制の実効性確保の仕組みと構造を分析する。また第3節では、規制の実効性確保の実態に関し、労働災害の低減に向けた労働基準監督制度に基づく監督指導等の状況、労働災害防止団体の取組みに注目する。そのうえで、職場の労働安全衛生管理に関する規制の実効性確保の取組みと特徴、労働災害の現状と課題をまとめ、本稿の総括とする。

## 1. 公的規制と規制の実効性確保

〔公的規制〕

「特定の社会を構成する私人、ないし特定の経済を構成する経済主体の行動を、一定の規律をもって、規制する行為」としての規制は、規制を実施する主体により公的規制（公的機関による規制）と私的規制（私人による規制）に分類される（植草 2000：1）。このうち公的規制は、「不完全競争、自然独占性、外部性、公共財、非価値材、情報の非対称性等の市場の失敗に対処する目的で、政府が法的権限をもって経済主体の行動を規制するもの」と理解される（植草 1997：6）。公的規制を広く解する場合、間接規制（政府が設定した経済主体の行動に係るルール違反に対する事後的な規制）、直接規制（経済主体が意思決定を行う段階における許認可型の規制）、誘導型規制（課税、補助金など経済的手段による規制）、誘引型規制（ヤードスティック規制、排出権規制など）が含まれる（植草 1997：6-7）。

また、狭義の公的規制とは直接規制を意味するものであり、その目的に応じて経済的規制と社会的規制に分類されることがある<sup>(3)</sup>。このうち経済的規制とは、「自然独占や情報偏在が存在する分野において資源配分非効率の発生の防止と利用者の公平利用の確保を目的として、企業の参入・退出、価格、サービスの量と質、投資、財務・会計等の行動を許認可等の手段によって規制」することであり、具体的には公益産業（電気、ガス、水道など）、通信・放送、運輸、金融、製造業、建設業、流通などの産業を対象として、参入規制や料金規制を実施する（植草

2000: 24, 36)。

この経済的規制に対し、本稿が検討の対象とする職場の安全衛生管理に関する規制は社会的規制の範疇に含まれる。一般に社会的規制とは、「外部性、公共財、情報の非対称性、リスク等によって資源配分効率が歪められ、社会秩序の維持と社会経済の安定性が損なわれる場合に、これを防止することを目的とし、特に国民の健康・安全の確保、環境の保全・災害の防止」を主題とする規制と理解される(植草1997: 8-9)。これを広く解すると、社会的規制の範囲には国土・土地・建物、雇用・労働、教育・文化などの分野が含まれ(経済改革研究会1993)、中核的な分野を取り上げれば、①健康・衛生の確保(公衆衛生・医療、環境衛生の確保、麻薬等の規制)、②安全の確保(自然災害の防止、産業災害・労働災害の防止、交通事故・火災事故の防止、製品・サービスの事故の防止)、③公害防止・環境保全(公害防止、廃棄物処理、環境保全)などがその対象範囲となる(植草1997: 13)<sup>(4)</sup>。

〔規制の実効性を確保するための法的仕組み〕

公的規制に関わる行政活動は規制行政に分類される<sup>(5)</sup>。規制行政とは、「土地利用規制、営業規制のように、私人の権利自由に対して制限を加える行政活動であり、それ自体が直接に公益の実現に寄与する」行政活動を指す(宇賀2017: 83)。規制行政のプロセスの基本的骨格は、①法律(国民の代表である議会が制定した法律に基づく行政活動の実施。委任立法を含む。)、②行政処分(法令により定められた一般的・抽象的権利義務を具体化し、個別の国民に具体的な権利義務を生じさせる。)、③行政強制(行政処分で課された義務に相手方が従わない場合、裁判所の力を借りずに行政庁が自力で行政執行を行う。)の3段階から構成される(藤田2013: 20, 中原2018: 88-90)。

規制行政における法的仕組みには、許可制、認可制などがある。許可制とは、「ある種の国民の活動を一般的に禁止したうえで、国民からの申請に基づき審査を行い、一定の要件に合致する場合、禁止を個別具体的に解除する」法的仕組みであり、認可制は、「法律行為の内容を行政庁が個別に審査し、当該行政庁が効力を発生させる意思表示が法律行為の効力を補充して効力を完成させる」法的仕組みを指す(宇賀2017: 86-93, 93-95)。この他にも、規制行政における主な法的仕組みとして、届出制(国民がある行動をとる前後に行政機関への届出を義務付ける)、下命制(国民に対し一定の作為を命じる)、禁止制(国民に対し不作為を命じる)などが挙げられる(宇賀2017: 102-105)。また、行政上の義務の実効性を確保する方法には、義務の履行を強制する仕組みと、義務違反に対する制裁を通じて義務履行を促す仕組みがある(宇賀2017: 219-272, 高橋2018: 166-194)。義務の履行を強制するためには、法律の根拠がある場合にのみ認められる行政上の強制執行(代執行、強制徴収など)と民事手続による強制の方法があり、義務違反に対する制裁としては、刑罰、過料、課徴金、制裁的公表などの方法がある(中原2018: 214-228)。

〔社会的規制の具体的な手段〕

公的規制のうち、職場の安全衛生管理に関する規制も含まれる社会的規制の具体的な手段をみると、直接規制には、許可制・認可制などの法的仕組みのもと、①特定行為の禁止・営業活動の制限、②資格制度、③検査検定制度、④基準・認証制度、⑤その他の方法による規制手段が存在する（井出 1997：51）。こうした規制手段のうち、①特定行為の禁止・営業活動の制限は、強い規制（許可、認可、免許、承認、指定、承諾など一般的な禁止を特定の場合に解除し、特定の権利などを設定する行為）、中間の規制（認定、確認、証明、認証、試験、検査、検定、登録、審査など特定の事実や行為が設定された基準を満たしている否かを審査・判定、公の証明を行う行為）、弱い規制（届出、提出、報告、交付、申告など、一定の事実を行政庁が確認して受理する行為）に分類される（井出 1997：51-54）。②資格制度は、「製品等の物的なものに結びついた技術ではなく、消費者や企業に対して一定の役務を提供する者自体の有する技能水準を、公的に確認・保証するための仕組み」を意味する（八代・伊藤 2000：250-251）。資格制度には、業務独占資格（有資格者以外の業務への従事を禁止する）、業務必置資格（業務に係る有資格者を置くことを事業者に義務付ける）、名称資格（一定の基準を満たしていることを公証することで有資格者の資質の向上を図る）の類型が存在する（臨時行政改革推進審議会事務局 1989, 井出 1997：54-62）。③検査検定制度は、製品などの品質保持、生活の安全、取引の適正化などの目的のもとに、定期検査、使用前検査、使用后検査などを事業者に義務付ける制度である（井出 1997：62）。出荷する製品自体の検査を行う制度以外に、製品の設計段階のみ行政庁が検査・確認を行う（製造は事業者の責任により行われる）形式承認制度も含まれる（八代・伊藤 2000：250）。④基準・認証制度は、「製品の安全性、設備の操業・管理の安全性を確保する観点から、それらの安全基準を定め、これに合致している旨のマークをつけたもの、ないしはその検定を受けたものでなければ、販売・利用を禁止する」制度である（井出 1997：62-67）。守られるべき技術的水準を定めるものが基準（technical regulation）であるのに対し、基準に適合することを確認する方法・手続を法令等に規定する制度が認証（certification）であり、後者には行政が行う認証以外に事業者自身が行う自己確認や第三者による適合性評価（conformity assessment）も含まれる（八代・伊藤 2000：249-250）。⑤その他の方法による規制には、契約、協定（代表例として公害防止協定など）、申し合わせ、行政指導などがある（井出 1997：67-71）。

直接規制以外の社会的規制の手段としては、間接規制、誘導型規制と誘引型規制、情報公開などが挙げられる。間接規制の代表的な事例としては水質汚濁防止法や大気汚染防止法などに基づく規制システムがあり、基準+届出+立ち入り検査+罰則、損害賠償という組み合わせが用いられる（井出 1997：71-72）。また、誘導型規制は課徴金や補助金などの制度、誘引型規制は排出権取引制度やデポジット制度などの経済的手段を用いることにより、規制の目的の達成を目指すものであり、情報公開では、事業者が供給する財・サービスの情報開示、不当表示の

禁止などの取組みを通じて、市場の失敗である情報の不完全性（非対称性）に対応することを意図している（井出1997：72-79）。

〔規制の実効性を確保するための行政活動〕

政策のプロセスからみた場合、行政が規制の実効性を確保する取組みは政策の執行（実施）の段階に当たる。規制の執行活動は、①基準設定の段階：抽象的・一般的な法令を具体化したうえで執行するための枠組み・行動基準を作成するプロセス、②方針決定の段階：一定の時期・範囲において有限な資源を執行すべき活動内容を決定するプロセス、③基準適用：決定された基準・方針に基づき個別の規制対象の行動を制御するプロセスの3段階に分類される（森田2017：172-173）。この執行活動には、適法性、有効性、効率性という要件が求められるが、他方で、①法的制約：法令に規制の実効性を確保するために必要な権限が規定されていない場合など、②予算・資源の制約：規制の執行活動に必要な行政資源（ヒト・モノ・カネ）が不足している場合、③社会状況の複雑さと流動性：社会経済情勢の急速な変化が執行活動を制約する場合、④規制対象者の利己的行動という制約：規制の執行を回避しようとする対象が多数存在する場合なども考慮しなければならない（森田2017：175-176）。

そこで規制行政の執行活動に際しては、①善意の違反者（規制のルールを知らずに違反した対象者）に対しては規制内容の周知、②利己的な動機により規制を回避しようとする違反者に対しては罰則に基づく制裁措置、③確信的にルールに反抗する違反者（異議申立者）に対しては適応戦略（違反行為の黙認、制裁措置からの適用の除外）などの対応をとるなど、違反行為の類型（動機）やリスクに応じた規制の執行方法が柔軟に選択されることになる（西尾2000：34-43）。

## 2. 職場の安全衛生管理に関する規制

〔職場の安全衛生管理に関する法令〕

職場の安全衛生管理に関する規制は安衛法を中核とする法令に基づき実施される<sup>6)</sup>。安衛法は、総則（第1条～第5条）、労働災害防止計画（第6条～第9条）、安全衛生管理体制（第10条～第19条の3）、労働者の危険又は健康障害を防止するための措置（第20条～第36条）、機械等並びに危険物及び有害物に関する規制（第37条～第58条）、労働者の就業に当たっての措置（第59条～第63条）、健康の保持増進のための措置（第64条～第71条）、快適な職場環境形成のための措置（第71条の2～第71条の4）、免許等（第72条～第77条）、事業場の安全又は衛生に関する改善指導等（第78条～第87条）、監督等（第88条～第100条）、雑則（第101条～第115条）、罰則（第115条の2～第123条）により構成される。

また、安衛法を中核とする法令の体系は、2本の政令（労働安全衛生法施行令、労働安全衛生法関係手数料令）、3本の特定機械等に係る特別安全衛生規則（ボイラー及び圧力容器安全



規則、クレーン等安全規則、ゴンドラ安全規則）、11本の特別衛生規則（有機溶剤中毒予防規則、鉛中毒予防規則、四アルキル鉛中毒予防規則、特定化学物質障害予防規則、高気圧作業安全衛生規則、電離放射線障害防止規則、酸素欠乏症等防止規則、事務所衛生基準規則、粉じん障害防止規則、石綿障害予防規則、除染業務等に係る電離放射線障害防止規則）、その他3本の省令（労働安全衛生法及びこれに基づく命令に係る登録及び指定に関する省令、機械等検定規則、労働安全コンサルタント及び労働衛生コンサルタント規則）により構成される。

〔安衛法を中核とする法令による規制〕

安衛法の目的は、同法第1条「労働災害の防止のための危害防止基準の確立、責任体制の明確化及び自主的活動の促進の措置を講ずる等その防止に関する総合的計画的な対策を推進することにより職場における労働者の安全と健康を確保するとともに、快適な職場環境の形成を促進すること」と規定されているように、「労働災害の防止」と「労働者の安全と健康の確保」にある<sup>(7)</sup>。このような目的を達成するため、安衛法では主に特定行為の禁止、資格制度、検査検定制度、基準・認証制度などの手段を用い、①物的規制（製造・流通段階と使用段階において、機械・器具その他の設備、原材料、建設物、作業環境の安全・衛生の確保を図る）、②作業規制（作業自体の安全の確保を図る）、③人的規制（安全衛生教育、免許・技能講習など就業制限による作業従事者の能力を担保する）を実施している（畠中 2019：50-51）。

具体的な規制の事例の一部を取り上げると、①物的規制では、特に危険な作業を必要とする機械（ボイラー、第一種圧力容器、一定のクレーン・デリック・エレベーター、ガイドレール、ゴンドラなど）を対象とする製造許可制度が定められている（安衛法第37条）。②作業規制では、例えばクレーンを使用する作業を対象として、玉掛け作業、荷を吊った状態での運転位置からの離脱の禁止、外れ止め装置の使用、過負荷・傾斜角の制限、定格荷重の表示等、搭乗の制限、つり荷の下への立ち入り禁止など安全作業に必要な規制が実施されている（クレーン等安全規則）。③人的規制では、一定の危険な作業を伴う業務（ボイラー・第一種圧力容器に係る業務、クレーン・デリック・フォークリフトの運転など）を就業制限業務に指定し、有資格者以外の就業を禁止したうえで（安衛法第61条）、当該業務に係る免許と技能講習の制度を規定（安衛法第72条～第77条）している。

安衛法に基づく規制の主たる義務主体は事業者（事業を行う者で、労働者を使用するものをいう（安衛法第2条第3号））であるが、機械等・危険物・有害物の製造や流通に対する規制、請負、リース業、労働者派遣事業に係る規制では事業者以外も義務主体となる<sup>(8)</sup>（畠中 2019：60-67）。

〔職場の安全衛生管理に関する規制の実効性確保の仕組み〕

職場の安全衛生管理に関する規制は、事業者などの義務主体が法定の労働安全衛生に関する最低基準を自主的に遵守することを前提としている。そのうえで規制の実効性を確保するため、(1) 労働災害防止計画、(2) 労働者に対する知識の付与（情報提供）、労働者の参加の保障と

促進, (3) 労働基準監督制度 (罰則・送検処分を含む), (4) 一般の安全衛生改善計画・特別安全衛生改善計画, (5) 労働安全コンサルタント・労働衛生コンサルタントなどの規制手段が用いられている (畠中 2019: 86)。

以下, それぞれの手段を具体的にみると, (1) 労働災害防止計画は, 厚生労働大臣が策定する「労働災害の防止のための主要な対策に関する事項その他労働災害の防止に関し重要な事項を定めた計画」(安衛法第6条)である。その目的は, 労働災害の防止に関する主要な施策, 重点を置くべき業種及び労働災害の種類と労働災害の減少目標などを定め, 国 (行政) が具体的な施策を講ずるとともに事業者, 労働者などの関係者に周知することにより, 官民一体となって労働災害の防止対策を総合的・計画的に推進することにある (労務行政研究所 2017: 215-220)。

労働災害の防止に関する国の計画は, 「産業災害防止5か年計画 (第1次)」(1958年策定) に始まり, 「労働災害防止団体に関する法律」(1964年制定) に基づく「労働災害防止基本計画」(5年ごとに策定) と「労働災害防止実施計画」(毎年策定) を経て, 現行の「労働災害防止団体会法」(1972年制定) に基づく「労働災害防止計画」が5年ごとに策定され, 実施されている (労働調査会 2015: 213-217)。

労働災害防止計画の具体的な内容をみると, 「第13次労働災害防止計画」(計画期間: 2018年度~2022年度) では, 重点事項として, ①死亡災害の撲滅を目指した対策の推進, ②過労死の防止など労働者の健康確保対策の推進, ③就業構造の変化及び働き方の多様化に対応した対策の推進, ④疾病を抱える労働者の健康確保対策の推進, ⑤化学物質などによる健康障害防止対策の推進, ⑥企業・業界単位での安全衛生の取組みの強化, ⑦安全衛生管理組織の強化及び人材育成の推進, ⑧国民全体の安全・健康意識の高揚などを掲げている (厚生労働省 2018b)。さらに重点事項ごとの取組みとして, 例えば, ①死亡災害の撲滅を目指した対策の推進では, 業種別・災害種別の重点対策分野として, 建設業における墜落・転落災害などの防止, 製造業における施設, 設備, 機械などに起因する災害の防止, 林業における伐木などの作業の安全対策を取り上げ, 目標数値 (建設業の場合は労働災害による死者数を2022年までに15%以上減少させることを目標とする) を示したうえで, 墜落防止用保護具 (フルハーネス型の安全帯) の使用の徹底, 2020年東京オリンピック・パラリンピック競技大会に関連する施設工事における労働災害防止対策の徹底 (長時間労働の縮減を含む) など, 個別具体的な取組みを事業者などの関係者に求めている<sup>9)</sup> (厚生労働省 2018a)。

この労働災害防止計画に関し, 厚生労働大臣は, 労働災害の発生状況, 労働災害の防止に関する対策の効果などを考慮して必要があると認めるときは, 労働政策審議会の意見を聞いて, 計画を変更しなければならない (安衛法第7条)。また, 厚生労働大臣は, 労働災害防止計画の的確・円滑な実施のため必要があると認めるときは, 事業者, 事業者の団体のその他の関係者に対し, 労働災害の防止に関する事項について必要な勧告をすることができる (安衛法第9

条)。

(2) 労働者への知識の付与（情報提供）、労働者の参加の保障と促進は、職場の安全衛生管理の問題に日常的に接している労働者が自発的に労働災害防止対策を講じ、併せて事業者が実効性のある対策を講じるために必要不可欠な取組みとして重視される（畠中 2019：87-88）。労働者への知識の付与（情報提供）に係る主な取組みには、安全衛生教育（安衛法第 59 条）、法令等の周知義務（安衛法第 101 条）、危険物・有害物の表示義務（安衛法第 57 条）などがある。具体的にみると、安全衛生教育では、労働者を雇い入れた場合、作業内容を変更した場合、一定の危険有害業務に就かせる場合に、客観的に業務に必要と認められる教育を事業者が労働者に対して行うことを義務付けている（労働調査会 2015：688-706）（労務行政研究所 2017：549-566）。法令等の周知義務では、安衛法を中核とする各種法令（労働安全衛生規則など）に関し、作業内容、作業態様などを勘案して労働者に分かりやすい内容にまとめたうえで掲示する（備え付ける）ことや、作業で取り扱う物質の成分、有害性、注意事項などを労働者に周知することが事業者に対して義務付けられている（労働調査会 2015：996-999）（労務行政研究所 2017：841-844）。危険物・有害物の表示義務では、爆発性の物、発火性の物、引火性の物、ベンゼン、ベンゼンを含有する製剤などの表示制度を定めることにより、爆発火災や職業性中毒などを防ぐことを目的としている（労働調査会 2015：653-661）（労務行政研究所 2017：514-525）。

また、労働者の参加の保障と促進に関しては、法令が定める規制の自主的な履行確保組織として事業場に構築が義務付けられる安全衛生管理体制（総括安全衛生管理者、安全管理者、衛生管理者、安全衛生推進者、産業医など）のなかでも、とりわけ職場の安全衛生に係る審議機関（安全委員会、衛生委員会、安全衛生委員会など）が行う調査審議、労働者からの意見聴取、事業者に対する意見の申出がその役割を果たしている（安衛法第 10 条～第 19 条の 3）（畠中 2019：92, 119-169）。

(3) 労働基準監督制度は、労働基準法（以下「労基法」という。）に基づき設置される監督機関の組織であり、労基法や関連法令の施行に関する事務とともに安衛法の施行に関する事務をも担う（安衛法第 90 条）<sup>(10)</sup>。安衛法第 10 章では、工事計画の届出と一定の場合における厚生労働大臣の審査（安衛法第 88 条・第 89 条）、労働基準監督官の権限（安衛法第 91 条・第 92 条）、産業安全衛生専門官及び労働衛生専門官の権限（安衛法第 93 条・第 94 条）、労働衛生指導医の職務（安衛法第 95 条）、厚生労働大臣及び都道府県労働局長の権限（安衛法第 96 条）、労働者の申告（安衛法第 97 条）、都道府県労働局長等の使用停止等命令及び緊急措置命令（安衛法第 98 条・第 99 条）、事業者の報告等（安衛法第 100 条）など、同法を施行するために必要な事項をそれぞれ規定している。

労働基準監督制度の組織は、厚生労働大臣の下に置かれる厚生労働省労働基準局（労働基準に関する法令の制定・改廃、労働基準監督官の任免、関係政策の企画・立案、都道府県労働局の指揮監督などを担う）と、47 都道府県に設置される都道府県労働局（管内の労働基準監督

署の指揮・監督、監督方法の調整などを担う)、321か所に置かれる労働基準監督署(関係法令の実施に関する事務、臨検、尋問、許可、認定、審査、仲裁など第一線機関としての役割を担う)により構成される(労基法第99条)。

このような監督機関の主な役割の一つに、行政的監督手法(立入検査など)による法令違反の発見と迅速な是正の実現がある(畠中2019:59)。そのため、監督機関に配置された労働基準監督官には、安衛法を施行するため必要があると認めるときは、事業場に立ち入り、関係者に質問し、帳簿、書類その他の物件を検査し、作業環境測定を行い、検査に必要な限度において無償で製品、原材料若しくは器具を収去することができる(安衛法第91条第1項)。

この監督指導業務には、定期監督(年間計画に基づいて選定された事業場に立ち入る検査)、申告監督(労働者からの申告に基づき実施される)、災害調査(労働災害が発生した場合の調査と再発防止の指導)のパターンが存在する(図1参照)。



図1 監督指導業務の概要

(出典) 厚生労働省(2019)「労働基準監督官採用試験」(file:///C:/Users/ANA21/Documents/2019\_kantokukan\_pamphlet.pdf)。

監督指導に際し法令違反が認められる場合にはその是正が事業者に対し求められ(是正勧告など)、重大・悪質な法令違反などに対しては、後述の司法処分(送検)が行われることもある。

また、法令の定める危害防止措置基準に違反している事実が認められる場合には、都道府県労働局長・労働基準監督署長は、違反した事業者、注文者、機械等の貸与者、建築物の貸与者

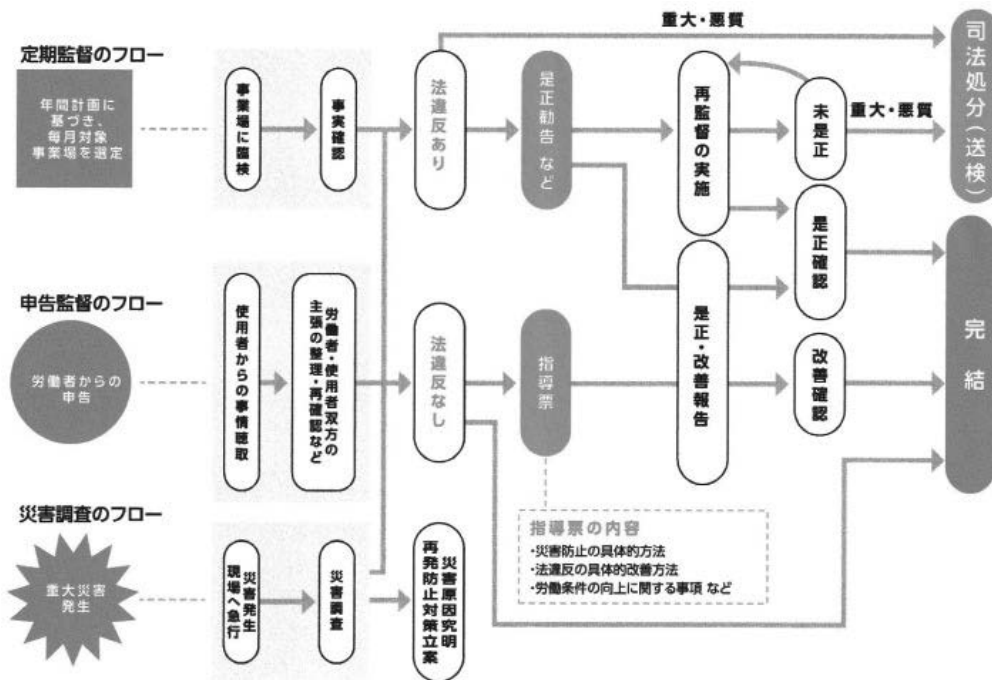

に対して、作業の全部又は一部の停止、建設物等の全部又は一部の使用停止、変更など必要な事項を命じることができる（安衛法第98条）。この規定は、事後的に刑罰権の行使により処罰するだけでなく、危険な法令違反の状態を早急に解消することにより、労働災害の発生を未然に防止することを意図したものである（労働調査会2015：977-981）（労務行政研究所2017：824-827）。また、法令違反の事実が認められない場合においても、労働災害発生の急迫した危険があり、かつ緊急の必要がある場合には、災害の発生を未然に防止するために、都道府県労働局長又は労働基準監督署長は、事業者に対し、作業の全部又は一部の停止、建設物等の全部又は一部の使用停止、その他応急の措置を講ずることを命じることができる（安衛法第99条）。

この他、監督機関が実施する労働安全衛生分野の重要な業務に工事計画等の届出制度がある（安衛法第88条・第89条・第89条の2）。この制度は、事業者に対し、危険な機械等を設置・移転する場合、大規模な建設工事を行う場合、一定の建設工事を行う場合において、工事計画等を事前に届け出ることを義務付け、監督機関（労働基準監督署長など）が審査を行い、必要と認められる場合には工事などの差し止めや計画の変更を命じる仕組みであり、既に設置された工場・設備などを事後に検査する監督指導業務（臨検監督ともいう）と対比して、事前審査・事前監督とも称される（畠中2019：101-104）。

さらに監督機関（都道府県労働局長）は、労働災害が発生した場合において再発を防止するために必要があると認めるときは、労働災害を発生させた事業者に対し当該事業場の労働災害防止業務従事者（総括安全衛生管理者など）を指定の講習を受講させることを指示することができる（安衛法第99条の2）。同様に都道府県労働局長は、法令に違反して労働災害を発生させた就業制限業務従事者に対しても、労働災害の発生を防止するために指定された講習を受けよう指示することができる（安衛法第99条の3）。また、厚生労働大臣、都道府県労働局長、労働基準監督署長は、法令の施行に必要があると認める場合は、事業者、労働者、機械等貸与者、建設物貸与者、コンサルタント（後述）に対し、必要な事項を報告させ出頭を命じることができる（安衛法第100条）。

罰則・送検処分のうち罰則は、法令に基づく規制の履行を最終的に担保するものであり、労働安全衛生法では、安全衛生管理体制、労働者の危険又は健康障害を防止するための措置、機械等並びに危険物及び有害物に関する規制、労働者の就業に当たっての措置、健康の保持増進のための措置などの各規定に罰則が設けられている。罰則に関しては、法に違反した行為者（使用者）と法人そのものを罰する安衛法第122条の両罰規定が重要な役割を果たしている（畠中2019：115-116）。例えば危険物・有害物の表示義務（安衛法第57条）を怠った場合には、使用者と法人の双方が6月以下の懲役又は50万円以下の罰金に処されることになる（安衛法第119条）。また、送検処分に関しては、特別の知識経験を有する労働基準監督官が、労働安全衛生法の規定に違反する罪について、刑事訴訟法の規定に基づく特別司法警察職員としての職務を行う（安衛法第92条）（労働調査会2015：962-963）（労務行政研究所2017：812-813）。

(4) 一般の安全衛生改善計画・特別安全衛生改善計画のうち、一般の安全衛生改善計画は、労働災害の的確な防止のため総合的な改善措置を講ずることが適切とされる事業場に対し、都道府県労働局長が作成を指示するものである（安衛法第79条第1項）。この安全衛生計画には、事業場が良好な安全衛生の状態に到達するための具体的な改善手法が記載され、具体的な事項としては機械・設備装置などの改修、代替、新設などの措置、有害物に係る機械、設備、建物、施設に関する措置、作業標準の設定と実施のための訓練の方策などがある（労働調査会2015：907-909）（労務行政研究所2017：759-761）。

また、特別安全衛生改善計画は、法令違反に起因する重大な労働災害（死亡災害など）を複数の事業場で発生させた事業者に対し、厚生労働大臣が事業者の全ての事業場における安全又は衛生に関する改善計画を作成・提出すべきことを指示するものであり、所要の指示や勧告に従わない事業者には企業名公表などのペナルティが課される（安衛法第78条）（労働調査会2015：905-907）（労務行政研究所2017：749-759）。

(5) 労働安全コンサルタント及び労働衛生コンサルタントは、他人の求めに応じ報酬を得て、労働者の安全・衛生の水準の向上を図るため、事業場の安全・衛生に関する診断とこれに基づく指導を行うことを業とするものである（安衛法第81条）<sup>(11)</sup>。制度の趣旨・目的は、企業外部の専門家による安全衛生の診断、安全衛生改善計画の作成・変更に関する助言などを通じて、事業場の労働安全衛生水準の向上を図ることにある（安衛法第80条）（労働調査会2015：911-924）（労務行政研究所2017：762-781）。

### 3. 職場の安全衛生管理に関する規制の実効性確保の実態

〔労働基準監督制度と監督指導等の状況〕

職場の安全衛生管理に関する規制は、事業者を始めとする義務主体が法定の労働安全衛生に関する最低基準を自主的に遵守することを前提としているが、法令違反を未然に防ぎ、違反があった場合には速やかな是正を図るため、安衛法に罰則規定（安衛法第115条の2～第123条）を設け、労働基準監督制度に基づく監督指導等を実施することにより規制の実効性を確保しようとしている。そのため労働基準監督官には、事業場への立ち入り調査、関係者に対する質問、帳簿・書類などの検査、作業環境の測定、製品・原材料・器具の取去を行う権限が付与され、安衛法の規定に違反する罪に関しては、刑事訴訟法の規定に基づく特別司法警察職員の職務を担うこととされている（安衛法第91条～第92条）。

先にみたように、労働基準監督制度を運用する組織体制は、都道府県労働局（47）、労働基準監督署（325）、労働基準監督官（2,923名）により構成される<sup>(12)</sup>。監督指導を含む労働行政の運営は、厚生労働省が毎年度策定する「地方労働行政運営方針」に基づき、都道府県労働局が管内の事情を反映した方針を策定し計画的に行われる（厚生労働省2019a）<sup>(13)</sup>。例えば神奈川県

労働局の場合、管内の社会経済情勢、雇用情勢、働き方改革や労働条件に関する現状と課題を踏まえ、労働安全衛生分野に関しては、長時間労働の是正・過重労働による健康障害防止に係る監督指導等の徹底、過労死防止対策の推進を重点施策として掲げている。特に第13次労働災害防止計画の推進に関連して、建設業における墜落・転落災害などの防止、製造業における施設・設備・機械等に起因する災害の防止、職場におけるメンタルヘルス対策の推進、就業構造の変化及び働き方の多様化に対応した取組み（第3次産業、非正規雇用労働者、外国人労働者、高齢労働者などを対象とした労働災害防止対策）、化学物質による労働災害防止対策の推進などを重点項目としている（神奈川労働局2019）。

また、最近の監督指導等の状況をみると、監督指導の対象となる事業所数は約428万事業所、労働者数は5,209万人であるのに対し、年間の監督実施件数は169,623件（内訳は定期監督・災害監督等が134,617件、申告監督が21,944件、再監督（定期監督・申告監督の際に法違反を指摘された事業場に対する是正の有無を確認するための監督）が13,012件）となっている（厚生労働省2018c：21）。詳細をみると、定期監督を実施した事業場のうち、法違反が認められたものは89,972件（違反率は66.8%）、法違反の内容は、労働時間（31.5%）、安全基準（26.3%）、健康診断（21.9%）、割増賃金（20.9%）、労働条件の明示（15.3%）、賃金台帳（11.3%）の順である。また、労働者を就業させる事業の建設物、寄宿舍・設備、原材料などが安全・衛生に関する基準に違反すると認められる場合、労働災害を未然に防止するために労働基準監督署長等が行う使用停止等命令処分等件数は5,286件（内訳は、使用停止等処分5,284件、緊急措置命令2件。業種別では建設業3,263件、製造業が1,707件で全体の94.1%）となっている。その他、司法処分の件数（労働基準監督官が検察庁に送検した件数）は890件（内訳は労基法違反380件（42.7%）、安衛法違反497件（55.8%）、最低賃金法違反13件（1.5%））とされている（厚生労働省2018c：22）<sup>(14)</sup>。

〔労働災害防止団体の取組み〕

労働災害の低減に向けた取組みでは、国（行政）が行う監督指導だけでなく、事業主による自主的な災害防止活動も必要不可欠である。そのため「労働災害防止団体法」（以下、「災防法」という。）に基づき、労働災害の防止を目的とする事業主の団体による自主的な活動を促進するために、民間法人である「中央労働災害防止協会」が設立（1964年）されている<sup>(15)</sup>。

中央労働災害防止協会は、①労働災害防止協会（1号会員：建設業労働災害防止協会、陸上貨物運送事業災害防止協会、港湾貨物運送事業災害防止協会、林業・木材製造業労働災害防止協会）、②全国的規模の事業主団体（2号会員：日本ガス協会、日本機械工業連合会、日本鉄鋼連盟、日本自動車工業会、日本民営鉄道協会など64団体）、③都道府県労働基準協会連合会等及びこれに順ずる地方別の経営者団体（3号会員：都道府県ごとに設立された労働基準協会、労働基準連合会など48団体）、④その他の労働災害防止団体（4号会員：全国労働衛生団体連合会、日本産業衛生学会、日本クレーン協会、日本ボイラ協会など19団体）を正会員として、

労働災害の防止に関し会員間の連絡・調整を行う組織である(災防法第11条第1項)<sup>(16)</sup>。

中央労働災害防止協会では、①全国安全週間(毎年7月に実施)や全国労働衛生週間(毎年10月に実施)、年末年始無災害運動など職場における安全衛生意識高揚を図る運動の展開、②企業の安全衛生スタッフの養成事業、③安全・衛生管理士など専門家による診断・技術支援、リスクアセスメントに関する人材の養成、作業環境測定などの技術サービスの提供、④海外の動向を含む最新の安全衛生情報の提供、⑤労働災害防止に関わる各種の調査研究、⑥災害ゼロを目指すゼロ災運動の展開、⑦快適な職場づくりに向けた研修会・セミナーの開催、講師派遣などの事業を行っている(災防法第11条第1項・第2項)<sup>(17)</sup>。

また、中央労働災害防止協会の正会員のうち、都道府県単位で設立された労働基準協会など(3号会員)は、都道府県労働局・労働基準監督署や関連する団体と密接な連携を保ちながら、企業の労働災害防止活動を支援している。例えば神奈川県の場合、県内に所在する企業を会員とする神奈川労務安全衛生協会(公益社団法人)が、労働局の登録教習機関としてプレス機械等の作業主任者技能講習や第一種衛生管理者などの免許取得養成講習などを実施している<sup>(18)</sup>。また、県内12か所にある労働基準監督署ごとに対応する形で設置された支部では、労働局の行政運営方針や法令などの周知活動、安全週間・衛生週間の推進大会、新入社員安全衛生教育、職長教育、リスクアセスメント講習など、管内の事業所を対象としたきめ細かな労働災害防止活動を展開している<sup>(19)</sup>。

この他、その他の労働災害防止団体(4号会員)では、機械の安全性を確保するための検査・検定、免許を取得するための技能講習などを行う団体もある。例えば日本クレーン協会では、クレーンに関する調査研究・企画の整備、厚生労働大臣の登録を受けたクレーン、ゴンドラ、エレベーターなどの性能検査・型式検定、クレーンなどの運転士免許取得のための実技講習、各種図書出版など知識の普及活動などを行っている<sup>(20)</sup>。また、日本ボイラ協会では、厚生労働大臣の登録を受け、登録性能検査機関としてボイラー・第一種圧力容器を対象とする性能検査(安衛法第41条第2項)を行うほか、登録個別検定機関として第二種圧力容器、小型ボイラー・小型圧力容器を対象とする個別検定(安衛法第44条)などを実施している<sup>(21)</sup>。

## おわりに

[職場の安全衛生管理に関する規制の実効性確保の特徴]

安衛法に基づく職場の安全衛生管理に関する規制の目的は、労働災害の防止と労働者の安全と健康の確保にある。この目的を達成するため、安衛法では①物的規制(製造・流通段階と使用段階における機械・器具その他の設備、原材料、建設物、作業環境の安全・衛生の確保)、②作業規制(作業自体の安全の確保)、③人的規制(安全衛生教育、免許・技能講習などの就業制限による作業従事者の能力を担保)を実施している。



また、このような規制の実効性を確保するため、①労働災害防止計画の制度、②労働者に対する知識の付与（情報提供）、労働者の参加の保障と促進、③労働基準監督制度（罰則・送検処分を含む）、④一般の安全衛生改善計画・特別安全衛生改善計画、⑤労働安全コンサルタント及び労働衛生コンサルタントなどの手段が用いられるほか、中央労働災害防止協会などの労働災害防止団体による災害防止活動が、国（行政）が行う監督指導と相まって事業主による自主的な災害防止活動を促進する体制が構築されている。

規制の実効性を確保するための法的仕組みからみれば、職場の安全衛生管理においてリスクとなる要素（危険な作業を必要とする機械や業務など）に対し、特定行為の禁止、資格制度、検査検定制度、基準・認証制度などの手段が適宜に組み合わせられたものとなっている。また、規制の執行活動では、事業者等の義務主体が法定の労働安全衛生に関する最低基準を自主的に守ることを前提としつつ、重点施策・項目の提示（労働災害防止計画、地方労働行政運営方針の策定など）、行政的監督手法による法令違反是正の取組み（労働基準監督制度）、行政外部のネットワークの構築と連携（労働災害防止団体との協力）などを通じて、規制目的の実効性の確保に努めている。総じて言えば、規制対象の規模（事業者・労働者など）や多様性（機械・器具、設備、原材料、作業環境など）に対し、行政が用いることのできる資源（組織・権限・人員・予算）には限界があることを前提とした柔軟な取組みがなされているものといえよう。  
〔労働災害の現状と課題〕

こうした職場の安全衛生管理に関する規制とその実効性の確保をめぐる取組みは、これまでにどのような効果を上げているのか。この点、戦後の日本における労働災害の動向（図2参照）をみると、死傷者数は1961年に481,686人とピークを記録した後、1967年以降は30万人台、1980年代は20万人台、1990年代以降は10万人台に減少している（倉橋1997：309-323）（労務行政研究所2017：25-30）（中央労働災害防止協会2019：2）。また、死亡災害をみると、1960年代に6,000人前後を推移した後、1970年代には5,000人台から3,000人台に低下し、1980～90年代は2,000人台、2000年代は1,000人台を推移した後、最近では1,000人を下回るようになり長期的にみれば減少傾向を示している（倉橋1997：309-323）（労務行政研究所2017：25-30）（中央労働災害防止協会2019：2）。このように労働災害が減少した理由には、産業構造の変化、技術革新、企業・業界団体の自主的な労働災害防止対策の推進などの要因が考えられるが、1972年の安衛法制定以降3年間で死亡災害が約2,000人減少するなどの著しい変化もみられ、安衛法を中核とする法令に基づいた職場の安全衛生管理に関する規制が一定の効果を発揮していることが窺われる。

その一方で、2018年の労働災害発生状況を見ると、死亡者数は909人で過去最少となったものの、休業4日以上死傷者数は127,329人となり3年連続で増加した（厚生労働省2019）。労働災害による死傷者数が減少しなくなった要因には、第3次産業における労働者数の急速な増加、労働力の高齢化などが挙げられ、これまでとは異なる切り口、視点に基づく対策が必要



図2 労働災害発生状況の推移

(出典) 厚生労働省 (2019b) 「平成30年労働災害発生状況」。

とされている (厚生労働省 2018a)。また、過労死などの過重労働による労働災害 (業務における過重な負荷による脳血管疾患若しくは心臓疾患を原因とする死亡若しくはこれらの脳血管疾患若しくは心臓疾患若しくは精神障害を指す) も、近年における労災認定件数が700件で推移するなど依然として深刻な社会問題となっている (表1参照) (厚生労働省 2018a)。

表1 脳・心臓疾患及び精神障害に係る労災認定件数の推移

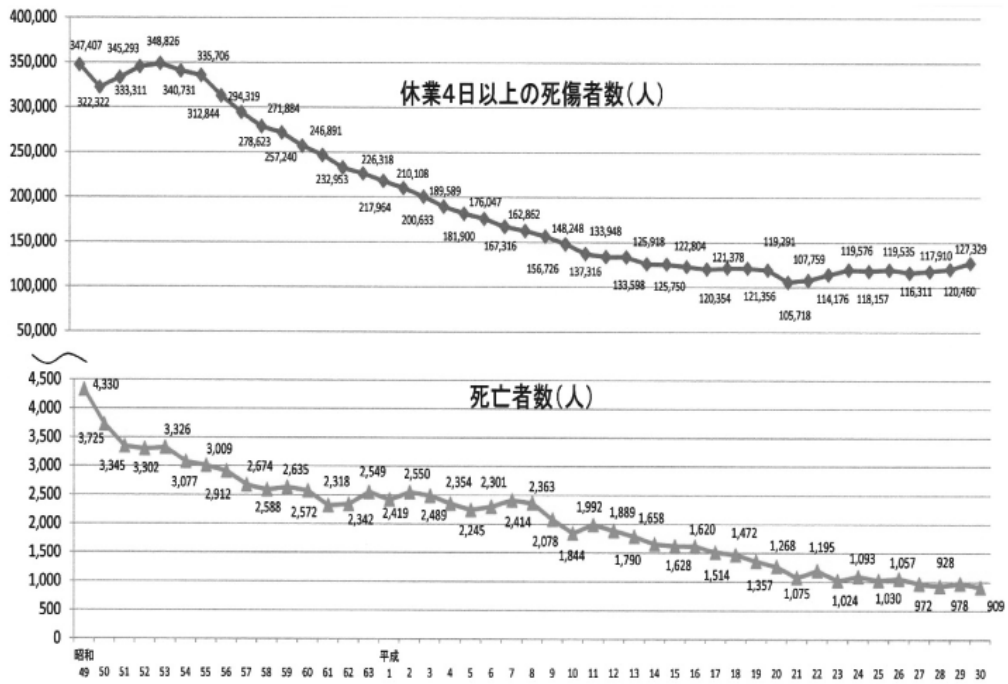
		平成24年度	平成25年度	平成26年度	平成27年度	平成28年度
脳・心臓疾患	労災認定件数	338	306	277	251	260
	うち死亡件数	123	133	121	96	107
精神障害	労災認定件数	475	436	497	472	498
	うち自殺件数	93	63	99	93	84
労災認定件数合計		813	742	774	723	758
うち死亡・自殺合計		216	196	220	189	191

※ 自殺は未遂を含む。

(出典) 厚生労働省 (2018a) 「第13次労働災害防止計画 (本文)」 (8頁の表8)。

既にみたように規制の実効性を確保するための行政活動 (執行活動) には、法的制約、予算・資源の制約、社会状況の複雑さと流動性、規制対象者の利己的行動などの制約のもと、適法性、

有効性、効率性の要件を満たすことが求められる（森田 2017：175-176）。この点、職場の安全衛生管理に関する規制は、規制対象となる事業場（と労働者）の規模と比べて、用いることのできる行政資源（とりわけ労働基準監督制度の組織・人員）に限界があり、また、社会経済情勢の変化（少子高齢化の進展、経済構造の変化、ライフスタイルの変化、働き方改革など）や技術革新（新規の設備・機械・化学物質等の導入）などの影響を受けやすい分野といえる。そのため、規制の目的（労働災害の防止・労働者の安全と健康の確保）の達成に向け、常に行政課題の把握に努め、最適な規制手段と規制の実効性の確保を模索するための取組みが今後も求められている。

〔注〕

- (1) 例えば、本稿においても参照した先行研究として、経済学の分野では、社会的規制研究会（編）（1996）『これからの社会的規制』通商産業調査会、植草益（編）（1997）『社会的規制の経済学』NTT 出版、植草益（2000）『公的規制の経済学』NTT 出版、八代尚宏（編）（2000）『社会的規制の経済分析』日本経済新聞社、山本哲三・野村宗訓（編著）（2013）『規制改革 30 講 - 厚生経済学的アプローチ』中央経済社などがある。法学の分野においても多数の先行研究が存在するが、社会的規制の分野に関する近年の著作として、野口貴公美・幸田雅治（共編著）（2009）『安全・安心の行政法学「いざ」というとき「何が」できるか?』、平田彩子（2009）『行政法の実施過程 - 環境規制の動態と理論 -』木鐸社、行政上の義務履行を確保するための法的仕組みのあり方を検討した研究として、西津政信・田村泰俊（2003）『わが国の行政規制の実効性確保のための新たな制度に関する研究』国土交通省国土交通政策研究所、曾和俊文（2011）『行政法執行システムの法理論』有斐閣などがある。また、行政学の分野における代表的な研究として、自動車運送事業に対する規制行政の実施過程を検討した森田朗（1988）『許認可行政と官僚制』岩波書店、木造建築・軽自動車・電気用品の安全基準の設定をめぐる規制行政機関の行動と実態を分析した村上裕一（2016）『技術基準と官僚制 変容する規制空間の中で』岩波書店、日本と EU の化学物質を対象とした規制政策の比較検討を行った早川有紀（2018）『環境リスク規制の比較政治学 - 日本と EU における化学物質政策 -』ミネルヴァ書房、行政機関間の連携の実態を検討した伊藤正次（編）（2019）『他機関連携の行政学 事例研究によるアプローチ』有斐閣などが挙げられる。
- (2) 例えば、土地利用規制に関する事例研究として、伊藤弘基、佐藤遼、瀬田史彦、城所哲夫（2014）『特別用途地区による大規模集客施設の立地規制における自治体間の調整実態に関する研究』日本都市計画学会『都市計画論文集』（49 巻 3 号：657-662）、磯崎初仁（2015）『神奈川県における土地利用調整システムの成立と展開 - 「開発抑制方針」はなぜ実効性を持ち得たか - 』中央大学法学部『法学新報』（121 巻 9・10 号：1-58）、建築規制に関する研究として、金振、馬場健司、田頭直人（2010）『地方自治体における建築物環境配慮計画書制度の実効性の評価：行政法学的視点に基づく条例および制度運用実態分析を中心に』日本都市計画学会『都市計画論文集』（45 巻 3 号：715-720）などがある。
- (3) ただし、経済的規制と社会的規制の両方の要素を持つ規制（営業免許など）があることには注意を要する（社会的規制研究会 1996：24-26）。
- (4) この他、消費者や労働者の安全・健康の確保、環境の保全、災害の防止等を目的とした規制を社会的規制とみなす、より限定的な捉え方もある（社会的規制研究会 1996：23-24）。
- (5) 規制行政以外の行政活動の類型として、給付行政（私人に対する財、役務、情報などの給付が行政資源取得の対価ではなく、給付それ自体を目的として行われる場合。サービス行政ともいう。）、行

政資源取得行政(国・自治体が自らの事務を処理するために必要な資金、土地などの取得を目的とする場合。調達行政ともいう。)がある(宇賀 2017: 84)。

- (6) 職場の安全衛生管理に関係する法令としては、安衛法とその関係政省令以外に、労働基準法、じん肺法、労働災害防止団体法、作業環境測定法、船員法、鉱山保安法、国家公務員法、地方公務員法、家内労働法などが挙げられる。
- (7) 安衛法第2条第1号では、労働災害を「労働者の就業に係る建設物、設備、原材料、ガス、蒸気、粉じん等により、又は作業行動その他業務に起因して、労働者が負傷し、疾病にかかり、又は死亡することをいう。」と定義する。
- (8) 請負に係る規制では元方事業者、リース業を対象とする規制では機械・建築物等の貸与者が義務主体となる。また、安衛法第4条では、「労働者は、労働災害を防止するため必要な事項を守るほか、事業者その他の関係者が実施する労働災害の防止に関する措置に協力するよう努めなければならない。」として、労働者の遵守義務を定めている(畠中 2019: 60-67)。
- (9) 第13次労働災害防止計画の概要に関し、厚生労働省(2018b)「第13次労働災害防止計画(計画の本文)」, 厚生労働省(2018a)「第13次労働災害防止計画(計画の概要)」を参照。
- (10) 労働基準監督制度は、ILO(国際労働機関)第81号条約「工業及び商業における労働監督に関する条約」(1947年採択)に規定されているように労働保護法制に必要不可欠な監督機関と位置付けられている。日本の労働基準監督制度は工場法(1911年制定)時代にそのルーツ(1915年以降の工場監督官・工場監督官補の制度)があり、労働基準法の制定(1947年)に伴い、国の直轄機関として法令の周知、違反の指摘、是正指導から送検処分までを担う自己完結性の強い組織として整備されるに至った(畠中 2019: 95-97)。
- (11) コンサルタントになるためには、厚生労働大臣が行う労働安全コンサルタント又は労働衛生コンサルタント試験に合格し、それぞれ所定の名簿に一定の事項の登録を行わなければならない(安衛法第82条~第84条)。
- (12) 労働基準監督官の数は、(厚生労働省 2018c: 31)に基づく2016年度の定員である。
- (13) 厚生労働省が策定した2019年度の地方行政運営方針における重点施策は、①働き方改革による労働環境の整備、生産性向の推進等、②人材確保支援や多様な人材の活躍促進、人材投資の強化、③労働保険の適用・徴収業務の適切な取組み、④毎月勤労統計調査に係る雇用保険、労災保険給付等の追加給付、⑤東日本大震災からの復興支援とされている。
- (14) 以上、最近の監督指導等の取組み状況に関するデータは、(厚生労働省 2018c)を参照した。
- (15) 中央労働災害防止協会の設立経緯に関し、(中央労働災害防止協会 2011)を参照。
- (16) 中央労働災害防止協会の会員組織に関し、同協会ホームページ(<https://www.jisha.or.jp/about/kaiin/index.html>)を参照(2019年11月1日閲覧)。
- (17) 中央労働災害防止協会が展開する事業に関し、同協会ホームページ(<https://www.jisha.or.jp/about/service.html>)を参照(2019年11月1日閲覧)。
- (18) 神奈川労務安全衛生協会の概要・活動に関し、同協会ホームページ(<http://www.roaneikyo.or.jp/index.html>)を参照(2019年11月1日閲覧)。
- (19) 神奈川労務安全衛生協会横浜南支部ホームページ(<http://www.roaneikyo.or.jp/shibu/yokominami/index.html>)及び同支部の機関紙「よこはまみなみ」(No.208:平成31年4月号)を参照(2019年11月1日閲覧)。
- (20) 日本クレーン協会の概要・活動に関し、同協会ホームページ(<http://www.cranenet.or.jp/>)を参照(2019年11月1日閲覧)。
- (21) 日本ボイラ協会の概要・活動に関し、同協会ホームページ(<http://www.jbanet.or.jp/>)を参照(2019年11月1日閲覧)。



〔参考文献〕

- 井出秀樹（1997）「社会的規制の手段」植草益（編）『社会的規制の経済学』NTT出版
- 植草益（1997）「社会的規制研究の必要性」植草益（編）『社会的規制の経済学』NTT出版
- 植草益（2000）『公的規制の経済学』NTT出版
- 宇賀克也（2017）『行政法概説Ⅰ行政法総論【第6版】』有斐閣
- 神奈川県労働局（2019）「平成31年度神奈川県労働局行政運営方針」
- 倉橋義定（1997）「労働災害防止法制の変遷と労働安全衛生法の制定」労働省労働基準局（編）『労働基準行政五〇年の回顧』日本労務研究会
- 経済改革研究会（1993）「規制緩和について（中間報告）」
- 厚生労働省（2018a）「第13次労働災害防止計画（計画の本文）」
- 厚生労働省（2018b）「第13次労働災害防止計画（計画の概要）」
- 厚生労働省（2018c）「平成28年労働基準監督年報（第69回）」
- 厚生労働省（2019a）「平成31年度地方労働行政運営方針」
- 厚生労働省（2019b）「平成30年労働災害発生状況」
- 社会的規制研究会（編）（1996）『これからの社会的規制』通商産業調査会
- 高橋滋（2018）『行政法 第2版』弘文堂
- 中央労働災害防止協会（編）（2011）『安全衛生運動史 安全専一から100年』中央労働災害防止協会
- 中央労働災害防止協会（編）（2019）『安全の指標（令和元年版）』中央労働災害防止協会
- 中原茂樹（2018）『基本行政法 第3版』日本評論社
- 西尾勝（2000）『行政の活動』有斐閣
- 畠中信夫（2019）『労働安全衛生法のはなし』中央労働災害防止協会
- 藤田宇靖（2013）『行政法総論』青林書院
- 森田朗（2017）『新版 現代の行政』第一法規
- 八代尚宏・伊藤隆一（2000）「安全規制の改革-検査・検定・公的資格の横断的見直しを」八代尚宏（編）『社会的規制の経済分析』日本経済新聞社
- 臨時行政改革審議会事務局（編）（1989）『規制緩和の推進』ぎょうせい
- 労働調査会（編）（2015）『労働安全衛生法の詳解-労働安全衛生法の逐条解説-改訂4版』労働調査会
- 労務行政研究所（編）（2017）『労働安全衛生法（労働法コンメンタール<sup>⑩</sup>）』労務行政

〔付記〕

本論文は、筆者が研究協力者として参画する労働安全衛生総合研究事業（厚生労働科学研究費補助金）「労働安全衛生法の改正に向けた法学的視点からの調査研究（19JA1001）」（期間：2019年4月～2020年3月）の一環として執筆されたものである。

（おおやぶ としゆき 公共政策学科）

2019年11月15日受理

特別寄稿

## 副業・兼業者、フリーランスに対する 安全衛生法政策に関する試論

近畿大学法学部教授 厚生労働省労働政策審議会安全衛生分科会公益代表委員  
日本産業保健法学会設立発起人

三柴 丈典 (みしば たけのり)



### Profile

1971年生まれ。1999年に一橋大学大学院法学研究科博士後期課程修了、博士(法学)。2000年に近畿大学法学部に奉職し、2012年より同教授。専門は、労働法、産業保健法。2011年4月より厚生労働省労働政策審議会安全衛生分科会公益代表委員。2014年7月衆議院厚生労働委員会参考人。産業保健・安全衛生法に関する著書や論文を多数執筆している。2020年8月にUKのRoutledge (Taylor & Francis Group) で研究書を発刊。2020年11月に日本産業保健法学会を設立予定。

「働き方改革」が進む中、副業・兼業、フリーランス等の促進が図られています。この状況を踏まえ、現在、厚生労働省労働政策審議会安全衛生分科会において、副業・兼業者、フリーランス等に関する労働安全衛生法政策のあり方について、審議が進められています。

副業・兼業をする労働者、フリーランスに対する安全衛生制度には、本業のみに就業する労働者とは異なり、不十分な点が少

## 本定例会のポイント

### Point 副業・兼業、フリーランスの業務内在リスク

労働安全衛生政策では、基本的に、事業場の業務内に内在する心身のリスクへの対応が求められるので、副業・兼業、フリーランスでの就業に内在するリスクの特定と対応が求められる。副業・兼業の場合、本業先では把握されている本人の健康状態が副業・兼業先に把握されていないこと等、本業先との連携がなされないことに伴う健康障害リスク、一方は冷房がきつく、他方は熱射が強い、本業先と副業・兼業先の運営方針の違い等の労働条件の格差への適応の困難などが想定され、フリーランスでは、生活苦、長時間労働内外の要因による疲労・ストレス、業務上ばく露する危険な化学物質、機械、電気等に関わるリスクが想定される。

### Point 業務内在リスクの調査と対応上の原則

副業・兼業・フリーランスの健康リスクへの対応では、使用者や委託者・業務管理者の指示による場合を除き、自己決定自己責任が原則となる。しかし、労働安全衛生法政策の原理や近年の動向に照らせば、使用者らが業務内在リスクを生み出していたり、関連情報を持ち、管理できる場合、管理の責任を持つべきである。また、生活苦を含め、心理社会的なリスクにも、一定の配慮を行う必要がある。もともと、本人が申告しないと認識し難いリスクについては、使用者らが自己申告の機会を提供することが求められ、それをもって足りると解される。

### Point 産業界の活用

副業・兼業・フリーランスの健康リスクへの対応では、産業界が重要な役割を担う。ただし、本人が副業・兼業等を事業者知られたいくない場合には、産業界のみが知り、事業者には必要な就業上の配慮のみが伝えられるような仕組みが求められよう。



## 1. はじめに

現在、「働き方改革実行計画」(平成29年3月28日働き方改革実現会議決定)に基つき、多様な働き方促進策の一環として、厚生労働省を担当省とし、副業・兼業、フリーランス等の促進が図られている(以下、「新たな促進策」という)。主体的なキャリア形成、所得増加、転職準備から地方創生まで、様々なメリットが想定されており、希望者は増えているよう<sup>1)</sup>。しかし、行政が示したデータによれば、いわゆる正社員に実際に副業・兼業を認めている企業等は少なく、就業する労働者側も、実際には、1カ所での勤務では十分な生計費を賄えない等の理由もあって、所得増加を目的とすることが多い。他方、副業・兼業を行ったこと自体を理由に、強い悩み、不安、ストレスが増大する傾向もさほど見られ<sup>2)</sup>ない。たしかに、所得が低かったり、雇用不安があったり、勤務時間が著しく長くなれば、増大しているが、それは、副業・兼業に特有の傾向とは言えないだろう<sup>3)</sup>。

こうした前提を踏まえ、現在、厚生労働省では、労働政策審議会安全衛生分科会において、副業・兼業者、フリーランス等に関する労働安全衛生法政策のあり方について、審議が進められ、筆者も公益代表委員として参画している。本稿では、労働安全衛生法を専門的に研究してきた者として、この課題に関する私見を

綴る。

## 2. 踏まえるべき原則

1) 新たな促進策に伴う業務内在リスクを想定して、管理方法を考案すること  
労働安全衛生は、業務に内在する心身のリスク管理を基本的な使命としている。リスク要因が職域外に存在する場合、予防効果を挙げため、できる限り対策の触手を延ばす必要がある。また、生じるリスクや社会のリスク認識の変化に伴い、求められる対策も変化する。すなわち、元々はブルーカーラー労働者を中心とした対象とした技術的対策が中心だったところ、生活習慣病対策、疲労・ストレス対策、ハララスメント対策などの健康対策、すなわち労働時間の長さや構成、業務の質をはじめとするさまざまな労働条件に関わる社会的対策を多分に取り込むようになっている。健康問題は、生き方、働き方に関わる哲学の課題でもあるため、全てをリスクと捉えることは適当でないが、少子高齢化の背景もあり、悪質なものは対策の対象とすべき段階に至っている。

そこで、新たな促進策に伴う業務内在リスクを考えれば、さしあたり、生活苦、長時間労働、長時間労働以外の疲労・ストレス要因による健康障害などが考えられるが、フリーランスの場合、労働者でなくなること等で、従来の労働安全衛生法による保護が及ばなくなる可能

性があるため、建設業における一人親方保護のための施策<sup>3)</sup>を、備置契約者など、さまざまな雇用類似の就業者に及ぼすこととの是非と、及ぼす場合の範囲を、中長期的検討課題とすべきだろう。私見では、安全衛生では、リスクを創出する者や、情報を得て、支配管理できる者が管理責任を負うことが原則と解されること(筆者は、リスク創出者管理責任負担原則<sup>4)</sup>と呼んでいる)、フリーランス等が、仮に組織的従属性(組織の中に組み込まれ、その秩序遵守を求められることによる不自由)から離れるとしても、経済的従属性(生計を依存していることによる上下関係)から離れない場合も多いことからすれば、たとえ労働基準法や労災保険法が適用されない者でも、その観点で広く適用対象を設定すべきと解する。

SOHO的なフリーランスの家内就業については、従来、家内労働法(昭和45年法律第60号)の規制があった。その立法趣旨には、経済的な従属性を含め、準労働関係の実態にありながら、生活的不安定、低劣な就業条件などの問題があるとの認識があったため<sup>5)</sup>、委託内容、委託期日、工賃、支払期日等の手帳による管理を通じて、彼/彼女らの就業条件を幅広く向上させようとした。こうした背景と対策は、現代のSOHO的に就業するフ

リーランスにも妥当するだろう。殊に、幅広い就業条件の向上促進策は、昨今の安全衛生法政策が重視する心身の健康対策に貢献するだろう。しかし、家内労働法が、主に物の加工を行う内職者を想定し、安全衛生面では、主に業務の委託者が内職者に提供する機械器具や原材料等の安全を確保しようとしていたこと等は、データの加工やシフト構築等を行うことの多い現代のSOHO的業者には、あまり妥当しないだろう。

なお、新たな促進策に伴う業務内在リスクについては、厚生労働科学研究等による調査が求められよう。

2) 雇用類似者(フリーランス等)については、連帯による交渉力の向上も検討すること  
周知の通り、労働法は、労働者に団結権等を認め、正当な組合の行動に民事責任や刑事責任を与え、さらに労働委員会制度などの行政救済制度を設けるなど、積極的に支援することで使用者とのパワーバランスの均衡を図ろうとしてきた。

雇用類似者にも、それに応じた連帯支援の制度を検討すべきだろう。少なくとも、雇用類似者による集団的な交渉や集団訴訟を阻害する契約の制限、雇用類似者から発注者に対する他に業務を受託している雇用類似者への連絡要求への対応

3) 建設工事従事者の安全及び健康の確保の推進に関する法律(平成28年法律第111号)の制定、建設工事従事者の安全及び健康の確保に関する基本的な計画の策定(平成29年6月)など。

4) この原則は、UKの労働安全衛生法に明記されている。詳細は、渡川亮、三架七典「リスクアセスメントを核とした諸外国の労働安全衛生法制度の背景・特徴・効果とわが国への対応可能性に関する調査研究の紹介」労働安全衛生研究(2020年) [https://www.jstage.jst.go.jp/article/osh/advpub/0/advpub\\_IOSH\\_2020-0006-KE\\_article-char/ja/](https://www.jstage.jst.go.jp/article/osh/advpub/0/advpub_IOSH_2020-0006-KE_article-char/ja/)、最終閲覧日:2020年9月17日)及び、三架七典「分相研究報告書・イギリスのリスクアセスメントと法」厚生労働科学研究費補助金(労働安全衛生総合研究事業)「リスクアセスメントを核とした諸外国の労働安全衛生法制度の背景・特徴・効果とわが国への対応可能性に関する調査研究(第1分冊)」(2017年)127-357頁を参照されたい。

5) 労働事務次官通達「家内労働法の施行について」(昭和45年10月1日発基第115号)。

業務などの支援策の創設は必要ないように思われる。手始めに、トータルで一定規模以上の発注や業務管理を行っている業者に対し、雇用類似者の健康管理や委託条件の適正化に関する監査委員会を設置させると共に、行政において、そうした問題に関する苦情処理兼相談センターを設置し、ADR機能を持たせることも考えられる。

### 3) 就業者の自助努力(職業能力の研鑽と自分の個性に合った適応の努力等)が必要なこと

たとえ、さまざまな外的要因があっても、そもそも、雇用類似の就業形態や、本業先の許可を得ない副業・兼業は、就業者自身の選択だし、何より、心身の健康を高めるには、本人が主体的なキャリア形成に努める必要がある。すなわち、職業能力の研鑽と自分の個性に合った環境適応の努力を重ねる必要がある。

## 3. 安衛法体系における位置づけ

新たな促進策を、安衛法体系上どう位置づけるべきか。法改正すべきか、政令(法施行令)・省令(規則)を改正すべきか、ガイドラインの策定や改定に留めるべきか。

そもそも、新たな促進策は、個別的には契約の自由、集团的には労使自治に帰

する問題であり、労働政策審議会安全衛生分科会において、労働側委員から、そもそも国が積極的に推進すべき事柄かを疑問視する旨述べられていた<sup>6)</sup>ことから、基本的には、ガイドラインでの推進を基本とすべきであろう。ただし、労働側委員は、生計維持のために副業・兼業等を行う労働者が多い実態も踏まえ、新たな促進策に伴う健康確保等の労働者保護の法定には積極的である。他方、使用者側委員は、健康確保等もガイドラインでの推進にとどめるべきと述べている<sup>7)</sup>。

上述した通り、筆者は、疲労・ストレス、生活習慣等にかかる健康問題は、十分に自己決定的な課題だと考えており、各選択の利害得失に関する情報、試行錯誤と再選択の機会を広く提供されれば、極論だが、自ら不調を招くこと、寿命を縮めることもやむを得ない面があると考えられている。新たな促進策では、なおさらと見える(ただし、機械、建設工事、化学物質など、施設等の生産手段や原材料にかかる情報や支配管理権限を発注者、業務管理権者らが持つことが多い危険源への対策では、事情が異なる)<sup>8)</sup>。よって、それに伴う健康管理等についても、基本的には、ガイドラインでの誘導を基本としつつも、副業・兼業等については、労働者による自己申告監査の提供の使用urerへの義務づけ、フリーランス等の雇用類似者については、上述した連帯支援策、内部監査制度、行政による救済制度、発

6) 第124回労働政策審議会安全衛生分科会(令和元年10月4日)における漆原委員の発言。

7) 第132回労働政策審議会安全衛生分科会(令和2年8月19日)における鈴木委員の発言。

8) 筆者は、第130回労働政策審議会安全衛生分科会(令和2年6月10日)で、兼業・副業に伴う健康問題については、ただ長時間労働を招くからいけないというのではなく、「質的な面も考えなくてはならない」。最終的には、組織と個人の自己決定という考え方も尊重していかないとはいけません<sup>9)</sup>と述べた([https://www.mhlw.go.jp/stf/newpage\\_12452.html](https://www.mhlw.go.jp/stf/newpage_12452.html))。

注者や業務管理者による業務上の健康リスクの調査と対応策(リスクアセスメントに基づくリスク管理)等は、法定する必要があるのではないかと考える。

## 4. 法第1条との関係

安衛法第1条は、同法の目的の主な達成方法として、①危害防止基準の確立、②責任体制の明確化<sup>9)</sup>、③自主的活動の促進策、を掲げている。では、これらを副業・兼業者、フリーランス等の雇用類似者にどう展開するか。

(副業・兼業者について)

既存の危害防止基準の遵守は、基本的には、個々の事業場の事業者の責任で行うべきだろう。もともと、その副業・兼業に特有のリスク(たとえば、移動の負担<sup>10)</sup>、その他、本業先の労働時間、職責などの業務上の負荷が副業・兼業先把握されている本人の健康状態が副業・兼業先との把握されていないこと等、本業先との連携がなされないことに伴う健康障害リスク、一方は冷房がきつく、他方は熱射が強い、本業先と副業・兼業先の運営方針の違い等の労働条件の格差への適応の困難など)については、先ず、本業先の

(雇用類似者について)

フリーランス等の雇用類似者については、上述したように、そもそも生じ得るリスクが通常の労使関係下におけるものとは異なることが多く、健康リスクであれば、本人の引き受けが原則となる。しかし、発注者がリスクを創出しているか、その情報と支配管理権限を持ってい

指示に基づく副業・兼業の場合、本業先の事業主に、労働者派遣法が定める派遣元責任者のように、本業先と副業・兼業先の連携を促す担当者を選任し、そうしたリスクの調査と対応を行わせる必要がある。

本業先の指示に基づかない場合、労働者に副業・兼業実態、使用者が認識しにくい就業上のリスクについて自己申告を行う機会の提供までは法令で使用者に求め、それでも捕捉しづらい副業・兼業実態や就業上のリスクについては、新設された安衛法第14条の4第2項等を根拠に産業医等による面談を行わせ、捕捉を図るしかないように思われる。産業医等が面談で知り得た副業・兼業実態について、本人が望む場合には産業医等のみが把握し、事業者には原則として求められ就業上の配慮のみを伝達させる方途も考えられる。

9) 現行安衛法が労働防止効果を挙げた理由の中でも、責任体制の明確化が特に重要な役割を果たしたと解されることにつき、厚生労働科学研究費補助金(労働安全衛生総合研究事業)「労働安全衛生法の改正に向けた法学的視点からの調査研究報告書(令和元年版)」(研究代表者:三塚文典)に記載された社会調査結果のうち、467頁(「発注効果をもたらしたと解される現行安衛法の要案」、467頁(安全衛生を重視している大規模企業等の経営者が講じている対策)、468頁(安全衛生を重視している中小規模企業等の経営者が講じている対策))を参照されたい。

10) なお、厚生労働省「副業・兼業の促進に関するガイドライン」にも示されているように、保険関係の処理において、事業場間の移動は、当該移動の終点たる事業場において労働者の提供を行うために行われる通勤と考えられ、当該移動の開始に起こった災害の処理については、終点たる事業場の保険関係で行うものとされている(労働基準局長通達(平城18年3月31日基発第0331042号))。



る場合があるし、雇用類似者が経済的従属性を維持していることもある。よって、一定規模以上の取引を行う発注者や業務管理者を名宛人として、法第3条第3項類似の規定と共に、安易な契約切りを防止すべき旨の規定を設けると共に、上述した連帯支援策、内部監査制度、行政による救済制度、発注者や業務管理者による業務上の健康リスクの調査と対応策（リスクアセスメントに基づくリスク管理）等を、法定すべきであろう。判明したリスクへの対応策には、雇用類似者へのリスクの内容と対応策の伝達も含まれよう。

なお、メンタルヘルス対策や治療と就労の両立支援政策を典型として、安全衛生法政策が、就業者の働き方や生き方に介入している情勢に照らせば、雇用類似者の生活者への対応まで射程に入れることも検討に値する。既に地方自治体等が設置しているインキエーションオフィスに安全衛生にかかる予算を拠出し、宿泊施設、食事、融資者とのマッチング等、企業等の福利厚生に相当する便宜を提供したり、健康管理の施設と仕組みを設置すること等が考えられよう。

## 5. 法定の安全衛生管理体制との関係

上述した通り、法定の安全衛生管理体制の整備は、現行安衛法の特徴の1つであり、特に重篤な労災について、大きな防止効果をもたらした要素とも解され

る。そこで、副業・兼業、フリーランスへの適用の可能性について、改めて論じる。

周知のように、現行安衛法は、直接的な労使関係について、事業者という新たな概念を設定して、当該事業場の経営責任者に同法の執行責任を負わせると共に、彼/彼女らに、安全・衛生管理者、産業医など、安全衛生に詳しい者を活用させたり、1カ所で元請以下、複数の関係請負人が建設工事等労災リスクが高い業務を行う場については、統括安全衛生責任者制度、店社安全衛生管理者制度などを設け、業者間の連絡・連携を図らせ、巡視をさせ、安全衛生教育を支援させる等の労災防止活動に当たらせるなど、リスク関連情報を取得できる立場や、実質的な支配管理可能性等に基づき、労働者と労働契約関係にある事業者以外の者（元請け事業者等）にも労災リスクの管理責任を負わせてきた。

その趣旨を展開すれば、やはり、副業・兼業者、フリーランス等のいずれについても、その指示を行った者はもちろん、彼/彼女らの心身のリスクに関する情報や支配管理権限を持つ者、すなわち、発注者や業務管理者ないし勤務条件設定者を名宛人とすること<sup>11)</sup>、現行安衛法第3条第3項、建設工事従事者の安全及び健康の確保の推進に関する法律第3条や第6条をアレンジし、一定の法的拘束力を持たせた規定を設けることが有効と思われる。具体的には、一定規模以上の取引を行う発注者らに対して、業務

内注リスクの調査義務を課すと共に、行政から典型的なリスクについて手引きを公表し、フリーランス等については、委託内容、委託期日、報酬、支払期日等を手帳で管理させると共に、雇用類似者からの求めがあれば、行政官が調査し、必要に応じ、適当な措置を指導・勧告ないし命令できるとも、威迫的な効果（実際に発動しなくても、雇用類似者が見込まれる）。合わせて、雇用類似者の健康管理や委託条件の適正化に関する監査委員会を設置させると共に、行政において、そうした問題に関する苦情処理兼相談センターを設置し、ADR機能を果たせることも検討に値しよう。

## 6. 安衛法が想定するリスク要因との関係

上述したように、安全衛生法政策は、業務に内在するリスクへの対策を基本的な使命としているので、以下に、既存の安衛法の想定してきた代表的なリスクと対策を列挙し、新たな促進策との関係で、過不足を確認する。

法第20条から第24条は、以下のようなリスクを示している。

法第20条：機械、化学物質、電気等エネルギー等による諸種の危険  
法第21条：掘削、採石、荷役、伐木等の作業方法から生じる危険、墜落、土砂崩壊等の作業場所にかかる災害の危険

法第22条：原材料、ガス、蒸気、粉じん等の化学的要因、放射能、高温、騒音、振動等の物理的要因、計器監視、精密工作等の精神的要因、廃棄、廃液、残滓物等の有害・汚染要因による健康障害の危険  
法第23条：通路、床面、換気、採光、照明、風紀等の不備にかかる健康障害、風紀の乱れ等の危険  
法第24条：労働者の作業行動に起因する災害の危険

元労働行政にあって、労働安全衛生に詳しい藤森和幸氏は、現行法の想定する危険源を大別すると、人的要因、物的要因、作業・環境要因の3種になり、以下のように整理できるとしている<sup>12)</sup>。

①人的要因（作業者の知識・認識・意識不足、疲労・加齢・疾病・睡眠不足・飲酒、職場のコミュニケーション・管理者のリーダーシップの不足等）  
法定された基本的対策：安全衛生管理体制の構築、労働者本人の雇入れ時、危険作業従事前等の安全衛生教育、作業主任者、職長等への教育等。  
②物的要因（設計上の問題、防護策の不備、点検の不備等）

法定された基本的対策：機械等に関する規制として、製造許可、製造時の検査、検査を受けない機械の譲渡制限、設置時の検査、定期自主検査、取扱者の制限等。化学物質に関する規制として、製造等の禁止ないし許可制度、有害物の表示等、化学物質の有害性等に関する事業

11) UberやUber-Eatsなどが、発注者とは別に業務の調整・管理を行う者を設定し、就業者の就業条件を支配管理していることについて、浜村彰「プラットフォームエコノミーと労働法上の課題」労働調査577号（2018年）4-12頁などを参照されたい。

12) 厚生労働科学研究費補助金【労働安全衛生総合研究事業】「労働安全衛生法の改正に向けた法学的視点からの調査研究報告書（令和元年版）」（研究代表者：三柴文典）533頁。

者らへの情報提供、化学物質の危険有害性に関する調査等。

③作業・環境要因（不適切な作業方法、作業姿勢・動作の不良、作業空間の不良、作業環境の不良等）

法定された基本的対策：作業環境の測定、ばく露度の測定、健診、有害物質の排気等による危険源の除去、作業姿勢や動作、空間に関する基準設定、労働者本人及び作業主任者等への安全衛生教育等。

（副業・兼業者について）

副業・兼業者の場合、事業場や生産現場で就業する限り、上記のような、安衛法が既に想定しているリスクに晒されることは、本業のみに従事する労働者と同様でありなく、個々の事業者が、同法の危害防止基準の遵守等を通じて対策を図るべきである。

もつとも、移動の負担、本業先との連携がなされないことに伴う健康障害リスク、作業環境等の労働条件の差など、その副業・兼業に特有のリスクについては、本業先と副業・兼業先の連携を促す担当者を選任させるなどして、調査と対応を行わせる必要がある。

また、労働者の副業・兼業実態、使用者が認識しにくい就業上のリスクについて自己申告を行う機会を提供までは法令で使用者に求め、それでも捕捉しがたい副業・兼業実態や就業上のリスクについて

ては、産業医等による面談を行わせて捕捉を図る。産業医等が面談で知り得た副業・兼業実態について、本人が望めば、事業者には伝えず、求められる就業上の配慮のみを伝えさせる方途も考えられる。

（雇用類似者について）

上述した通り、フリーランス等の雇用類似者については、生じ得るリスクが、通常の労使関係下の労働とは異なることが多く、健康リスクであれば、本人の引き受けが原則となるが、発注者がリスクを創出しているか、その情報と支配管理権限を持っている限り、機械、化学物質などを含め、委託する業務に内在するリスクについては、発注者や業務管理者らに調査、対応させるべきだろう。また、生活不安、仕事の質的等にかかると健康リスクについても、社会的なセーフティネットとして<sup>13)</sup>、一定規模以上の取引を行う発注者等を対象として、調査及び対応可能な仕組みを法定すべきだろう。

## 7. 法定健診制度等との関係

副業・兼業、フリーランスにかかると主たる業務内在リスクが、長時間労働、長時間労働以外の疲労・ストレス要因による健康障害だとすれば、生活習慣病の検査項目を含む法定健診制度や、ストレスナ

13) ドイツでは、デジタル・プラットフォーム・エコノミーの発展を踏まえ、労使協議を通じて、独立自営業者への社会的な保護施策が計画されてきた。詳細は、山本陽大「第四次産業革命による働き方の変化と労働法政策上の課題～ドイツにおける「労働4.0」ホワイト・ペーパーが提起するもの」ビジネス・レビュー・トレンド2017年8・9月号46-53頁、労働政策研究・研修機構「『労働者』の法的概念：7か国の比較法的考察（労働政策研究報告書No.18）」（2005年）6-13頁（ロルフ・ヴァンク執筆、皆川宏之翻訳・改題部分）などを参照されたい。

ック制度のほか、長時間労働者対象の面接指導制度の適用のありようが、重要な意味を持つ。そこで以下、この点について論じる。

1) 法定健診・ストレスチェック制度の適用のありよう

法定健診・ストレスチェック制度の適用は、常時使用労働者（いわゆる正社員のフルタイム）、並びに、無期契約もしくは1年以上の契約期間を経過したか見込まれる有期契約で、同種業務に就く通常の労働者の週所定労働時間の4分の3以上働くパートタイム労働者等を対象とすることとなっている（平成26年7月24日付基発0724第2号等）。筆者は、副業・兼業者への適用も、この基準によって行えば良いと考ええる。

通常は考え難いが、仮に、この基準に拠っても2箇所以上で実施義務が生じるようであれば、各勤務先が健診・検査の実施義務を負うことややむを得ないのではなかろうか。この際、複数箇所が常時使用労働者かそれに類する就労をしているのであれば、過重労働となっていてい可能性が高い。間診票で、副業・兼業の無いしレジャーでの労働時間数、他で健診を受けているかを確認するなどしつつ、その点に關する情報は、健診実施事業者限りとし、本人の個別同意がない限り、原則として事業者には伝達しないことを保障し、ただし、健診を実施した者が、適切な問診と本人への保健指導、求められる就業上の配慮の事業者への伝達等を行える仕組みの構築が求められよう。

フリーランス等の雇用類似者について

は、労基法上の労働者に該当しない限り、法定健診やストレスチェック制度は適用されないが、健診としては、自治体による地域保健制度や、職業別の健康保険組合が実施するもの、特定健康診査及び特定保健指導制度、あんしん財団による補助制度などがあるもので、積極的に案内すべきだろう。ストレスチェック制度についても、今後、常時使用従業員数50人未満の事業場への適用の拡大を考えると、希望者については、検査と、高ストレス者に該当すれば面接指導が無償ないし安価で受けられるような制度を設けるべきだろう。ただし、現在労働者である者をフリーランス等に就かせるよう政策的に誘導するならば、法定の健診制度、ストレスチェック制度共に、職域対象の制度である産業保健総合支援センターに担わせる方が、一貫するよう思われる。

2) 長時間労働者向け面接指導制度の適用のありよう

周知のように、長時間労働者向け面接指導制度は、平成17年の安衛法改正（法律第108号）で設けられ、先般の働き方改革推進法による法改正により、充実にされた。週40時間を基準として、休憩時間を除き80時間/月以上の法定時間外労働を行った労働者から面接指導の申し出があった場合には、事業者は、当該労働者に医師による面接指導を受けさせる義務を負う。企業で新商品の開発を行う者など、従前から時間外労働に上限が設けられていなかった研究開発業務従事者や、先般の働き方改革推進法により新設され、高額な収入と業務遂行上の裁量権



を認められた高度プロフェッショナル制の対象者については、休憩時間を除き週40時間を超える時間外労働や健康管理時間が100時間を超えた場合、本人からの申し出がなくても、医師による面接指導を受けさせねばならない。また、こうした面接指導制度へのリンクを確実に行うべきため、時間把握を確実に行うべき業務も法定され、IC技術の活用なども推奨されている<sup>14)</sup>。

では、長時間労働を行った者を、確実に医師の面接指導に結びつけ、疲労・ストレスの度合いや質を調査させるという制度趣旨を、副業・兼業、フリーランス等にどう反映させるべきか。

副業・兼業者については、法定時間外労働が80時間/月以上を原則とする現行基準を前提に、対象者選定のための労働時間の把握は、使用者の指示による副業・兼業であれば、タイムカード、ICTなどを用いて、使用者の責任で把握させ、そうでない場合、労働者に自己申告

8. おわりに

原点に立ち返り、ドライな言い方をすれば、そもそも世の中、不自由を我慢する代わりに守ってもらおうか、自由を受け取る代わりに「死して屍拾う者なし」か、どちらかの選択が基本だろうと思う。特に優秀な人物（の集まる組織）であれば、何らかの審査を通過して特権的な立場であれば、ある程度、その両者のメリットを享受できるというに過ぎない。そこを曖昧にしても仕方がない。

日本人には、前者を選ぶ者が多かったが、今は、政治が後者を促進しようとしている。近い将来を考えても、個々の就業者の知的、感情的な付加価値を高めないと国が成り立たないのだから、必然ともいえるが、日本人の国民性があるし、経営者も従業員を結束させるのに並々ならぬ苦勞をしているから、前者を壊すことが良いとも思えない。

イメージとして、当面は、前者8割、後者2割程度を目標とするのが妥当なようにも思われる。労働安全衛生政策も、そうしたマクロの流れを後押しする役割は免れないだろう。もつとも、職域を焦点とした社会的なセーフティネットの構築のみならず、領域独自の哲学と戦略をもって臨む必要があると考える。

労働安全衛生は、業務に内在する心身のリスク対策を基本的な使命としているが、メンタルヘルズ対策や生活習慣病対策、がん患者の就労支援などを典型として、今や、働き方や生き方そのものに入入るようになってきている。すなわち、リスクと捉えらるべきか否か自体が疑

問な課題への対応のあり方が問われている。そうであれば尚更に、規制にもメリハリと柔軟性を持たせ、個人と組織の両方が、主体的な生き方を模索できるようにする必要がある。規制が発達するほど、規制の趣旨を踏まえつつ、自律的に生きる方法を探索し、開発する必要がある。産業保健政策では尚更に、労働時間・就業時間についても、一律ではない、質的な規制が求められる。なおかつ、規制内容と遵守の手段をシンプルにする必要がある。

他方で、原点復帰とモデル・チェンジの視点に立って、従前の安全衛生政策における積み残し課題への対応を進める必要もある。特に、業務内在リスクへの対応は、リスクの情報と支配管理権限を持つ者に委ねるべきというリスク創出者管理責任負担原則の展開は、新たな促進策において、安全衛生法政策上の重要課題になると解される。その手始めは、建設業にとどまらない一人親方に対する、一定規模以上の取引を行う発注者や業務管理者の災害リスク管理責任の設定ではないかと思われる。

### 副業・兼業に係る実態把握の内容等について

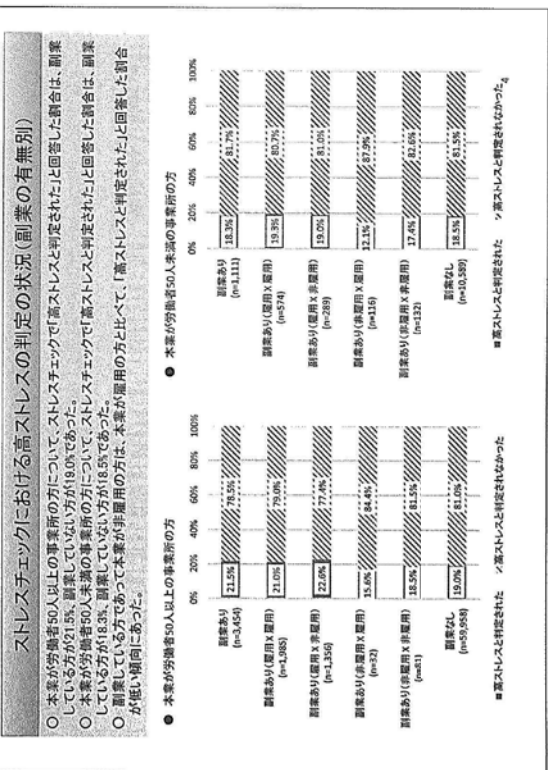
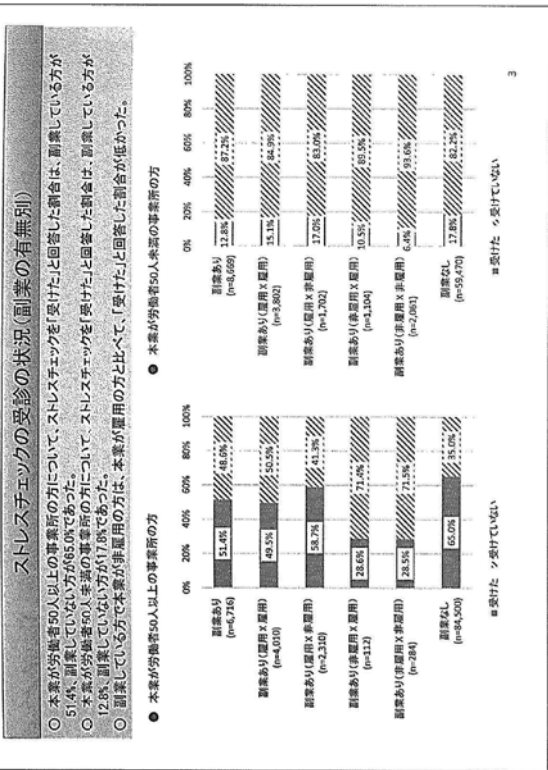



### 高ストレスと判定された方への面接指導の有無別

○ 本業が労働者50人以上の事業所の方で、ストレスと判定された方への面接指導の有無別について、「受けたい」と回答している方が18.8%、「受けたくない」と回答している方が81.2%であった。  
 ○ 1カ月前に面接指導を受けた方では、高ストレスと判定された方への面接指導を受けたことを希望した割合は、面接指導を受けた方では14.3%、面接指導を受けないことを希望した割合は71.7%であった。  
 ○ 面接指導を受けないことを希望した方では、高ストレスと判定された方への面接指導を受けたことを希望した割合は、面接指導を受けた方では14.3%、面接指導を受けないことを希望した割合は71.7%であった。

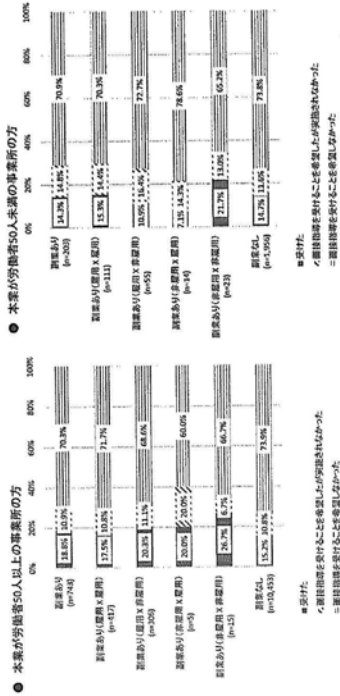

### 副業をしている理由(労働時間別)

○ 副業をしている理由について、全ての層で「1つの仕事だけでは収入が少なすぎて、生活費が足りないから」、「収入を増やしたいから」との回答が3割を超えている。

労働時間	収入を増やしたいから	生活費が足りないから	1つの仕事だけでは収入が少なすぎて、生活費が足りないから	収入を増やしたいから	生活費が足りないから	1つの仕事だけでは収入が少なすぎて、生活費が足りないから
10時間未満 (n=2,160)	37.9%	32.2%	29.9%	37.9%	32.2%	29.9%
10~19時間未満 (n=1,705)	31.1%	25.2%	43.7%	31.1%	25.2%	43.7%
20~29時間未満 (n=1,060)	21.5%	18.8%	59.7%	21.5%	18.8%	59.7%
30~39時間未満 (n=430)	15.1%	13.7%	71.2%	15.1%	13.7%	71.2%
40~49時間未満 (n=199)	11.6%	10.6%	77.8%	11.6%	10.6%	77.8%
50時間以上 (n=339)	10.3%	9.4%	80.3%	10.3%	9.4%	80.3%

※ 各層は30%以上の割合

### 副業をしている人の割合(労働時間別)

○ 副業をしている人の割合は全体で9.7%であり、1カ月前の調査では19.0%と最も高く、「160~200時間未満」が5.3%と最も低かった。

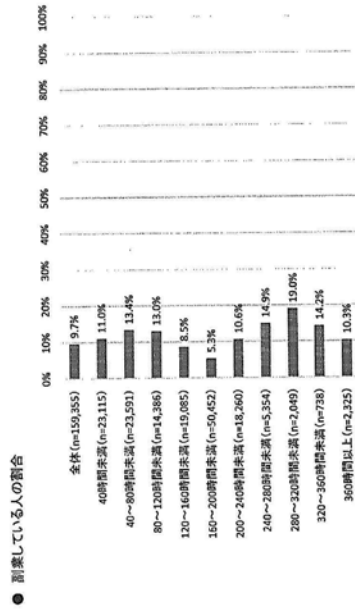

※ 1カ月前の本業・副業を含めた総労働時間別

### 副業をしている方の強い不安、悩み、ストレスの状況(労働時間別)

○ 本業における強い不安、悩み、ストレスについては、「収入が低いこと」、「対人関係(セハラ、ハラスモ含む)」、「通勤」の割合が高かった。  
 ○ 副業における強い不安、悩み、ストレスについては、「副業に慣れないこと」、「副業に慣れないこと」の割合が高かった。

労働時間	収入が低いこと	対人関係(セハラ、ハラスモ含む)	通勤	副業に慣れないこと	副業に慣れないこと
10時間未満 (n=2,160)	11.1%	11.1%	11.1%	11.1%	11.1%
10~19時間未満 (n=1,705)	11.1%	11.1%	11.1%	11.1%	11.1%
20~29時間未満 (n=1,060)	11.1%	11.1%	11.1%	11.1%	11.1%
30~39時間未満 (n=430)	11.1%	11.1%	11.1%	11.1%	11.1%
40~49時間未満 (n=199)	11.1%	11.1%	11.1%	11.1%	11.1%
50時間以上 (n=339)	11.1%	11.1%	11.1%	11.1%	11.1%

※ 1カ月前の本業・副業を含めた総労働時間別

不安、悩み、ストレスを相談できる人がいるか(労働時間別)

○ 不安、悩み、ストレスを相談できる人がいると回答した割合は、副業をしている方で「320～360時間未満」の方が49.3%と最も高かった。  
 ○ 副業時間が「16時間以上6時間未満」であると同答した割合は、副業をしていない方で「280～320時間未満」の方が49.3%と最も高かった。

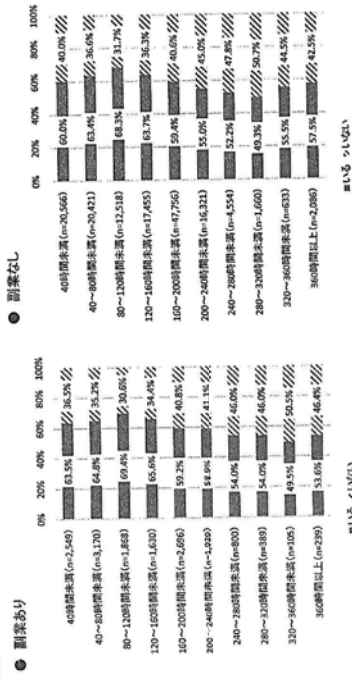

※ 1か月あたりの本業・副業を合わせた総労働時間別

不安、悩み、ストレスの相談環境の整備の希望の有無(労働時間別)

○ 不安、悩み、ストレスを相談できる人がいないと回答した方の中、相談環境の整備を希望する(本業先や時間帯で相談できること)を希望しない割合は、副業をしている方で「280～320時間未満」の方が20.1%と最も高く、副業をしていない方で「200～240時間未満」の方が19.3%と最も高かった。  
 ○ 不安、悩み、ストレスを相談できる人がいないと回答した方の中、相談環境の整備を希望する(副業先・時間帯・相談先は関係ない)希望を相談できることを希望し、回答した割合は、副業をしている方で「160～200時間未満」が30.5%と最も高く、副業をしていない方で「200～240時間未満」の方が35.7%と最も高かった。

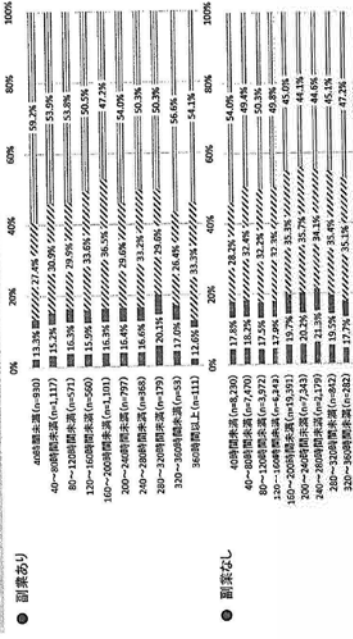

※ 1か月あたりの本業・副業を合わせた総労働時間別

睡眠時間(労働時間別)

○ 睡眠時間が「6時間未満」であると回答した割合は、副業をしている方で「360時間以上」の方が29.7%と最も高く、副業をしていない方で「280～320時間未満」の方が22.0%と最も高かった。  
 ○ 睡眠時間が「16時間以上6時間未満」であると回答した割合は、副業をしていない方で「280～320時間未満」の方が39.3%と最も高く、副業をしていない方で「240～280時間未満」の方が42.4%と最も高かった。

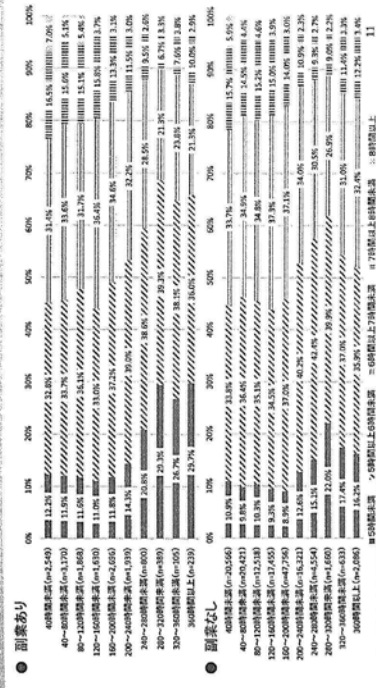

※ 1か月あたりの本業・副業を合わせた総労働時間別

病気による休みの状況(労働時間別)

○ 過去1年間に病気のために仕事を休んだことがあると回答した割合は、副業をしている方で「200～240時間未満」の方が27.2%と最も高く、副業をしていない方で「160～200時間未満」の方が25.6%と最も高かった。

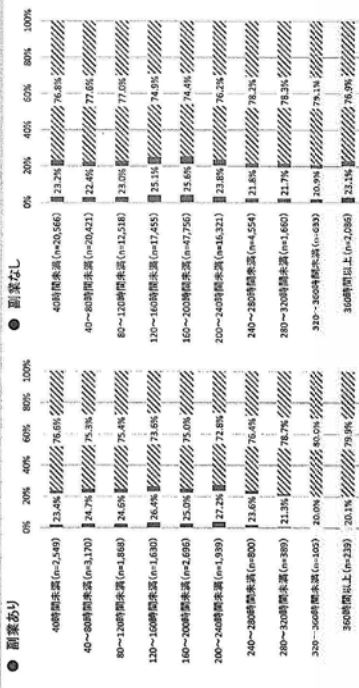

※ 1か月あたりの本業・副業を合わせた総労働時間別



健康診断の受診の状況(労働時間別)

○ 一般健康診断を「受診した」と回答した割合は、副業をしている方では「200～240時間未満」の方が73.0%と最も高く、「80～120時間未満」の方が39.1%と最も低かった。また、副業をしない方では「160～200時間未満」の方が84.8%と最も高く、「80～120時間未満」の方が48.7%と最も低かった。

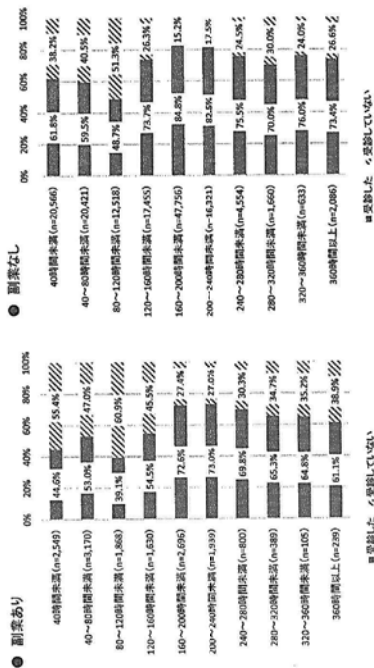

※ 19月ありの本業・副業を含めた総労働時間別

健康診断後の就業上の措置の状況(労働時間別)

○ 一般健康診断で「有病」となった方への就業上の措置の状況について、副業の有無や労働時間に関わらず、「何も対応は受けていない」と回答した割合が最も高く、次に「保健師等による保健指導」と回答した割合が高かった。

労働時間	何も対応は受けていない (%)	保健師等による保健指導 (%)	就業上の措置を講じた (%)	その他 (%)
40時間未満 (n=2,543)	29.0%	3.3%	2.7%	64.0%
40～80時間未満 (n=3,170)	29.5%	0.9%	1.7%	67.9%
80～120時間未満 (n=1,821)	28.6%	0.8%	1.3%	69.3%
120～160時間未満 (n=1,998)	28.7%	0.9%	0.7%	69.7%
160～200時間未満 (n=2,723)	22.4%	0.9%	1.6%	75.1%
200～240時間未満 (n=2,552)	36.3%	1.3%	0.7%	61.7%
240～280時間未満 (n=2,247)	32.9%	0.8%	1.2%	65.1%
280～320時間未満 (n=1,099)	25.3%	3.0%	2.0%	69.7%
320～360時間未満 (n=272)	34.8%	0.0%	3.7%	61.5%
360時間以上 (n=1,443)	31.8%	1.5%	1.7%	65.0%
40～80時間未満 (n=3,969)	24.0%	1.0%	1.4%	73.6%
80～120時間未満 (n=4,143)	27.1%	0.9%	0.8%	71.2%
120～160時間未満 (n=4,143)	30.1%	0.4%	0.6%	68.9%
160～200時間未満 (n=5,213)	18.6%	0.4%	0.6%	80.4%
200～240時間未満 (n=4,113)	32.6%	1.0%	0.8%	65.6%
240～280時間未満 (n=4,513)	30.7%	1.6%	0.4%	67.3%
280～320時間未満 (n=1,643)	34.4%	0.6%	3.0%	62.0%
320～360時間未満 (n=572)	33.5%	1.0%	0.7%	64.8%
360時間以上 (n=2,124)	31.0%	0.7%	1.0%	67.3%

※ 17月ありの本業・副業を含めた総労働時間別

健康診断の有所見の状況(労働時間別)

○ 一般健康診断で「所見あり」と回答した割合は、副業をしている方では「240～280時間未満」の方が41.9%と最も高く、「80～120時間未満」の方が44.3%と最も高かった。

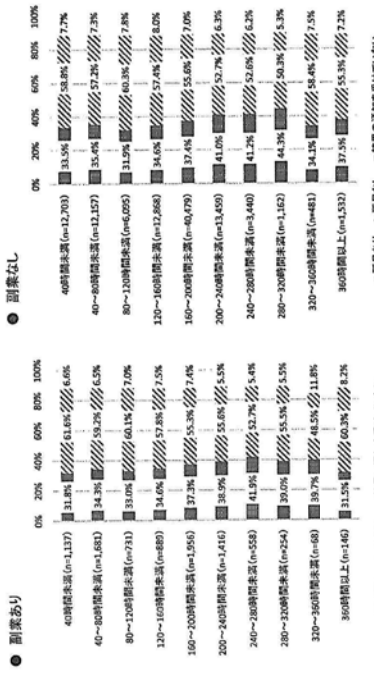

※ 17月ありの本業・副業を含めた総労働時間別

ストレスチェックの受診の状況(労働時間別)

○ ストレスチェックを「受けた」と回答した割合は、副業をしている方では「160～200時間未満」の方が38.8%と最も高く、「80～120時間未満」の方が18.5%と最も低かった。また、副業をしない方では「160～200時間未満」の方が56.0%と最も高く、「80～120時間未満」の方が24.7%と最も低かった。

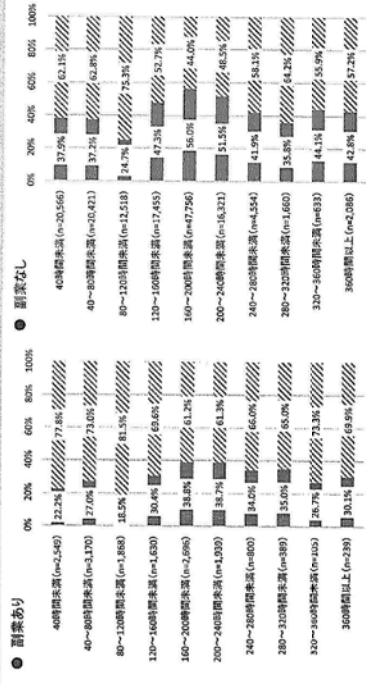

※ 17月ありの本業・副業を含めた総労働時間別

ストレスチェックにおける高ストレスの判定の状況(労働時間別)

○ ストレスチェックで高ストレスと判定された」と回答した割合は、副業をしている方では「240～280時間未満」の方で34.9%と最も長かった。

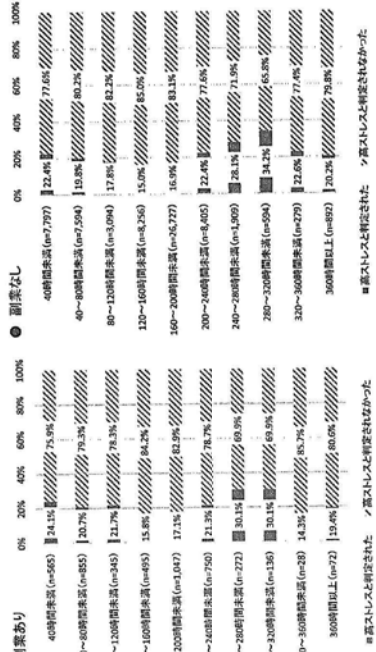

高ストレスと判定された方への面接指導の状況(労働時間別)

○ ストレスチェックの結果、高ストレスと判定された方の面接指導の受診状況について、「受けた」と回答した割合は、副業をしている方では「40時間未満」の方で43.3%と最も高く、「280～320時間未満」の方で42.5%と最も長かった。また、副業していない方では「80時間以上」の方が21.4%と最も高く、副業していない方で「360時間以上」の方が15.6%と最も長かった。

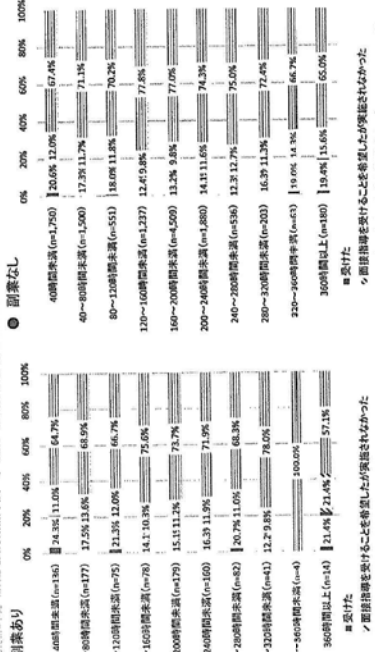

副業している方の健康診断の受診者数(就業形態別)

就業形態	健康診断の受診者数									
	正社員	パート・アルバイト	パート・アルバイト	パート・アルバイト	パート・アルバイト	パート・アルバイト	パート・アルバイト	パート・アルバイト	パート・アルバイト	パート・アルバイト
正社員	532	206	1395	179	19	44	87	90	1109	265
パート・アルバイト	703	233	3925	217	26	53	95	131	1331	312
パート・アルバイト	5	174	301	63	7	10	6	76	25	180
パート・アルバイト	5	267	405	69	8	12	6	50	75	57
パート・アルバイト	2	36	1184	53	4	15	7	45	41	238
パート・アルバイト	2	81	3132	175	10	35	15	102	31	657
パート・アルバイト	0	0	11	2	0	0	0	3	0	4
パート・アルバイト	1	14	135	75	1	11	2	13	2	64
パート・アルバイト	2	21	242	101	2	10	2	10	5	105
パート・アルバイト	18	15	38	1	1	7	3	20	52	3
パート・アルバイト	27	20	101	3	3	116	67	3	8	27
パート・アルバイト	15	28	182	20	0	2	104	217	7	85
パート・アルバイト	2	68	425	45	1	13	21	519	27	244
パート・アルバイト	4	21	82	13	1	2	7	27	5	262
パート・アルバイト	5	37	45	2	5	16	73	13	86	32
パート・アルバイト	0	0	7	0	0	0	0	0	1	6
パート・アルバイト	0	0	2	0	0	0	0	0	2	15
パート・アルバイト	2	1	10	3	0	0	0	3	4	2
パート・アルバイト	2	5	31	3	0	2	5	4	4	32

副業している方のストレスチェックの受診者数(就業形態別)

就業形態	ストレスチェックの受診者数									
	正社員	パート・アルバイト	パート・アルバイト	パート・アルバイト	パート・アルバイト	パート・アルバイト	パート・アルバイト	パート・アルバイト	パート・アルバイト	パート・アルバイト
正社員	302	134	855	103	14	30	51	225	51	674
パート・アルバイト	703	233	3925	217	26	53	95	131	105	1331
パート・アルバイト	3	108	204	43	5	9	3	51	15	123
パート・アルバイト	3	267	405	69	8	12	6	50	25	227
パート・アルバイト	1	28	545	35	4	5	5	25	20	118
パート・アルバイト	0	81	3132	175	10	35	15	102	31	657
パート・アルバイト	0	0	11	2	0	0	0	3	0	2
パート・アルバイト	0	5	79	42	1	7	1	9	0	57
パート・アルバイト	2	21	242	101	2	10	2	10	5	105
パート・アルバイト	7	4	16	0	0	1	23	11	0	12
パート・アルバイト	27	20	101	3	3	116	67	3	8	27
パート・アルバイト	27	20	101	3	3	116	67	3	8	27
パート・アルバイト	15	28	182	20	0	2	104	217	7	85
パート・アルバイト	2	68	425	45	1	13	21	519	27	244
パート・アルバイト	4	21	82	13	1	2	7	27	5	262
パート・アルバイト	5	37	45	2	5	16	73	13	86	32
パート・アルバイト	0	0	7	0	0	0	0	0	1	6
パート・アルバイト	0	0	2	0	0	0	0	0	2	15
パート・アルバイト	2	1	10	3	0	0	0	3	4	2
パート・アルバイト	2	5	31	3	0	2	5	4	4	32



## 参考資料

### 副業・兼業の促進に関するガイドライン

#### 1. 副業・兼業の現状

- (1) 副業・兼業を希望する者は年々増加傾向にある。副業・兼業を行う理由は、自分がやりたい仕事であること、スキルアップ、資格の活用、十分な収入の確保等さまざまであり、また、副業・兼業の形態も、正社員、パート・アルバイト、会社役員、起業による自営業主等さまざまである。
- (2) 多くの企業では、副業・兼業を認めていない。企業が副業・兼業を認めるにあたっての課題・懸念としては、自社での業務がおろそかになること、情報漏洩のリスクがあること、競業・利益相反になること等が挙げられる。また、副業・兼業に係る就業時間や健康管理の取扱いのルールが分かりにくいとの意見がある。
- (3) 副業・兼業自体への法的な規制はないが、厚生労働省が平成29年12月時点で示しているモデル就業規則では、労働者の遵守事項に、「許可なく他の会社等の業務に従事しないこと」という規定がある。
- (4) 裁判例では、労働者が労働時間以外の時間をどのように利用するかは、基本的には労働者の自由であり、各企業においてそれを制限することが許されるのは、労務提供上の支障となる場合、企業秘密が漏洩する場合、企業の名誉・信用を損なう行為や信頼関係を破壊する行為がある場合、競業により企業の利益を害する場合と考えられる。

#### 2. 副業・兼業の促進の方向性

- (1) 副業・兼業は、労働者と企業それぞれにメリットと留意すべき点がある。

#### 【労働者】

##### メリット：

- ① 離職せずとも別の仕事に就くことが可能となり、スキルや経験を得ることで、労働者が主体的にキャリアを形成することができる。
- ② 本業の所得を活かして、自分がやりたいことに挑戦でき、自己実現を追求することができる。
- ③ 所得が増加する。
- ④ 本業を続けつつ、よりリスクの小さい形で将来の起業・転職に向けた準備・試行ができる。

##### 留意点：

- ① 就業時間が長くなる可能性があるため、労働者自身による就業時間や健康の管理も一定程度必要である。

1

- ② 職務専念義務、秘密保持義務、競業禁止義務を意図することが必要である。
- ③ 1週間の所定労働時間が短い業務を複数行う場合には、雇用保険等の適用がない場合があることに留意が必要である。

#### 【企業】

##### メリット：

- ① 労働者が社内では得られない知識・スキルを獲得することができる。
- ② 労働者の自律性・自主性を促すことができる。
- ③ 優秀な人材の獲得・流出の防止ができ、競争力が向上する。
- ④ 労働者が社外から新たな知識・情報や人脈を入れることで、事業機会の拡大につながる。

##### 留意点：

- ① 必要な就業時間の把握・管理や健康管理への対応、職務専念義務、秘密保持義務、競業禁止義務をどう確保するかという懸念への対応が必要である。

(2) また、副業・兼業は、社会全体としてみれば、オープンイノベーションや起業の手段としても有効であり、都市部の人材を地方でも活かすという観点から地方創生にも資する面もあると考えられる。

(3) これらを踏まえると、労働者が副業・兼業を行う理由は、自分がやりたい仕事であること、十分な収入の確保等さまざまであり、業種や職種によって仕事の内容、収入等も様々な実情があるが、自身の能力を一企業にとらわれずに幅広く発揮したい、スキルアップを図りたいなどの希望を持つ労働者がいることから、こうした労働者については、長時間労働、企業への労務提供上の支障や企業秘密の漏洩等を招かないよう留意しつつ、雇用されない働き方も含め、その希望に応じて幅広く副業・兼業を行える環境を整備することが重要である。

また、いずれの形態の副業・兼業においても、長時間労働にならないよう、以下の3～5に留意して行われることが必要である。

なお、労働基準法の労働時間規制を潜脱するような形態や、合理的な理由なく労働条件を労働者の不利益に変更するような形態で行われる副業・兼業は、認められない。

#### 3. 企業の対応

- (1) 裁判例を踏まえれば、原則、副業・兼業を認める方向とすることが適当である。副業・兼業を禁止、一律許可制にしている企業は、副業・兼業が自社での業務に支障をもたらすものかどうかを今一度精査したうえで、そのような事情がなければ、労働時間以外の時間については、労働者の希望に応じて、原則、副業・兼業を認める方向で検討することが求められる。

2

また、実際に副業・兼業を進めるにあたっては、労働者と企業双方が納得感を持つて進めることができるよう、労働者と十分にコミュニケーションをとることが重要である。

(2) 副業・兼業を認める場合、労務提供上の支障や企業秘密の漏洩等がないが、また、長時間労働を招くものとなっていないか確認する観点から、副業・兼業の内容等を労働者に申請・届出させることも考えられる。

その場合も、労働者と企業とのコミュニケーションが重要であり、副業・兼業の内容等を示すものとしては、当該労働者が副業・兼業先に負っている守秘義務に留意しつつ、例えば、自己申告のほか、労働条件通知書や契約書、副業・兼業先と契約を締結する前であれば、募集に関する書類を活用することが考えられる。

(3) 特に、労働者が、自社、副業・兼業先の両方で雇用されている場合には、労働時間に関する規定の適用について通算するとされていることに留意する必要がある。また、労働時間や健康の状況を把握するためにも、副業・兼業の内容等を労働者に申請・届出させることが望ましい。

(4) 各企業における検討にあたっては、今般、厚生労働省が改定したモデル就業規則の規定を参照することができる。

#### ※1 就業時間の把握について

・労働基準法第38条では「労働時間は、事業場を異にする場合においても、労働時間に関する規定の適用については通算する。」と規定されており、「事業場を異にする場合」とは事業主を異にする場合をも含む。(労働基準局長通達(昭和23年5月14日基発第769号))

・使用者は、労働者が労働基準法の労働時間に関する規定が適用される副業・兼業をしている場合、労働者からの自己申告(4(3)参照)により副業・兼業先での労働時間を把握することが考えられる。

・個人事業主や委託契約・請負契約等により労働基準法上の労働者でない者として、または、労働基準法上の管理監督者として、副業・兼業を行う者については、労働基準法の労働時間に関する規定が適用されない。

なお、この場合においても、過労等により業務に支障を来さないようにする観点から、その者の自己申告により就業時間を把握すること等を通じて、就業時間が長時間にならないよう配慮することが望ましい。

#### ※2 健康管理について

・使用者は、労働者が副業・兼業をしているかにかかわらず、労働安全衛生法第66条等に基づき、健康診断等を実施しなければならない。

(注) 労働安全衛生法第66条に基づく一般健康診断及び第66条の10に基づくストレスチェックは、常時使用する労働者(常時使用する長時間労働者を含む。)が実施対象となる。この際、常時使用する長時間労働者とは、長時間労働者のうち、以下のいずれの要件をも満たす者となる(平成26年7月24日付基発0724第2号等抜粋)。

- ・ 期間の定めのない労働契約により使用される者(期間の定めのある労働契約により使用される者であって、契約期間が1年以上である者並びに契約更新により1年以上使用されることが予定されている者及び1年以上引き続き使用されている者を含む。)
- ・ 1週間の労働時間数が当該事業場において同様の業務に従事する通常の労働者の1週間の所定労働時間の3/4以上である者

・ 上記措置の実施対象者の選定にあたって、副業・兼業先における労働時間の通算は不要である。ただし、使用者が労働者に副業・兼業を推奨している場合は、労使の話し合い等を通じ、副業・兼業の状況も踏まえて、健康診断等の必要な健康確保措置を実施することが適当である。

・ また、副業・兼業者の長時間労働や不規則な労働による健康障害を防止する観点から、働き過ぎにならないよう、例えば、自社での労務と副業・兼業先での労務との兼ね合いの中で、時間外・休日労働の免除や抑制等を行うなど、それぞれの事業場において適切な措置を講じることができるよう、労使で話し合うことが適当である。

#### ※3 安全配慮義務について

労働者の副業・兼業先での働き方に関する企業の安全配慮義務について、現時点では明確な司法判断は示されていないが、使用者は、労働契約法第5条に、安全配慮義務(労働契約に伴い、労働者がその生命、身体等の安全を確保しつつ労働することができるよう、必要な配慮をする)が規定されていることに留意が必要である。

#### 4 労働者の対応

(1) 労働者は、副業・兼業を希望する場合にも、まず、自身が勤めている企業の副業・兼業に関するルール(労働契約、就業規則等)を確認し、そのルールに照らして、業務内容や就業時間等が適切な副業・兼業を選択する必要がある。また、実際に副業・兼業を行うにあたっては、労働者と企業双方が納得感を持つて進めることができるよう、企業と十分にコミュニケーションをとることが重要である。

(2) また、(1)により副業・兼業を行うにあたっては、副業・兼業による過労によつて健康を害したり、業務に支障を来したりすることがないよう、労働者(管理監督者である労働者も含む)が自ら、本業及び副業・兼業の業務量や進捗状況、それらに費やす時間や健康状態を管理する必要がある。

(3) そこで、使用者が提供する健康相談等の機会や、勤務時間や健康診断の結果等の管理が容易になるようなツールを用いることが望ましい。始業・終業時刻、休憩時間、勤務時間、健康診断等の記録をつけるような民間等のツールを活用して、自己の就業時間や健康の管理に努めることが考えられる。ツールは、副業・兼業先の就業時間を自己申告により使用者に伝えるときにも活用できるようなものが望ましい。

(4) なお、副業・兼業を行い、20万円を超える副収入がある場合は、企業による年末調整ではなく、個人による確定申告が必要である。

#### 5. 副業・兼業に関わるその他の現行制度について

##### (1) 労災保険の給付（休業補償、障害補償、遺族補償等）

事業主は、労働者が副業・兼業をしているかにかかわらず、労働者を1人でも雇用していれば、労災保険の加入手続を行う必要がある。

なお、労災保険制度は労働基準法における個別の事業主の災害補償責任を担保するものであるため、その給付額については、災害が発生した就業先の賃金分のみに基づき算定している。

また、労働者が、自社、副業・兼業先の両方で雇用されている場合、一の就業先から他の就業先への移動時に起こった災害については、通勤災害として労災保険給付の対象となる。

(注) 事業場間の移動は、当該移動の終点たる事業場において労務の提供を行うために行われる運動であると考えられ、当該移動の間に起こった災害に関する保険関係の処理については、終点たる事業場の保険関係で行うものとしている。(労働基準局長通達(平成18年3月31日基発第0331042号))

##### (2) 雇用保険、厚生年金保険、健康保険

雇用保険制度において、労働者が雇用される事業は、その業種、規模等を問わず、全て適用事業（農林水産の個人事業のうち常時5人以上の労働者を雇用する事業以外の事業については、暫定任意適用事業）である。このため、適用事業所の事業主は、雇用する労働者について雇用保険の加入手続を行わなければならない。ただし、同一の事業主の下で、①1週間の所定労働時間が20時間未満である者、②継続して31日以上雇用されることが見込まれない者については被保険者とならない（適用除外）。また、同時に複数の事業主に雇用されている者が、それぞれの雇用関係において被保険者要件を満たさず場合、その者が生計を維持するに必要な主たる賃金を受ける雇用関係についてのみ被保険者となる。

社会保険（厚生年金保険及び健康保険）の適用要件は、事業所毎に判断するため、複数の雇用関係に基づき複数の事業所で勤務する者が、いずれの事業所においても適用要件を満たさない場合、労働時間等を合算して適用要件を満たしたとしても、適用されない。また、同時に複数の事業所で就労している者が、それぞれの事業所で被保

険者要件を満たす場合、被保険者は、いずれかの事業所の管轄の年金事務所及び医療保険者を満たす場合、当該選択された年金事務所及び医療保険者において各事業所の報酬月額を合算して、標準報酬月額を算定し、保険料を決定する。その上で、各事業主は、被保険者に支払う報酬の額により按分した保険料を、選択した年金事務所に納付（健康保険の場合は、選択した医療保険者等に納付）することとなる。