

### Peg-IFN- $\alpha$

PEG is a water-soluble neutral molecule with no toxicity of itself. The number of ethylene oxide subunits determines the molecular weight. The aims of pegylating IFN are twofold: (i) to alter its *in vivo* pharmacodynamic properties; and (ii) protect the IFN molecule from recognition and elimination by the host immune defenses. Peg-IFN- $\alpha$  used in the treatment of chronic hepatitis C comes in the form of Peg-IFN- $\alpha$ -2a, with a 40-kD PEG branch chain covalently attached to IFN- $\alpha$ -2a, and Peg-IFN- $\alpha$ -2b, with a 12-kD PEG branch chain attached via a urethane bond to IFN- $\alpha$ -2b. They reach a maximum concentration ( $C_{max}$ ) at 72–96 and 15–44 h after administration, respectively, and after a single dose maintain plasma levels within the therapeutic range for approximately 168 and 80 h, respectively.<sup>24</sup> As the molecular weight of PEG attached to IFN in this way increases, the intracorporeal retention time also increases, although the pharmacological effect decreases in inverse proportion. The IFN activity of Peg-IFN- $\alpha$ -2a is 7% that of non-pegylated-IFN- $\alpha$ -2a, whereas the IFN activity of Peg-IFN- $\alpha$ -2b is 28% that of non-pegylated-IFN- $\alpha$ -2b, with the latter more active. Accordingly, the actual antiviral effect is determined in a complex fashion by the balance between intracorporeal retention time and IFN activity, as well as the patient's body type and weight. Peg-IFN- $\alpha$ -2a is approved as monotherapy and in combination with ribavirin for national medical insurance coverage, whereas Peg-IFN- $\alpha$ -2b is approved in combination with ribavirin with or without telaprevir.

The two forms of Peg-IFN- $\alpha$  have different standard doses. The standard dosage regimen for Peg-IFN- $\alpha$ -2a is fixed at 180  $\mu$ g/week, and the dose of Peg-IFN- $\alpha$ -2b varies according to the patient's weight, the standard dosage regimen being 1.5  $\mu$ g/kg per week.

### IFN- $\beta$

Interferon- $\beta$  is a natural IFN that can be used in a non-pegylated form, and is approved as monotherapy and in combination with ribavirin for medical insurance coverage. It is administered at least three times per week as an i.v. injection or i.v. infusion. Although IFN- $\beta$  binds to the same type I IFN receptor as IFN- $\alpha$ , and has a similar antiviral effect to IFN- $\alpha$ , their adverse reaction profiles differ. A retrospective study of natural human IFN- $\beta$  + ribavirin combination therapy in the treatment of 40 cases with genotype 1b HCV infections reported fewer discontinuations due to adverse reactions, and only mild decreases in platelet counts.<sup>25</sup> Even patients with a history of discontinuing IFN- $\alpha$  therapy due

to depression tolerated IFN- $\beta$  + ribavirin combination therapy well in terms of depressive symptoms and other adverse reactions.<sup>26–28</sup> IFN therapy with natural human IFN- $\beta$  is therefore recommended in patients in whom IFN- $\alpha$  therapy is not tolerated, for example, those with a history of depression.

Anti-IFN- $\alpha$  neutralizing antibodies were detected in 15% of non-responders to Peg-IFN- $\alpha$  + ribavirin therapy in one study.<sup>29</sup> Anti-IFN- $\alpha$  neutralizing antibodies do not block IFN- $\beta$  activity, so a changeover to natural human IFN- $\beta$  should be considered in cases of non-response to Peg-IFN- $\alpha$  + ribavirin due to these neutralizing antibodies.

Natural human IFN- $\beta$  can be administered twice daily in divided doses, providing a more potent antiviral effect than once daily dosing as measured by the HCV dynamics.<sup>30</sup> Divided dosing IFN- $\beta$  induction prior to Peg-IFN- $\alpha$  + ribavirin therapy has been trialed.<sup>31</sup>

### Antiviral effects of IFN<sup>32–34</sup>

IFN acts through binding to type I IFN receptors on the target cell membrane. Type I IFN receptors are common to IFN- $\alpha$  and IFN- $\beta$ , and binding of either IFN type to the receptor causes activation of the tyrosine-protein kinase, Janus kinase 1 (JAK1). This induces phosphorylation of tyrosine residues in the intracellular domain of the receptor, resulting in phosphorylation and formation of dimer complexes of signal transducer and activator of transcription 1 (STAT1), which transmit signal to the cell nucleus. This in turn induces and upregulates expression of IFN-stimulated genes (ISG). The family of ISG includes a wide variety of antiviral and immunoregulatory genes, and the antiviral effects of IFN are thought to derive from proteins induced by ISG.

### Adverse reactions

Adverse reactions to IFN therapy are experienced by almost all patients. The most common are influenza-like symptoms, such as general malaise, fever, headache and aching joints, and are reported by 60–95% of patients. Most influenza-like syndrome can be controlled with anti-inflammatory analgesic medication. Blood tests show leukopenia, with white blood cell counts <1000/ $\text{mm}^3$  seen in approximately 60% of patients. Serious infections associated with neutropenia are, however, considered rare.<sup>35</sup> White blood cell, neutrophil and platelet counts tend to decrease for the first 4 weeks of IFN therapy, then often remain stable without further decline. Neuropsychiatric symptoms such as depression and insomnia occur in 5–10% of patients, and are more

common in those with pre-existent neuropsychiatric symptoms or a history of depression.<sup>36</sup> Neuropsychiatric symptoms are classified into depression-specific symptoms and depression-related autonomic nervous symptoms, with selective serotonin re-uptake inhibitors (SSRI) reported to be useful in treating the former.<sup>37–39</sup> IFN can also trigger or aggravate autoimmune diseases such as chronic thyroiditis, so the utmost caution is required when administering IFN to patients with autoimmune diseases. Interstitial pneumonia, another reported adverse reaction to IFN therapy, can be serious and even life-threatening. It usually occurs after 2 months of therapy, or in the later stages of treatment. A rapid and appropriate management is required following the onset of respiratory symptoms such as a dry cough or dyspnea, including an immediate chest CT scan. Determination of serum KL-6 levels is also useful in the diagnosis of interstitial pneumonia. Other reported adverse reactions to IFN therapy include cardiomyopathy and fundal hemorrhage.

The adverse reaction profile of Peg-IFN differs somewhat to that of non-pegylated-IFN. In a Japanese clinical trial of Peg-IFN- $\alpha$ -2a monotherapy, the adverse reactions with a higher reported frequency than non-pegylated-IFN- $\alpha$ -2a were skin reactions such as erythema at the injection site and hematological reactions such as decreases in the white blood cell counts or platelet counts. On the other hand, mild to moderate adverse reactions such as influenza-like syndrome, including fever and joint pains, or malaise and loss of appetite, were milder than with standard non-pegylated-IFN- $\alpha$ -2a.<sup>40</sup>

#### Recommendations:

- 1 Reported adverse reactions to IFN therapy include influenza-like syndrome, decrease of blood cell counts, neuropsychiatric symptoms, autoimmune phenomena, interstitial pneumonia, cardiomyopathy and fundal hemorrhage.
- 2 Pegylation stabilizes serum IFN levels, ameliorating influenza-like syndrome such as fever and joint pains.
- 3 Patients self-injecting of natural human IFN- $\alpha$  at night minimizes influenza-like syndrome.
- 4 IFN- $\beta$  should be considered in patients unable to tolerate IFN- $\alpha$  due to depression or other causes.

#### Is there any difference between Peg-IFN- $\alpha$ -2a and Peg-IFN- $\alpha$ -2b therapeutic efficacy and adverse reactions?

In Japan at present, two Peg-IFN formulations are available for use in Peg-IFN + ribavirin therapy, Peg-IFN-

$\alpha$ -2a and Peg-IFN- $\alpha$ -2b. McHutchison *et al.* conducted a large multi-center study comparing the efficacy of these two agents. In this randomized controlled trial (RCT) conducted at 118 institutions, with 3070 patients with IFN-naive genotype 1 HCV infection, the SVR rate in the Peg-IFN- $\alpha$ -2a 180- $\mu$ g group was 40.9% and that in the Peg-IFN- $\alpha$ -2b group 39.8%, with no difference seen between groups, and no significant difference was seen between groups in terms of tolerability.<sup>41</sup> On the other hand, two Italian single-center studies with 441 and 320 patients with IFN-naive genotype 1–4 HCV infection, respectively, found no significant difference between groups in the incidence of adverse events, but reported significantly higher SVR rates in the Peg-IFN- $\alpha$ -2a group than in the Peg-IFN- $\alpha$ -2b group.<sup>42,43</sup> A recent systematic review examining 12 RCT of the efficacy and safety of these two agents found no difference between them in terms of adverse events causing discontinuation. The overall SVR rates based on 8 RCT were 47% for the Peg-IFN- $\alpha$ -2a group and 41% for the Peg-IFN- $\alpha$ -2b group, significantly higher in the former (risk ratio, 1.11; 95% confidence interval [CI], 1.04–1.19;  $P = 0.004$ ).<sup>44</sup> However, a conclusion has not been reached to recommend either agent, due to heterogeneity of the patient populations in HCV genotype, race and Peg-IFN- $\alpha$ -2b dosage in the different RCT, as well as problems with the quality of the RCT in terms of subject numbers and withdrawals, and only limited data concerning adverse events. In Japan, studies have been conducted comparing both agents, but the final results have yet to be published.

Accordingly, at present, Peg-IFN- $\alpha$ -2a and Peg-IFN- $\alpha$ -2b are considered similar from the viewpoints of efficacy and adverse reactions, and there is no definitive evidence supporting a recommendation of either formulation in clinical practice. To improve therapeutic efficacy further, more important considerations will be optimization of the dosage and duration of treatment with other agents, such as ribavirin, for each individual patient, as well as formulation of a treatment plan with consideration of factors that influence therapeutic efficacy for each patient, and control of adverse reactions.

#### Inhibition of HCC by IFN monotherapy

Many reports have emerged from Japan regarding inhibition of hepatocellular carcinogenesis by IFN therapy. Ikeda *et al.*<sup>6</sup> performed a retrospective analysis of cumulative hepatocellular carcinogenesis rates in patients with chronic hepatitis C who underwent IFN monotherapy as initial treatment, stratified for therapeutic

efficacy. The 10-year hepatocellular carcinogenesis rate was 12.0% in the untreated group ( $n = 452$ ), 15.0% in the IFN nonresponsive group, with no SVR and abnormal ALT levels ( $n = 1076$ ) and 1.5% in the SVR group ( $n = 676$ ), significantly lower in the latter. Even in the incomplete response group, with no SVR but normalization of ALT levels ( $n = 298$ ), the 10-year hepatocellular carcinogenesis rate was 2.0%, indicating suppression of HCC.<sup>6</sup> Imai *et al.*<sup>45</sup> and Kasahara *et al.*<sup>7</sup> have reported similar results, with IFN therapy inhibiting hepatocellular carcinogenesis in the normalized ALT group. Furthermore, Yoshida *et al.*<sup>8</sup> conducted a large-scale retrospective study with 2890 patients, reporting that IFN therapy and resultant SVR reduce the risk of developing HCC, including patients in whom ALT levels improved to within two times the upper limit of normal. They further reported that the calculated rate of progression of hepatic fibrosis was  $-0.28/\text{year}$  in IFN responders, indicating amelioration of hepatic fibrosis associated with viral clearance, and even in patients who failed to respond to IFN, the rate of progression of  $-0.2/\text{year}$  indicated inhibition of progression of hepatic fibrosis.<sup>8</sup> Okanoue *et al.* also reported inhibitory effect on development of HCC dependent on the degree of progression of hepatic fibrosis, and amelioration of fibrosis with IFN therapy.<sup>46</sup> Nishiguchi *et al.* conducted a prospective study with patients with HCV-associated cirrhosis, finding HCV eradication or prolonged normalization of ALT levels by IFN therapy significantly reduced the risk of HCC and liver failure.<sup>47</sup>

Overseas, Di Bisceglie *et al.* conducted the Hepatitis C Antiviral Long-term Treatment Against Cirrhosis (HALT-C) trial, a prospective randomized controlled study of whether low-dose Peg-IFN- $\alpha$  maintenance therapy can reduce the rate of liver disease-associated events, including HCC, in non-responders to Peg-IFN- $\alpha$  + ribavirin therapy. They recruited a cohort of 1050 HCV-infected patients with bridging fibrosis or cirrhosis who had not had an SVR to previous therapy with Peg-IFN- $\alpha$  + ribavirin therapy, and randomly allocated them to a group administered Peg-IFN- $\alpha$ -2a 90  $\mu\text{g}/\text{week}$  for 3.5 years or an untreated control group. They compared incidences during the observation period of outcome variables including the following: death, development of HCC, development of hepatic decompensation and exacerbation of histological fibrosis. After 3.8 years of observation in both groups, 157 patients reached one of the end-points, 34.1% of the treatment group and 33.8% of the control group, with no significant difference seen between groups (hazard ratio [HR], 1.01; 95% CI, 0.81–1.27).<sup>48</sup> They also exam-

ined the risk of hepatocellular carcinogenesis in this cohort, with 48 patients (4.8%) developing HCC during the observation period. The 5-year cumulative HCC rate was 5.4% in the treatment group and 5.0% in the control group, with no significant difference seen between groups ( $P = 0.78$ ).<sup>49</sup> The conclusion was that, at this stage, low-dose Peg-IFN- $\alpha$ -2a maintenance therapy does not reduce the rate of liver disease-associated events, including HCC, in non-responders to Peg-IFN- $\alpha$  + ribavirin therapy. Similar results were achieved in a study using Peg IFN- $\alpha$ -2b.<sup>50</sup>

However, Lok *et al.* recently published the results of an extended analysis of the HALT-C cohort. Extending the observation period beyond the previous analysis to a median 6.1 years (greatest, 8.7 years), they reported HCC in 88 patients (8.4%). Including both patients with and without cirrhosis, the 7-year cumulative HCC rate was 7.2% in the treatment group and 9.6% in the control group, with no significant difference seen between groups (HR, 0.77; 95% CI, 0.51–1.18;  $P = 0.24$ ), showing no clear inhibition of hepatocellular carcinogenesis by IFN therapy. If we limit the analysis to patients with cirrhosis, however, the 7-year cumulative HCC rate was 7.8% in the treatment group and 24.2% in the control group, showing a significant reduction in the risk of HCC with low-dose Peg-IFN- $\alpha$ -2a maintenance therapy (HR, 0.45; 95% CI, 0.24–0.83;  $P = 0.01$ ). However, this effect was not significant in patients without cirrhosis, as the 7-year cumulative HCC rate was 8.3% in the treatment group and 6.8% in the control group, actually tending to be higher in the group administered Peg-IFN- $\alpha$  (HR, 1.44; 95% CI, 0.77–2.69;  $P = 0.26$ ).<sup>51</sup>

Inhibition of hepatocellular carcinogenesis by low-dose Peg-IFN- $\alpha$ -2a monotherapy was also examined in Japan in a multicenter collaborative trial. The subjects were 59 patients administered Peg-IFN- $\alpha$ -2a monotherapy and a control group comprising 59 patients matched for age, sex, degree of fibrosis, platelet counts and serum bilirubin levels. They reported a significantly lower cumulative HCC rate in the Peg-IFN- $\alpha$ -2a monotherapy group ( $P = 0.0187$ ) with a relative risk (RR) of 0.167. The reduction in risk of HCC was particularly marked in patients with advanced fibrosis (F3–4) (RR, 0.0847;  $P = 0.0036$ ). Even in patients who failed to eradicate HCV RNA, the HCC rate was significantly lower in those who achieved either an ALT level  $<40 \text{ IU/L}$  or AFP  $<10 \text{ ng/mL}$  at treatment week 24.<sup>19</sup> Improvement in ALT and AFP levels with Peg-IFN- $\alpha$ -2a monotherapy has been reported in other Japanese studies.<sup>52,53</sup>

We can understand that with extension of the observation period, the results of the HALT-C trial confirm that low-dose Peg-IFN- $\alpha$  maintenance therapy reduces the risk of HCC in patients with cirrhosis. The effect was unclear on analysis of the entire cohort in patients without cirrhosis, however, and the results suggest that reduction in the risk of HCC did not emerge until after at least 4 years of low-dose Peg-IFN- $\alpha$  maintenance therapy. On the other hand, the above-mentioned Japanese studies confirmed that IFN therapy significantly reduced the incidence of HCC in patients with sustained normalization of ALT levels, even if SVR was not achieved. In the above-mentioned multicenter collaborative trial of Peg-IFN- $\alpha$ -2a monotherapy, a significant reduction in the HCC was seen, even when patients without cirrhosis were included, and with shorter observation periods. In this way, the results of the HALT-C trial do not agree with Japanese findings. Possible reasons for this discrepancy may include the fact that the average age of the HALT-C cohort was 52 years, younger than the average age of Japanese patients with chronic hepatitis C, and the low overall incidence of HCC. Asahina *et al.* reported that in Japanese patients with chronic hepatitis C, even with the same degree of fibrosis the risk of HCC is considerably higher in older patients, whereas in patients with cirrhosis, there is no significant difference in the risk of HCC associated with aging.<sup>17</sup> We cannot therefore exclude the possibility that differences between Japan and the USA in the ages of patients with chronic hepatitis C and the risk of HCC influenced the results of the HALT-C trial for patients without cirrhosis. Furthermore, there were a considerable number of deaths and liver transplantation events in the HALT-C cohort, the incidences of which were significantly different between patients on low-dose Peg-IFN maintenance therapy and control groups among patients without cirrhosis.<sup>54</sup> These deaths and liver transplantation events give rise to bias in analyses of the risk of HCC. From the above, a certain degree of caution is needed in interpreting the results of the HALT-C trial.

#### Inhibition of HCC by IFN monotherapy in the elderly

As mentioned above, Japanese patients with chronic hepatitis C are older than their Western counterparts, and the risk of developing HCC is higher in elderly patients, even after correction for other risk factors. Although the risk of HCC is significantly reduced with SVR, even in elderly patients, in comparison with younger patients they are more likely to fail to achieve

SVR, and to discontinue treatment due to adverse reactions.<sup>17</sup> With these considerations of therapeutic efficacy and adverse reactions in mind, in Japan, long-term IFN monotherapy is widely used in elderly patients, the aim of treatment being inhibition of hepatocellular carcinogenesis by reducing inflammation rather than viral eradication.

Arase *et al.*<sup>18</sup> examined the reduction in hepatocellular carcinogenesis by IFN therapy in a study with 120 subjects aged  $\geq 60$  years with either chronic hepatitis C or liver cirrhosis. They were treated with natural IFN- $\alpha$  3 MU three times weekly for an average of 2.47 years, and compared with an age- and sex-matched control group not administered IFN comprising 240 subjects. As a result, the 10-year HCC rate was 17.3% in the IFN group and 32.8% in the control group, with an RR of 0.3. AFP levels decreased significantly in the IFN group than in the control group, and the incidence of HCC was particularly low in patients with AFP levels  $< 10$  ng/mL.<sup>18</sup> Nomura *et al.* also conducted a study with 44 patients with genotype 1 HCV infection aged  $\geq 60$  years. They were treated with natural IFN 3 MU three times weekly for 3 years, and compared with a control group not administered IFN, matched for age, sex and hepatic histological findings, comprising 44 subjects. They reported a significantly lower cumulative rate of HCC in the IFN group.<sup>55</sup>

#### Recommendations:

- 1 Eradication of HCV by IFN therapy lowers the risk of HCC.
- 2 Even if HCV cannot be eradicated, we can expect the risk of developing HCC to be reduced through lowering ALT or AFP levels by long-term natural IFN- $\alpha$  therapy or long-term Peg-IFN- $\alpha$ -2a monotherapy.

#### Inhibition of HCC recurrence by IFN therapy

Not only is IFN administered with the aim of inhibiting hepatocellular carcinogenesis in patients with chronic hepatitis C and cirrhosis who have not yet developed HCC, it is also given to patients who have undergone complete ablation or resection of HCC nodules with the aims of preventing recurrence and improving survival rates. Shiratori *et al.*<sup>56</sup> randomly allocated patients who had undergone complete ablation of HCC nodules, using ethanol injection, to a group administered IFN for 48 weeks and an untreated control group, comparing recurrence rates and survival rates. They reported no significant difference between groups in the rate of first recurrence; however, the rates of second and subsequent recurrences were significantly lower in the IFN group, as

were survival rates. These results indicated the usefulness of IFN therapy following complete tumor ablation.<sup>56</sup> Sakaguchi *et al.*<sup>57</sup> and Kudo *et al.*<sup>58</sup> administered low-dose long-term IFN- $\alpha$ -2b or IFN- $\alpha$ -2a therapy to 127 patients with HCC who had undergone complete ablation. Comparison with an untreated control group matched for sex, age and platelet count showed a significant reduction in recurrences after the first recurrence, and a significant improvement in survival rates, the RR for survival being 0.21.<sup>57,58</sup> Another study of IFN + ribavirin therapy following hepatic arterial embolization or radiofrequency ablation reported viral eradication in half of patients, with lower tumor recurrence rates and prolonged survival.<sup>59</sup>

**Recommendation:**

*IFN therapy following complete ablation of HCC can be expected to reduce tumor recurrence rates and improve survival rates.*

**Necessity of follow up of patients who achieved an SVR**

SVR is defined as undetectable levels of serum HCV RNA 24 weeks after the completion of IFN treatment. HCV RNA clearance is usually sustained in cases of SVR, with HCV RNA remaining undetectable in 99–100% over the average 5.6-year observation period (range, 1–8.3 years) in patients with SVR to IFN + ribavirin therapy.<sup>60,61</sup> In studies conducted prior to 2000, however, a somewhat lower proportion at 96–98% of patients remained serum HCV RNA negative.<sup>62–66</sup> Possible causes for this discrepancy are that IFN monotherapy was the mainstay in the earlier studies, and that the sensitivity of testing for HCV RNA was lower at the time, suggesting the possibility of false-positive assessments of SVR.

As described above, achievement of SVR gives sustained clearance of HCV RNA, and significantly reduces the risk of HCC in patients with chronic hepatitis C.<sup>6–8,45,46</sup> However, HCC has been reported to develop during follow up even in patients who have achieved SVR. A number of Japanese studies have addressed hepatocellular carcinogenesis following SVR, with reported HCC rates of 0.9–4.2% over mean observation periods of 3.3–8.0 years. Risk factors for HCC include advanced age, male sex, advanced fibrosis, alcohol consumption, hepatic steatosis and insulin resistance. The interval between achieving SVR and detection of HCC is most often reported as being within 10 years, although some studies reported an interval of greater than 10 years.<sup>8,17,46,67–71</sup> There is a lack of consensus regarding how long patients should be screened for

HCC following SVR, but depending on the risk factors for hepatocellular carcinogenesis in each individual patient, screening for HCC should continue for at least 5–10 years after achieving SVR.

**Recommendation:**

*Risk factors for developing HCC in virological responders include advanced age, male sex, advanced fibrosis, alcohol consumption, hepatic steatosis and insulin resistance. Even following SVR, screening for HCC should continue with consideration of the known risk factors for each individual.*

**3.2 Ribavirin**

Ribavirin, a purine nucleotide analog with a chemical structure resembling guanosine, shows antiviral activity against a wide range of RNA and DNA viruses.<sup>72</sup> Proposed mechanisms for the actions of ribavirin include T-helper cell 1 dominant immune induction, induction of viral mutagenesis, inhibition of RNA polymerase and depletion of intracellular guanosine triphosphate pools.<sup>73</sup> Ribavirin monotherapy for chronic hepatitis C improves ALT levels, but does not decrease HCV RNA or improve liver histology.<sup>74–76</sup> However, IFN- $\alpha$ -2b + ribavirin combination therapy is superior to IFN- $\alpha$ -2b monotherapy in terms of viral clearance and improved ALT levels.<sup>77</sup>

Ribavirin is generally used in combination with one of the Peg-IFN preparations, Peg-IFN- $\alpha$ -2a or Peg-IFN- $\alpha$ -2b. In comparison with Peg-IFN monotherapy, higher end-of-treatment HCV RNA clearance rates are achieved with Peg-IFN + ribavirin combination therapy, but most importantly, the addition of ribavirin markedly decreases the risk of relapse following completion of treatment.<sup>78,79</sup> Presently in Japan, apart from the Peg-IFN preparations, ribavirin can also be used in combination with standard non-pegylated-IFN- $\alpha$ -2a or IFN- $\beta$ . When the pretreatment hemoglobin (Hb) level is  $\geq 14$  g/dL, the daily dose of ribavirin is 600 mg for patients weighing  $\leq 60$  kg, 800 mg for 61–80 kg and 1000 mg for  $>80$  kg.<sup>80,81</sup>

**Therapeutic results**

The efficacy of Peg-IFN + ribavirin combination therapy was confirmed in two Japanese phase III clinical trials.<sup>82,83</sup> In Japanese clinical studies with patients with genotype 1b chronic hepatitis C with high viral loads ( $>100$  kIU/mL), the SVR rate with 48 weeks of Peg-IFN- $\alpha$ -2b + ribavirin therapy was 48% (121/254), and that for 48 weeks of Peg-IFN- $\alpha$ -2a + ribavirin therapy was

59% (57/96).<sup>83,84</sup> In another study, other than with genotype 1b and high viral loads, a high SVR rate of 89% (40/45) was achieved with 24 weeks of Peg-IFN- $\alpha$ -2b + ribavirin therapy.<sup>85</sup>

#### Adverse reactions

Ribavirin is administered p.o. twice daily, after breakfast and dinner. The peak plasma concentration is reached 1–2 h after ingestion, and with repeated administration plasma levels reach equilibrium after 4–8 weeks of treatment. Ribavirin accumulates in the body, remaining in the liver, muscle and within erythrocytes for long periods. Ribavirin is mostly eliminated by the renal route, and caution is required when prescribing to patients with renal disease or impaired renal function. It is contraindicated in patients with a creatinine clearance  $\leq 50$  mL/min. Ribavirin is not eliminated by dialysis, so it is generally contraindicated in patients with renal failure on dialysis.

The main adverse reaction to ribavirin is hemolytic anemia, so caution is required when considering ribavirin therapy in patients with anemia or heart conditions (e.g. ischemic heart disease, heart failure, arrhythmia). In a Japanese clinical trial of Peg-IFN- $\alpha$ -2b + ribavirin combination therapy, treatment was discontinued in 8–11% of patients, and the ribavirin dose reduced in 20%, due to anemia. Dose reduction was more common in patients with a pretreatment Hb  $< 14$  g/dL, neutrophil count  $< 2000/\mu\text{L}$  or platelet count  $< 120\,000/\mu\text{L}$ , and in females. In particular, a reduction in the dose of Peg-IFN or ribavirin was required in 80% of patients aged  $\geq 65$  years with a pretreatment Hb  $\leq 13$  g/dL. The rate of discontinuation of treatment was high in patients with a decline in Hb  $\geq 2$  g/dL at 2 weeks from the start of treatment, so the authors suggest reducing the ribavirin dose by 200 mg/day at this point.<sup>86</sup> The criteria for ribavirin dose reduction or discontinuation when a decline in Hb occurs during treatment (in patients without heart conditions) are: reduce the daily dose by 200 mg (400 mg if started at 1000 mg) for Hb  $< 10$  g/dL, and discontinue if Hb is  $< 8.5$  g/dL.<sup>80,81</sup> In one of the above-mentioned Japanese clinical studies, the SVR rate was 62.5% when no reduction in the IFN or ribavirin dose was needed, 45.7–53.3% when a dose reduction or temporary withdrawal was needed, falling to 19.2% when treatment was discontinued.<sup>83</sup> Accordingly, to achieve SVR it is important to control any decline in Hb appropriately, complete the treatment without discontinuation and as much as possible avoid any dose reductions or temporary withdrawals.

It has become evident that two functional variants in the inosine triphosphatase (*ITPA*) gene on chromosome 20 (rs7270101 and rs1127354) are associated with severe anemia during Peg-IFN + ribavirin therapy.<sup>87,88</sup> Of the *ITPA* polymorphism (rs1127354), the CC genotype (major-homo) was strongly associated with treatment-induced anemia in comparison with the CA + AA genotypes, and the CC genotype was an independent risk factor for ribavirin dose reduction.<sup>89</sup> Accordingly, patients with the CC genotype and low Hb need to be monitored for further decline in Hb during treatment.

Other adverse reactions associated with ribavirin include lymphopenia, hyperuricaemia, pruritus, rashes, cough and nasal congestion. Teratogenicity has been reported in animal studies with ribavirin, so it is contraindicated in pregnant women, women who may be pregnant and breastfeeding women. Transfer into the seminal fluid cannot be ruled out, so when ribavirin is administered to women who might become pregnant, or men whose partner might become pregnant, they should be advised to use contraception during treatment and for 6 months after its completion.

#### Recommendations:

- 1 In comparison with Peg-IFN monotherapy, HCV RNA is more likely to be undetectable at the end of treatment with Peg-IFN + ribavirin combination therapy, and the risk of relapse following completion of treatment is markedly decreased.
- 2 The main adverse reaction to ribavirin is hemolytic anemia, so caution is required when considering ribavirin therapy in patients with anemia or heart conditions.
- 3 To achieve SVR it is important to control any decline in Hb appropriately, complete the treatment without discontinuation, and as much as possible avoid any dose reductions or temporary withdrawals.
- 4 SNPs (rs7270101 and rs1127354) in the *ITPA* gene are associated with severe anemia during Peg-IFN + ribavirin therapy.
- 5 Due to concerns regarding teratogenicity, ribavirin is contraindicated in pregnant and breastfeeding women. Women who might become pregnant, and men whose partner might become pregnant, should be advised to use contraception.

### 3.3 Telaprevir

Telaprevir, discovered through optimization of  $\alpha$ -ketoamide scaffolds, is an antiviral agent that can be administered p.o.<sup>90</sup> A protease inhibitor, telaprevir

directly inhibits NS3-4A serine protease, a HCV gene non-structural protein that plays an important role in HCV replication, thereby strongly inhibiting viral replication.<sup>91</sup> Telaprevir inhibits replication of the HCV genotype 1 particularly strongly, and was approved in September 2011 for use in Japan in combination with Peg-IFN and ribavirin in the treatment of genotype 1 chronic hepatitis C with a high viral load ( $\geq 5.0$  log IU/mL).

### Therapeutic results

**Treatment-naïve patients.** The duration of telaprevir + Peg-IFN- $\alpha$ -2b + ribavirin triple therapy is 24 weeks, with all three agents for the first 12 weeks, then Peg-IFN- $\alpha$ -2b + ribavirin dual therapy for the remaining 12 weeks. In a Japanese phase III clinical trial of 24 weeks of triple therapy for IFN-naïve patients (aged  $\leq 65$  years), the SVR was 73% (92/126), significantly higher than that of 49% (31/63) for the control group, given Peg-IFN- $\alpha$ -2b + ribavirin dual therapy for 48 weeks (Table 1). The relapse rate was 17% (21/126), the breakthrough rate 3% (4/126) and the non-response rate 1% (1/126). No correlation was seen between sex or viral load at commencement and SVR, whereas the SVR rate was higher in patients aged  $< 50$  years than in those aged  $\geq 50$  years (85% vs 67%,  $P = 0.034$ ).<sup>11</sup>

Analysis of therapeutic efficacy according to adherence showed that the SVR rate in patients who discontinued none of the three agents was 84% (66/79), 60% (12/20) in those who discontinued telaprevir alone and 52% (14/27) in those who discontinued all three agents. The SVR rate was high at 79% (85/108) in patients with  $\geq 60\%$  adherence to telaprevir and 39% (7/18) in those with  $< 60\%$  adherence. Similarly, the SVR rate was high at 84% (68/81) in patients with  $\geq 80\%$

adherence to Peg-IFN- $\alpha$ -2b, and was less than 60% in those with  $< 80\%$  adherence. The SVR rate was high at 93% (13/14) in patients with  $\geq 80\%$  adherence to ribavirin, and although the SVR rate decreased as adherence declined, it was still 53% (8/15) in those with  $< 20\%$  adherence to ribavirin.<sup>11</sup>

In terms of virological kinetics, the SVR rate was 75% (81/108) in patients achieving a rapid virological response (RVR) (Table 2) and 61% (11/18) in those failing to achieve an RVR. The SVR rate was 80% (70/88) in patients achieving an extended RVR (eRVR) and 58% (22/38) in those failing to achieve an eRVR (Table 3).<sup>11</sup>

**Relapsers and non-responders to previous treatment.** A Japanese trial of 24 weeks' triple therapy for relapsers and non-responders to previous treatment yielded SVR rates of 88% (96/109) and 34% (11/32), respectively (Table 4). No correlation was seen between sex, age or viral load at commencement and SVR. Analysis of therapeutic efficacy according to adherence showed that the SVR rate was 91% (93/102) in relapsers with  $\geq 40\%$  adherence to telaprevir and 43% (3/7) in those with  $< 40\%$  adherence. In non-responders to previous treatment, the SVR rate was 40% (10/25) with  $\geq 80\%$  adherence to telaprevir and 17% (1/6) in those with 60–80% adherence. The SVR rate was  $\geq 80\%$  in relapsers to previous treatment with  $\geq 40\%$  adherence to Peg-IFN- $\alpha$ -2b and 48% (11/23) in non-responders to previous treatment only with  $\geq 80\%$  adherence. The SVR rate was high at  $\geq 85\%$  in relapsers with  $\geq 20\%$  adherence to ribavirin and 33–38% in non-responders even with 40–80% adherence to ribavirin.<sup>9</sup>

In terms of virological kinetics, among relapsers the SVR rate was 92% (90/98) in those achieving an RVR and 55% (6/11) in those failing to achieve an RVR. For non-responders to previous treatment, the SVR rate was 39% (9/23) in those achieving an RVR and 22% (2/9) in those failing to achieve an RVR. The SVR rate was 96% (84/88) in relapsers achieving an eRVR and 57% (12/21) in those failing to achieve an eRVR; whereas for non-responders to previous treatment the SVR rate was 47% (9/19) in those achieving an eRVR and 15% (2/13) in those failing to achieve an eRVR (Table 3).

### Recommendations:

- 1 The SVR rate was 73% in IFN-naïve patients administered telaprevir + Peg-IFN- $\alpha$ -2b + ribavirin triple therapy for 24 weeks, significantly higher than that of 49% in the control group administered Peg-IFN- $\alpha$ -2b + ribavirin dual therapy for 48 weeks.

**Table 1** Therapeutic results for telaprevir + Peg-IFN- $\alpha$ -2b + ribavirin triple therapy in treatment-naïve patients (SVR rate, %) (reproduced from<sup>11</sup>).

	Telaprevir + Peg-IFN- $\alpha$ -2b + ribavirin triple therapy	Peg-IFN- $\alpha$ -2b + ribavirin dual therapy	<i>P</i>
SVR	73.0	49.2	0.002
Relapse	16.7	22.2	
Breakthrough	3.2	1.6	
Non-response	0.8	20.6	$< 0.0001$

Peg-IFN, pegylated interferon; SVR, sustained viral response.

2 Telaprevir + Peg-IFN- $\alpha$ -2b + ribavirin triple therapy achieved SVR rates in relapsers and non-responders to previous treatment of 88% and 34%, respectively.

Table 2 Virological response definitions

Virological response	Definition
Rapid virological response (RVR)	Serum hepatitis C virus (HCV) RNA undetectable at treatment week 4
Extended RVR (eRVR)	Serum HCV RNA undetectable at both treatment week 4 and 12
Early virological response (EVR)	cEVR or pEVR
Complete EVR (cEVR)	Serum HCV RNA undetectable at treatment week 12
Partial EVR (pEVR)	Serum HCV RNA detectable at treatment week 12 but decrease $\geq 2 \log_{10}$ IU/mL
End of treatment response (ETR)	Serum HCV RNA undetectable at the end of treatment
Sustained virological response (SVR)	Serum HCV RNA undetectable 24 weeks after the completion of treatment
Breakthrough	Reappearance of HCV RNA at any time during treatment having once been undetectable
Relapse	Reappearance of HCV RNA following treatment having been undetectable during treatment
Non-responder	Serum HCV RNA never undetectable during treatment
Null responder	Serum HCV RNA decrease $< 2 \log_{10}$ IU/mL at treatment week 12
Partial responder	Greater than $2 \log_{10}$ IU/mL decrease in serum HCV RNA level from baseline at treatment week 12, but serum HCV RNA detectable at treatment week 24

N.B.: The 2009 American Association for the Study of Liver Diseases (AASLD) "Diagnosis, management, and treatment of hepatitis C: an update" define non-responder, null responder and partial responder as "failure to clear HCV RNA from serum after 24 weeks of therapy", "failure to decrease HCV RNA by  $< 2$  logs after 24 week of therapy" and " $2 \log$  decrease in HCV RNA but still HCV RNA positive at week 24", respectively.<sup>116</sup> However, the 2011 version, updated to include telaprevir and boceprevir, dropped the non-responder category, and redefined null responder and partial responder as "failure to decrease HCV RNA level by at least  $2 \log$  IU/mL at treatment week 12" and "decrease in HCV RNA level by at least  $2 \log$  IU/mL at treatment week 12 but HCV RNA still detected at treatment week 24", respectively.<sup>101</sup> In these guidelines, we define null and partial responder as per the 2011 AASLD guidelines, and further define non-responder as encompassing both null and partial responders.

## Adverse reactions

The incidence of adverse reactions is greater for telaprevir + Peg-IFN- $\alpha$ -2b + ribavirin triple therapy than for Peg-IFN + ribavirin dual therapy. The most important adverse reactions are skin disorders and anemia.

In one study, skin disorders were reported in 85% (226/267) of patients, of greater severity than with dual therapy. The timing of onset was within 7 days after commencement of treatment in 56% (150/267) and within 28 days in 77% (205/267). More than 50% of the body surface was affected in 5% (19/355) of patients. Constitutional symptoms such as fever and lymphadenopathy were reported in 7% of patients, and serious skin disorders, including Stevens–Johnson syndrome, drug-induced hypersensitivity syndrome and erythema multiforme with mucosal involvement, in 1.5% (4/267).<sup>92</sup> Accordingly, strict attention should be given to any skin changes. A dermatologist should be consulted in the management of any treatment-induced skin disorders, and appropriate treatment promptly commenced in accordance with the symptom severity, topical corticosteroids and oral anti-allergic drugs for milder cases, and systemic corticosteroids for more severe cases. Most cases can be managed with topical corticosteroids and oral anti-allergic drugs. However, when skin disorders occur the hepatologist should not treat them his/herself, but should always consult a dermatologist colleague, even for mild symptoms, and follow their instructions regarding the possibility of exacerbation, and the use of topical and systemic medication to control symptoms. Subsequent collaboration is also important. The decision whether telaprevir therapy can be continued should also be made in consultation with the dermatologist, with due consideration of therapeutic efficacy and adverse reactions.

Anemia is an important adverse reaction to Peg-IFN- $\alpha$ -2b + ribavirin dual therapy, with a strong correlation between the SNP (rs1127354) of the ITPA gene and a decline in Hb during treatment.<sup>87,88,93</sup> The addition of telaprevir to dual therapy causes even more severe anemia. In the above-mentioned Japanese clinical trial for treatment-naïve patients, the incidence of grade 1 anemia (Hb 9.5–11.0 g/dL) was 39.7% in the group administered telaprevir + Peg-IFN + ribavirin triple therapy and 50.8% in the group on Peg-IFN + ribavirin dual therapy, whereas the incidence of grade 2 anemia (Hb 8.0–9.5 g/dL) was 27.0% and 17.5%, respectively, and grade 3 anemia (Hb  $< 8.0$  g/dL) occurred only in the triple therapy group.<sup>11</sup> The rate of treatment discontinuation due to anemia is also high with triple therapy.



**Table 3** Therapeutic results for telaprevir + Peg-IFN- $\alpha$ -2b + ribavirin triple therapy stratified by RVR and eRVR (SVR rate, %) (reproduced from <sup>9,11</sup>)

	RVR		eRVR	
	Achieved	Not achieved	Achieved	Not achieved
Initial treatment	75% (81/108)	61% (11/18)	80% (70/88)	58% (22/38)
Relapse	92% (90/98)	55% (6/11)	96% (84/88)	57% (12/21)
Non-response	39% (9/23)	22% (2/9)	47% (9/19)	15% (2/13)

eRVR, extended rapid viral response; RVR, rapid viral response; SVR, sustained viral response.

Similarly to dual therapy, with triple therapy including telaprevir, significantly greater decreases in Hb early in the treatment period are seen with the CC genotype of the ITPA gene than with the CA/AA genotypes. Rapid decreases in Hb are seen up to treatment week 4 in patients with the CC genotype.<sup>94</sup> Risk factors for a Hb level <11.0 g/dL at treatment week 4 were female sex, body mass index <23, CC genotype of the ITPA gene and age  $\geq$ 50 years. Risk factors for a Hb level <8.5 g/dL, one of the discontinuation criteria, were patients weighing <60 kg and aged  $\geq$ 61 years. Patients with any of these risk factors should be carefully monitored for changes in Hb levels.

The response to a decline in Hb should be regular Hb measurements and an early reduction in the ribavirin dose. As mentioned above, in Japanese clinical trials of initial therapy and retreatment, reductions in the ribavirin dose had relatively little effect on therapeutic efficacy.<sup>9,11</sup> In particular, SVR rates  $\geq$ 85% were achieved in relapsers as long as at least 20% of the intended ribavirin dose was administered.<sup>9</sup>

Some other noteworthy adverse reactions seen in the early treatment period that have come to light through post-marketing surveillance are raised serum creatinine (renal dysfunction) and hyperuricaemia. As these generally appear within the first week of treatment, patients should be monitored for rises in serum creatinine and

uric acid soon after treatment commences. Japanese clinical trials of triple therapy including telaprevir did not include patients with cirrhosis, so its safety in these patients has not been established. Clinicians should be aware that triple therapy is not approved for patients with cirrhosis under the national medical insurance scheme.

#### Recommendations:

- 1 Serious skin disorders can occur with telaprevir + Peg-IFN + ribavirin triple therapy. When skin disorders occur, the hepatologist should not treat them himself, but should always consult a dermatologist colleague, even for mild symptoms, and follow their instructions regarding the possibility of exacerbation, and the use of topical and systemic medication to control symptoms. The decision whether telaprevir therapy can be continued should also be made in consultation with the dermatologist, with due consideration of therapeutic efficacy and adverse reactions.
- 2 A decline in Hb should be managed with regular Hb measurements and an early reduction in the ribavirin dose.
- 3 Serum creatinine and uric acid levels may rise early in the treatment period.
- 4 In patients with liver cirrhosis, the safety of triple therapy including telaprevir has not been established, and thus triple therapy is not approved for cirrhosis by national medical insurance in Japan.

**Table 4** Therapeutic results for telaprevir + Peg-IFN- $\alpha$ -2b + ribavirin triple therapy in relapsers and non-responders to previous treatment (SVR rate, %) (reproduced from <sup>9</sup>)

	Relapsers	Non-responders to previous treatment
SVR	88.1	34.4
Relapse	7.3	40.6
Breakthrough	0.9	18.8
Non-response	0.9	6.3

SVR, sustained viral response.

#### Drug interactions

Telaprevir strongly inhibits the CYP3A4/5 drug metabolizing enzyme, and may increase plasma levels of co-administered drugs that are also substrates of CYP3A4/5. Telaprevir is also metabolized by CYP3A4, so co-administration with inducers of CYP3A4 may lower plasma telaprevir levels. As a result, co-administration of a number of agents with telaprevir is contraindicated (Table 5) and caution is advised with

Table 5 Drugs contraindicated for co-administration with telaprevir with trade names (reproduced from <sup>95</sup>)

Contraindicated drug (generic name)	Trade names
Quinidine sulfate hydrate	Quinidine sulfate
Bepridil hydrochloride hydrate	Vascor, Bepricor
Flecainide acetate	Tambocor
Propafenone hydrochloride	Rythmol, Pronon
Amiodarone hydrochloride	Cordarone, Ancaron
Pimozide	Orap
Ergotamine tartrate	Cafergot, Ergomar
Dihydroergotamine mesilate	Migranal, Dihydergot
Ergometrine maleate	Oxytocin
Methylergometrine maleate	Methergine, Utergin
Triazolam	Halcion, Hypam, Trilam
Lovastatin/simvastatin	Crestor/Zocor
Atorvastatin calcium hydrate	Lipitor, Caduet
Alfuzosin	Uroxatral
Vardenafil hydrochloride hydrate	Levitra
Sildenafil citrate (for treatment of pulmonary hypertension)	Viagra, Revatio
Tadalafil (for treatment of pulmonary hypertension)	Cialis, Adcirca
Blonanserin	Lonasen
Coldicine (when administered to patients with liver or kidney disease)	Colgout, Lengout
Rifampicin	Aptecin, Rifadin, Rimactane

many others.<sup>95</sup> The package insert should be referred to before administrating telaprevir.

**Recommendation:**

*Telaprevir strongly inhibits the CYP3A4/5 drug metabolizing enzyme and is also a substrate, so co-administration of a number of agents is contraindicated or requires caution. The package insert should be referred to before administrating telaprevir.*

**Drug resistance**

Telaprevir-resistant mutations (V36, T54, R155, A156, V170) have been reported in cases of viral breakthrough with telaprevir monotherapy,<sup>96–98</sup> as well as in cases on virological non-response and relapse with triple therapy.<sup>99,100</sup> The reported incidences of telaprevir resistance are 12% with initial therapy and 22% with retreatment. One study found telaprevir-resistant viruses in 80–90% of cases of viral breakthrough, virological non-response and relapse.<sup>101</sup> Resistance is more common in

genotype 1a than genotype 1b HCV. In most cases, these telaprevir-resistant viruses become undetectable, reverting to wild type, over time.<sup>97,98</sup>

**3.4 Initial treatment—Genotype 1 with high viral load**

A number of new agents are under development for the treatment of HCV genotype 1 with a high viral load ( $\geq 5.0 \log_{10}$  IU/mL using real-time PCR, HCV core antigen  $\geq 300$  fmol/L), which is often refractory to treatment. These include HCV-selective antiviral agents in the form of enzyme inhibitors (protease inhibitors, polymerase inhibitors, NS5A inhibitors), new IFN formulations, ribavirin prodrugs and immunopotential agents. At present, however, the only therapies available for clinical use in Japan are antiviral combinations based on an IFN formulation, in other words Peg IFN (IFN)  $\pm$  ribavirin  $\pm$  telaprevir. Peg-IFN + ribavirin therapy was approved available for use in Japan in 2004, improving therapeutic efficacy but with the addition of adverse reactions such as anemia. Subsequent detailed studies in a large number of IFN-treated subjects have identified correlations between viral, host and drug factors on the one hand and therapeutic effect and adverse reactions on the other hand. At present, we are moving away from uniform therapies in accordance with HCV genotype and viral load towards optimizing therapy for each individual patient, with the emphasis on response-guided therapy that adjusts the duration of treatment according to the response. In 2009, IFN- $\beta$  + ribavirin therapy, which has a relatively good safety profile with fewer adverse reactions such as depression, gained approval under the national medical insurance scheme in Japan.

In 2011, telaprevir + Peg-IFN + ribavirin triple therapy became available for use in Japan. The addition of telaprevir to Peg-IFN + ribavirin improves the therapeutic efficacy, also shortening the treatment duration from 48 (or 72) weeks to 24 weeks, but with the addition of adverse reactions such as severe anemia and serious skin disorders. Japanese clinical trials of this triple therapy were conducted with patients aged  $\leq 65$  years with platelet counts  $\geq 100\,000/\mu\text{L}$ , so we need to gather scientific evidence regarding therapeutic efficacy and adverse reactions in patients at high risk of developing HCC, including elderly patients and those with advanced hepatic fibrosis.

Recently interleukin (IL)-28B SNP and substitutions of amino acids in the HCV core and NS5A regions are widely recognized as important pretreatment predictors of therapeutic efficacy. Accordingly, although not

approved by national medical insurance, if possible, IL-28B SNP and substitutions of amino acids in the HCV core and NS5A regions should be tested pre-treatment, and antiviral therapy selected based on the results. These tests can be referred to outside laboratories.

#### **Peg-IFN + ribavirin combination therapy**

*Prediction of therapeutic efficacy using pretreatment factors.* Factors that predict therapeutic efficacy prior to commencement of Peg-IFN + ribavirin combination therapy can be divided into host and viral factors. Of the host factors, testing for IL-28B SNP is useful. Patient groups with a minor allele G at rs8099917 (TG/GG) show greater resistance to Peg-IFN + ribavirin therapy than those with a major allele (TT).<sup>102–104</sup> Other predictors of antiviral efficacy are age and degree of fibrosis.<sup>105</sup> SVR rates are relatively high in non-elderly and non-advanced fibrosis patients, and generally low in elderly patients and those with advanced fibrosis. Even among the elderly, SVR rates are known to be particularly low in elderly female patients.<sup>106,107</sup>

Of the viral factors, amino acid 70 and 91 substitutions in the HCV core region,<sup>108,109</sup> and amino acid substitutions in the HCV NS5A region (interferon sensitivity-determining region [ISDR]),<sup>110–112</sup> are independent predictive factors for the therapeutic efficacy of Peg-IFN + ribavirin therapy. Therapeutic efficacy is high in patients with wild-type at amino acid 70 in the HCV core region and increases with the number of amino acid substitutions in the HCV NS5A region. Amino acid substitutions outside the HCV NS5A ISDR (IFN/ribavirin-resistance determining region; IRRDR) are also known to affect the therapeutic efficacy of this regimen.<sup>113</sup>

#### *Recommendations:*

- 1 *Prior to commencement of Peg-IFN + ribavirin combination therapy, host factors that predict antiviral efficacy are IL-28B SNP, age and degree of fibrosis. Of the viral factors, amino acid 70 and 91 substitutions in the HCV core region and amino acid substitutions in the HCV NS5A region are independent predictive factors for the therapeutic efficacy of Peg-IFN + ribavirin therapy.*
- 2 *If possible, IL-28B SNP and amino acid substitutions in the HCV core and NS5A regions should be tested to enable accurate prediction of the therapeutic efficacy. These tests can be referred to outside laboratories, but are not approved by national medical insurance.*

*Prediction of therapeutic efficacy using response to treatment: Response-guided therapy and treatment discontinuation criteria.* The response to treatment by each individual patient after commencing Peg-IFN + ribavirin combination therapy, in other words HCV RNA dynamics, is a good marker for predicting SVR.<sup>114</sup> The risk of resistant viral mutations is low with Peg-IFN + ribavirin therapy, so it is possible, as well as useful, to commence treatment and then formulate a treatment plan based on the early response to therapy (response-guided therapy). As the physical and financial burdens on patients of Peg-IFN + ribavirin therapy are great, when the decrease in the HCV RNA load is very poor and SVR cannot be anticipated, in line with the treatment discontinuation criteria, it is recommended that antiviral therapy with the aim of achieving SVR should be discontinued.

In two Japanese clinical trials of 24 weeks' Peg-IFN + ribavirin combination therapy, HCV RNA was measured using the Amplicor PCR method (Roche Molecular Systems, Pleasanton, CA, USA). The SVR rate was  $\geq 70\%$  when HCV RNA became undetectable before treatment week 12, lower when HCV RNA became undetectable after treatment week 12 and SVR did not occur when HCV RNA was still detectable at treatment week 24.<sup>82,83</sup> An overseas study also reported that, in particular, the early viral response (EVR) at treatment week 12 (Table 2), either complete EVR (undetectable HCV RNA) or partial EVR ( $\geq 2$  log IU/mL decrease in HCV RNA), was significantly associated with SVR.<sup>115</sup> Based on this result, the American Association for the Study of Liver Diseases (AASLD) guidelines recommend that when Peg-IFN + ribavirin combination therapy (48 weeks) fails to reduce HCV RNA  $\geq 2$  log IU/mL at treatment week 12 in patients with genotype 1, or if HCV RNA remains positive at week 24, treatment should be discontinued.<sup>116</sup>

For patients in whom HCV RNA becomes undetectable between treatment weeks 13 and 24, it has become evident that increasing the treatment period to 72 weeks improves SVR rates.<sup>117–120</sup> Real-time PCR testing has also shown that SVR can be achieved in the group in whom HCV RNA becomes undetectable between treatment weeks 25 and 36; therefore, in Japan, extension of the treatment period to 72 weeks is recommended in patients in whom HCV RNA becomes undetectable between treatment weeks 13 and 36. Extended treatment periods have been reported to be particularly useful in patient groups with amino acid 70 and 91 substitutions in the HCV core region and wild-type at ISDR in the HCV NS5A region.<sup>121</sup> In patients with advanced hepatic fibrosis or elderly patients in whom

HCV RNA becomes undetectable between treatment weeks 9 and 12; relapse rates are high if treatment is stopped at treatment week 48. Accordingly, extending the treatment period to 72 weeks is an option worth considering, although it is not approved by national medical insurance.<sup>122</sup>

In recent years, real-time PCR testing has enabled measurement of HCV RNA over a wide range of viral loads. This suggests the possibility of assessing each individual patient's response to treatment through the rate of decrease in HCV RNA earlier than treatment week 12. In other words, analysis of SVR rates in patients administered response-guided Peg-IFN + ribavirin combination therapy stratified according to the rate of decrease in HCV RNA at treatment week 4 yielded SVR rates of 4%, 18%, 55%, 66% and 89%, respectively, for HCV RNA decreases <1 log, 1–2 log, 2–3 log, 3–4 log and  $\geq 4$  log (but still detectable), and 100% for undetectable HCV RNA. A strong correlation was seen between the rate of HCV decrease at treatment week 4 and SVR ( $P < 0.001$ ) (Table 6).<sup>114</sup> On the other hand, HCV RNA did not become undetectable in patients on the same therapy with an HCV decrease <1 log at treatment week 8, or <2 log at treatment week 12, so at least discontinuation of treatment aimed at achieving SVR is recommended for these patient groups at week 8 or 12.

In patients at high risk of hepatocellular carcinogenesis, such as the elderly and those with advanced fibrosis, consideration should be given to continuing Peg-IFN + ribavirin combination therapy, aiming for biochemical improvement rather than SVR. In a Japanese trial, in relapsers and non-responders in whom viral clearance could not be achieved, the ALT normalization rates 6 months after completion of treatment were 56% (5/9) and 62% (8/13), respectively. Among patients with normalized ALT levels 6 months after treatment, long-term biochemical response persisting until 2 years post-treatment was achieved in all but one patient with normalized ALT levels.<sup>123</sup> Accordingly, in patients at high risk of HCC, if normalization of AST/ALT levels has been achieved at treatment week 36 with combination therapy, even if HCV RNA remains

detectable, it is worthwhile continuing treatment to 48 weeks in total.<sup>122</sup>

#### Recommendations:

- 1 After commencement of Peg-IFN + ribavirin combination therapy, the timing of HCV RNA clearance and the rate of decrease in HCV RNA over time are useful markers of therapeutic efficacy.
- 2 The rate of decrease in HCV RNA at treatment week 4 is a good marker of SVR.
- 3 Extension of the treatment period to 72 weeks is recommended in patients in whom HCV RNA becomes undetectable between treatment weeks 13 and 36. In patients with advanced hepatic fibrosis or elderly patients in whom HCV RNA becomes undetectable between treatment weeks 9 and 12, relapse rates are high if treatment is stopped at treatment week 48. Accordingly, extending the treatment period to 72 weeks is an option worth considering, although it is not approved by national medical insurance.
- 4 Discontinuation of treatment should be considered in patients with a HCV decrease <1 log at treatment week 8 or <2 log at treatment week 12, and treatment should be discontinued if HCV clearance is not achieved before treatment week 36 even with an HCV RNA decrease  $\geq 2$  log at treatment week 12.
- 5 In patients at high risk of HCC, if normalization of AST/ALT levels has been achieved at treatment week 36 with combination therapy, even if the discontinuation criteria are met, continuing treatment to 48 weeks in total should be considered.

*Adherence and therapeutic efficacy.* Overseas, clinical trials have confirmed the influence of adherence to Peg-IFN + ribavirin combination therapy on therapeutic effect.<sup>115,124–127</sup> In another study, SVR rates were significantly higher in patients who took  $\geq 80\%$  of the intended dose of both Peg-IFN and ribavirin than in other patients (51% vs 34%). The influence of dose reductions on therapeutic effect was most marked in patients with dose reductions before treatment week 12.<sup>24</sup> In one Japanese study, a significant correlation was found between the EVR rate and the Peg-IFN dose at treatment week 12, but not the ribavirin dose. With Peg-IFN- $\alpha$ -2b doses

Table 6 The decline of serum HCV-RNA at treatment week 4 and SVR rates with response-guided therapy in patients with Genotype 1/high viral load. HCV RNA decline vs. SVR,  $P < 0.001$

HCV RNA decrease (log)	<1 log	1–2 log	2–3 log	3–4 log	$\geq 4$ log	Undetectable HCV
SVR rate	4% (2/53)	18% (10/55)	55% (48/87)	66% (58/88)	89% (70/79)	100% (29/29)

HCV, hepatitis C virus; SVR, sustained viral response.

<1.2 µg/kg per week, EVR rates decreased in a dose-dependent manner.<sup>128</sup> The relapse rate following viral clearance was 13% in the group administered ribavirin ≥10 mg/kg per day (and only 3% for ≥12 mg/kg per day), and higher at 50% in those administered <6 mg/kg per day, with a dose-dependent relationship between ribavirin dose and the relapse rate.<sup>129</sup>

*Recommendations:*

- 1 In patients administered Peg-IFN + ribavirin combination therapy, a correlation is seen between the Peg-IFN dose and the EVR rate. With Peg-IFN-α-2a, ≥80% adherence is desirable, and with Peg-IFN-α-2b, a starting dose ≥1.2 µg/kg per week.
- 2 A correlation is seen between the ribavirin dose and the relapse rate. Administration of ≥80% of the scheduled dose, or completion of treatment at a maintenance dose ≥10 mg/kg per day (if possible, ≥12 mg/kg per day), will decrease the risk of relapse following the end of therapy.

**Telaprevir + Peg-IFN + ribavirin combination therapy**

In a Japanese clinical trial, the SVR rate for telaprevir + Peg-IFN + ribavirin triple therapy in IFN-naïve patients was 73% (92/126).<sup>9</sup> Compared to the above-mentioned Peg-IFN + ribavirin combination therapy, higher SVR rates are achieved with telaprevir + Peg-IFN + ribavirin triple therapy with a short treatment duration of 24 weeks, indicating superior therapeutic efficacy. Accordingly, if it is tolerated, telaprevir + Peg-IFN + ribavirin triple therapy is the treatment of first choice for IFN-naïve patients.

An investigation of factors affecting the therapeutic efficacy of telaprevir + Peg-IFN-α-2b + ribavirin triple therapy found that individualization of treatment according to IL-28B SNP and amino acid 70 substitutions in the HCV core region is extremely useful.<sup>130</sup> A high SVR rate of 83.8% was achieved in patients with the IL-28B (rs8099917 SNP) TT major allele, but only 27.6% with the TG or GG minor alleles. Furthermore, the SVR rate was 50% in patients with IL-28B SNP minor alleles and wild-type amino acid 70 in the HCV core region, but only 11.8% in those with substitutions at amino acid 70. Protease inhibitor-resistant mutations are seen in more than half of patients who fail to achieve SVR with telaprevir + Peg-IFN-α-2b + ribavirin triple therapy. Cross-resistance to protease inhibitors has also been identified, and the AASLD guidelines recommend against retreatment with protease inhibitors.<sup>101</sup>

From the above, for patients scheduled for telaprevir + Peg-IFN-α-2b + ribavirin triple therapy,

although not approved by national medical insurance, testing for IL-28B SNP and amino acid substitutions in the HCV core region should be performed to enable selection of the optimum therapy regimen based on accurate predictions of therapeutic efficacy. As a general rule, telaprevir + Peg-IFN-α-2b + ribavirin triple therapy is not recommended in patients with IL-28B SNP minor alleles (TG or GG) and amino acid 70 substitutions in the HCV core region.

When telaprevir + Peg-IFN + ribavirin triple therapy fails to reduce the HCV RNA to ≤3 log copy/mL at treatment week 4, HCV RNA fails to become undetectable by treatment week 12 or HCV RNA rises ≥2 log copy/mL during therapy, there may have been pre-existing resistant virus present.<sup>131</sup> In these cases, there is a risk that continued treatment may confer resistance to second generation protease inhibitors, so the treatment should be discontinued.

There have been several clinical trials of telaprevir + Peg-IFN + ribavirin triple therapy (ADVANCE study,<sup>99</sup> ILLUMINATE study<sup>132</sup>). The AASLD guidelines, based on their results indicating eRVR is a good predictor of therapeutic efficacy, recommend response-guided therapy, with 24 weeks' triple therapy in patients who achieve eRVR, and a further 24 weeks of Peg-IFN + ribavirin dual therapy, to a total of 48 weeks in patients who do not achieve eRVR. They also recommend an extended period of 48 weeks' telaprevir + Peg-IFN + ribavirin triple therapy, i.e. for 12 weeks of telaprevir + Peg-IFN + ribavirin triple therapy followed by an additional 36 weeks of Peg-IFN + ribavirin dual therapy for null responders to Peg-IFN + ribavirin dual therapy (HCV RNA decrease, <2 log).<sup>10</sup> However, in Japan, 48 weeks' extended telaprevir + Peg-IFN + ribavirin triple therapy is not approved by national medical insurance.

*Recommendations:*

- 1 If it is tolerated, telaprevir + Peg-IFN + ribavirin triple therapy is the treatment of first choice at present for IFN-naïve patients.
- 2 Individualization of telaprevir + Peg-IFN-α-2b + ribavirin triple therapy according to IL-28B SNPs and amino acid 70 substitutions in the HCV core region is extremely useful. Although not approved by national medical insurance in Japan, both tests should be performed to enable selection of the optimum therapy regimen. As a general rule, telaprevir + Peg-IFN-α-2b + ribavirin triple therapy is not recommended in patients with IL-28B minor alleles and amino acid 70 substitutions in the HCV core region.

- 3 Further studies are required of the therapeutic efficacy and adverse reactions with telaprevir + Peg-IFN- $\alpha$ -2b + ribavirin triple therapy in elderly patients and those with advanced fibrosis. At present, telaprevir + Peg-IFN- $\alpha$ -2b + ribavirin triple therapy is not approved by national medical insurance for patients with liver cirrhosis in Japan.
- 4 When telaprevir + Peg-IFN + ribavirin triple therapy fails to reduce the HCV RNA to  $\leq 3$  log copy/mL at treatment week 4, HCV RNA fails to become undetectable by treatment week 12, or HCV RNA rises  $\geq 2$  log copy/mL during therapy, treatment should be discontinued.

#### IFN- $\beta$ + ribavirin combination therapy

In a Japanese clinical trial of IFN- $\beta$  + ribavirin combination therapy in patients with HCV genotype 1 and a high viral load, the SVR rate of 24 weeks' treatment was 19%, showing non-inferiority to IFN- $\alpha$  + ribavirin therapy, with a relatively low 4% rate of discontinuation due to adverse reactions. Furthermore, a 48-week treatment period yielded a 22% SVR rate, with 17% withdrawals, in the patient group with "refractory hepatitis C and a history of depression, depressive symptoms or suspected depression", intolerant of Peg-IFN- $\alpha$  formulations.<sup>133</sup> In this way, the efficacy and safety of IFN- $\beta$  + ribavirin combination therapy have been established in patients with a history of depression, depressive symptoms or suspected depression, and should be considered in this group.

#### Recommendation:

Interferon- $\beta$  + ribavirin combination therapy should be considered in patients at risk of depression-related adverse reactions.

#### Selection of antiviral therapy for treatment-naïve patients: Genotype 1 with high viral load (Figs 1,2)

**Elderly patients.** In this patient group at high risk of hepatocellular carcinogenesis, the best possible antiviral therapy should be promptly commenced. However, the possibility of adverse reactions, and the possibility that viral eradication may not be achieved, should be thoroughly explained to the patient in advance. SVR rates for 48 weeks' Peg-IFN + ribavirin combination therapy are 40–50% in patients aged 60–64 years, similar to those aged <60, but the SVR rate falls to approximately 30% in those aged  $\geq 65$ . However, even among elderly patients, the SVR rate in early responders (HCV RNA undetectable by treatment week 12) is approximately 80%, the same as in non-elderly patients.<sup>105</sup> Furthermore, in late responders (HCV RNA undetectable between treatment weeks 13 and 24), SVR rates of approximately 50% are achieved with prolonged therapy (72 weeks) in elderly patients.<sup>118</sup> In this way, individual elderly patients show different treatment responses, and SVR rates improve with prolonged treatment durations, so it is important to conduct antiviral therapy with the above discontinuation criteria in mind.

The general rule in practice is to administer Peg-IFN + ribavirin combination therapy. Telaprevir + Peg-IFN + ribavirin triple therapy should be considered as an option if there is no anemia (Hb  $\geq 14$  g/dL) and treatment is likely to be tolerated, although the safety of this regimen has not been confirmed in patients aged  $\geq 65$  years. If IL-28B SNP minor alleles and amino acid 70 substitutions in the HCV core region have been detected, however, therapeutic efficacy can be expected to be extremely poor with all available therapies, so

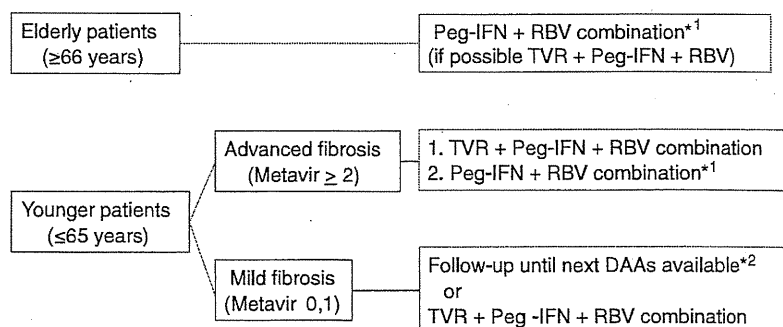
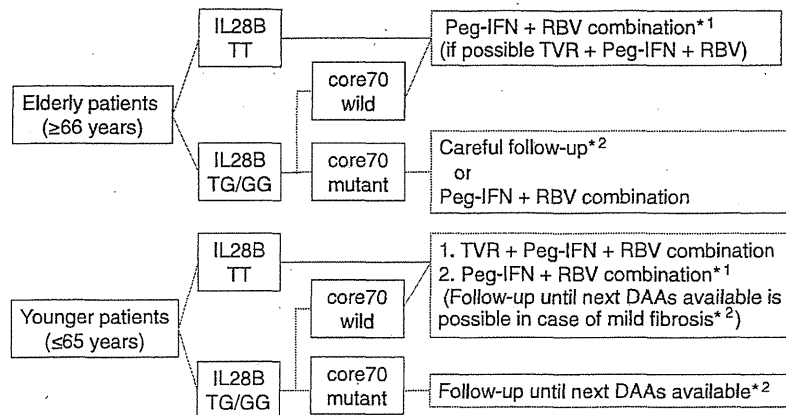

Figure 1 Patients with chronic hepatitis C genotype 1, high viral load; Principles of treatment in treatment-naïve cases, when IL28B SNP/HCV core amino acid 70 substitution cannot be tested.

\*1: Also consider IFN- $\beta$  + RBV combination therapy if depression present

\*2: In cases of abnormal ALT levels, supportive therapy or low-dose Peg-IFN/IFN therapy



\*1: Also consider IFN- $\beta$  + RBV combination therapy if depression present

\*2: In cases of abnormal ALT levels, supportive therapy or low-dose Peg-IFN/IFN therapy

Figure 2 Patients with chronic hepatitis C genotype 1, high viral load; Principles of treatment in treatment-naïve cases, when IL28B SNP/HCV core amino acid 70 substitution can be tested.

careful follow-up, with no antiviral therapy, is an option. If therapy aimed at SVR is not administered, but ALT levels are abnormal, then the above-mentioned low-dose long-term Peg-IFN or IFN therapy or supportive therapy (e.g. SNMC, UDCA) may be administered. In anemic patients (Hb <12 g/dL), Peg-IFN (IFN) therapy without ribavirin may be considered.

#### Recommendations:

- 1 Elderly patients are at high risk of developing HCC, and should commence antiviral therapy promptly.
- 2 Antiviral therapy for elderly patients should be selected with due consideration of the anticipated therapeutic efficacy and adverse reactions, and the possibility that viral eradication may not be successful should be fully explained to the patient in advance.
- 3 As a general rule, Peg-IFN + ribavirin combination therapy is the first-line treatment for treatment-naïve elderly patients.
- 4 If IL-28B minor alleles and amino acid 70 substitutions in the HCV core region have been detected in an elderly patient, careful follow-up is an option. If ALT levels are abnormal, low-dose long-term Peg-IFN/IFN therapy or supportive therapy may be administered.

**Non-elderly patients.** In non-elderly patients with a relatively low risk of HCC, testing for IL-28B SNP and amino acid substitutions in the HCV core region and ISDR should be performed if possible. Treatment with the highest possible expected therapeutic efficacy, including next generation DAAs, should be considered.

More aggressive therapy is required in patients with advanced fibrosis.

In practice, the treatment of first choice is telaprevir + Peg-IFN + ribavirin triple therapy. When tolerability is a concern, and in patients with advanced fibrosis, Peg-IFN + ribavirin combination therapy should be considered. Also, consider IFN- $\beta$  + ribavirin combination therapy in patients with depressive symptoms. For some patients with mild fibrosis and a low risk of HCC, follow-up until new therapies with higher anticipated efficacies become available is an option. Testing of IL28B SNPs and amino acid 70 substitutions in the HCV core region is useful when it is difficult to decide whether antiviral therapy should be commenced in an individual patient. If IL-28B minor alleles and amino acid 70 substitutions in the HCV core region have been detected, as a general rule, aggressive antiviral therapy is not recommended.

#### Recommendations:

- 1 In non-elderly patients with a relatively low risk of HCC, then testing for IL-28B SNP, amino acid substitutions in the HCV core region and ISDR should be performed if possible. Treatment with the highest possible expected therapeutic efficacy, including next generation DAAs, should be considered. More aggressive therapy is required in patients with advanced fibrosis, as with elderly patients, but follow-up until new therapies with higher anticipated efficacies become available is an option in non-elderly patients with mild fibrosis.

- 2 The treatment of first choice in non-elderly patients is telaprevir + Peg-IFN + ribavirin triple therapy. When tolerability is a concern and in patients with advanced fibrosis, Peg-IFN + ribavirin combination therapy should be considered.
- 3 If IL-28B minor alleles and amino acid 70 substitutions in the HCV core region have been detected, as a general rule, aggressive antiviral therapy should not be administered.

### 3.5 Initial treatment—Genotype 1 with low viral load, and Genotype 2

In patients with chronic hepatitis C, genotype 1 with low viral load and genotype 2, administered Peg-IFN + ribavirin combination therapy, little difference is seen in SVR rates according to genotype or viral load. In the United States and Europe, Peg-IFN + ribavirin combination therapy is the treatment of first choice, whereas in Japan treatment-naïve patients with low viral loads are given IFN monotherapy as first choice.

#### Genotype 1, low viral load

Patients with genotype 1 and a low viral load ( $<5.0 \log_{10}$  IU/mL using real-time PCR, HCV core antigen  $<300$  fmol/L) administered Peg-IFN monotherapy achieve  $\geq 50\%$  of SVR rates.<sup>40,134</sup> Approximately 50% of SVR rates can be achieved with standard IFN monotherapy for 24–48 weeks as well.<sup>135</sup> Peg-IFN + ribavirin combination therapy has been reported to yield SVR rates  $\geq 80\%$  in this patient group,<sup>136</sup> but is not approved by Japanese national medical insurance.

#### Genotype 2, low virus load

Patients with genotype 2 and a low viral load administered Peg-IFN monotherapy achieve SVR rates of approximately 90%.<sup>134,137</sup> Similarly high SVR rates are also seen with standard IFN monotherapy. Although not approved by medical insurance in Japan, even higher SVR rates can be achieved with Peg-IFN + ribavirin combination therapy. The standard treatment duration is 24 weeks, but this can be shortened to 8–16 weeks if HCV RNA becomes undetectable by treatment week 1 or 2.<sup>138</sup>

#### Genotype 2, high viral load

Peg-IFN + ribavirin combination therapy shows high efficacy in patients with genotype 2 and a high viral load.<sup>85,139</sup> If HCV RNA is  $<1000$  kIU/mL ( $6.0 \log_{10}$  IU/mL), viral clearance can also be expected with

Peg-IFN monotherapy. In particular, if HCV RNA becomes undetectable by treatment week 4–8, SVR rates  $\geq 80\%$  can be achieved.<sup>137</sup>

#### Recommendations:

- 1 For treatment-naïve patients with genotype 1 and a low viral load, Peg-IFN monotherapy for 24–48 weeks or standard IFN monotherapy for 24 weeks is recommended.
- 2 For treatment-naïve patients with genotype 2 and a low viral load, Peg-IFN monotherapy for 24–48 weeks or standard IFN monotherapy for 24 weeks is recommended. This can be shortened to 8–16 weeks if HCV RNA becomes undetectable by treatment week 1 or 2.
- 3 For treatment-naïve patients with genotype 2 and a high viral load, Peg-IFN + ribavirin combination therapy or IFN- $\beta$  + ribavirin therapy for 24 weeks is recommended. If there are problems with using ribavirin, Peg-IFN monotherapy may be administered for 24–48 weeks.

### 3.6 Retreatment—Genotype 1 with high viral load

Response to the previous therapy is the best indicator of the therapeutic efficacy of retreatment in patients who fail to respond to IFN/Peg-IFN + ribavirin combination therapy.<sup>140–142</sup> Failure to respond to previous therapy is broadly divided into “relapse” (HCV RNA became undetectable during treatment but reappeared following treatment) and “non-response” (HCV RNA did not become undetectable during treatment). Furthermore, “non-response” is divided into “null response”, with almost no response ( $<2 \log$  decrease in HCV RNA at treatment week 12) and “partial response” (HCV RNA did not become undetectable during treatment, but  $\geq 2 \log$  decrease at treatment week 12) (Table 2).<sup>101</sup> When combination therapy including ribavirin is administered to patients who did not have ribavirin in their previous therapy, namely, the previous therapy was IFN or Peg-IFN monotherapy, the response to previous therapy is not a strong predictor of efficacy. As a general rule, in these cases the therapy protocol in treatment-naïve patients applies. If the details of previous treatment are unknown, again the therapy protocol in treatment-naïve patients applies.

The Epic study, mainly conducted in Western countries, trialed the retreatment with 48 weeks' Peg-IFN + ribavirin combination therapy in patients who failed to respond to previous IFN/Peg-IFN + ribavirin combination therapy (genotype 1, METAVIR score F2–F4). They reported an SVR rate of 23% (56/243) in



relapsers of the previous treatment, and the even lower rate of 4% (19/431) in non-responders.<sup>142</sup> In the REPEAT study of the efficacy of extended treatment durations of Peg-IFN- $\alpha$ -2a + ribavirin combination therapy in patients who failed to respond to previous IFN/Peg-IFN- $\alpha$ -2b + ribavirin combination therapy, the SVR rate of 16% in the 72-week treatment group was higher than that of 8% for the 48-week treatment group.<sup>140</sup> In a study of response-guided retreatment of Peg-IFN + ribavirin combination therapy in patients who previously failed to respond to the same therapy, the SVR rate in relapsers was 63% (20/32) and 13% (3/24) in non-responders, whereas none of the 16 null responders achieved SVR.<sup>141</sup> In this way, in order to achieve SVR with retreatment with Peg-IFN + ribavirin combination therapy in a patient who failed to respond to previous combination therapy containing ribavirin, it is necessary that the patient not be a null responder to the previous treatment. It is also desirable that the previous treatment was not extended in duration.

The response to previous therapy is also extremely important for retreatment with telaprevir + Peg-IFN + ribavirin triple therapy. When patients with genotype 1 chronic hepatitis C who failed to respond to previous Peg-IFN + ribavirin combination therapy were administered standard telaprevir therapy (telaprevir + Peg-IFN + ribavirin triple therapy for 12 weeks, followed by Peg-IFN- $\alpha$ -2a + ribavirin dual therapy for 12 weeks; T12PR24) as retreatment, the SVR rate in relapsers of Peg-IFN + ribavirin combination therapy was 69% (29/42), and lower in non-responders at 39% (26/66) (PROVE 3 study).<sup>13</sup> In a Japanese clinical trial, if we consider only patients whose previous treatment was Peg-IFN + ribavirin combination therapy, the SVR rate was 86% (68/79) in relapsers and 28% (8/29) in non-responders.

Another clinical trial administered telaprevir + Peg-IFN + ribavirin triple therapy for 48 weeks to patients with genotype 1 chronic hepatitis C who failed to respond to previous Peg-IFN + ribavirin combination therapy (REALIZE study). They allocated patients to a group administered telaprevir + Peg-IFN + ribavirin triple therapy for 12 weeks, followed by Peg-IFN- $\alpha$ -2a + ribavirin dual therapy for 36 weeks (T12PR48); a group administered Peg-IFN- $\alpha$ -2a lead-in monotherapy for 4 weeks followed by telaprevir + Peg-IFN- $\alpha$ -2a + ribavirin triple therapy for 12 weeks then Peg-IFN- $\alpha$ -2a + ribavirin dual therapy for 32 weeks (Lead-in T12PR48); and a control group administered Peg-IFN- $\alpha$ -2a + ribavirin therapy for 48 weeks (PR48). The SVR rates for the T12PR48/Lead-in T12PR48/PR48 groups

according to response to previous therapy to Peg-IFN + ribavirin combination therapy were 83%/88%/24% for relapsers, 59%/54%/15% for partial responders and 29%/33%/5% for null responders, indicating that response to previous therapy is a strong predictor of the efficacy of triple therapy, regardless of lead-in.<sup>100</sup> A study of the relationship between IL-28B SNPs and therapeutic effect according to response to previous treatment found that for the same previous response, SVR rates were similar for major (CC) and minor (CT or TT) alleles at the IL-28B SNP (rs12980275) (relapser, 88%/85%/85%; partial responder, 63%/58%/71%; null responder, 40%/29%/31%).<sup>143</sup> In a clinical trial of retreatment with telaprevir + Peg-IFN + ribavirin triple therapy for patients with genotype 1 chronic hepatitis C who failed to respond to Peg-IFN + ribavirin combination therapy, null responders and those who failed to achieve eRVR were administered extended therapy (T12PR48), and others standard telaprevir therapy (T12PR24). The SVR rates were 97% (28/29) in relapsers, 55% (16/29) in partial responders and 37% (19/51) in null responders.<sup>144</sup>

In this way, we can see that the response to previous therapy is also an extremely important prognostic factor for retreatment with telaprevir + Peg-IFN + ribavirin triple therapy. The SVR rate for null-responders to previous therapy is only of the order of 30% for 48 weeks with telaprevir + Peg-IFN + ribavirin triple therapy, and lower SVR rates can be anticipated in Japan with 24 weeks' treatment. There are particular concerns regarding adverse reactions in elderly null-responders to previous therapy, so caution is required in considering triple therapy in this patient group.

#### **Selection of antiviral therapy for retreatment: Genotype 1 with high viral load (Figs 3,4)**

*Elderly patients.* In general, retreatment should be with Peg-IFN + ribavirin combination therapy, although telaprevir + Peg-IFN + ribavirin combination therapy should be considered if it can be tolerated. Therapeutic efficacy has been reported for retreatment with Peg-IFN + ribavirin combination therapy in non-responders to IFN + ribavirin combination therapy,<sup>145,146</sup> but SVR cannot be expected with Peg-IFN + ribavirin combination therapy in null responders to IFN + ribavirin combination therapy. Telaprevir + Peg-IFN + ribavirin combination therapy can be commenced in null responders to previous therapy, with due consideration of the discontinuation criteria. Due to concern about adverse reactions, and the fact that the anticipated therapeutic efficacy is not high, in general it is preferable to

Figure 3 Patients with chronic hepatitis C genotype 1, high viral load; Principles of treatment in retreatment cases, when details of previous treatment are unknown. If IL28B SNP/core amino acid 70 substitutions can be tested, follow the treatment guidelines in treatment-naïve patients.

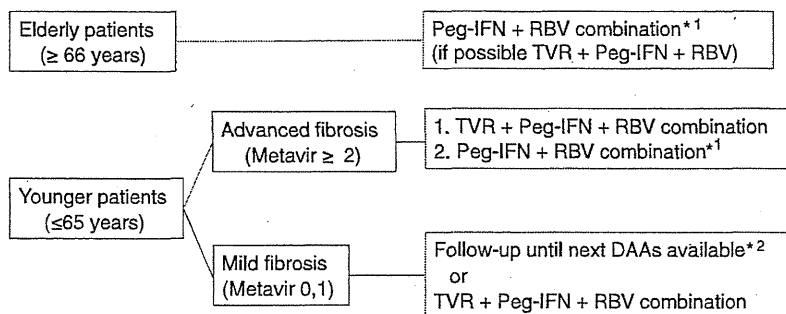

\*1: Also consider IFN- $\beta$  + RBV combination therapy if depression present

\*2: In cases of abnormal ALT levels, supportive therapy or low-dose Peg-IFN/IFN therapy

wait for the next generation DAAs. On the other hand, elderly patients are at high risk of developing HCC, so if viral clearance cannot be achieved, low-dose long-term Peg-IFN or IFN therapy, or supportive therapy (e.g. SNMC, UDCA) should be administered with the aims of biochemical improvement and inhibiting hepatocellular carcinogenesis.

**Non-elderly patients.** As mentioned above, in Japanese studies, retreatment with triple therapy in relapsers following previous Peg-IFN + ribavirin combination therapy is highly efficacious, with an SVR rate of 86%.<sup>9,147</sup> In all non-responders to Peg-IFN + ribavirin combination therapy, the SVR rate was 28%, although better rates can be anticipated in partial responders. Accordingly, the treatment of first choice in relapsers and partial responders to previous therapy is telaprevir + Peg-IFN + ribavirin triple therapy. If triple

therapy cannot be tolerated, retreatment with Peg-IFN + ribavirin combination therapy should be considered in patients with advanced fibrosis, although waiting for the next generation DAAs is an option in patients with mild fibrosis.

In null responders to previous therapy, the anticipated therapeutic efficacy for 24 weeks' triple therapy is rather low.<sup>9</sup> Accordingly, telaprevir + Peg-IFN + ribavirin triple therapy should be considered in patients with advanced fibrosis, but for patients with mild fibrosis in general we should wait for the next generation DAAs.

#### Recommendations:

1 Response to the previous therapy is the best indicator of the therapeutic efficacy of retreatment in patients with chronic hepatitis C genotype 1 and a high viral load who failed to respond to previous

Figure 4 Patients with chronic hepatitis C genotype 1, high viral load; Principles of treatment in retreatment cases, when details of previous treatment are known.

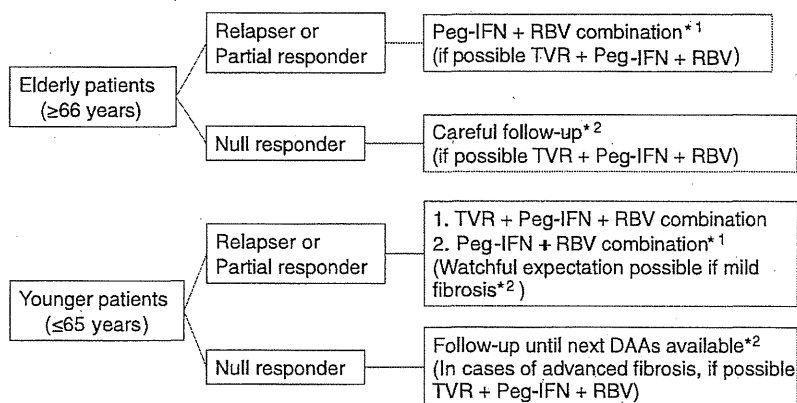

\*1: Also consider IFN- $\beta$  + RBV combination therapy if depression present

\*2: In cases of abnormal ALT levels, supportive therapy or low-dose Peg-IFN/IFN therapy

*IFN/Peg-IFN + ribavirin combination therapy. In general, follow the therapy protocol in treatment-naïve patients for retreatment with combination therapy including ribavirin in patients previously administered IFN or Peg-IFN monotherapy.*

- 2 *Retreatment in elderly patients with genotype 1 and high viral load: for relapsers and partial responders to previous therapy, retreatment should be with Peg-IFN + ribavirin combination therapy in general, although telaprevir + Peg-IFN + ribavirin combination therapy should be considered if it can be tolerated.*
- 3 *Retreatment in elderly patients with genotype 1 and high viral load: for null responders to previous therapy, as an adequate antiviral effect cannot be expected, careful follow-up should be considered. If ALT levels are abnormal, low-dose long-term Peg-IFN/IFN therapy or supportive therapy should be administered.*
- 4 *Retreatment in non-elderly patients with genotype 1 and high viral load: for relapsers and partial responders to previous therapy, the treatment of first choice is telaprevir + Peg-IFN + ribavirin combination therapy. If triple therapy cannot be tolerated, retreatment with Peg-IFN + ribavirin combination therapy should be considered in patients with advanced fibrosis, although waiting for the next generation DAAs is an option in patients with mild fibrosis.*
- 5 *Retreatment in non-elderly patients with genotype 1 and high viral load: for null responders to previous therapy, telaprevir + Peg-IFN + ribavirin triple therapy should be considered in patients with advanced fibrosis, if tolerated, but for patients with mild fibrosis, we should wait for the next generation DAAs.*

### 3.7 Retreatment—Genotype 1 with low viral load, and Genotype 2

#### Genotype 1, low viral load

If the previous treatment was IFN or Peg-IFN monotherapy, as a general rule, retreatment should be with Peg-IFN + ribavirin combination therapy. When Peg-IFN- $\alpha$  is contraindicated due to depression or depressive symptoms, IFN- $\beta$  can be used instead of Peg-IFN.<sup>26</sup> When the previous therapy included ribavirin, telaprevir + Peg-IFN + ribavirin combination therapy should be used. If triple therapy cannot be tolerated, then consider retreatment with Peg-IFN + ribavirin combination therapy, although there is no clear evidence regarding the efficacy of this therapy as retreatment.

#### Genotype 2, high viral load

If the previous treatment was IFN or Peg-IFN monotherapy, retreatment should be with Peg-IFN + ribavirin combination therapy (24 weeks). When the previous therapy included ribavirin, treatment with Peg-IFN + ribavirin therapy (24–48 weeks) should be considered. SVR rates  $\geq 50\%$  have been reported.<sup>141,148</sup> When Peg-IFN- $\alpha$  is contraindicated due to depression or depressive symptoms, IFN- $\beta$  can be used instead of Peg-IFN.<sup>26</sup>

#### Genotype 2, low viral load

If the previous treatment was IFN or Peg-IFN monotherapy, retreatment should be with Peg-IFN + ribavirin combination therapy (24 weeks). When the previous therapy included ribavirin, treatment with Peg-IFN + ribavirin therapy (24–48 weeks) should be considered. High SVR rates comparable to those achieved with initial treatment have been reported.<sup>85,136</sup> As with patients with genotype 2 and a high viral load, if Peg-IFN- $\alpha$  is contraindicated due to depression or depressive symptoms, IFN- $\beta$  can be used instead of Peg-IFN.<sup>26</sup>

#### Recommendations:

- 1 *In patients with genotype 1 and a low viral load, if the previous treatment was IFN or Peg-IFN monotherapy, as a general rule, retreatment should be with Peg-IFN + ribavirin combination therapy. When the previous therapy included ribavirin, telaprevir + Peg-IFN + ribavirin combination therapy should be used. If triple therapy cannot be tolerated, then consider retreatment with Peg-IFN + ribavirin combination therapy in patients with advanced fibrosis.*
- 2 *In patients with genotype 2, regardless of the viral load, if the previous treatment was IFN or Peg-IFN monotherapy, retreatment should be with Peg-IFN + ribavirin combination therapy (24 weeks). When the previous therapy included ribavirin, treatment with Peg-IFN + ribavirin therapy (24–48 weeks) should be considered.*
- 3 *In any patient group, in patients unable to tolerate Peg-IFN- $\alpha$  due to depression or depressive symptoms, IFN- $\beta$  + ribavirin combination therapy should be administered for 28–48 weeks.*

### 3.8 Treatment of patients with liver cirrhosis

#### IFN therapy for compensated cirrhosis

The state in which the hepatic functional reserve is preserved, and there is no evidence of liver failure such as jaundice, ascites, hepatoencephalopathy or esophageal varices (Child–Pugh class A) is called compensated

cirrhosis, and when there is evidence of liver failure (Child–Pugh class B, C), it is called decompensated cirrhosis. Patients with liver cirrhosis accompanying severe fibrosis are a high-risk group for hepatocellular carcinogenesis. Even if they avoid developing HCC, the prognosis is poor if they develop liver failure. Accordingly, the objective of treatment for liver cirrhosis is to prevent both HCC and liver failure, and aggressive antiviral therapy is highly necessary in patients with compensated cirrhosis. Viral eradication through IFN therapy in patients with compensated cirrhosis can be expected to reduce the risk of HCC and liver failure.<sup>8</sup> However, patients with advanced hepatic fibrosis are IFN-resistant, and pancytopenia associated with hypersplenism complicating liver cirrhosis impedes IFN therapy.<sup>78,79</sup> When a virological response is not achieved with IFN therapy, a changeover to low-dose long-term IFN therapy should be made with the improving ALT levels and inhibiting hepatocellular carcinogenesis. The safety of telaprevir + Peg-IFN + ribavirin triple therapy has not been established in patients with cirrhosis, and is not approved by national medical insurance for this patient group.

*Peg-IFN + ribavirin combination therapy.* For some time now, outside of Japan, the standard treatment for patients with compensated cirrhosis has been the same as for chronic hepatitis C, Peg-IFN + ribavirin combination therapy.<sup>149,150</sup> In a trial comparing Peg-IFN- $\alpha$ -2b (1.0  $\mu$ g/kg per week) monotherapy and combination therapy including ribavirin (800 mg/day), mainly in patients with compensated cirrhosis, higher efficacy was seen with the latter (SVR rates, 9.8% vs 21.6%,  $P=0.06$ ). The SVR rate was 67% in patients with genotypes 2 and 3, significantly higher than that of 11% in patients with genotypes 1 and 4 ( $P=0.001$ ). Progression towards liver failure was significantly less in patients achieving SVR than in non-responders (6.2% vs 38.3%,  $P=0.03$ ).<sup>151</sup> In a clinical trial of Peg-IFN- $\alpha$ -2a 180  $\mu$ g/kg/week and ribavirin 600–1200 mg/day combination therapy, solely with patients with compensated cirrhosis, a significantly higher SVR rate was seen with genotypes 2 and 3 than with genotypes 1 and 4 (32% vs 58%,  $P=0.04$ ).<sup>150</sup> In 2011, Peg-IFN- $\alpha$ -2b or Peg-IFN- $\alpha$ -2a + ribavirin combination therapy has been approved in Japan by national medical insurance for the treatment of patients with compensated cirrhosis, irrespective of viral load or genotype. In a Japanese clinical trial of Peg-IFN- $\alpha$ -2b 1.0  $\mu$ g/kg/week in combination with ribavirin for 48 weeks in patients with compensated HCV cirrhosis, the SVR rate was 22% (15/69) in patients with

genotype 1 and a high viral load, and 79% (26/33) in other patients, indicating high efficacy in all groups other than genotype 1 with a high viral load. In a study of 48 weeks of a combination of Peg-IFN- $\alpha$ -2a in two doses, 90 and 180  $\mu$ g/week, with ribavirin, the SVR rate was 28% (17/61) in the 90- $\mu$ g group, and 27% (17/63) in the 180- $\mu$ g group, with no difference seen between groups. In the 90- $\mu$ g group, the SVR was 21% (10/48) in patients with genotype 1 and 50% (6/12) in those with genotype 2, showing high efficacy against the latter.<sup>152</sup>

In patients with compensated cirrhosis, where the doses of Peg-IFN- $\alpha$  and ribavirin are limited by the high degree of fibrosis, extended courses of combination therapy are required to achieve SVR. The HCV RNA dynamics following commencement of Peg-IFN + ribavirin combination therapy are also a good indicator of SVR in patients with compensated cirrhosis.<sup>153,154</sup> Accordingly, as with chronic hepatitis C, response-guided therapy altering the duration of treatment in accordance with the response to Peg-IFN + ribavirin therapy is useful. If HCV RNA does not become undetectable by treatment week 12 and viral clearance cannot be achieved, as with chronic hepatitis C, consideration should be given to a changeover to low-dose long-term Peg-IFN therapy with the aim of inhibiting hepatocellular carcinogenesis. Adverse reactions to Peg-IFN + ribavirin combination therapy in patients with compensated cirrhosis such as influenza-like-syndrome, depression, lethargy and cytopenia are common, but there are no great differences with chronic hepatitis in terms of safety and tolerability.<sup>149,150</sup> However, pancytopenia associated with hypersplenism may be present in the background, so reduction in the dose of both agents is often required due to severe cytopenias, including anemia, neutropenia and thrombocytopenia.<sup>151,153</sup>

The standard dose for Peg-IFN- $\alpha$ -2b in the treatment of patients with compensated cirrhosis is 1.0  $\mu$ g/kg/week, and the criteria for dose reduction and discontinuation during treatment are as follows: halve the dose in the case of a neutrophil count  $<750/\mu$ L or platelet count  $<50\ 000/\mu$ L; and cease both Peg-IFN- $\alpha$ -2b and ribavirin in the case of a neutrophil count  $<500/\mu$ L, platelet count  $<35\ 000/\mu$ L or Hb  $<8.5$  g/dL.<sup>155</sup> When the pretreatment Hb is  $\geq 14$  g/dL, the daily dose of ribavirin is 600 mg for patients weighing  $\leq 60$  kg, 800 mg for 61–80 kg and 1000 mg for  $>80$  kg. If the pretreatment Hb is  $<14$  g/dL, the starting dose of ribavirin is reduced by 200 mg, irrespective of weight.

The criteria for ribavirin dose reduction or discontinuation when a decline in Hb occurs during treatment are: