

the ABI PRISM 7000. Data were normalized against *GAPDH* (catalog No: 4326317E) for *MEG3* and *MEG8* and against *RNU48* (assay ID: 0010006) for the remaining *miRs*. The expression studies were performed three times for each sample.

To examine the imprinting status of *MEG3* in the leukocytes of patient 2, direct sequence data for informative cSNPs were compared between gDNA and cDNA. To analyze the imprinting status of *RTL1* in the placental sample of patient 1 and that of *DLK1* in the pituitary and adrenal samples of patient 3, RT-PCR products containing exonic cSNPs informative for the parental origin were subcloned with TOPO TA Cloning Kit, and multiple clones were subjected to direct sequencing on the CEQ 8000 autosequencer. Furthermore, *MEG3* expression pattern was examined using leukocyte gDNA and cDNA samples from multiple normal subjects and leukocyte gDNA samples from their mothers, and *RTL1* expression pattern was analyzed using gDNA and cDNA samples from multiple fresh normal placentas and leukocyte gDNA from the mothers.

**Acknowledgments**

This work was supported by grants from the Ministry of Health, Labor, and Welfare, from the Ministry of Education, Science, Sports and Culture, and from Takeda Science Foundation.

**Author Contributions**

Conceived and designed the experiments: MK ACF-S TO. Performed the experiments: MK MF KM FK. Contributed reagents/materials/analysis tool: MJO AJG YW OA NM KM TO. Wrote the paper: TO.

**Competing Interests**

The authors have declared that no competing interests exist.

## References

1. da Rocha ST, Edwards CA, Ito M, Ogata T, Ferguson-Smith AC (2008) Genomic imprinting at the mammalian Dlk1-Dio3 domain. *Trends Genet* 24: 306–316.
2. Kagami M, Sekita Y, Nishimura G, Irie M, Kato F, et al. (2008) Deletions and epimutations affecting the human 14q32.2 imprinted region in individuals with paternal and maternal upd(14)-like phenotypes. *Nat Genet* 40: 237–242.
3. Kagami M, Yamazawa K, Matsubara K, Matsuo N, Ogata T (2008) Placentomegaly in paternal uniparental disomy for human chromosome 14. *Placenta* 29: 760–761.
4. Kotzot D (2004) Maternal uniparental disomy 14 dissection of the phenotype with respect to rare autosomal recessively inherited traits, trisomy mosaicism, and genomic imprinting. *Ann Genet* 47: 251–260.
5. Temple IK, Shrubbs V, Lever M, Bullman H, Mackay DJ (2007) Isolated imprinting mutation of the DLK1/GTL2 locus associated with a clinical presentation of maternal uniparental disomy of chromosome 14. *J Med Genet* 44: 637–640.
6. Buiting K, Kanber D, Martín-Subero JI, Lieb W, Terhal P, et al. (2008) Clinical features of maternal uniparental disomy 14 in patients with an epimutation and a deletion of the imprinted DLK1/GTL2 gene cluster. *Hum Mutat* 29: 1141–1146.
7. Hosoki K, Ogata T, Kagami M, Tanaka T, Saitoh S (2008) Epimutation (hypomethylation) affecting the chromosome 14q32.2 imprinted region in a girl with upd(14)mat-like phenotype. *Eur J Hum Genet* 16: 1019–1023.
8. Zechner U, Kohlschmidt N, Rittner G, Damatova N, Beyer V, et al. (2009) Epimutation at human chromosome 14q32.2 in a boy with a upd(14)mat-like clinical phenotype. *Clin Genet* 75: 251–258.
9. Li E, Beard C, Jaenisch R (1993) Role for DNA methylation in genomic imprinting. *Nature* 366: 362–365.
10. Suwa S, Tachibana K, Maesaka H, Tanaka T, Yokoya S (1992) Longitudinal standards for height and height velocity for Japanese children from birth to maturity. *Clin Pediatr Endocrinol* 1: 5–13.

11. Matsuo N (1993) Skeletal and sexual maturation in Japanese children. *Clin Pediatr Endocrinol* 2[suppl]: 1–4.
12. Tsai CE, Lin SP, Ito M, Takagi N, Takada S, et al. (2002) Genomic imprinting contributes to thyroid hormone metabolism in the mouse embryo. *Curr Biol* 12: 1221–1226.
13. Rosa AL, Wu YQ, Kwabi-Addo B, Coveler KJ, Reid Sutton V, et al. (2005) Allele-specific methylation of a functional CTCF binding site upstream of MEG3 in the human imprinted domain of 14q32. *Chromosome Res* 13: 809–818.
14. Wylie AA, Murphy SK, Orton TC, Jirtle RL (2000) Novel imprinted DLK1/GTL2 domain on human chromosome 14 contains motifs that mimic those implicated in IGF2/H19 regulation. *Genome Res* 10: 1711–1718.
15. Tierling S, Dalbert S, Schoppenhorst S, Tsai CE, Oligier S, et al. (2007) High-resolution map and imprinting analysis of the Gtl2-Dnchc1 domain on mouse chromosome 12. *Genomics* 87: 225–235.
16. Ohlsson R, Renkawitz R, Lobanekov V (2001) CTCF is a uniquely versatile transcription regulator linked to epigenetics and disease. *Trends Genet* 17: 520–527.
17. Hark AT, Schoenherr CJ, Katz DJ, Ingram RS, Levorse JM, et al. (2000) CTCF mediates methylation-sensitive enhancer-blocking activity at the H19/Igf2 locus. *Nature* 405: 486–489.
18. Kanduri C, Pant V, Loukinov D, Pugacheva E, Qi CF, et al. (2000) Functional association of CTCF with the insulator upstream of the H19 gene is parent of origin-specific and methylation-sensitive. *Curr Biol* 10: 853–856.
19. da Rocha ST, Tevendale M, Knowles E, Takada S, Watkins M, et al. (2007) Restricted co-expression of Dlk1 and the reciprocally imprinted non-coding RNA, Gtl2: implications for cis-acting control. *Dev Biol* 306: 810–823.
20. Wan LB, Pan H, Hannenhalli S, Cheng Y, Ma J, et al. (2008) Maternal depletion of CTCF reveals multiple functions during oocyte and preimplantation embryo development. *Development* 135: 2729–2738.
21. Lin SP, Youngson N, Takada S, Seitz H, Reik W, et al. (2003) Asymmetric regulation of imprinting on the maternal and paternal chromosomes at the Dlk1-Gtl2 imprinted cluster

- on mouse chromosome 12. *Nat Genet* 35: 97–102.
22. Moon YS, Smas CM, Lee K, Villena JA, Kim KH, et al. (2002) Mice lacking paternally expressed *Pref-1/Dlk1* display growth retardation and accelerated adiposity. *Mol Cell Biol* 22: 5585–5592.
  23. Sekita Y, Wagatsuma H, Nakamura K, Ono R, Kagami M, et al. (2008) Role of retrotransposon-derived imprinted gene, *Rtl1*, in the fetomaternal interface of mouse placenta. *Nat Genet* 40: 243–248.
  24. Seitz H, Youngson N, Lin SP, Dalbert S, Paulsen M, et al. (2003) Imprinted microRNA genes transcribed antisense to a reciprocally imprinted retrotransposon-like gene. *Nat Genet* 34: 261–262.
  25. Davis E, Caiment F, Tordoix X, Cavaille J, Ferguson-Smith A, et al. (2005) RNAi-mediated allelic trans-interaction at the imprinted *Rtl1/Peg11* locus. *Curr Biol* 15: 743–749.
  26. Lin SP, Coan P, da Rocha ST, Seitz H, Cavaille J, et al. (2007) Differential regulation of imprinting in the murine embryo and placenta by the *Dlk1-Dio3* imprinting control region. *Development* 134: 417–426.
  27. Coan PM, Burton GJ, Ferguson-Smith AC (2005) Imprinted genes in the placenta--a review. *Placenta* 26 Suppl A: S10–20.
  28. Georgiades P, Watkins M, Surani MA, Ferguson-Smith AC (2000) Parental origin-specific developmental defects in mice with uniparental disomy for chromosome 12. *Development* 127: 4719–4728.
  29. Takada S, Paulsen M, Tevendale M, Tsai CE, Kelsey G, et al. (2002) Epigenetic analysis of the *Dlk1-Gtl2* imprinted domain on mouse chromosome 12: implications for imprinting control from comparison with *Igf2-H19*. *Hum Mol Genet* 11: 77–86.
  30. Takada S, Tevendale M, Baker J, Georgiades P, Campbell E, et al. (2000) *Delta-like* and *gtl2* are reciprocally expressed, differentially methylated linked imprinted genes on mouse chromosome 12. *Curr Biol* 10: 1135–1138.
  31. Takahashi N, Okamoto A, Kobayashi R, Shirai M, Obata Y, et al. (2009) Deletion of *Gtl2*, imprinted non-coding RNA, with its differentially methylated region induces lethal parent-origin-dependent defects in mice. *Hum Mol Genet* 18: 1879–1888.

32. Lewis A, Mitsuya K, Umlauf D, Smith P, Dean W, et al. (2004) Imprinting on distal chromosome 7 in the placenta involves repressive histone methylation independent of DNA methylation. *Nat Genet* 36: 1291–1295.
33. Umlauf D, Goto Y, Cao R, Cerqueira F, Wagschal A, et al. (2004) Imprinting along the *Kcnq1* domain on mouse chromosome 7 involves repressive histone methylation and recruitment of Polycomb group complexes. *Nat Genet* 36: 1296–1300.
34. Sekita Y, Wagatsuma H, Irie M, Kobayashi S, Kohda T, et al. (2006) Aberrant regulation of imprinted gene expression in *Gtl2lacZ* mice. *Cytogenet. Genome Res* 113: 223–229.
35. Steshina EY, Carr MS, Glick EA, Yevtdiyenko A, Appelbe OK, et al. (2006) Loss of imprinting at the *Dlk1-Gtl2* locus caused by insertional mutagenesis in the *Gtl2* 5' region. *BMC Genet* 7: 44.
36. Charlier C, Segers K, Karim L, Shay T, Gyapay G, et al. (2001) The callipyge mutation enhances the expression of coregulated imprinted genes in cis without affecting their imprinting status. *Nat Genet* 27: 367–369.
37. Georges M, Charlier C, Cockett N (2003) The callipyge locus: evidence for the trans interaction of reciprocally imprinted genes. *Trends Genet* 19: 248–252.

## Figure Legends

**Figure 1.** Clinical phenotypes of patients 1 and 3 at birth.

Both patients have bell shaped thorax with coat hanger appearance of the ribs and omphalocele. In patient 1, histological examination of the placenta shows proliferation of dilated and congested chorionic villi, as has previously been observed in a case with upd(14)pat [2]. The horizontal black bar indicates 100  $\mu$ m.

**Figure 2.** Physical map of the 14q32.2 imprinted region and the deleted segments in patients 1–3 (shaded in gray). *PEGs* are shown in blue, *MEGs* in red, and the IG-DMR (CG4 and CG6) and the *MEG3*-DMR (CG7) in green. It remains to be clarified whether *DIO3* is a *PEG*, although mouse *Dio3* is known to be preferentially but not exclusively expressed from a paternally derived chromosome [12]. For *MEG3*, the isoform 2 with nine exons (red bars) and eight introns (light red segment) is shown (Ensembl; <http://www.ensembl.org/index.html>). Electrochromatograms represent the fusion point in patients 1 and 2, and the fusion point accompanied by insertion of a 66 bp segment (highlighted in blue) with a sequence identical to that within *MEG3* intron 5 (the blue bar) in patient 3. Since PCR amplification with primers flanking the 66 bp segment at *MEG3* intron 5 has produced a 194 bp single band in patient 3 as well as in a control subject (shown in the box), this indicates that the 66 bp segment at the fusion point is caused by a duplicated insertion rather than by a transfer from intron 5 to the fusion point (if the 66 bp is transferred from the original position, a 128 bp band as well as a 194 bp band should be present in patient 3) (the marker size: 100, 200, and 300 bp). In the FISH images, the red signals (arrows) have been identified by the FISH-1 probe and the FISH-2 probe, and the light green signals (arrowheads) by the RP11-566I2 probe for 14q12 used as an internal control. The faint signal detected by the FISH-2 probe in patient 3 is consistent with the preservation of a ~1.2 kb region identified by the centromeric portion of the FISH-2 probe.

**Figure 3.** Methylation analysis. Filled and open circles indicate methylated and unmethylated cytosines at the CpG dinucleotides, respectively.

- (A) Structure of CG4 and CG6 (the IG-DMR) and CG7 (the *MEG3*-DMR), and sequence of the putative CTCF binding sites [13]. Pat: paternally derived chromosome; and Mat: maternally derived chromosome. The PCR products for CG4 (311 bp) harbor 6 CpG dinucleotides and a G/A SNP (*rs12437020*), and are digested with *Bst*UI into three fragment (33 bp, 18 bp, and 260 bp) when the cytosines at the first and the second CpG dinucleotides and the fourth and the fifth CpG dinucleotides (indicated with orange rectangles) are methylated. The PCR products for CG6 (428 bp) carry 19 CpG dinucleotides and a C/T SNP (*rs10133627*), and are digested with *Taq*I into two fragment (189 bp and 239 bp) when the cytosine at the 9th CpG dinucleotide (indicated with an orange rectangle) is methylated. The PCR products for CG7 harbor 7 CpG dinucleotides, and are digested with *Bst*UI into two fragment (56 bp and 112 bp) when the cytosines at the fourth and the fifth CpG dinucleotides (indicated with orange rectangles) are methylated. These enzymes have been utilized for combined bisulfite restriction analysis (COBRA). For the putative CTCF binding sites A–G, the consensus CTCF binding motifs are shown in red letters; the cytosine residues at the CpG dinucleotides within the CTCF binding motifs are highlighted in blue, and those outside the CTCF binding motifs are highlighted in green.
- (B) Methylation analysis of CG4, CG6, and CG7. Left part shows bisulfite sequencing data. The SNP typing data are also denoted for CG4 and CG6. The circles highlighted in orange correspond to those shown in Figure 3A. The relatively long CG6 was not amplified from the formalin-fixed and paraffin-embedded placental samples, probably because of the degradation of genomic DNA. Note that CG4 is differentially methylated in a control placenta and is massively hypermethylated in a upd(14)pat placenta, whereas CG7 is rather hypomethylated in a upd(14)pat placenta as well as in a control placenta. Right part shows COBRA data. U: unmethylated clone specific bands (311 bp for CG4, 428 bp for CG6, and 168 bp for CG7); and M: methylated clone specific bands (260 bp for CG4, 239 bp and 189 bp for CG6, and 112 bp and 56 bp for CG7). The results reproduce of the bisulfite sequencing data, and delineate normal findings of the father of patient 1 and the parents of patient 3.
- (C) Methylation analysis of the sites A–G. Left part shows bisulfite sequencing data, using



leukocyte genomic DNA samples. Since PCR products for the site B contain a C/A SNP (*rs11627993*), genotyping data are also indicated. The circles highlighted in blue correspond to those shown in Figure 3A. The sites C and D exhibit clear DMRs. Right part indicates the results of the sites C and D using leukocyte and/or placental genomic DNA samples. The findings are similar to those of CG7.

**Figure 4.** Expression analysis.

- (A) Reverse transcriptase (RT)-PCR analysis. L: leukocytes; SF: skin fibroblasts; and P: placenta. The relatively weak *GAPDH* expression for the formalin-fixed and paraffin-embedded placenta of patient 1 indicates considerable mRNA degradation. Since a single exon was amplified for *DLK1* and *RTL1*, PCR was performed with and without RT for the placenta of patient 1, to exclude the possibility of false positive results caused by genomic DNA contamination.
- (B) Quantitative real-time PCR (q-PCR) analysis of *MEG3*, *MEG8*, and *miRNAs*, using fresh skin fibroblasts (SF) of patient 3 and four control neonates. Of the examined *MEGs*, *miR433* and *miR127* are encoded by *RTL1as*.
- (C) RT-PCR analysis for the formalin-fixed and paraffin-embedded pituitary (Pit.) and the adrenal (Ad.) in patient 3. The bands for *DLK1* are detected in the presence of RT and undetected in the absence of RT, thereby excluding contamination of genomic DNA.
- (D) Monoallelic *MEG3* expression in the leukocytes of patient 2. The three cSNPs are present in a heterozygous status in gDNA and in a hemizygous status in cDNA. D: direct sequence.
- (E) Biparental *RTL1* expression in the placenta of patient 1 and biparental *DLK1* expression in the pituitary and adrenal of patient 3. D: direct sequence; and S: subcloned sequence. In patient 1, genotyping of *RTL1* cSNP (*rs6575805*) using gDNA indicates maternal origin of the “C” allele and paternal origin of the “T” allele, and sequencing analysis using cDNA confirms expression of maternally as well as paternally derived *RTL1*. Similarly, in patient 3, genotyping of *DLK1* cSNP (*rs1802710*) using gDNA denotes maternal origin of the “C” allele and paternal origin of the “T” alleles, and sequencing analysis using cDNA confirms expression of maternally as well as paternally inherited *DLK1*.

**Figure 5.** Schematic representation of the observed and predicted methylation and expression patterns. Deleted regions in patients 1–3 are indicated by stippled rectangles. P: paternally derived chromosome; and M: maternally derived chromosome. Representative imprinted genes are shown; these genes are known to be imprinted in the body and the placenta [2,14] (see also Figure S2). Placental samples have not been obtained in patients 2 and 3 (highlighted with light green backgrounds). Thick arrows for *RTL1* in patients 1 and 3 represent increased *RTL1* expression that is ascribed to loss of functional microRNA-containing *RTL1as* as a repressor for *RTL1* [18,20,21]; this phenomenon has been indicated in placentas with upd(14)pat and an epimutation and a microdeletion involving the two DMRs (Figure S3A and S3C) [2]. *MEG3* and *RTL1as* that are disrupted or predicted to have become silent on the maternally derived chromosome are written in gray. *DLKI* that may have been affected due to impairment of a *cis*-acting regulatory element (shown in purple circles) on the paternally derived or paternalized chromosome is indicated in black. Filled and open circles represent hypermethylated and hypomethylated DMRs, respectively; since the *MEG3*-DMR is rather hypomethylated and regarded as non-DMR in the placenta [2] (see also Figure 3), it is painted in gray.

**Table 1.** Clinical Features in Patients 1 and 3.

	Patient 1	Patient 3	Upd(14)pat (n=20) <sup>c</sup>
Present age	5.5 months	Deceased at 4 days	0–9 years
Sex	Female	Female	Male:Female=9:11
Karyotype	46,XX	46,XX	
Pregnancy and delivery			
Gestational age (weeks)	33	28	28–37
Delivery	Caesarean	Vaginal	Vaginal:Caesarean=6:7
Polyhydramnios	Yes	No	20/20 (<28) <sup>d</sup>
Amnioreduction (weeks)	2x (28, 30)	No	6/6
Placentomegaly	Yes	No	10/10
Growth pattern			
Prenatal growth failure	No	No	1/13
Birth length (cm)	43 (WNR) <sup>a</sup>	34 (WNR) <sup>a</sup>	
Birth weight (kg)	2.84 (>90 centile) <sup>a</sup>	1.32 (WNR) <sup>a</sup>	
Postnatal growth failure	Yes	...	5/6
Present stature (cm)	56.3 (–3.0 SD) <sup>b</sup>	...	
Present weight (kg)	5.02 (–3.0 SD) <sup>b</sup>	...	
Characteristic face			
Frontal bossing	No	Yes	5/7
Hairy forehead	Yes	Yes	9/10
Blepharophimosis	Yes	No	14/15
Depressed nasal bridge	Yes	Yes	13/13
Anteverted nares	Yes	No	6/10
Small ears	Yes	Yes	11/12
Protruding philtrum	Yes	No	15/15
Puckered lips	No	No	3/10
Micrognathia	Yes	Yes	11/12
Thoracic abnormality			
Bell-shaped thorax	Yes	Yes	17/17
Mechanical ventilation	Yes	Yes	17/17
Abdominal wall defect			
Diastasis recti	...	...	15/17
Omphalocele	Yes	Yes	2/17 <sup>e</sup>
Others			
Short webbed neck	Yes	Yes	14/14
Cardiac disease	No	Yes (PDA)	5/10
Inguinal hernia	No	No	2/6
Coxa valga	Yes	No	3/4
Joint contractures	Yes	No	8/10
Kyphoscoliosis	No	No	4/7
Extra features		Hydronephrosis (bilateral)	

WNR: within the normal range; SD: standard deviation; and PDA: patent ductus arteriosus.

<sup>a</sup> Assessed by the gestational age- and sex-matched Japanese reference data from the Ministry of Health, Labor, and Welfare (<http://www.dbtk.mhlw.go.jp/toukei/>).

<sup>b</sup> Assessed by the age- and sex-matched Japanese reference data [10].

<sup>c</sup> In the column summarizing the clinical features of 20 patients with upd(14)pat, the denominators indicate the number of cases examined for the presence or absence of each feature, and the numerators represent the number of cases assessed to be positive for that feature; thus, the differences between the denominators and the numerators denote the number of cases evaluated to be negative for that feature (adopted from reference [2]).

<sup>d</sup> Polyhydramnios has been identified by 28 weeks of gestation.

<sup>e</sup> Omphalocele is present in two cases with upd(14)pat and in two cases with epimutations [2].

**Table 2.** Clinical Features in Patient 2.

	Patient 2 The mother of patient 1	Upd(14)mat (n=35) <sup>h</sup> Sporadic
Age	27 years	0–30 years
Sex	Female	Male:Female=17:18
Karyotype	46,XX	
Pregnancy and delivery		
Premature delivery	No	10/25
Gestational age (weeks)	40	
Growth pattern		
Prenatal growth failure	No	24/27
Birth length (cm)	48.0 (−0.7 SD) <sup>a</sup>	
Birth weight (kg)	3.1 (−0.1 SD) <sup>a</sup>	
Postnatal growth failure	Yes	26/32
Present stature (cm)	146 (−2.2 SD) <sup>b</sup>	
Present weight (kg)	74.0 (+2.6 SD) <sup>b</sup>	
Pubertal development		
Early onset of puberty	No	14/16
Menarche (years)	12.0 (−0.2 SD) <sup>c</sup>	
Others		
Mental retardation	No	10/27
Obesity (BMI)	Yes (35)	14/34
Hypotonia	Equivocal <sup>d</sup>	25/28
Facial dysmorphism	Equivocal <sup>e</sup>	23/35
Small hands	Yes	24/27
Scoliosis	No	5/19
Remarks	Spontaneous abortions (3x) <sup>f</sup>	
Parental phenotype	Short stature <sup>g</sup>	

SD: standard deviation; BMI: body mass index.

<sup>a</sup> Assessed by the gestational age- and sex-matched Japanese reference data from the Ministry of Health, Labor, and Welfare (<http://www.dbtk.mhlw.go.jp/toukei/>).

<sup>b</sup> Assessed by the age- and sex-matched Japanese reference data [10].

<sup>c</sup> The menarchial age in Japanese girls is 12.25±1.25 years [11].

<sup>d</sup> Allegedly, she had hypotonia during infancy.

<sup>e</sup> Patient 2 exhibits mild frontal bossing and shallow orbits.

<sup>f</sup> Spontaneous abortions during the first trimester of the pregnancy; patient 2 also produced two normal boys.

<sup>g</sup> The paternal height is 155 cm (−3.0 SD), and the maternal height is 146 cm (−2.2 SD).

<sup>h</sup> In the column summarizing the clinical features of 35 cases with upd(14)mat, the denominators indicate the number of cases examined for the presence or absence of each feature, and the numerators represent the number of cases assessed to be positive for that feature; thus, the differences between the denominators and the numerators denote the number of cases evaluated to be negative for that feature (adopted from reference [2]).

**Table 3.** Clinical and molecular findings in mice with maternally inherited  $\Delta IG$ -DMR and  $\Delta Git2$ -DMR

and those with PatDi(12).

	Wildtype	PatDi(12)	$\Delta$ IG-DMR (~4.15 kb) <sup>a</sup>	$\Delta$ Gtl2-DMR (~10 kb) <sup>b</sup> Neomycin cassette (+)
<b>&lt;Body&gt;</b>				
Phenotype	Normal	Abnormal <sup>c</sup>	PatDi(12) phenotype <sup>c</sup>	Normal at birth Lethal by 4 weeks
<b>Methylation pattern</b>				
IG-DMR	Differential	Methylated	Methylated <sup>d</sup>	Differential
<i>Gtl2</i> -DMR	Differential	Methylated	Epimutated <sup>e</sup>	Methylated <sup>d</sup>
<b>Expression pattern</b>				
<i>Pegs</i>	Monoallelic	Increased (~2x)	Biparental Increased (2x or 4.5x) <sup>f</sup>	Grossly normal
<i>Megs</i>	Monoallelic	Absent	Absent	Decreased (<0.2~0.5x) <sup>g</sup>
<b>&lt;Placenta&gt;</b>				
Phenotype	Normal	Placentomegaly	Apparently normal	Not determined
<b>Methylation pattern</b>				
IG-DMR	Differential	Methylated	Not determined	Not determined
<i>Gtl2</i> -DMR	Non-DMR	Non-DMR	Not determined	Not determined
<b>Expression pattern</b>				
<i>Pegs</i>	Monoallelic	Not determined	Increased (1.5~1.8x) <sup>g</sup>	Decreased (0.5~0.85x) <sup>g</sup>
<i>Megs</i>	Monoallelic	Not determined	Decreased (0.6~0.8x) <sup>g</sup>	Decreased (<0.1~1.0) <sup>g</sup>
Remark			Paternal transmission <sup>h</sup>	Paternal transmission <sup>i</sup> Biparental transmission <sup>j</sup>

<sup>a</sup> The deletion size is smaller than that of patients 1 and 2 in this study, especially at the centromeric region. Thus, it might be possible that a *cis*-acting regulatory element for *DLK1* expression exists in a region that is deleted in patients 1 and 2 and is preserved in the  $\Delta$ IG-DMR mice.

<sup>b</sup> The microdeletion also involves *Gtl2*; in addition, the deletion size is larger than that of patient 3 in this study, so that some essential element(s) might have been deleted or disrupted in the  $\Delta$ *Gtl2*-DMR mouse, but not in patient 3.

<sup>c</sup> Body phenotype includes bell-shaped thorax with rib anomalies, distended abdomen, and short and broad neck.

<sup>d</sup> Hemizyosity for the methylated DMR of paternal origin.

<sup>e</sup> Hypermethylation of the maternally derived DMR.

<sup>f</sup> 2x *Dlk1* and *Dio3* expression levels and 4.5x *Rtl1* expression level. The markedly elevated *Rtl1* expression level is ascribed to a synergic effect between activation of the usually silent *Rtl1* of maternal origin and loss of functional microRNA-containing *Rtl1as* as a repressor for *Rtl1* [21,23–25].

<sup>g</sup> The expression level is variable among examined tissues and examined genes.

<sup>h</sup> The  $\Delta$ IG-DMR of paternal origin has permitted normal *Gtl2*-DMR methylation pattern, intact imprinting status, and normal phenotype in the body (no data on the placenta).

<sup>i</sup> The  $\Delta$ *Gtl2*-DMR of paternal origin is accompanied by normal methylation pattern of the IG-DMR and variably reduced *Pegs* expression and increased *Megs* expression in the body, and has yielded severe growth retardation accompanied by perinatal lethality.

<sup>j</sup> The homozygous mutants have survived and developed into fertile adults, despite rather altered expression patterns of the imprinted genes.

Patient 1

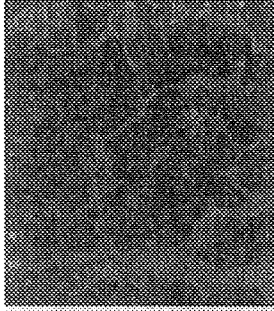
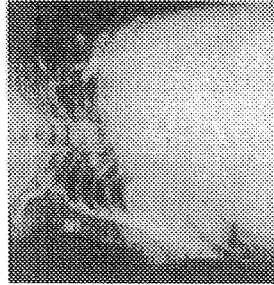

Patient 3

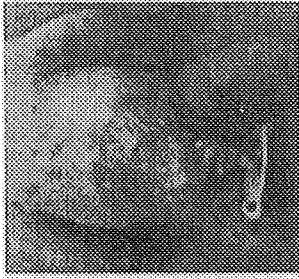
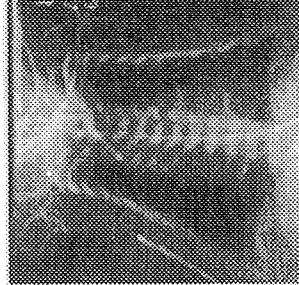

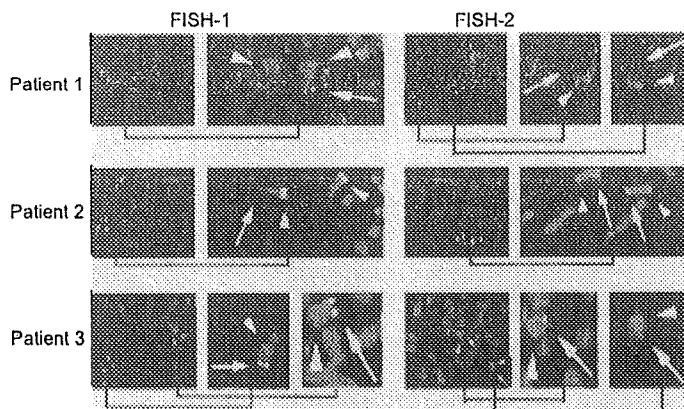
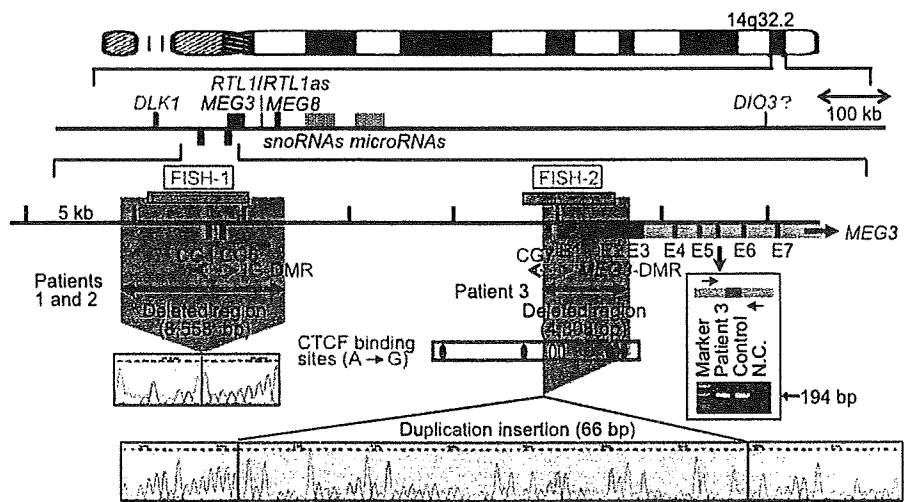

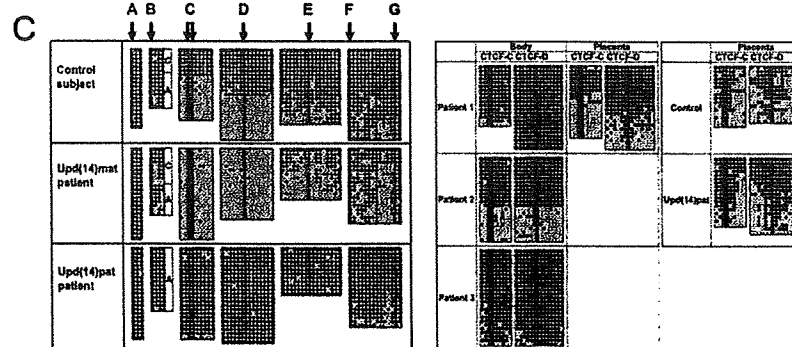
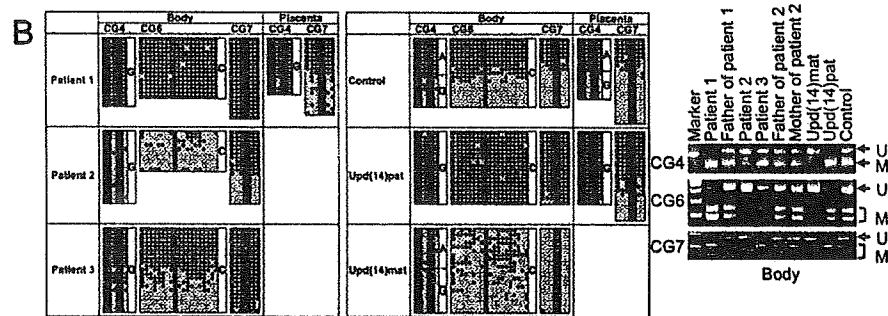
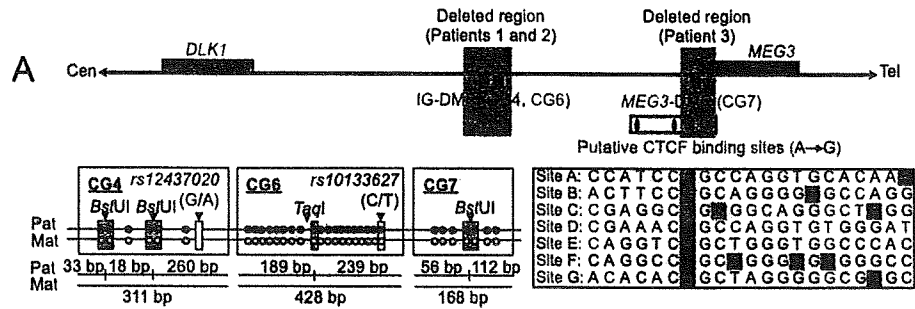



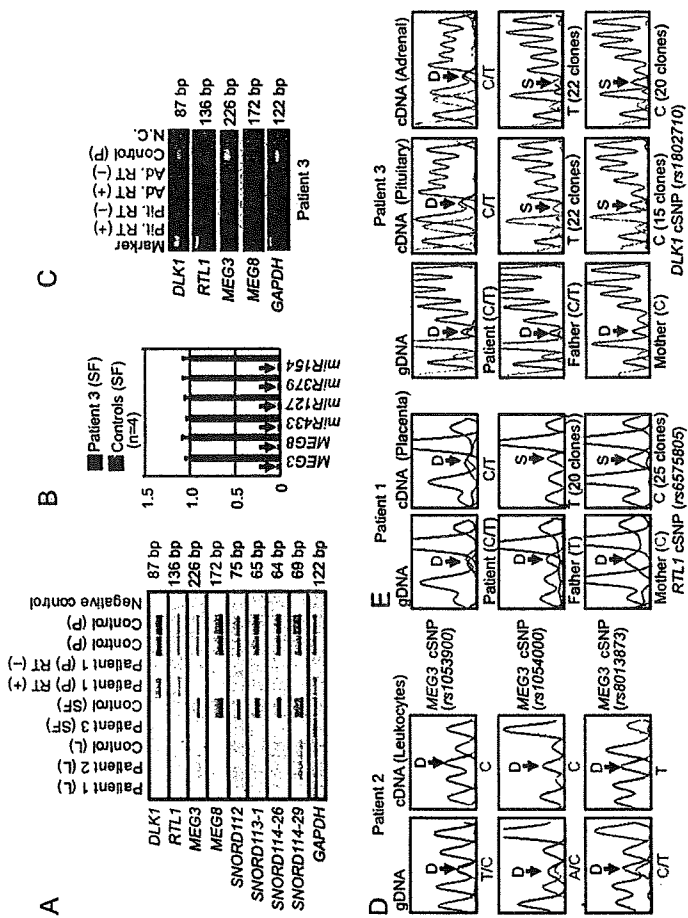

**A**

**B**

**C**

**D**

**E**

