

- 30 Pasquinelli C, Shoenberger JM, Chung J *et al.* Hepatitis C virus core and E2 protein expression in transgenic mice. *Hepatology* 1997; 25: 719–27.
- 31 Koike K, Moriya K, Ishibashi K *et al.* Expression of hepatitis C virus envelope proteins in transgenic mice. *J Gen Virol* 1995; 76: 3031–8.
- 32 Koike K, Moriya K, Yotsuyanagi H *et al.* Sialadenitis resembling Sjögren's syndrome in mice transgenic for hepatitis C virus envelope genes. *Proc Natl Acad Sci USA* 1997; 94: 233–6.
- 33 Lerat H, Honda M, Beard MR *et al.* Steatosis and liver cancer in transgenic mice expressing the structural and nonstructural proteins of hepatitis C virus. *Gastroenterology* 2002; 122: 352–65.
- 34 Naas T, Ghorbani M, Alvarez-Maya I *et al.* Characterization of liver histopathology in a transgenic mouse model expressing genotype 1a hepatitis C virus core and envelope proteins 1 and 2. *J Gen Virol* 2005; 86: 2185–96.
- 35 Kamegaya Y, Hiasa Y, Zukerberg L *et al.* Hepatitis C virus acts as a tumor accelerator by blocking apoptosis in a mouse model of hepatocarcinogenesis. *Hepatology* 2005; 41: 660–7.
- 36 Kawamura T, Furusaka A, Koziel MJ *et al.* Transgenic expression of hepatitis C virus structural proteins in the mouse. *Hepatology* 25: 1014–21.
- 37 Honda A, Arai Y, Hirota N *et al.* Hepatitis C virus structural proteins induce liver cell injury in transgenic mice. *J Med Virol* 1999; 59: 281–9.
- 38 Alonzi T, Agrati C, Costabile B *et al.* Steatosis and intrahepatic lymphocyte recruitment in hepatitis C virus transgenic mice. *J Gen Virol* 2004; 85: 1509–20.
- 39 Frelin L, Brenndörfer ED, Ahlén G *et al.* The hepatitis C virus and immune evasion: non-structural 3/4A transgenic mice are resistant to lethal tumour necrosis factor alpha mediated liver disease. *Gut* 2006; 55: 1475–83.
- 40 Majumder M, Ghosh AK, Steele R *et al.* Hepatitis C virus NS5A protein impairs TNF-mediated hepatic apoptosis, but not by an anti-FAS antibody, in transgenic mice. *Virology* 2002; 294: 94–105.
- 41 Wakita T, Taya C, Katsume A *et al.* Efficient conditional transgene expression in hepatitis C virus cDNA transgenic mice mediated by the Cre/loxP system. *J Biol Chem* 1998; 273: 9001–6.
- 42 Koike K. Molecular basis of hepatitis C virus-associated hepatocarcinogenesis: lessons from animal model studies. *Clin Gastroenterol Hepatol* 2005; 3: S132–5.
- 43 Bach N, Thung SN, Schaffner F. The histological features of chronic hepatitis C and autoimmune chronic hepatitis: a comparative analysis. *Hepatology* 1992; 15: 572–7.
- 44 Moriya K, Nakagawa K, Santa T *et al.* Oxidative stress in the absence of inflammation in a mouse model for hepatitis C virus-associated hepatocellular carcinogenesis. *Cancer Res* 2001; 61: 4365–70.
- 45 Moriya K, Todoroki T, Tsutsumi T *et al.* Increase in the concentration of carbon 18 monounsaturated fatty acids in the liver with hepatitis C: analysis in transgenic mice and humans. *Biophys Biochem Res Commun* 2001; 281: 1207–12.
- 46 Korenaga M, Wang T, Li Y *et al.* Hepatitis C virus core protein inhibits mitochondrial electron transport and increases reactive oxygen species (ROS) production. *J Biol Chem* 2005; 280: 37481–8.
- 47 Powell EE, Jonsson JR, Clouston AD. Steatosis: co-factor in other liver diseases. *Hepatology* 2005; 42: 5–13.
- 48 Perlemuter G, Sabile A, Letteron P *et al.* Hepatitis C virus core protein inhibits microsomal triglyceride transfer protein activity and very low density lipoprotein secretion: a model of viral-related steatosis. *FASEB J* 2002; 16: 185–94.
- 49 Kim KH, Hong SP, Kim K, Park MJ, Kim KJ, Cheong J. HCV core protein induces hepatic lipid accumulation by activating SREBP1 and PPARgamma. *Biochem Biophys Res Commun* 2007; 355: 883–8.
- 50 Waris G, Felmlee DJ, Negro F, Siddiqui A. Hepatitis C virus induces proteolytic cleavage of sterol regulatory element binding proteins and stimulates their phosphorylation via oxidative stress. *J Virol* 2007; 81: 8122–30.
- 51 Su AI, Pezacki JP, Wodicka L *et al.* Genomic analysis of the host response to hepatitis C virus infection. *Proc Natl Acad Sci USA* 2002; 99: 15669–74.
- 52 McPherson S, Jonsson JR, Barrie HD, O'Rourke P, Clouston AD, Powell EE. Investigation of the role of SREBP-1c in the pathogenesis of HCV-related steatosis. *J Hepatol* 2008; 49: 1046–54.
- 53 Bigger CB, Guerra B, Brasky KM *et al.* Intrahepatic gene expression during chronic hepatitis C virus infection in chimpanzees. *J Virol* 2004; 78: 13779–92.
- 54 Koike K, Moriya K, Kimura S. Role of hepatitis C virus in the development of hepatocellular carcinoma: transgenic approach to viral hepatocarcinogenesis. *J Gastroenterol Hepatol* 2002; 17: 394–400.
- 55 Watashi K, Hijikata M, Tagawa A, Doi T, Marusawa H, Shimotohno K. Modulation of retinoid signaling by a cytoplasmic viral protein via sequestration of Sp110b, a potent transcriptional corepressor of retinoic acid receptor, from the nucleus. *Mol Cell Biol* 2003; 23: 7498–509.
- 56 Moriya K, Shintani Y, Fujie H *et al.* Serum lipid profile of patients with genotype 1b hepatitis C viral infection in Japan. *Hepatol Res* 2003; 25: 371–6.
- 57 Miyanari Y, Atsuzawa K, Usuda N *et al.* The lipid droplet is an important organelle for hepatitis C virus production. *Nat Cell Biol* 2007; 9: 1089–97.
- 58 Kapadia SB, Chisari FV. Hepatitis C virus RNA replication is regulated by host geranylgeranylation and fatty acids. *Proc Natl Acad Sci USA* 2005; 102: 2561–6.
- 59 Tsutsumi T, Suzuki T, Shimoike T *et al.* Interaction of hepatitis C virus core protein with retinoid X receptor- α modulates its transcriptional activity. *Hepatology* 2002; 35: 937–46.

- 60 Peters JM, Cheung C, Gonzalez FJ. Peroxisome proliferator-activated receptor-alpha and liver cancer: where do we stand? *J Mol Med* 2005; 83: 774–85.
- 61 Li Y, Boehning DF, Qian T, Popov VL, Weinman SA. Hepatitis C virus core protein increases mitochondrial ROS production by stimulation of Ca²⁺ uniporter activity. *FASEB J* 2007; 21: 2474–85.
- 62 Kinzler KW, Vogelstein B. Lessons from hereditary colorectal cancer. *Cell* 1996; 87: 159–70.

Efficient production of infectious hepatitis C virus with adaptive mutations in cultured hepatoma cells

Yasuaki Bungyoku, Ikuo Shoji, Tatsuhiko Makine, Tetsuya Adachi, Kazumi Hayashida, Motoko Nagano-Fujii, Yoshi-Hiro Ide, Lin Deng and Hak Hotta

Correspondence

Hak Hotta

hotta@med.kobe-u.ac.jp

Division of Microbiology, Kobe University Graduate School of Medicine, 7-5-1 Kusunoki-cho, Chuo-ku, Kobe, Hyogo 650-0017, Japan

Robust production of infectious hepatitis C virus (HCV) in cell culture was realized by using the JFH1 strain and the homologous chimeric J6/JFH1 strain in Huh-7.5 cells, a highly HCV-permissive subclone of Huh-7 cells. In this study, we aimed to establish a more efficient HCV-production system and to gain some insight into the adaptation mechanisms of efficient HCV production. By serial passaging of J6/JFH1-infected Huh-7.5 cells, we obtained culture-adapted J6/JFH1 variants, designated P-27, P-38 and P-47. Sequence analyses revealed that the adaptive mutant viruses P-27, P-38 and P-47 possessed eight mutations [four in E2, two in NS2, one in NS5A and one in NS5B], 10 mutations [two additional mutations in the 5'-untranslated region (5'-UTR) and core] and 11 mutations (three additional mutations in 5'-UTR, core and NS5B), respectively. We introduced amino acid substitutions into the wild-type J6/JFH1 clone, generated recombinant viruses with adaptive mutations and analysed their infectivity and ability to produce infectious viruses. The viruses with the adaptive mutations exhibited higher expression of HCV proteins than did the wild type in Huh-7.5 cells. Moreover, we provide evidence suggesting that the mutation N534H in the E2 glycoprotein of the mutant viruses conferred an advantage at the entry level. We thus demonstrate that an efficient HCV-production system could be obtained by introducing adaptive mutations into the J6/JFH1 genome. The J6/JFH1-derived mutant viruses presented here would be a good tool for producing HCV particles with enhanced infectivity and for studying the molecular mechanism of HCV entry.

Received 11 February 2009

Accepted 5 March 2009

INTRODUCTION

Hepatitis C virus (HCV) is the main cause of chronic hepatitis, liver cirrhosis and hepatocellular carcinoma (Choo *et al.*, 1989; Kuo *et al.*, 1989; Saito *et al.*, 1990). As more than 170 million people worldwide are infected chronically with HCV (Poynard *et al.*, 2003) and because the current antiviral therapy, interferon and ribavirin, produces sustained virus clearance in <50% of treated patients (Manns *et al.*, 2007), HCV infection is clearly a problem of major proportions. HCV is a single-stranded, positive-sense RNA virus that is classified in the genus *Hepacivirus* in the family *Flaviviridae*. The approximately 9.6 kb HCV genome encodes one large open reading frame (ORF) that is flanked at the 5' and 3' ends by untranslated regions (UTRs) (Choo *et al.*, 1991). The HCV polyprotein is processed into at least 10 proteins by viral proteases and cellular signalases (Grakoui *et al.*, 1993; Hijikata *et al.*, 1993a; McLauchlan *et al.*, 2002). The structural proteins core, E1 and E2 are located in the N terminus of the polyprotein, followed by p7 and the non-structural (NS) proteins NS2, NS3, NS4A, NS4B, NS5A and NS5B (Bartenschlager & Sparacio, 2007).

Study of the HCV life cycle and virus–host interaction has been hampered severely by the lack of a robust *in vitro* cell-culture system and small-animal models of HCV infection (Bartenschlager & Sparacio, 2007). The development of HCV replicon systems has made an important contribution to the study of HCV translation and RNA replication in the human hepatoma cell line Huh-7 (Blight *et al.*, 2000; Lohmann *et al.*, 1999). Sequence analyses of multiple HCV replicons have revealed that several adaptive mutations enhance RNA replication to varying degrees (Bartenschlager & Sparacio, 2007; Blight *et al.*, 2000; Lohmann *et al.*, 2001). Such adaptive mutations were primarily identified in a central portion of the NS5A protein. Although the extent to which these adaptive mutations enhance RNA replication was subsequently studied by using various transient replication assays, the molecular mechanism underlying replication enhancement still remains elusive (Bartenschlager & Sparacio, 2007). The HCV replicons containing adaptive mutations do not produce infectious virus particles in culture and are severely attenuated (Blight *et al.*, 2002; Pietschmann *et al.*, 2002). Using recombinant HCV envelope glycoproteins

and HCV pseudoparticles, several cell-surface molecules have been shown to interact with HCV during virus binding and entry, including the tetraspanin CD81 (Bartosch *et al.*, 2003; Pileri *et al.*, 1998), the scavenger receptor class B member I (SR-BI) (Bartosch *et al.*, 2003; Scarselli *et al.*, 2002) and the tight junction protein claudin-1 (CLDN1) (Evans *et al.*, 2007).

The major breakthrough was made by establishing an HCV-production system using HCV strain JFH1, a genotype 2a isolate, and Huh-7 cells (Wakita *et al.*, 2005). Two other groups reported a robust production of infectious virus using a homologous chimeric FL-J6/JFH1 strain (Lindenbach *et al.*, 2005) or using Huh-7.5.1 cells (Zhong *et al.*, 2005) derived from the cell line Huh-7.5, which has a defect in the RIG-I pathway (Sumpster *et al.*, 2005). Upon transfection of Huh-7 cells with the *in vitro*-transcribed HCV JFH1 genome or the chimera FL-J6/JFH1, infectious HCV particles were secreted in an envelope glycoprotein-dependent manner (Lindenbach *et al.*, 2005; Wakita *et al.*, 2005; Zhong *et al.*, 2005). Using HCV-production systems, adaptive or compensatory mutations that promote the production of infectious virus from wild-type JFH1 (Delgrange *et al.*, 2007; Kaul *et al.*, 2007; Russell *et al.*, 2008; Zhong *et al.*, 2006) or chimeric viruses (Gottwein *et al.*, 2007; Yi *et al.*, 2006, 2007) have been identified. However, the molecular mechanisms of adaptive mutations are poorly understood.

In this study, we aimed to establish an efficient HCV-production system and to gain more insight into the determinants of efficient virus production. By serial passaging of Huh-7.5 cells infected with the HCV J6/JFH1 strain, we identified adaptive mutations in the clones and analysed the mutations by examining the production of the recombinant mutant viruses.

METHODS

Cell culture. Huh-7.5 cells (Blight *et al.*, 2002), a highly HCV-permissive subclone of Huh-7 cells, were kindly provided by Dr C. M. Rice (Rockefeller University, New York, NY, USA). Cells were cultured in Dulbecco's modified Eagle's medium (DMEM; Wako) supplemented with 10% fetal bovine serum (FBS; Biowest), 0.1 mM non-essential amino acids (Invitrogen), 100 IU penicillin ml⁻¹ and 100 µg streptomycin ml⁻¹ (Invitrogen). DMEM containing 10% FBS was designated complete DMEM. Cells were grown at 37 °C in a CO₂ incubator.

Antibodies. The mouse monoclonal antibodies (mAbs) used in this study were anti-core (2H9) mAb (Wakita *et al.*, 2005) and anti-HCV NS3 mAb (Chemicon). Goat anti-actin polyclonal antibody (C-11) (Santa Cruz Biotech) was used. Horseradish peroxidase (HRP)-conjugated goat anti-mouse IgG (MBL) and HRP-conjugated donkey anti-goat IgG (Santa Cruz Biotech) were used as secondary antibodies.

Plasmids. Plasmid pFL-J6/JFH1 (Lindenbach *et al.*, 2005) containing the full-length chimeric HCV genome was used to generate infectious HCV. Amino acid substitutions were introduced by site-directed mutagenesis using a QuikChange site-directed mutagenesis kit

(Stratagene). All PCR-amplified DNA fragments were verified extensively by using an ABI PRISM 3100-Avant Genetic Analyzer (Applied Biosystems). The primer sequences used in this study are available from the authors upon request.

HCV RNA transfection and virus production. The pFL-J6/JFH1 plasmid was linearized with *Xba*I and *in vitro*-transcribed by using the T7 RiboMAX Express large-scale RNA production system (Promega) following the manufacturer's instructions. The quality of synthesized RNA was examined by agarose gel electrophoresis. Cells were trypsinized and washed with serum-free DMEM. In total, 6 × 10⁶ cells were suspended in 500 µl serum-free DMEM and mixed with 10 µg *in vitro*-transcribed RNA in a 4 mm cuvette (Bio-Rad). The synthesized RNA was introduced into Huh-7.5 cells by electroporation using a Bio-Rad Gene Pulser system with a single pulse at 270 V, 975 µF. The cells were then plated in 10 cm culture dishes containing complete DMEM.

Indirect immunofluorescence. Immunofluorescence staining was performed essentially as described previously (Takigawa *et al.*, 2004). Cells seeded on glass coverslips in a 24-well plate at a density of 4 × 10⁴ cells per well were infected with HCV. Cells were cultured, washed with PBS and fixed with 3.7% paraformaldehyde in PBS for 10 min at room temperature, followed by permeabilization in 0.1% Triton X-100 in PBS for 10 min at room temperature. After being washed twice with PBS, cells were blocked with 5% goat serum in PBS and then incubated with the serum of an HCV-infected patient with a high titre of anti-HCV antibodies. Fluorescein isothiocyanate-conjugated goat anti-human IgG (MBL) was used as a secondary antibody. The cells were washed with PBS, counterstained with Hoechst 33342 solution (Molecular Probes) at room temperature for 10 min, mounted on glass slides and examined under a fluorescence microscope (BX51; Olympus).

Virus titration. Culture supernatants were diluted serially 10-fold in complete DMEM and used to infect 2 × 10⁵ naïve Huh-7.5 cells per well in 24-well plates. The inoculum was incubated with cells for 6 h at 37 °C and then supplemented with fresh complete DMEM. The level of HCV infection was determined 1 day post-infection by immunofluorescence using anti-HCV polyclonal antibody. The virus titre was expressed in focus-forming units (ml supernatant)⁻¹ (f.f.u. ml⁻¹), as determined by the mean number of HCV-positive foci detected at the highest dilutions according to a previously described method (Zhong *et al.*, 2005).

Immunoblotting. Immunoblotting was performed essentially as described previously (Muramatsu *et al.*, 1997). To detect the expression of HCV proteins, the immune complexes were visualized by an ECL Western blotting detection kit (GE Healthcare) following the manufacturer's instructions.

HCV RNA quantification. Total RNA was extracted by using RNeasy (Qiagen) according to the manufacturer's instructions. One microgram of isolated RNA was reverse-transcribed by using a QuantiTect reverse transcription kit (Qiagen) with random primers. RT-qPCR analysis was performed as described previously (Zhong *et al.*, 2005). HCV RNA was monitored by using the PCR primers 5'-TCTGCGGAACCGGTGAGTA-3' (sense) and 5'-TCAGGCAGTACCACAAGGC-3' (antisense). HCV transcript levels were determined relative to a standard curve comprising serial dilutions of plasmid containing the HCV J6/JFH1 cDNA.

HCV RNA genome sequencing. HCV RNA was isolated from 140 µl viral supernatant by using a QIAamp Viral RNA Mini kit (Qiagen), and then used as a template to generate cDNA in a reverse-transcription reaction using SuperScript One-Step RT-PCR with Platinum *Taq* (Invitrogen) according to the manufacturer's instruc-

tions. PCR primers of between 20 and 26 bases, designed using the sequence of J6/JFH1, were used to amplify four fragments of HCV cDNA (nt 49–3517, 2582–5966, 5832–8038 and 7870–9286) to cover most of the HCV genome. In addition, the 5'-end sequence was amplified by using the 5' RACE System for Rapid Amplification of cDNA Ends (Invitrogen) and the 3'-end sequence was amplified by using a 3'-Full RACE Core set (TaKaRa). The sequences of the amplified DNA were determined by using an ABI PRISM 3100-Avant Genetic Analyzer.

Quantification of HCV core protein. HCV core protein in the cells or cell-culture supernatants was quantified by using a highly sensitive enzyme immunoassay (Ortho HCV antigen ELISA kit; Ortho Clinical Diagnostics). To determine intracellular amounts of core, cell lysates were prepared as described by Schaller *et al.* (2007).

Blocking of virus attachment and entry with anti-CD81 antibody. Blocking of virus attachment and entry with anti-CD81 antibody was performed essentially as described previously (Wakita *et al.*, 2005). Huh-7.5 cells (6×10^4 cells per 24-well plate) were pretreated with anti-CD81 antibody (clone JS-81; BD Biosciences) or an isotype-matched control antibody (purified mouse IgG1, κ isotype control; BD Biosciences) as indicated for 1 h. Cells were then infected with the wild-type or mutant viruses at an m.o.i. of 0.5 or 0.01 for 6 h. The viruses were removed, and the cells were washed with PBS and then supplemented with complete DMEM. The efficiency of infection was monitored 1 day after infection by counting the number of HCV-positive foci by immunofluorescence.

Statistical analysis. A two-tailed Student's *t*-test was applied to evaluate the statistical significance of differences measured from the datasets. A *P* value of <0.05 was considered to be statistically significant.

RESULTS

Increase in HCV infectivity titres during serial passage

To produce infectious HCV particles, *in vitro*-transcribed genomic J6/JFH1 RNA was electroporated into Huh-7.5 cells. Transfected Huh-7.5 cells were maintained and the infectivity titre of the culture supernatant reached 6×10^4 f.f.u. ml⁻¹ at 20 days post-infection. This culture supernatant was designated P-1.

To generate higher infectivity titres for HCV, naïve Huh-7.5 cells (3×10^5 cells per six-well plate) were infected with 1 ml virus stock of P-1 (6×10^4 f.f.u. ml⁻¹) at an m.o.i. of 0.2 and the infected cells were passaged serially every 3–4 days to maintain a subconfluent culture for 6 months. The culture medium was replaced with fresh complete DMEM every day. The extracellular infectivity titres fluctuated in the beginning after transfection and became lowest at the 22nd passage (Fig. 1a). Thereafter, the extracellular infectivity titres increased again and reached highest infectivity at the 47th passage. Therefore, we further examined the supernatants at the 27th, 38th and 47th passages, and the viruses were designated P-27, P-38 and P-47, respectively. The infectivity titres were determined to be 7.0×10^3 f.f.u. ml⁻¹ for P-27, 1.7×10^4 f.f.u. ml⁻¹ for P-38 and 3.3×10^4 f.f.u. ml⁻¹ for P-47 (Fig. 1a). These viruses were used as inocula in the following experiments.

Kinetics of virus production after infection with putative adaptive J6/JFH1 mutants

To examine the virus-production kinetics of these viruses in Huh-7.5 cells, naïve Huh-7.5 cells (3×10^4 cells per 24-well plate) were infected with each inoculum (6×10^3 f.f.u.) at an m.o.i. of 0.2. After infection, the culture supernatants were harvested each day for 10 days and assayed for infectivity titres (Fig. 1b). The P-1 virus showed a peak infectivity titre of 2.3×10^4 f.f.u. ml⁻¹ at 4 days post-infection, whereas the P-27, P-38 and P-47 viruses showed peak titres of 1.0×10^6 , 2.3×10^6 and 6.0×10^6 f.f.u. ml⁻¹ at 4–5 days post-infection, respectively (Fig. 1b), suggesting that these three viruses produce infectious HCV particles more efficiently than the P-1 virus. The increased infectivity titres may have been due to an increase in the absolute number of released HCV particles or an increased proportion of infectious relative to non-infectious particles. To address this question, we compared the specific infectivities of the mutant viruses with those of the wild-type virus. The ratio of viral infectivity titre (f.f.u. ml⁻¹) to HCV RNA content [genome equivalents (GE) ml⁻¹] was determined as shown in Table 1. The mutant viruses, P-27, P-38 and P-47, had higher specific-infectivity titres (1:21, 1:10 and 1:10, respectively) than the wild-type virus P-1 (1:133), suggesting that the mutant viruses are more infectious than the wild type and that the mutant viruses possess adaptive mutations in the virus genomes.

Sequence analysis of genetic mutations in the adaptive mutants

To identify the genetic changes in the virus genomes that are responsible for the adaptation to Huh-7.5 cells, we sequenced the whole genomes of the viruses. No mutation was found in the P-1 virus, whereas several mutations were identified in the P-27, P-38 and P-47 viruses (Fig. 1c). The sequencing analysis of P-27 identified eight mutations that were located in the E2, NS2, NS5A and NS5B regions as follows: T396A, T416A, N534H and A712V in E2; Y852H and W879R in NS2; F2281L in NS5A; and M2876L in NS5B (Fig. 1c). P-38 possessed 10 mutations, the same mutations as in P-27 and two additional mutations. The additional mutations were found at nucleotide position 146 (U to A) in the 5'-UTR and an amino acid change, K78E, in the core region. P-47 contained 11 mutations, including the same 10 mutations as P-38 and one additional mutation, T2925A in NS5B. Thus, the first eight mutations were all present in the genomes of the three viruses, and the results suggested that these eight mutations contribute to the enhanced infectivity.

Effects of individual mutations on the production of infectious HCV

To determine which mutation is responsible for the enhancement of infectivity, recombinant genomes containing only one of the selected mutations were constructed

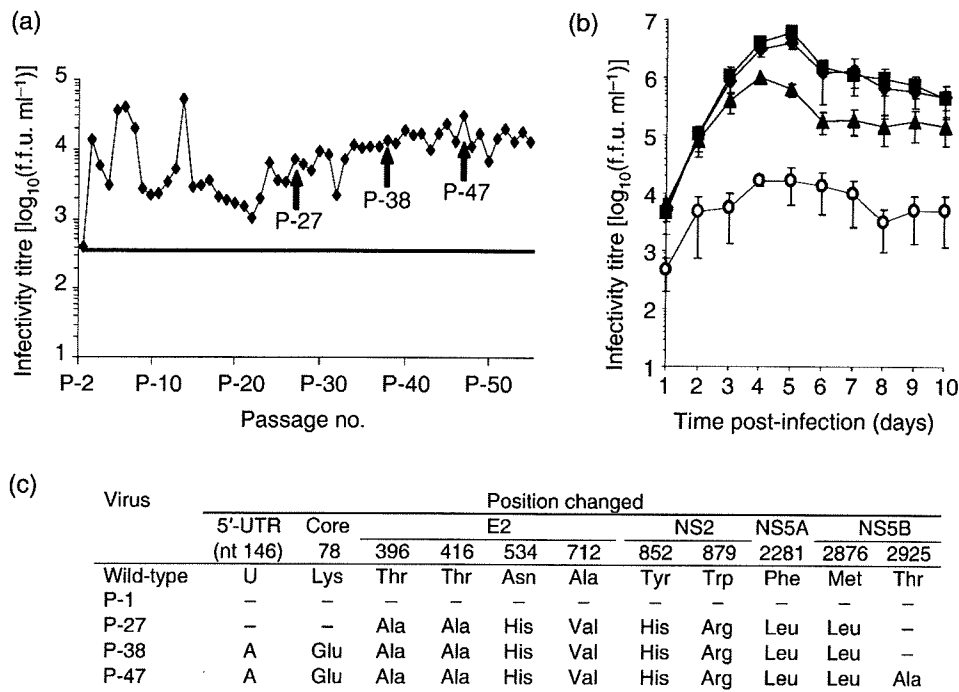

Fig. 1. Increase in HCV infectivity titres during serial passage. (a) Serial passage of HCV J6/JFH1-infected Huh-7.5 cells. Huh-7.5 cells (3×10^5 cells per six-well plate) were infected with 1 ml stock of wild-type J6/JFH1 virus (P-1) (6×10^4 f.f.u. ml^{-1}) at an m.o.i. of 0.2, and the infected cells were passaged serially every 3–4 days to maintain a subconfluent culture for 6 months. The culture medium was replaced with fresh complete DMEM each day. The extracellular infectivity titres were determined by titration assay and are expressed as f.f.u. ml^{-1} . Arrows show the time points at which we collected the putative adapted viruses, designated P-27, P-38 and P-47. (b) Kinetics of virus production after infection with putative J6/JFH1 adaptive mutants in Huh-7.5 cells. Huh-7.5 cells were infected with the wild-type J6/JFH1 virus (○, P-1) or putative adaptive mutants (▲, P-27; ◆, P-38; ■, P-47) at an m.o.i. of 0.2. After infection, the culture supernatants were harvested every day until 10 days post-infection. Infectivity titres were measured by immunofluorescence assay and are expressed as f.f.u. ml^{-1} . Error bars represent SD for triplicate measurements. (c) Genetic mutations identified during passage. Numbers indicate the amino acid position where mutations were identified. The nucleotide position with mutation is given in parentheses.

(Fig. 2a). The *in vitro*-transcribed mutant J6/JFH1 RNAs were electroporated into Huh-7.5 cells and mutant viruses were generated. Then, naïve Huh-7.5 cells were infected with each virus at an m.o.i. of 0.01 and cultured for 12 days. The culture supernatant was collected every day from 1 to 12 days post-infection. The ability of each mutant virus to release infectious virus particles was examined by titration assay. As shown in Fig. 2(b), the

recombinant viruses with single point mutations did not enhance the production of infectious virus particles, suggesting that a single point mutation is not enough for the enhanced infectivity.

Effects of combination of adaptive mutations on the production of infectious HCV

We then generated recombinant viruses with several mutations, as shown in Fig. 3(a). Naïve Huh-7.5 cells were infected with each virus at an m.o.i. of 0.01 and cultured for 12 days. The culture supernatant was collected every day from 1 to 12 days post-infection. The ability of each mutant virus to release infectious virus particles was examined by titration assay. The R-27, R-38 and R-47 viruses reached higher titres than the wild type and other mutant viruses, suggesting that all of the mutations in E2, NS2, NS5A and NS5B were important for the enhancement of infectivity (Fig. 3b). To determine the specific infectivities of the mutant viruses, the ratio of the viral infectivity titre (f.f.u. ml^{-1}) to the HCV RNA content (GE

Table 1. Specific-infectivity titres of the adaptive J6/JFH1 mutant viruses

Virus	HCV RNA copies [$\log_{10}(\text{GE ml}^{-1})$]	Infectivity titre [$\log_{10}(\text{f.f.u. ml}^{-1})$]	Specific infectivity (f.f.u. : GE)
P-1	6.7 ± 0.1	4.6 ± 0.1	1 : 133
P-27	7.3 ± 0.1	6.0 ± 0.2	1 : 21
P-38	7.4 ± 0.1	6.4 ± 0.0	1 : 10
P-47	7.3 ± 0.1	6.3 ± 0.2	1 : 10

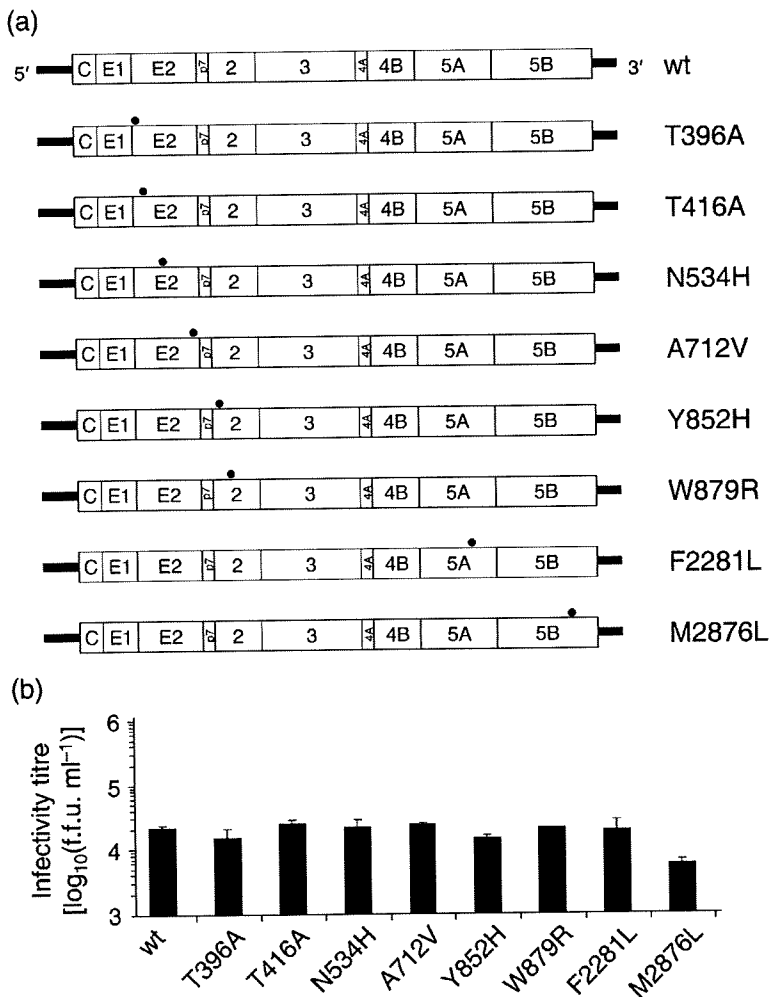

Fig. 2. Effects of individual mutations on the production of infectious HCV. (a) Schematic representation of the wild-type (wt) and mutant chimeric HCV J6/JFH1 genomes. HCV J6/JFH1 mutants with a single point mutation are shown. The adaptive mutations T396A, T416A, N534H, A712V, Y852H, W879R, F2281L and M2876L are indicated by ●. (b) The *in vitro*-transcribed mutant J6/JFH1 RNAs were electroporated into Huh-7.5 cells to generate recombinant mutant viruses. The infectivity titres of the culture supernatants were measured by titration assay. Then, naïve Huh-7.5 cells were infected with each virus at an m.o.i. of 0.01 and cultured for 12 days. The culture supernatant was collected every day from 1 to 12 days post-infection. The ability of each mutant virus to release infectious virus particles was examined by titration assay. Infectivity titres reached maximal levels at 10 days post-infection and the maximal infectivity titres were plotted. Error bars represent SD for triplicate measurements.

ml⁻¹) was calculated as shown in Table 2. The recombinant mutant viruses, R-27, R-38 and R-47, had higher specific-infectivity titres (1:46, 1:35 and 1:54, respectively) than the wild-type virus P-1 (1:197), suggesting that the particles released from cells infected with the R-27, R-38 and R-47 viruses are more infectious than those released from cells infected with the wild-type J6/JFH1 virus.

Efficient expression of HCV proteins in Huh-7.5 cells infected with the adaptive mutants

To investigate further the mechanism of adaptive mutations, we performed immunofluorescence staining of the infected cells. Huh-7.5 cells (6×10^4 cells per 24-well plate) were infected with the P-1, R-27, R-38 and R-47 viruses (1.2×10^4 f.f.u.) at an m.o.i. of 0.2. Cells were fixed 5 days post-infection and stained for immunofluorescence. Approximately 90% of the cells were HCV-positive in the P-1-, R-27-, R-38- and R-47-infected cells (Fig. 4a). We next examined protein synthesis by immunoblotting for the HCV core and NS3 proteins. Immunoblot analysis of

the cell lysates demonstrated that the levels of the core and NS3 proteins in cells infected with the R-27, R-38 and R-47 viruses were 2.0- to 2.5-fold higher than those in cells infected with the P-1 virus (Fig. 4b, c), suggesting that these mutant viruses have a replicative advantage.

Growth curves of infectious HCV after transfection of RNAs or infection with HCV

To determine whether the replicative advantage is at the level of entry or replication/translation of the genome, we examined one-step growth curves by transfecting equivalent amounts of RNAs of the wild-type and the mutant viruses into Huh-7.5 cells by means of electroporation (Fig. 5a, b). The intracellular and extracellular core protein levels were quantified by core protein-specific ELISA at the indicated times. The one-step growth curves showed that the intracellular and extracellular core protein levels increased with very similar kinetics in the cells transfected with the wild-type and adapted RNAs (Fig. 5a, b).

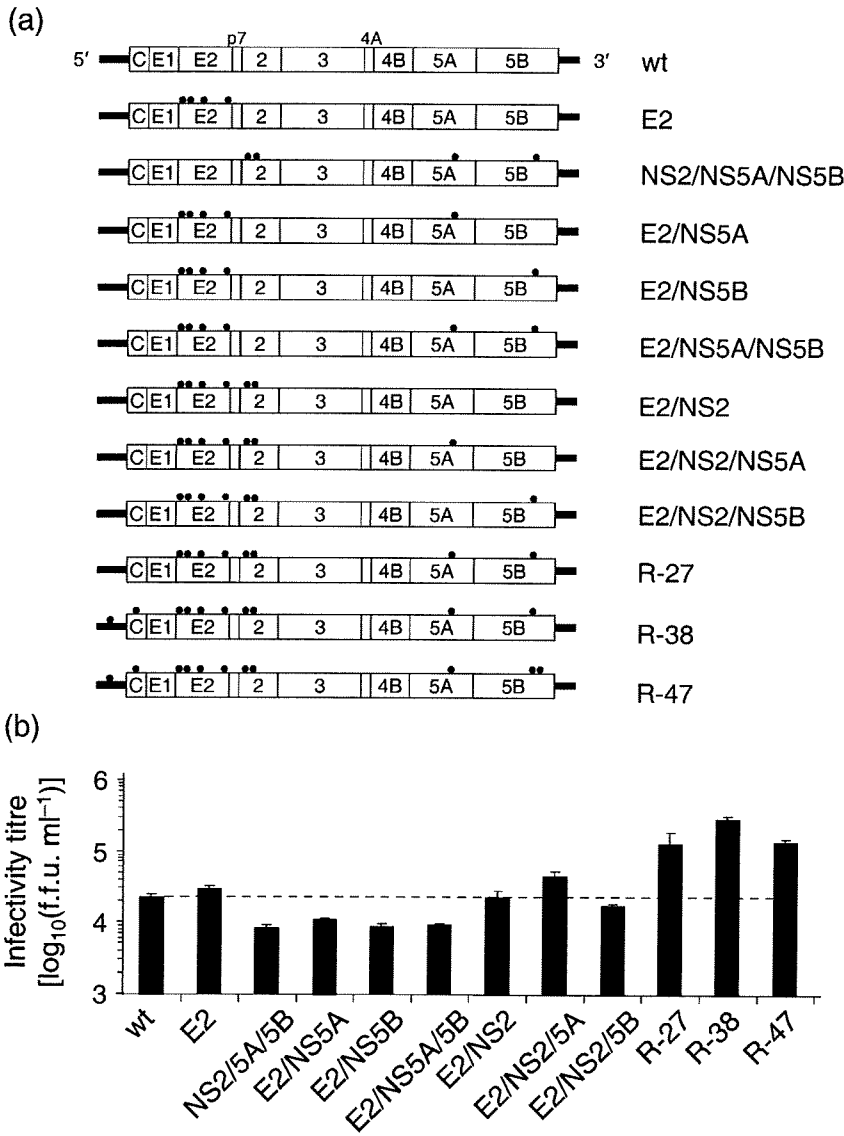

Fig. 3. Effects of combination of adaptive mutations on the production of infectious HCV. (a) Schematic representation of the wild-type (wt) and mutant chimeric HCV J6/JFH1 genomes. The HCV J6/JFH1 genomes with a combination of adaptive mutations at nt 146 (U to A) in the 5'-UTR and amino acid changes at K78E, T396A, T416A, N534H, A712V, Y852H, W879R, F2281L and M2876L are indicated by ●. (b) Recombinant mutant viruses with a combination of mutations were generated. Naïve Huh-7.5 cells were infected with each virus at an m.o.i. of 0.01 and cultured for 12 days. The ability of each mutant to release infectious virus particles was examined by titration assay. Infectivity titres reached maximal levels at 10 or 11 days post-infection and the maximal infectivity titres were plotted. Error bars represent SD for triplicate measurements.

We next examined the growth curves of the core protein levels by infecting cells with the recombinant viruses. The intracellular and extracellular core protein levels in cells infected with the P-1, R-27, R-38 and R-47 viruses were

Table 2. Specific-infectivity titres of the recombinant adaptive mutant viruses

Virus	HCV RNA copies [log ₁₀ (GE ml ⁻¹)]	Infectivity titre [log ₁₀ (f.f.u. ml ⁻¹)]	Specific infectivity (f.f.u.:GE)
P-1	6.6 ± 0.1	4.3 ± 0.1	1:197
R-27	6.8 ± 0.1	5.1 ± 0.2	1:46
R-38	6.9 ± 0	15.4 ± 0.1	1:35
R-47	6.9 ± 0.1	5.1 ± 0.1	1:54

quantified. Huh-7.5 cells (1.2 × 10⁵ cells per 12-well plate) were infected with these viruses at an m.o.i. of 0.2. The intracellular core protein levels in cells infected with the R-27, R-38 and R-47 viruses were 3- to 5-fold higher at day 1 post-infection than those in the P-1-infected cells. The intracellular core protein levels in the cells infected with the mutant viruses were 7- to 11-fold higher at day 3 post-infection than those in the P-1-infected cells (Fig. 5c). The extracellular core protein levels in the P-1-infected cells were comparable to the levels in cells infected with mutant viruses at day 1 post-infection. However, the extracellular core protein levels in cells infected with the R-27, R-38 and R-47 viruses increased more rapidly and reached 4.4- to 5.8-fold higher at day 3 post-infection than those in cells infected with the P-1 virus (Fig. 5d). Taken together, these data suggest that the adaptive mutants have advantages at the entry level, rather than the virus replication/translation level.

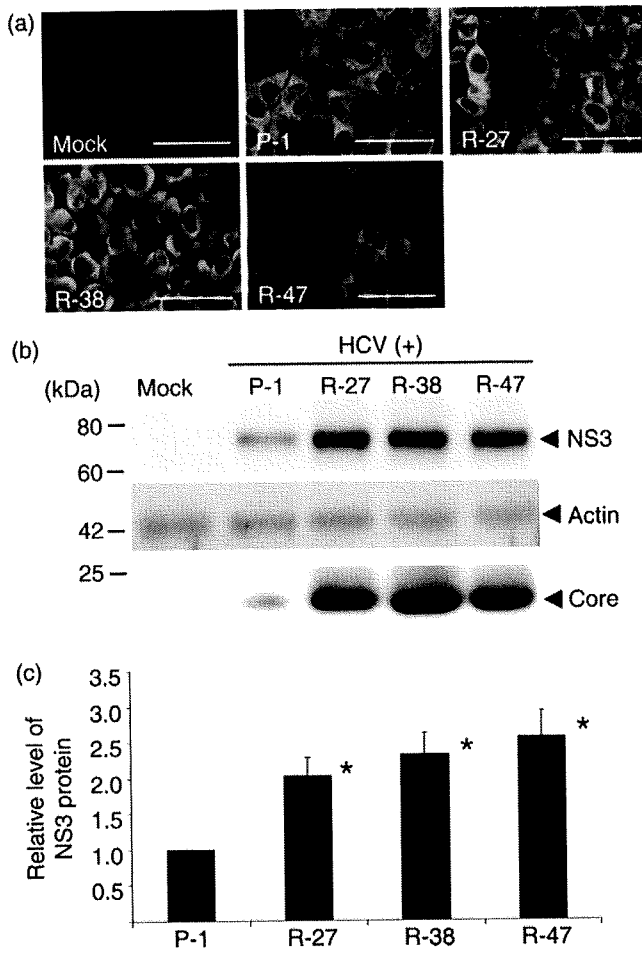

Fig. 4. Efficient expression of HCV proteins in Huh-7.5 cells infected with the adaptive mutants. Huh-7.5 cells (6×10^4 cells per 24-well plate) were infected with 200 μ l P-1, R-27, R-38 or R-47 virus (6×10^4 f.f.u. ml^{-1}) at an m.o.i. of 0.2. (a) Cells were fixed 5 days post-infection and stained for immunofluorescence with anti-HCV-positive sera. Bars, 10 μ m. (b) Immunoblot analysis of core and NS3 proteins in Huh-7.5 cells infected with R-27, R-38 and R-47 viruses. Data are representative of three independent experiments. (c) Quantification of the data shown in (b). Intensities of the gel bands were quantified by using the Scion Image for Windows program. The level of actin served as a loading control. Error bars represent SD for triplicate measurements. The difference between P-1 and the adaptive mutant (R-27, R-38 or R-47) was significant ($*P < 0.05$ by Student's *t*-test).

Blocking of virus attachment and entry with anti-CD81 antibody

To determine whether the adapted mutant viruses have advantages at the entry level, we examined CD81-dependent entry into Huh-7.5 cells. Naïve Huh-7.5 cells were incubated with CD81-specific or non-specific antibody prior to inoculation. We scored infection by immunofluorescence at 24 h post-infection. As shown in Fig. 6(a), the anti-CD81 antibody inhibited the entry of the

mutant viruses R-27, R-38 and R-47, as well as the wild-type virus, in a dose-dependent manner, suggesting that interaction between CD81 and HCV E2 glycoprotein is crucial for virus entry for all of these viruses. However, infections by the mutant viruses R-27, R-38 and R-47 were less dependent on CD81 than the wild-type virus. This result suggests that the mutations in the E2 glycoprotein confer an advantage to the mutant viruses at the entry level. We further analysed the mutant viruses to determine which mutation(s) is important for the advantage at the entry level. We infected Huh-7.5 cells with mutant viruses with a single point mutation in the E2 glycoprotein, such as T396A, T416A, N534H or A712V, or with all of the four mutations in E2. Blocking of virus entry with the anti-CD81 antibody was examined as shown in Fig. 6(b). Infection by the mutant virus N534H, as well as the mutant viruses E2, R-27, R-38 and R-47, was less dependent on CD81 than infection by the wild-type virus, whereas the other mutant viruses T396A, T416A and A712V showed a similar pattern to the wild type. These results indicate that the N534H mutation in the E2 region confers an advantage to the adaptive mutant viruses at the entry level.

DISCUSSION

In this study, we established an efficient HCV-production system by serial passaging of Huh-7.5 cells infected with the chimeric HCV J6/JFH1. Sequence analyses revealed that the adapted viruses possessed more than eight non-synonymous mutations in the genomes. Reverse-genetics analysis revealed that the recombinant viruses R-27, R-38 and R-47 exhibited higher expression of the HCV proteins than the wild-type virus. Moreover, we demonstrated that the N534H mutation in the E2 glycoprotein confers an advantage to the mutant viruses at the entry level.

The adaptive mutant viruses possessed four mutations (T396A, T416A, N534H and A712V) in E2. Two of these mutations (T416A and N534H) are in the regions that are involved in E2-CD81 binding and are, therefore, the possible target for neutralizing antibodies inhibiting E2-CD81 interactions (Helle & Dubuisson, 2008). The blocking of virus attachment and entry with CD81-specific antibody in this study revealed that the infections by the E2 R-27, R-38, R-47 and N534H mutants were less dependent on the CD81 molecule than that by the wild type J6/JFH1, suggesting that the N534H mutation gives the mutant viruses a selective advantage at the entry level. The N534H mutation is located in the sixth of 11 *N*-glycosylation sites, and is predicted to remove this *N*-glycosylation. The removal of *N*-glycosylation sites has been shown to have variable effects on CD81 binding and infectivity (Owsianka *et al.*, 2006; Roccasecca *et al.*, 2003). The glycans at positions 417, 532 and 645 (E2N1, E2N6 and E2N11) were shown to reduce the sensitivity of HCV pseudoparticles to antibody neutralization and to reduce the access of CD81 to its binding site on E2 (Goffard *et al.*, 2005). JFH-1 virus with the N534K mutation spread faster than the wild-type

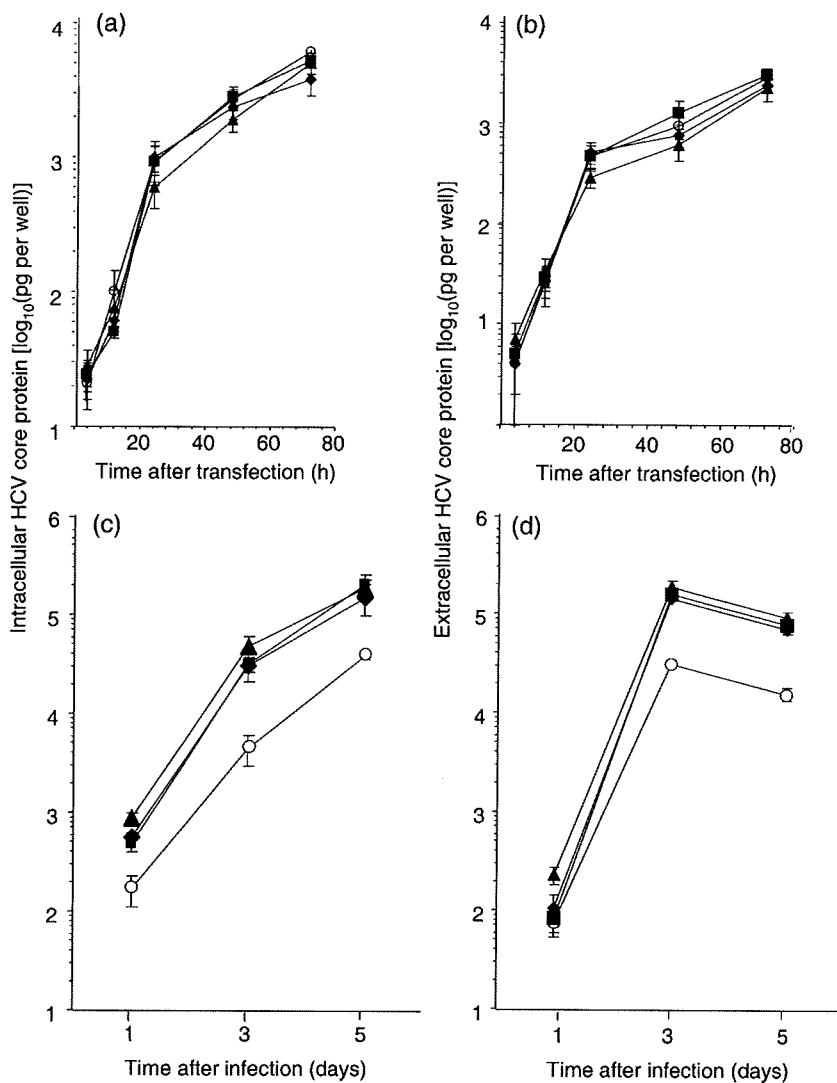

Fig. 5. Effects of adaptive mutations on the production of intracellular and extracellular core protein after transfection of *in vitro*-translated HCV RNAs or after infection of recombinant HCV. (a, b) After electroporation of 10 μg *in vitro*-translated HCV RNAs P-1 (○), R-27 (▲), R-38 (◆) and R-47 (■) into Huh-7.5 cells (5×10^6), the cells were divided into five sets, replated into a six-well plate and cultured. The cells and culture supernatants were harvested at the time points given. Intracellular (a) and extracellular (b) core protein levels were quantified by core protein-specific ELISA. (c, d) After Huh-7.5 cells (1.2×10^5 cells per 12-well plate) were infected with the P-1 (○), R-27 (▲), R-38 (◆) and R-47 (■) viruses at an m.o.i. of 0.2, the cells and culture supernatants were harvested at the time points given. Intracellular (c) and extracellular (d) core protein levels were quantified by core protein-specific ELISA.

JFH-1 virus after two successive amplifications in naïve cells, although the numbers of infectious viruses in the supernatant of transfected cells were initially low (Delgrange *et al.*, 2007). Our results in the growth curves of the viruses in the transfected cells and infected cells were consistent with their report. The CD81 inhibition assay in this study demonstrated clearly that the N534H mutation of the J6/JFH-1 virus confers a selective advantage for J6/JFH-1 at the entry level. To our knowledge, the present study is the first to prove that the mutation at site N534 gives infectious HCV a selective advantage at the entry level. These results raise two possibilities. One is that the N534H mutation in the E2 glycoprotein removes *N*-glycosylation and this mutant E2 glycoprotein possesses a higher affinity for the CD81 molecule, resulting in efficient entry to the cells. Another possibility is that the E2 glycoprotein with the N534H mutation gains higher affinity for other HCV receptors. Further investigation will be required to elucidate the mechanism of this adaptive mutation.

Our results showed that a combination of the mutations in E2, together with four additional mutations in NS2, NS5A and NS5B, resulted in higher infectivity of HCV, suggesting that the additional four mutations possess an advantage at different steps.

NS2 is a membrane-associated cysteine protease (Grakoui *et al.*, 1993; Hijikata *et al.*, 1993b; Lorenz *et al.*, 2006). The N terminus of NS2 consists of one or more transmembrane domains, whilst the C-terminal domain of NS2, together with the N-terminal one-third of NS3, forms the NS2–3 protease, an enzyme that catalyses a single cleavage at the NS2/NS3 boundary. The crystal structure of the C-terminal domain of NS2 has recently been determined and reveals a dimeric protease containing two composite active sites (Lorenz *et al.*, 2006). Jones *et al.* (2007) showed that NS2 and p7 are essential for HCV infectivity. The Y852 and W879 residues are located in the hydrophobic region of NS2. Although the exact topology of NS2 is disputed, the Y852H and W879R mutations would be predicted to lie

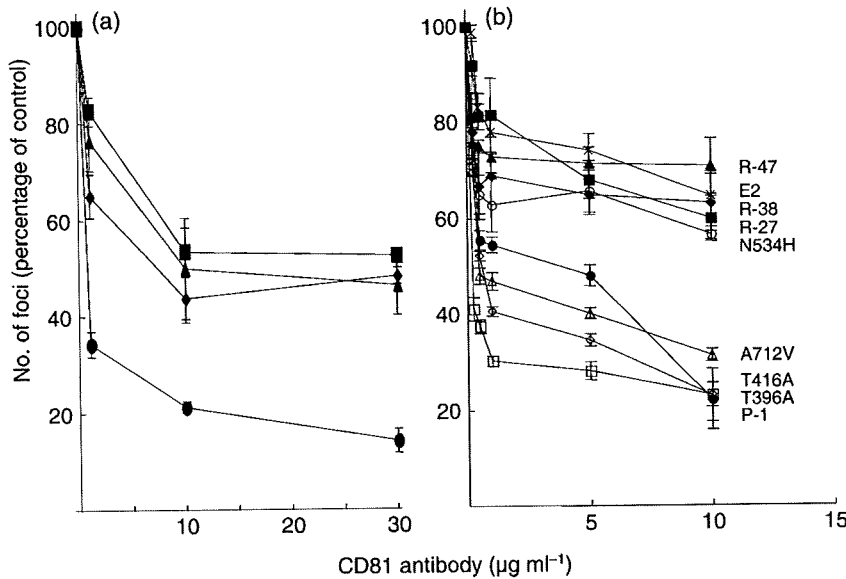

Fig. 6. Blocking of virus attachment and entry with anti-CD81 antibody. (a) Huh-7.5 cells (2×10^5 cells per six-well plate) were pretreated with 0, 1, 10 or 30 μg CD81 antibody (clone JS-81) ml^{-1} for 1 h and then infected with the wild-type (\bullet , P-1) or recombinant mutant (\blacksquare , R-27; \blacklozenge , R-38; \blacktriangle , R-47) viruses at an m.o.i. of 0.5. The cells were cultured for 24 h. The infection was monitored by HCV immunofluorescence and the numbers of HCV-positive foci were counted. Each result is expressed as a fraction of the number of foci observed in wells that received the control antibody instead of anti-CD81. Error bars represent SD for triplicate measurements. (b) Huh-7.5 cells (2×10^5 cells per six-well plate) were pretreated with 0, 0.25, 0.5, 1, 5 or 10 μg CD81 antibody ml^{-1} for 1 h and then infected with the wild-type (\bullet , P-1) or recombinant (\blacksquare , R-27; \blacklozenge , R-38; \blacktriangle , R-47; \times , E2; \square , T396A; \diamond , T416A; \circ , N534H; \triangle , A712V) viruses at an m.o.i. of 0.01. Blocking of virus entry with anti-CD81 antibody was examined. The infection was monitored by HCV immunofluorescence and the number of HCV-positive foci was counted.

within the second and third transmembrane domains, respectively (Yamaga & Ou, 2002). Murray *et al.* (2007) demonstrated that the A880P mutation increased infectious virus production significantly in the context of the J6/JFH1 genome, suggesting that the mutations in the transmembrane domain of NS2 play an important role in HCV infectivity. It is possible that the Y852H and W879R mutations in the transmembrane domain affect the topology and localization of NS2, and thereby HCV infectivity. Interestingly, NS2 has been found to interact with all other HCV NS proteins in *in vitro* pull-down assays, as well as cell-based colocalization and co-immunoprecipitation experiments (Dimitrova *et al.*, 2003; Hijikata *et al.*, 1993b), suggesting a role for NS2 as part of the replication complex.

Sequence analyses of HCV replicon cells revealed that highly adaptive mutations lie within the NS4B, NS5A and NS5B coding regions, with the majority clustering in NS5A. However, the mechanism underlying the replication enhancement is not known (Bartenschlager & Sparacio, 2007). The mutant viruses possessed an F2281L mutation that was located in domain II of NS5A. NS5A is an RNA-binding phosphoprotein composed of three domains that are separated by trypsin-sensitive low-complexity sequences (LCS I and LCS II) and an N-terminal amphipathic α -helix that anchors the protein stably to intracellular membranes (Brass *et al.*, 2002; Penin *et al.*, 2004; Tellinghuisen *et al.*, 2004). According to the X-ray

crystal structure of domain I, it forms a dimer with a claw-like shape that can accommodate a single-stranded RNA molecule (Tellinghuisen *et al.*, 2005). Domain III of NS5A plays an important role in virus assembly and the production of infectious particles (Appel *et al.*, 2008; Masaki *et al.*, 2008; Tellinghuisen *et al.*, 2008). However, the role played by domain II of NS5A in the HCV replication cycle is unknown. Further examination will be required to clarify the effects of the F2281L mutation on the infectivity of the virus. Kaul *et al.* (2007) reported the V2941M mutation in NS5B in the context of the JFH1 genome. Lohmann *et al.* (2001) reported the R2884G mutation in the context of Con1-based replicon cells. Amino acid substitutions within NS5B may favour HCV replication and virus production in ways that remain to be determined.

Miyazaki *et al.* (2007) proposed that HCV NS proteins and replication complexes are recruited to lipid droplet-associated membranes by the HCV core protein and that this recruitment is critical for producing infectious viruses. Cholesterol and sphingolipid associated with HCV particles are important for virion maturation and infectivity (Aizaki *et al.*, 2008). We speculate that the additional four mutations in NS2, NS5A and NS5B may confer an advantage in the maturation of virus particles or modification of virus envelopes with cholesterol and sphingolipid. Further investigation will be necessary to elucidate the mechanism of the adaptive mutations in NS2, NS5A and NS5B.

In conclusion, we have developed an efficient HCV-production system by passaging HCV J6/JFH1-infected Huh-7.5 cells. We have demonstrated that an efficient HCV-production system could be obtained by introducing adaptive mutations into the J6/JFH1 genome. The J6/JFH1-derived mutant viruses presented here would be a good tool for producing HCV particles with enhanced infectivity and for studying the molecular mechanism of HCV entry.

ACKNOWLEDGEMENTS

The authors are grateful to Dr C. M. Rice (Center for the Study of Hepatitis C, the Rockefeller University, New York, NY, USA) for providing pFL-J6/JFH1 and Huh-7.5 cells. This work was supported in part by grants-in-aid for Scientific Research from the Ministry of Education, Culture, Sports, Science and Technology (MEXT), and the Ministry of Health, Labour and Welfare, Japan. This study was also carried out as part of the Program of Founding Research Centers for Emerging and Reemerging Infectious Diseases, MEXT, Japan. This study was also part of the Global Center of Excellence (COE) Program at Kobe University Graduate School of Medicine.

REFERENCES

- Aizaki, H., Morikawa, K., Fukasawa, M., Hara, H., Inoue, Y., Tani, H., Saito, K., Nishijima, M., Hanada, K. & other authors (2008). Critical role of virion-associated cholesterol and sphingolipid in hepatitis C virus infection. *J Virol* **82**, 5715–5724.
- Appel, N., Zayas, M., Miller, S., Krijnse-Locker, J., Schaller, T., Friebe, P., Kallis, S., Engel, U. & Bartenschlager, R. (2008). Essential role of domain III of nonstructural protein 5A for hepatitis C virus infectious particle assembly. *PLoS Pathog* **4**, e1000035.
- Bartenschlager, R. & Sparacio, S. (2007). Hepatitis C virus molecular clones and their replication capacity *in vivo* and in cell culture. *Virus Res* **127**, 195–207.
- Bartosch, B., Vitelli, A., Granier, C., Goujon, C., Dubuisson, J., Pascale, S., Scarselli, E., Cortese, R., Nicosia, A. & Cosset, F. L. (2003). Cell entry of hepatitis C virus requires a set of co-receptors that include the CD81 tetraspanin and the SR-B1 scavenger receptor. *J Biol Chem* **278**, 41624–41630.
- Blight, K. J., Kolykhalov, A. A. & Rice, C. M. (2000). Efficient initiation of HCV RNA replication in cell culture. *Science* **290**, 1972–1974.
- Blight, K. J., McKeating, J. A. & Rice, C. M. (2002). Highly permissive cell lines for subgenomic and genomic hepatitis C virus RNA replication. *J Virol* **76**, 13001–13014.
- Brass, V., Bieck, E., Montserret, R., Wolk, B., Hellings, J. A., Blum, H. E., Penin, F. & Moradpour, D. (2002). An amino-terminal amphipathic alpha-helix mediates membrane association of the hepatitis C virus nonstructural protein 5A. *J Biol Chem* **277**, 8130–8139.
- Choo, Q. L., Kuo, G., Weiner, A. J., Overby, L. R., Bradley, D. W. & Houghton, M. (1989). Isolation of a cDNA clone derived from a blood-borne non-A, non-B viral hepatitis genome. *Science* **244**, 359–362.
- Choo, Q. L., Richman, K. H., Han, J. H., Berger, K., Lee, C., Dong, C., Gallegos, C., Coit, D., Medina-Selby, R. & other authors (1991). Genetic organization and diversity of the hepatitis C virus. *Proc Natl Acad Sci U S A* **88**, 2451–2455.
- Delgrange, D., Pillez, A., Castelain, S., Cocquerel, L., Rouille, Y., Dubuisson, J., Wakita, T., Duverlie, G. & Wychowski, C. (2007). Robust production of infectious viral particles in Huh-7 cells by introducing mutations in hepatitis C virus structural proteins. *J Gen Virol* **88**, 2495–2503.
- Dimitrova, M., Imbert, I., Kieny, M. P. & Schuster, C. (2003). Protein-protein interactions between hepatitis C virus nonstructural proteins. *J Virol* **77**, 5401–5414.
- Evans, M. J., von Hahn, T., Tscherne, D. M., Syder, A. J., Panis, M., Wolk, B., Hatzioannou, T., McKeating, J. A., Bieniasz, P. D. & Rice, C. M. (2007). Claudin-1 is a hepatitis C virus co-receptor required for a late step in entry. *Nature* **446**, 801–805.
- Goffard, A., Callens, N., Bartosch, B., Wychowski, C., Cosset, F. L., Montpellier, C. & Dubuisson, J. (2005). Role of N-linked glycans in the functions of hepatitis C virus envelope glycoproteins. *J Virol* **79**, 8400–8409.
- Gottwein, J. M., Scheel, T. K., Hoegh, A. M., Lademann, J. B., Eugen-Olsen, J., Lisby, G. & Bukh, J. (2007). Robust hepatitis C genotype 3a cell culture releasing adapted intergenotypic 3a/2a (S52/JFH1) viruses. *Gastroenterology* **133**, 1614–1626.
- Grakoui, A., McCourt, D. W., Wychowski, C., Feinstone, S. M. & Rice, C. M. (1993). A second hepatitis C virus-encoded proteinase. *Proc Natl Acad Sci U S A* **90**, 10583–10587.
- Helle, F. & Dubuisson, J. (2008). Hepatitis C virus entry into host cells. *Cell Mol Life Sci* **65**, 100–112.
- Hijikata, M., Mizushima, H., Akagi, T., Mori, S., Kakiuchi, N., Kato, N., Tanaka, T., Kimura, K. & Shimotohno, K. (1993a). Two distinct proteinase activities required for the processing of a putative nonstructural precursor protein of hepatitis C virus. *J Virol* **67**, 4665–4675.
- Hijikata, M., Mizushima, H., Tanji, Y., Komoda, Y., Hirowatari, Y., Akagi, T., Kato, N., Kimura, K. & Shimotohno, K. (1993b). Proteolytic processing and membrane association of putative nonstructural proteins of hepatitis C virus. *Proc Natl Acad Sci U S A* **90**, 10773–10777.
- Jones, C. T., Murray, C. L., Eastman, D. K., Tassello, J. & Rice, C. M. (2007). Hepatitis C virus p7 and NS2 proteins are essential for production of infectious virus. *J Virol* **81**, 8374–8383.
- Kaul, A., Woerz, I., Meuleman, P., Leroux-Roels, G. & Bartenschlager, R. (2007). Cell culture adaptation of hepatitis C virus and *in vivo* viability of an adapted variant. *J Virol* **81**, 13168–13179.
- Kuo, G., Choo, Q. L., Alter, H. J., Gitnick, G. L., Redeker, A. G., Purcell, R. H., Miyamura, T., Dienstag, J. L., Alter, M. J. & other authors (1989). An assay for circulating antibodies to a major etiologic virus of human non-A, non-B hepatitis. *Science* **244**, 362–364.
- Lindenbach, B. D., Evans, M. J., Syder, A. J., Wolk, B., Tellinghuisen, T. L., Liu, C. C., Maruyama, T., Hynes, R. O., Burton, D. R. & other authors (2005). Complete replication of hepatitis C virus in cell culture. *Science* **309**, 623–626.
- Lohmann, V., Korner, F., Koch, J., Herian, U., Theilmann, L. & Bartenschlager, R. (1999). Replication of subgenomic hepatitis C virus RNAs in a hepatoma cell line. *Science* **285**, 110–113.
- Lohmann, V., Korner, F., Dobierzewska, A. & Bartenschlager, R. (2001). Mutations in hepatitis C virus RNAs conferring cell culture adaptation. *J Virol* **75**, 1437–1449.
- Lorenz, I. C., Marcotrigiano, J., Dentzer, T. G. & Rice, C. M. (2006). Structure of the catalytic domain of the hepatitis C virus NS2–3 protease. *Nature* **442**, 831–835.
- Manns, M. P., Foster, G. R., Rockstroh, J. K., Zeuzem, S., Zoulim, F. & Houghton, M. (2007). The way forward in HCV treatment – finding the right path. *Nat Rev Drug Discov* **6**, 991–1000.
- Masaki, T., Suzuki, R., Murakami, K., Aizaki, H., Ishii, K., Murayama, A., Date, T., Matsuura, Y., Miyamura, T., Wakita, T. & Suzuki, T. (2008). Interaction of hepatitis C virus nonstructural protein 5A with core

- protein is critical for the production of infectious virus particles. *J Virol* **82**, 7964–7976.
- McLaughlan, J., Lemberg, M. K., Hope, G. & Martoglio, B. (2002). Intramembrane proteolysis promotes trafficking of hepatitis C virus core protein to lipid droplets. *EMBO J* **21**, 3980–3988.
- Miyanari, Y., Atsuzawa, K., Usuda, N., Watashi, K., Hishiki, T., Zayas, M., Bartenschlager, R., Wakita, T., Hijikata, M. & Shimotohno, K. (2007). The lipid droplet is an important organelle for hepatitis C virus production. *Nat Cell Biol* **9**, 1089–1097.
- Muramatsu, S., Ishido, S., Fujita, T., Itoh, M. & Hotta, H. (1997). Nuclear localization of the NS3 protein of hepatitis C virus and factors affecting the localization. *J Virol* **71**, 4954–4961.
- Murray, C. L., Jones, C. T., Tassello, J. & Rice, C. M. (2007). Alanine scanning of the hepatitis C virus core protein reveals numerous residues essential for production of infectious virus. *J Virol* **81**, 10220–10231.
- Owsianka, A. M., Timms, J. M., Tarr, A. W., Brown, R. J., Hickling, T. P., Szejka, A., Bienkowska-Szewczyk, K., Thomson, B. J., Patel, A. H. & Ball, J. K. (2006). Identification of conserved residues in the E2 envelope glycoprotein of the hepatitis C virus that are critical for CD81 binding. *J Virol* **80**, 8695–8704.
- Penin, F., Brass, V., Appel, N., Ramboarina, S., Montserret, R., Ficheux, D., Blum, H. E., Bartenschlager, R. & Moradpour, D. (2004). Structure and function of the membrane anchor domain of hepatitis C virus nonstructural protein 5A. *J Biol Chem* **279**, 40835–40843.
- Pietschmann, T., Lohmann, V., Kaul, A., Krieger, N., Rinck, G., Rutter, G., Strand, D. & Bartenschlager, R. (2002). Persistent and transient replication of full-length hepatitis C virus genomes in cell culture. *J Virol* **76**, 4008–4021.
- Pileri, P., Uematsu, Y., Campagnoli, S., Galli, G., Falugi, F., Petracca, R., Weiner, A. J., Houghton, M., Rosa, D. & other authors (1998). Binding of hepatitis C virus to CD81. *Science* **282**, 938–941.
- Poynard, T., Yuen, M. F., Ratziu, V. & Lai, C. L. (2003). Viral hepatitis C. *Lancet* **362**, 2095–2100.
- Roccasecca, R., Ansuini, H., Vitelli, A., Meola, A., Scarselli, E., Acali, S., Pezzanera, M., Ercole, B. B., McKeating, J. & other authors (2003). Binding of the hepatitis C virus E2 glycoprotein to CD81 is strain specific and is modulated by a complex interplay between hypervariable regions 1 and 2. *J Virol* **77**, 1856–1867.
- Russell, R. S., Meunier, J. C., Takikawa, S., Faulk, K., Engle, R. E., Bukh, J., Purcell, R. H. & Emerson, S. U. (2008). Advantages of a single-cycle production assay to study cell culture-adaptive mutations of hepatitis C virus. *Proc Natl Acad Sci U S A* **105**, 4370–4375.
- Saito, I., Miyamura, T., Ohbayashi, A., Harada, H., Katayama, T., Kikuchi, S., Watanabe, Y., Koi, S., Onji, M. & other authors (1990). Hepatitis C virus infection is associated with the development of hepatocellular carcinoma. *Proc Natl Acad Sci U S A* **87**, 6547–6549.
- Scarselli, E., Ansuini, H., Cerino, R., Roccasecca, R. M., Acali, S., Filocamo, G., Traboni, C., Nicosia, A., Cortese, R. & Vitelli, A. (2002). The human scavenger receptor class B type I is a novel candidate receptor for the hepatitis C virus. *EMBO J* **21**, 5017–5025.
- Schaller, T., Appel, N., Koutsoudakis, G., Kallis, S., Lohmann, V., Pietschmann, T. & Bartenschlager, R. (2007). Analysis of hepatitis C virus superinfection exclusion by using novel fluorochrome gene-tagged viral genomes. *J Virol* **81**, 4591–4603.
- Sumpter, R., Jr, Loo, Y. M., Foy, E., Li, K., Yoneyama, M., Fujita, T., Lemon, S. M. & Gale, M., Jr (2005). Regulating intracellular antiviral defense and permissiveness to hepatitis C virus RNA replication through a cellular RNA helicase, RIG-I. *J Virol* **79**, 2689–2699.
- Takigawa, Y., Nagano-Fujii, M., Deng, L., Hidajat, R., Tanaka, M., Mizuta, H. & Hotta, H. (2004). Suppression of hepatitis C virus replicon by RNA interference directed against the NS3 and NS5B regions of the viral genome. *Microbiol Immunol* **48**, 591–598.
- Tellinghuisen, T. L., Marcotrigiano, J., Gorbalenya, A. E. & Rice, C. M. (2004). The NS5A protein of hepatitis C virus is a zinc metalloprotein. *J Biol Chem* **279**, 48576–48587.
- Tellinghuisen, T. L., Marcotrigiano, J. & Rice, C. M. (2005). Structure of the zinc-binding domain of an essential component of the hepatitis C virus replicase. *Nature* **435**, 374–379.
- Tellinghuisen, T. L., Foss, K. L., Treadaway, J. C. & Rice, C. M. (2008). Identification of residues required for RNA replication in domains II and III of the hepatitis C virus NS5A protein. *J Virol* **82**, 1073–1083.
- Wakita, T., Pietschmann, T., Kato, T., Date, T., Miyamoto, M., Zhao, Z., Murthy, K., Habermann, A., Krausslich, H. G. & other authors (2005). Production of infectious hepatitis C virus in tissue culture from a cloned viral genome. *Nat Med* **11**, 791–796.
- Yamaga, A. K. & Ou, J. H. (2002). Membrane topology of the hepatitis C virus NS2 protein. *J Biol Chem* **277**, 33228–33234.
- Yi, M., Villanueva, R. A., Thomas, D. L., Wakita, T. & Lemon, S. M. (2006). Production of infectious genotype 1a hepatitis C virus (Hutchinson strain) in cultured human hepatoma cells. *Proc Natl Acad Sci U S A* **103**, 2310–2315.
- Yi, M., Ma, Y., Yates, J. & Lemon, S. M. (2007). Compensatory mutations in E1, p7, NS2, and NS3 enhance yields of cell culture-infectious intergenotypic chimeric hepatitis C virus. *J Virol* **81**, 629–638.
- Zhong, J., Gastaminza, P., Cheng, G., Kapadia, S., Kato, T., Burton, D. R., Wieland, S. F., Uprichard, S. L., Wakita, T. & Chisari, F. V. (2005). Robust hepatitis C virus infection *in vitro*. *Proc Natl Acad Sci U S A* **102**, 9294–9299.
- Zhong, J., Gastaminza, P., Chung, J., Stamataki, Z., Isogawa, M., Cheng, G., McKeating, J. A. & Chisari, F. V. (2006). Persistent hepatitis C virus infection *in vitro*: coevolution of virus and host. *J Virol* **80**, 11082–11093.

HCV replication suppresses cellular glucose uptake through down-regulation of cell surface expression of glucose transporters[☆]

Daisuke Kasai^{1,†}, Tetsuya Adachi^{1,†}, Lin Deng¹, Motoko Nagano-Fujii¹, Kiyonao Sada¹, Masanori Ikeda², Nobuyuki Kato², Yoshi-Hiro Ide¹, Ikuo Shoji¹, Hak Hotta^{1,*}

¹Divisions of Microbiology, Kobe University Graduate School of Medicine, 7-5-1 Kusunoki-cho, Chuo-ku, Kobe 650-0017, Japan

²Department of Molecular Biology, Okayama University Graduate School of Medicine and Dentistry, Okayama, Japan

See Editorial, pages 845–847

Background/Aims: Persistent infection with hepatitis C virus (HCV) causes extrahepatic diseases, including diabetes. We investigated the possible effect(s) of HCV replication on cellular glucose uptake and expression of the facilitative glucose transporter (GLUT) 2 and 1.

Methods: We used Huh-7.5 cells harboring either an HCV subgenomic RNA replicon (SGR) or an HCV full-genomic RNA replicon (FGR), HCV-infected cells, and the respective cells treated with interferon (IFN). We also used liver tissue samples obtained from patients with or without HCV infection.

Results: Glucose uptake and surface expression of GLUT2 and GLUT1 were suppressed in SGR, FGR and HCV-infected cells compared to the control cells. Expression levels of GLUT2 mRNA, but not GLUT1 mRNA, were lower in SGR, FGR and HCV-infected cells than in the control. Luciferase reporter assay demonstrated decreased GLUT2 promoter activities in SGR, FGR and HCV-infected cells. IFN treatment restored glucose uptake, GLUT2 surface expression, GLUT2 mRNA expression and GLUT2 promoter activities. Also, GLUT2 expression was reduced in hepatocytes of liver tissues obtained from HCV-infected patients.

Conclusions: HCV replication down-regulates cell surface expression of GLUT2 partly at the transcriptional level, and possibly at the intracellular trafficking level as suggested for GLUT1, thereby lowering glucose uptake by hepatocytes.

© 2009 European Association for the Study of the Liver. Published by Elsevier B.V. All rights reserved.

Keywords: Diabetes mellitus; Down-regulation; Glucose uptake; GLUT1; GLUT2; Hepatitis C virus; Hepatocyte; Interferon; Replicon

1. Introduction

Hepatitis C virus (HCV) is a small, enveloped RNA virus, which belongs to the genus *Hepacivirus* within the family *Flaviviridae*. The viral genome consists of single-stranded, positive-sense RNA of 9.6 kb that encodes a polyprotein of about 3000 amino acids. There are six major genotypes of HCV worldwide, with each genotype being further classified into a number of subtypes, such as HCV-1a and -1b [1,2]. The polyprotein is processed by host cellular and viral proteases to yield at least 10 structural and nonstructural (NS) proteins, such

Received 15 June 2008; received in revised form 19 November 2008; accepted 11 December 2008; available online 27 February 2009

Associate Editor: F. Zoulim

[☆] The authors who have taken part in the research of this manuscript declared that they do not have a relationship with the manufacturers of the materials involved either in the past or present and they did not receive funding from the manufacturers to carry out their research.

* Corresponding author. Tel.: +81 78 3825500; fax: +81 78 3825519.

E-mail address: hotta@kobe-u.ac.jp (H. Hotta).

† These authors contributed equally to this work.

Abbreviations: FGR, full-genome RNA replicon; GLUT, glucose transporter; HBV, hepatitis B virus; HCV, hepatitis C virus; IFN, interferon; SGR, subgenomic RNA replicon.

as core protein, envelope glycoproteins (E1 and E2), p7, NS2, NS3, NS4A, NS4B, NS5A and NS5B [3,4].

HCV prevails in most parts of the world with an estimated number of about 170 million carriers and, hence, HCV infection is a major global healthcare problem [5]. Persistent infection with HCV causes not only liver diseases, including hepatitis, but also extrahepatic manifestations, such as type 2 diabetes [6–8]. While it has been known that liver cirrhosis impairs the glucose metabolism of the liver, there are some reports showing that HCV-infected patients over 40 years old have an increased risk for type 2 diabetes – three times higher than that for patients without HCV infection [9,10]. These reports imply the possibility that HCV infection directly predisposes the host towards type 2 diabetes. However, the precise mechanism(s) is poorly understood.

Glucose is transported into the cell via various isoforms of the facilitative glucose transporter (GLUT) that are present in most cells. Currently, a total of 14 isoforms have been identified in the GLUT family [11–13]. GLUT2 is expressed tissue-specifically in the liver, pancreatic β -cells, hypothalamic glial cells, retina and enterocytes [14]. On the other hand, GLUT1 is expressed at high levels in all fetal tissues and, in adults, it is widely expressed but most abundant in erythrocytes, endothelial cells of the blood–brain barrier, renal tubules of the kidney, and any kind of malignant cells including hepatocellular carcinoma [13].

In the present study, we demonstrated that HCV infection suppressed hepatocytic glucose uptake through down-regulation of surface expression of GLUT in a human hepatocellular carcinoma-derived cell line Huh-7.5. We also demonstrated that GLUT2 expression in hepatocytes of the liver tissues from HCV-infected patients was lower than in those from patients without HCV infection. We propose that HCV replication decreases glucose uptake and cell surface expression of GLUT, which would eventually lead to glucose metabolism disorder.

2. Materials and methods

2.1. Cell culture, HCV RNA replication, HCV infection and IFN treatment

A human hepatoma-derived cell line, Huh-7.5, which is highly permissive to HCV RNA replication [15], was kindly provided by Dr. C.M. Rice (The Rockefeller University, New York, NY, USA). The cells were maintained in Dulbecco's modified Eagle's medium supplemented with 10% heat-inactivated fetal calf serum.

Huh-7.5 cells stably harboring an HCV-1b subgenomic RNA replicon (referred to as SGR cells, hereafter) were prepared as describe previously [16–18], using pFK5B/2884Gly (a kind gift from Dr. R. Bartenschlager, University of Heidelberg, Heidelberg, Germany). In SGR cells, the HCV subgenomic RNA replicon autonomously replicates to express NS3 to NS5B of HCV (Fig. 1). Cells harboring a full-length HCV-1b RNA replicon derived from pON/C-5B (referred to as FGR cells, hereafter) were described previously [19,20]. In

FGR cells, the genome-size HCV RNA replicon autonomously replicates to express all the HCV proteins (the core protein, E1, E2, p7, NS2, NS3 to NS5B).

The pFL-J6/JFH1 plasmid that encodes the entire viral genome of a chimeric strain of HCV-2a, J6/JFH1 [21], was kindly provided by Dr. C.M. Rice. The HCV RNA genome was transcribed *in vitro* from pFL-J6/JFH1 and transfected to Huh-7.5 cells. The virus produced in the culture supernatant was used for infection experiments at multiplicities of infection of 1.0 and cultured for 5 days after virus infection.

In some experiments, SGR and FGR cells, as well as HCV-infected cells at 5 days after virus infection, were treated with 1000 IU/ml of IFN (Sigma, St. Louis, MI, USA) for 10 days to eliminate HCV replication.

2.2. Immunofluorescence

Cells were fixed with 3.7% paraformaldehyde and incubated with mouse monoclonal antibody against HCV NS5A (Chemicon International, Inc., Temecula, CA, USA) or HCV core (Abcam, Tokyo, Japan). The cells were then incubated with fluorescein isothiocyanate (FITC)-conjugated goat anti-mouse IgG (MBL Co. Ltd., Nagoya, Japan), and observed under a fluorescent microscope (BX51; Olympus, Tokyo, Japan).

2.3. Immunoblotting

Cells were solubilized in lysis buffer as reported previously [22]. The cell lysates were electrophoresed subjected to 8% polyacrylamide gel electrophoresis and transferred to polyvinylidene difluoride membrane (Millipore Corp., Billerica, MA, USA). The membranes were incubated with mouse monoclonal antibodies against HCV NS5A or NS3 (Chemicon), followed by incubation with peroxidase-conjugated goat anti-mouse IgG (MBL). The positive bands were visualized by using ECL detection system (GE Healthcare UK Ltd., Buckinghamshire, UK).

2.4. Uptake of 2-deoxy-D-glucose and thymidine

Cells cultured in 12-well plates were deprived of serum by incubation in serum-free medium for 12 h. The cells were then pre-incubated for 20 min in 450 μ l of KRH (25 mM Hepes, 120 mM NaCl, 5 mM KCl, 1.2 mM MgSO₄, 1.3 mM CaCl₂, 1.3 mM KH₂PO₄ and 0.1% BSA, pH 7.4). Glucose uptake assay was performed as describe previously [23]. In brief, glucose uptake was initiated by addition of 50 μ l of reaction solution (KRH containing 0.5 mM, 0.25 μ Ci 2-deoxy-D-[1,2-³H]glucose) to each well. As a negative control, 100 μ M phloretin was added to reaction solution. After 10 min, transport was terminated by washing the cells with ice-cold KRH buffer containing 100 μ M phloretin. The cells were solubilized by 0.1% sodium dodecyl sulfate, and the incorporated radioactivity was measured by liquid scintillation counter (LS6500; Beckman Coulter, Fullerton, CA). In some experiments, GLUT1 and GLUT2 were ectopically expressed by using the pCAGGS expression vector [24] and glucose uptake was measured as described above.

2.5. Flow cytometry

To examine cell surface expression of GLUT1 and GLUT2, cells harvested in PBS containing 0.2% EDTA were incubated with rabbit polyclonal antibodies against GLUT1 or GLUT2 (1:200; Alpha Diagnostic International, San Antonio, TX, USA) on ice for 1 h. After being washed, the cells were incubated with FITC-labeled goat anti-rabbit IgG (1:200; BD Pharmingen, Franklin Lakes, NJ, USA) on ice for another 1 h. Analysis was carried out using flow cytometer and a total of 10,000 live cell events were measured. Results were displayed graphically as overlaying histograms demonstrating the shift of the mean FITC staining value.

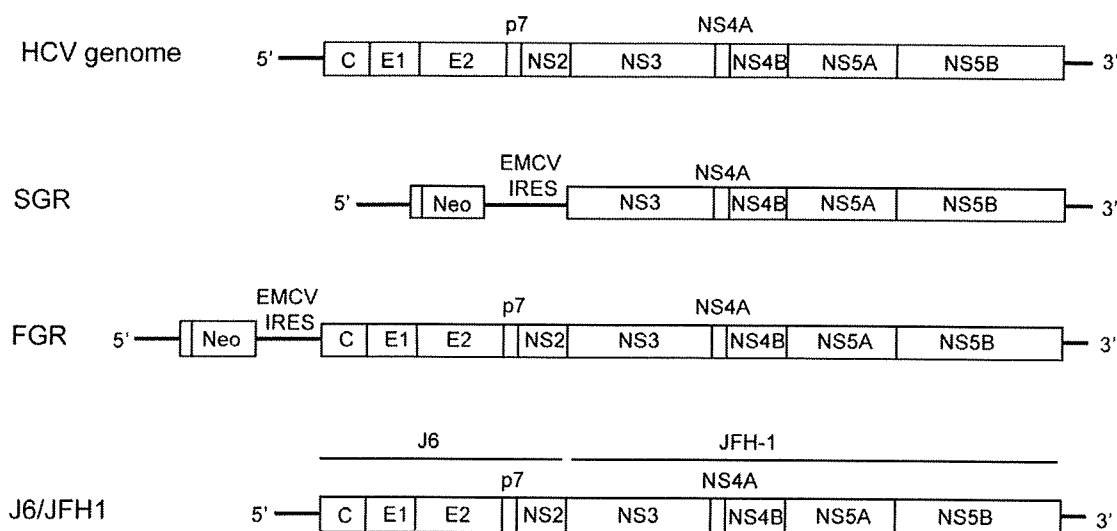

Fig. 1. The HCV genome and HCV RNA replicons. Schematic diagram of the HCV genome, SGR, FGR and the chimeric HCV J6/JFH1 genome are shown. EMCV IRES, encephalomyocarditis virus internal ribosome entry site; Neo, neomycin-resistance gene.

2.6. Real-time quantitative RT-PCR

Total cellular RNA was isolated using the TRIzol reagent (Invitrogen Corp., Carlsbad, CA, USA) and cDNA was generated using QuantiTect Reverse Transcription system (Qiagen, Valencia, CA, USA). Real-time quantitative PCR was performed on a SYBR *Premix Ex Taq* (Takara Bio, Kyoto, Japan) using SYBR green chemistry in ABI PRISM 7000 (Applied Biosystems, Foster, CA, USA). β -Glucuronidase was used as an internal control. The primers used are shown in Table 1.

2.7. Luciferase reporter assay

We constructed the human GLUT2 promoter-luciferase reporter gene (pGLUT2-1291Luc) by cloning a 1.6-kb genomic fragment that encompasses the human GLUT2 promoter (–1291 to +308) [14] into the pGL4 vector plasmid (Promega, Madison, WI, USA). pGLUT2-1291Luc thus contains a 1291-bp fragment of the human GLUT2 promoter upstream of the minimal promoter and the coding sequence of the *Photinus pyralis* (firefly) luciferase. pRL-CMV-*Renilla* (Promega) was used as an internal control. Cells were transfected with pGLUT2-1291Luc (1 μ g) and pRL-CMV-*Renilla* (10 ng). After 24 h, a luciferase assay was performed by using Dual-luciferase reporter assay system (Promega). Firefly and *Renilla* luciferase activities were measured by Lumat LB 9501 (Berthold, Bad Wildbad, Germany). Firefly luciferase activity was normalized to *Renilla* luciferase activity for each sample.

2.8. Immunohistochemistry

Human adult liver autopsy materials and surgically removed liver tissues of patients with HCV- or HBV-associated hepatocellular carcinoma, and those with metastatic liver cancer were obtained with written informed consent. The tissues were fixed with 10% buffered formalin (pH 7.0), embedded in paraffin and sectioned at intervals of 4 μ m. Immunohistochemical staining was performed with a DAKO ENVISION+ Kit (Dako, Glostrup, Denmark). In brief, fixed sections were treated with 3% hydrogen peroxide, and were autoclaved at 121 $^{\circ}$ C for 20 min. Then, the sections were incubated with a blocking solution and then with either anti-GLUT2 rabbit polyclonal antibody (Santa Cruz Biotechnology, Santa Cruz, CA, USA) or normal rabbit IgG (Santa Cruz Biotechnology) as a control. The sections were incubated with horseradish peroxidase-labeled polymer-conjugated goat anti-rabbit IgG, followed by incubation in a chromogenic solution. The sections were then counterstained with hematoxylin and examined with a light microscope. GLUT2 expression levels were arbitrarily determined by two examiners, including a pathologist, in a blinded manner.

2.9. Statistical analysis

Results were expressed as mean \pm SEM. Statistical significance was evaluated by ANOVA, and statistical significance was defined as $P < 0.05$.

Table 1
Sequences and positions of the primers used in this study.

Gene name (GenBank ID)	Primer	Position	PCR product (bp)
GLUT2 (J03810)	5'-TGGGCTGAGGAAGAGACTGT-3'	279–298	461
	5'-AGAGACTGAAGGATGGCTCG-3'	739–720	
GLUT1 (AK292791)	5'-TGAACCTGCTGGCCTTC-3'	437–453	399
	5'-GCAGCTTCTTTAGCACA-3'	835–819	
HCV NS5B (AJ238799)	5'-ACCAAGCTCAAACACTCACTCCA-3'	9191–9211	119
	5'-AGCGGGGTCGGGCACGAGACA-3'	9309–9289	
β -glucuronidase (M15182)	5'-ATCAAAAACGCAGAAAATACG-3'	1747–1767	238
	5'-ACGCAGGTGGTATCAGTCTTG-3'	1984–1964	

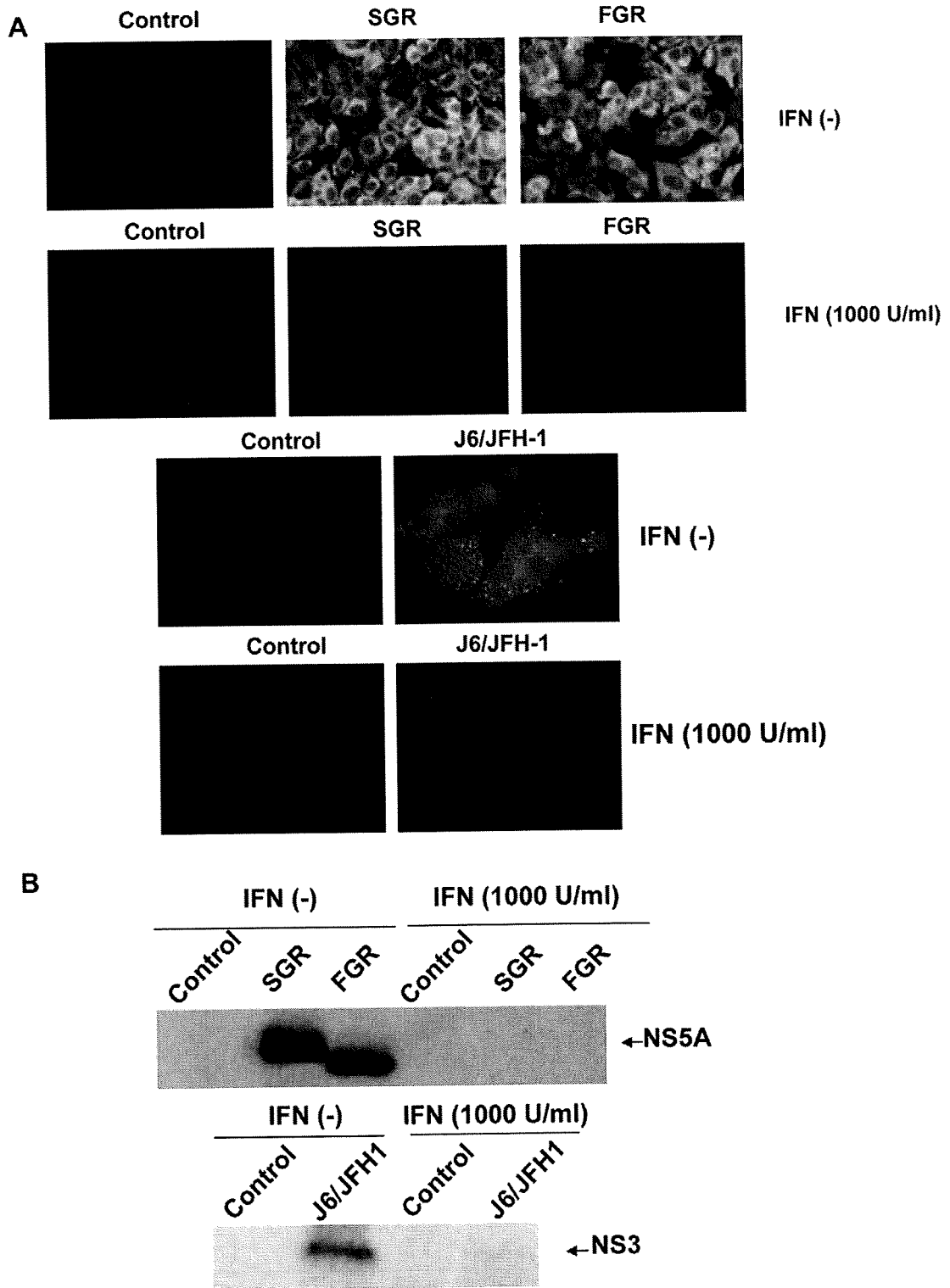

Fig. 2. Expression of HCV proteins in SGR, FGR, HCV-infected cells and the respective cells treated with IFN. (A) Cells were immunostained with anti-NS5A antibody (for SGR, FGR and the control cells) or anti-core antibody (for HCV-infected cells and the control). In parallel, cells were treated with IFN (1000 IU/ml) for 10 days to eliminate HCV replication before being subjected to immunostaining. (B) Cells were analyzed by immunoblotting with anti-NS5A antibody (upper panel) or anti-NS3 antibody (lower panel). In parallel, cells were treated with IFN (1,000 IU/ml) for 10 days to eliminate HCV replication before being subjected to immunoblotting.

3. Results

3.1. HCV protein expression in SGR, FGR, HCV-infected cells and those treated with IFN

Immunofluorescence analysis revealed that almost all the cells in SGR and FGR cultures, and >90% of the cells in the HCV J6/JFH1-infected culture were positive for HCV antigens (Fig. 2A). Western blot analysis also confirmed HCV protein expression in SGR, FGR and HCV-infected cells (Fig. 2B). In some experiments, HCV replication in SGR, FGR and HCV-infected cells was eliminated by IFN treatment for 10 days (Fig. 2A and B).

3.2. Selective suppression of cellular glucose uptake by HCV replication

2-Deoxyglucose uptake levels in SGR, FGR and HCV-infected cells were significantly suppressed by about 50–60%, compared with the control Huh-7.5 cells (Fig. 3A and B). On the other hand, thymidine uptake, which was used as a control, did not significantly differ among all the cells tested (data not shown). Moreover, glucose uptake levels in SGR, FGR and HCV-infected cells were restored by IFN treatment (Fig. 3A and B). These results strongly suggest that cellular glucose uptake is selectively suppressed by HCV RNA replication.

3.3. Down-regulation of cell surface expression of GLUT2 and GLUT1 by HCV replication

GLUT2 is the principal glucose transporter of hepatocytes *in vivo* while GLUT1 is expressed in a wide vari-

ety of cultured cells. We therefore examined cell surface expression of GLUT2 and GLUT1 by flow cytometry analysis. As shown in Fig. 4A, cell surface expression of GLUT2 and GLUT1 was markedly down-regulated in SGR and FGR cells, compared with the control. On the other hand, cell surface expression of transferrin receptor was not significantly suppressed in SGR or FGR, compared with the control, with the result ensuring the specificity of the down-regulation of GLUT2 and GLUT1 cell surface expression in SGR and FGR (Fig. 4A). Moreover, treatment of SGR and FGR cells with IFN restored the surface expression of GLUT2 and GLUT1 (Fig. 4A). These results suggest that HCV RNA replication specifically mediates down-regulation of GLUT2 and GLUT1.

Down-regulation of GLUT2 surface expression was observed also in HCV-infected cells (Fig. 4B). On the other hand, down-regulation of GLUT1 surface expression was only marginal and, compared to that of GLUT2, less evidently observed in HCV-infected cells. As a control, cell surface expression of transferrin receptor did not differ at all between HCV-infected cells and the control. Again, treatment of HCV-infected cells with IFN restored surface expression of GLUT2 (Fig. 4B).

3.4. Proteasomal degradation is not involved in the down-regulation of GLUT2 or GLUT1

Some viruses down-regulate cell surface molecules, such as immunoreceptors and intercellular adhesion molecules, through ubiquitination and proteasomal degradation of the target proteins [25]. To test this possibility, we treated SGR and FGR cells with lactacystin, a potent proteasome inhibitor. While lactacystin treatment enhanced cell surface expression of transferrin receptor, the same treatment did not increase cell surface expression of GLUT2 or GLUT1 in SGR or FGR cells (Fig. 5). This result suggested that down-regulation of cell surface expression of GLUT2 or GLUT1 in HCV-replicating cells was not due to increased degradation through the ubiquitin–proteasome system. The result rather implied the possible involvement of another mechanism(s), e.g., transcriptional suppression and/or impaired intracellular trafficking.

3.5. Transcriptional suppression of GLUT2, but not GLUT1, by HCV replication

To examine whether HCV RNA replication suppresses GLUT2 and GLUT1 expression at the transcriptional level, we measured mRNA expression levels by quantitative RT-PCR. The results obtained revealed that GLUT2 mRNA levels were reduced significantly in SGR, FGR and HCV-infected cells, compared to the control (Fig. 6A). It should be noted that the degree of GLUT2 mRNA suppression was greater in FGR

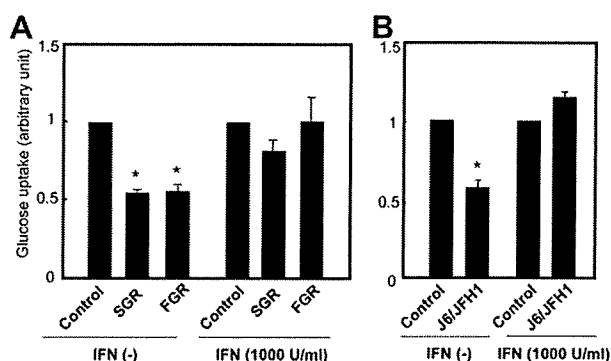

Fig. 3. Selective suppression of cellular glucose uptake by HCV replication. (A) Uptake of 2-deoxy-D-[1,2-³H] glucose in SGR, FGR and HCV-negative control. In parallel, cells were treated with IFN (1000 IU/ml) for 10 days to eliminate HCV replication before being subjected to glucose uptake analysis. Data represent mean \pm SEM of four independent experiments and the values for the control cells were arbitrarily expressed as 1.0. * $P < 0.01$, compared with the control. (B) Uptake of 2-deoxy-D-[1,2-³H] glucose in J6/JFH1-infected cells and the uninfected control. In parallel, cells at 5 days after infection were treated with IFN (1000 IU/ml) for 10 days to eliminate HCV replication before being subjected to glucose uptake analysis.

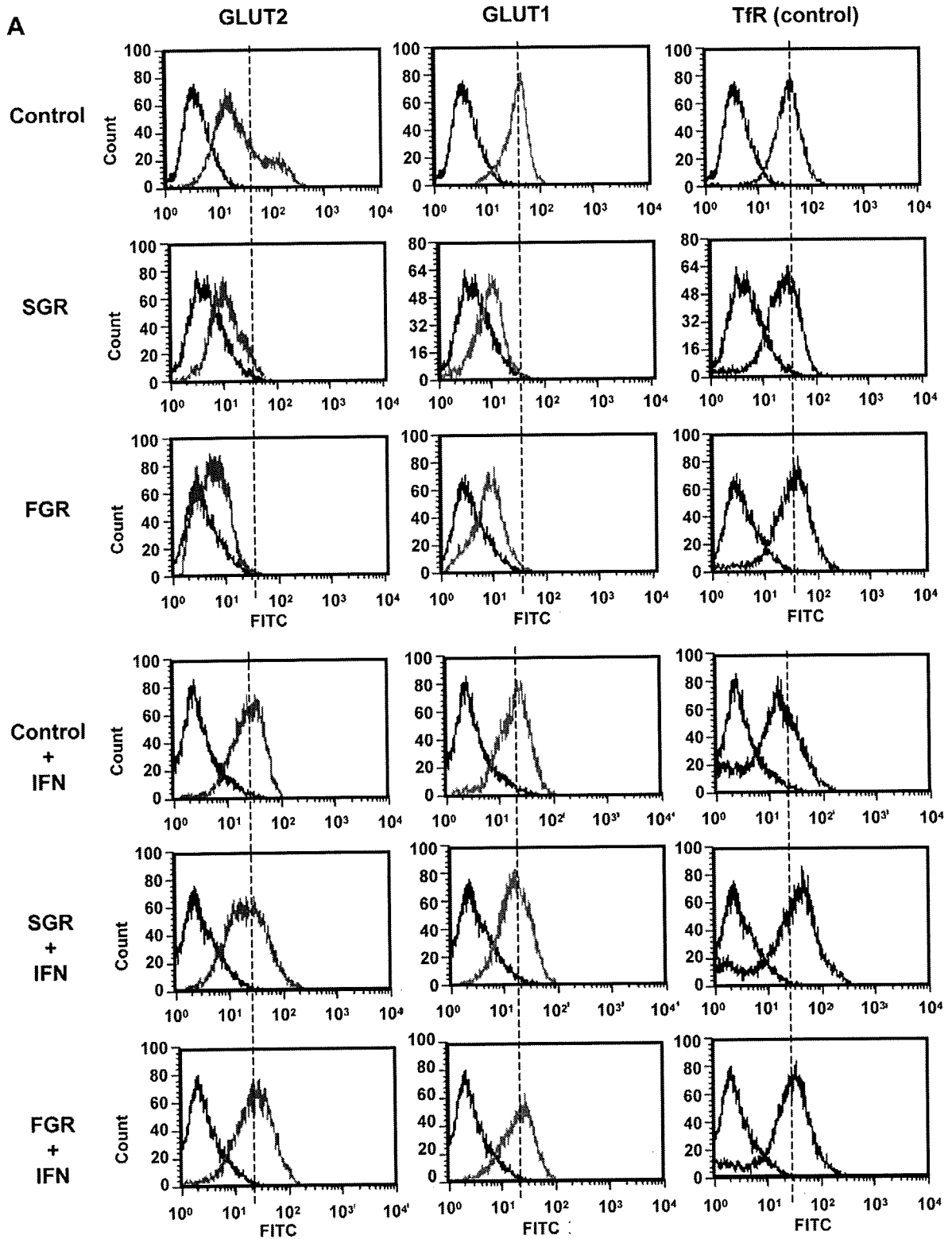

Fig. 4. Down-regulation of cell surface expressions of GLUT2 and GLUT1 by HCV replication. (A) SGR, FGR, the HCV-negative control cells were stained with specific antibodies, followed by FITC-conjugated second antibody (GLUT2, red line; GLUT1, green line) or stained with FITC-conjugated antibody alone (black line). Transferrin receptor (TfR) served as a control (blue line). In parallel, cells were treated with IFN (1000 IU/ml) for 10 days to eliminate HCV replication before being subjected to flow cytometry. (B) HCV-infected cells and the uninfected control were analyzed by flow cytometry as in (A). In parallel, cells at 5 days after infection were treated with IFN (1000 IU/ml) for 10 days to eliminate HCV replication before being subjected to flow cytometry analysis.

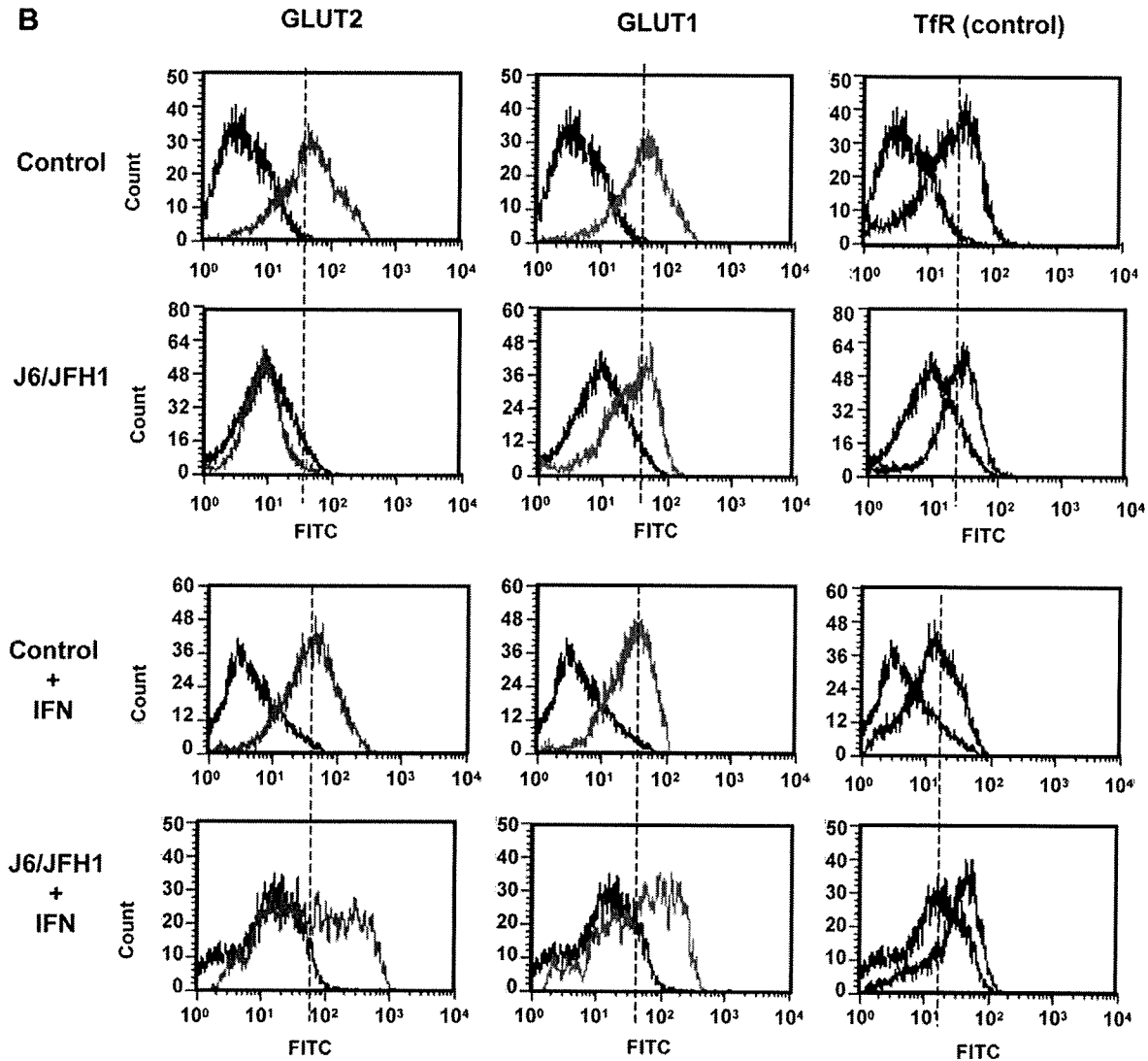

Fig. 4 (continued)

than in SGR cells. On the other hand, GLUT1 mRNA levels were not affected by HCV RNA replication (SGR and FGR) or HCV infection (Fig. 6B).

We also confirmed that GLUT2 mRNA expression levels in SGR, FGR and HCV-infected cells were restored by IFN treatment (Fig. 6A).

3.6. Suppression of GLUT2 promoter activity by HCV replication

Next, we performed luciferase reporter assay to examine the possible effect of HCV replication on GLUT2 promoter activities. The result obtained demonstrated that GLUT2 promoter activities were significantly suppressed in SGR, FGR and HCV-infected cells, compared to the control cells (Fig. 6C). Furthermore, GLUT2 promoter activities in SGR, FGR and HCV-infected cells were restored by IFN treatment. It

is thus likely that HCV replication suppresses GLUT2 promoter activity, thereby decreasing GLUT2 mRNA levels.

3.7. Ectopically expressed GLUT1 or GLUT2 mediates increased glucose uptake in SGR, FGR and HCV-infected cells

We examined the possible effects of ectopically expressed GLUT1 and GLUT2 on glucose uptake in SGR, FGR and HCV-infected cells. Glucose uptake was significantly increased by ectopically expressed GLUT1 or GLUT2 in SGR, FGR and HCV-infected cells as well as in the control Huh-7.5 cells (Fig. 6D). It should be noted that, in this series of transient transfection experiments, only ca. 20% of the cells were ectopically overexpressing GLUT1 or GLUT2. These results collectively suggest the possibility that down-regulation