

日本人高齢患者における最高酸素摂取量推定式の評価

関根 紀子[†] 吉村 拓巳[‡] 南部 雅幸[†] 田村 俊世[†]

[†] 国立長寿医療センター研究所長寿医療工学研究部 〒474-8522 愛知県大府市森岡町源吾 36-3

[‡] 東京都立工業高等専門学校電子情報工学科 〒140-0011 東京都品川区東大井 1-10-40

E-mail: [†] {noriko, nambu, tamura}@nils.go.jp, [‡] yoshimura@tokyo-tmct.ac.jp

あらまし 本研究の目的は、広く用いられている American College of Sports Medicine (ACSM) による酸素摂取量推定式を日本人高齢患者に応用した際の精度について検討を加えることである。被験者は予備実験として行った自転車エルゴメータ負荷試験にて呼吸困難等を訴えた日本人高齢患者 21 名とした。自転車エルゴメータによる漸増負荷試験での最高酸素摂取量の測定値と、2 種類の ACSM 推定式による結果とを比較した結果、ACSM 推定式は日本人高齢患者において最高酸素摂取量を過大評価することが示された。この傾向は特に女性で顕著であり、日本人高齢患者に ACSM 推定式を用いる場合はこの点に注意する必要があることが示唆された。

キーワード 最高酸素摂取量, 日本人高齢患者, 酸素摂取量推定式, 自転車エルゴメータ

Do Equations for Predicting Peak Oxygen Uptake from the Cycle Exercise Test Apply to Japanese Elderly Patients?

Noriko ICHINOSEKI-SEKINE[†] Takumi YOSHIMURA[‡]

Masayuki NAMBU[†] and Toshiyo TAMURA[†]

[†] Department of Gerontechnology, National Center for Geriatrics and Gerontology
36-3 Morioka, Obu, Aichi, 474-8522 Japan

[‡] Department of electronics and information engineering, Tokyo Metropolitan College of Technology
1-10-40 Higashi-Ohi, Shinagawa-ku, Tokyo, 140-0011 Japan

E-mail: [†] {noriko, nambu, tamura}@nils.go.jp, [‡] yosimura@tokyo-tmct.ac.jp

Abstract Objective of this study was to examine the accuracy of predicting equations for peak oxygen uptake (VO_{2peak}) during cycle exercise test reported by the American College of Sports Medicine (ACSM) in Japanese elderly patients. Twenty-one elderly patients who complained of dyspnea during exercise at peak levels (50 to 200 W) were volunteered. We compared measured VO_{2peak} value and predicted VO_{2peak} values based on two different equations (GETP5 and GETP6). Our result showed that the ACSM equations (especially GETP6) overestimated VO_{2peak} values in Japanese elderly patients. In conclusion, when these equations are applied to Japanese elderly patients, the possibility of overestimating VO_{2peak} should be recognized.

Keyword Peak Oxygen Uptake, Japanese Elderly Patients, Oxygen Uptake Predicting Equation, Cycle Exercise

1. INTRODUCTION

Measurement of oxygen uptake (VO_2) with a cardiopulmonary exercise test provides an insight into the exercise tolerance of a patient, which in turn enables prescription of appropriate exercise therapy. Decreased peak oxygen uptake (VO_{2peak}), identified by the cardiopulmonary exercise test, is associated with various symptoms [1] and with mortality in patients with heart failure [2]. Aerobic capacity decreases at a rate of about 10% per decade in sedentary people after the age of 25 [3-5], and exercise testing is often used for diagnostic and prognostic purposes in this population [6-9]. Some studies involving cycle exercise indicated that the cardiac response to performed work in elderly

patients was adequate same as that in young people [10,11].

Although direct measurement of VO_2 is desirable, the cardiopulmonary test is not particularly patient-friendly; elderly patients are distressed by wearing a mask and breathing through a valve or a filter. To resolve such concerns, the American College of Sports Medicine (ACSM) proposed that estimation of VO_2 be made using a simple equation instead of the direct measurement of VO_2 [12]. The accuracy of the ACSM equations had been examined in healthy males [13] and females [14], and after that a newly revised equation has been proposed [15]. Though, elderly patients with less activity might not have the exercise capacity as same as active elderly

people.

Recently, the newly revised ACSM equation was reported to provide reasonable estimates of VO_{2peak} values at the peak exercise test work level in American elderly patients with heart failure [16]. However, it is unclear that these equations suit for Japanese elderly patients who have different physical constitution. In this study, we examined the accuracy of these VO_2 predicting equations in Japanese elderly patients.

2. METHODS

2.1. Subjects

The subjects in this study were outpatients of the Division of Cardiology, Chubu National Hospital. Twenty-one elderly patients (14 males and 7 females, mean age 72.24 ± 6.40 years) who complained of dyspnea during performed pre-exercise tests volunteered. The physical characteristics of the subjects are shown in Table 1. The Ethics Committee of Chubu National Hospital approved the experimental protocol. Voluntary written informed consent was obtained from all patients.

2.2. Exercise test

Subjects were familiarized with the testing environment and procedures during a screening visit. All exercise tests were performed on an electronically braked cycle ergometer (Examiner 400, Lode Medical Technology, Netherlands) in a thermally controlled environment; the room temperature and relative humidity were maintained $21-24^\circ\text{C}$ and $45-55\%$. There was 3 min of warming-up with unloaded pedaling after 10 min rest. Then the subjects performed a conventional exercise test. Each of the tests consisted of a ramp protocol starting at 0 W; the pedaling cadence was maintained at 60 rpm. The exercise intensity was determined by the individual physical characteristics of the subject as follows [17]: 5, 10, 15, or 20 W/min for males, and 5 or 10 W/min for females. Heart rate, V-lead ECG tracings (BIOVIEW 2000, NEC, Japan), and brachial arterial blood pressure measured by a pressure transducer (UK801, Baxter, USA) were continuously monitored during the exercise test. The exercise test was terminated either when the subject voluntarily discontinued or when they were unable to maintain a pedaling cadence more than 40 rpm [18]. The highest observed value of VO_2 was accepted as a reliable measured VO_{2peak} when a respiratory quotient was over 1.20. During the exercise period, the subjects respired through a facemask with an adjustable air cushion. Expired gases were monitored by an automated breath-by-breath system (Vmax29, SensorMedics, USA). Minute ventilation, VO_2 , and VCO_2 were calculated as whole-breath averages per each minute.

2.3 Prediction of VO_{2peak}

Estimate of VO_{2peak} values were derived from two different regression equations, reported in the ACSM's Guidelines for Exercise Testing and Prescription (GETP).

$$VO_{2, GETP5} = 2 (\text{work rate}) / M + 3.5 \quad \dots(1)$$

$$VO_{2, GETP6} = 1.8 (\text{work rate}) / M + 7 \quad \dots(2)$$

M is the subject's body weight, and these coefficients of 2 or 1.8 are the cost of pedaling against an external

Table 1 Physical characteristics of the subjects.

Sex	Age [years]	Height [cm]	Body weight [kg]
Male	71.57 ± 7.66	161.31 ± 5.81	50.49 ± 7.34
Female	73.57 ± 2.51	148.23 ± 6.11	50.17 ± 8.59

Table 2 Comparisons of measured and predicted peak oxygen uptake.

Sex	Measured	GETP5	GETP6
Male	14.68 ± 4.82	20.15 ± 7.44	$21.99 \pm 6.70^*$
Female	15.88 ± 2.57	$20.84 \pm 3.22^*$	$22.60 \pm 2.89^{**}$

* : $p < 0.05$, ** : $p < 0.01$, difference from measured value. Values are expressed as ml/kg/min, mean \pm SD.

Table 3 Correlation coefficient between measured peak oxygen uptake and predicted values.

Sex	GETP5	GETP6
Male	0.85	0.85
Female	0.32	0.32

vs. measured peak oxygen uptake

Table 4 Correlation coefficient between weight, peak workload and the error of the predicted peak oxygen uptakes.

Sex		GETP5	GETP6
Male	weight	0.40	0.39
	peak workload	0.84	0.77
Female	weight	-0.14	-0.10
	peak workload	0.96	0.94

load. GETP5 equation (1) has been in use for approximately 20 years. GETP6 equation is a revised equation that is based on recent studies; the GETP6 equation was produced in order to limit the inaccuracies in estimations of VO_{2peak} values that were considered to arise with use of the GETP5 equation [15]. VO_2 value is normalized by body weight and the VO_{2peak} value is estimated as a VO_2 value at the peak exercise work level.

2.4 Statistical analysis

One-way ANOVA was used to analyze differences between the measured and the predicted VO_{2peak} values. Significant *F* values were followed up with Scheffe's post hoc tests. The relationship between the measured VO_{2peak} value and the two predicted values was assessed using Pearson's correlation coefficient. A value of $p < 0.05$ was considered statistically significant. Single regression analyses were used to assess the strength of the relationship between the measured VO_{2peak} value and the predicted VO_{2peak} values obtained from the GETP equations.

3. RESULTS

The mean measured and predicted $\text{VO}_{2\text{peak}}$ values are given in Table 2.

Comparison of $\text{VO}_{2\text{peak}}$ values derived from either direct measurement or use of the prediction equations indicated that the results by use of GETP6 significantly overestimated the $\text{VO}_{2\text{peak}}$ values in both sexes (Table 2).

The $\text{VO}_{2\text{peakGETP6}}$ values were significantly higher than the measured values ($p < 0.01$) in both sexes. The error between the measured and the predicted $\text{VO}_{2\text{peak}}$ values tended to increase with the value of the peak workload, but did not significantly correlate with body weight (Table 4).

There were strong correlations between the measured and the predicted $\text{VO}_{2\text{peak}}$ values in males, but no significant correlation in females (Table 3). For the GETP5 equation, the regression equations were as follows: measured $\text{VO}_{2\text{peak}} = 4.72 + 0.52 \times \text{VO}_{2\text{peakGETP5}}$ ($r = 0.85$) for males, and measured $\text{VO}_{2\text{peak}} = 10.58 + 0.25 \times \text{VO}_{2\text{peakGETP5}}$ ($r = 0.32$) for females (Fig. 1). For the GETP6 equation, the regression equations were as follows: measured $\text{VO}_{2\text{peak}} = 1.49 + 0.58 \times \text{VO}_{2\text{peakGETP6}}$ ($r = 0.85$) for males, and measured $\text{VO}_{2\text{peak}} = 9.48 + 0.28 \times \text{VO}_{2\text{peakGETP6}}$ ($r = 0.32$) for females (Fig. 2).

4. DISCUSSION

Since there is less risk of falling during exercise testing, cycle ergometers are relatively inexpensive, require little space, are easy to handle, provide body weight support, and are safer than treadmills. These advantages are all important when elderly people perform an exercise test. The aim of this study was to examine the accuracy of predicted $\text{VO}_{2\text{peak}}$ values for cycle ergometer exercise in Japanese elderly patients. We compared directly measured $\text{VO}_{2\text{peak}}$ value with two ACSM equations (GETP5 and GETP6). Our result showed that the ACSM equations (especially GETP6) overestimated $\text{VO}_{2\text{peak}}$ values in Japanese elderly patients.

The $\text{VO}_{2\text{peak}}$ value predicted by GETP6 differed significantly from measured value in both sexes. Using the GETP5 equation, there was a significant difference between measured and predicted $\text{VO}_{2\text{peak}}$ values in females, but no significant difference in males. We consider that this overestimation was caused by the low correlation between body weight and the value of peak workload (male: $r = 0.62$; female $r = -0.18$). In general, peak workload and body weight show a correlation. However, there was no correlation between body weight and peak workload and there was no significant correlation between measured $\text{VO}_{2\text{peak}}$ and predicted values, especially in females. These uncorrelated relations might have caused overestimation.

Another reason of the overestimation might be body weight. In the report about the accuracy of the ACSM equation in American healthy males 19-39 year of age, the mean body weight of subjects was 78.2kg (range: 53.8-118.8kg) [13]. In the other report in young female, the mean body weight of the subjects was $62.7 \pm 8\text{kg}$ [14]. The body weight of our subjects was lower than that of those reports. Body weight of Japanese elderly patient, that is, the values of the denominator in ACSM equations were small. It was considered that body weight was one of a

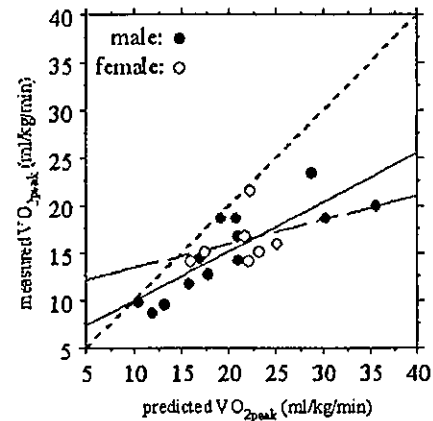

Fig.1 Relations between measured and predicted peak oxygen uptake from GETP5 equation.

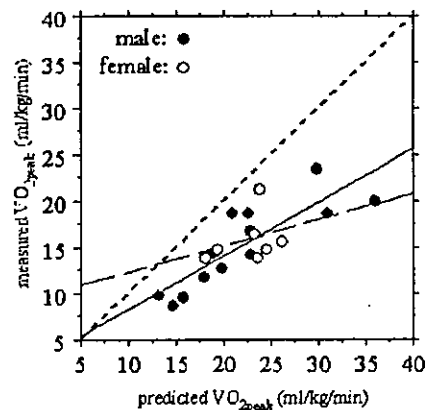

Fig.2 Relations between measured and predicted peak oxygen uptake from GETP6 equation.

factor effect on accuracy of ACSM equations, though the body weight of the subjects in our study were comparable to the mean body weight reported for the Japanese population [24].

The subjects continued exercise till the RQ value was over 1.20 and the measured $\text{VO}_{2\text{peak}}$ values were similar to previously reported values [16]. However in this study the error of $\text{VO}_{2\text{peak}}$ values were increased with increase of the workload, that is, VO_2 values did not increase with peak workload. There was a possibility that this uncorrelation was another reason of the overestimation.

Those findings in our study suggested that the methods for predicting $\text{VO}_{2\text{peak}}$ value need to be revised when it is applied to Japanese elderly patients, especially females. When ACSM equations are applied to Japanese elderly patients, the possibility of overestimating $\text{VO}_{2\text{peak}}$ value should be recognized.

5. CONCLUSION

In this study, we examined the accuracy of two VO_2 value predicting equations proposed by the American College of Sports Medicine in Japanese elderly patients. Our results showed that in Japanese elderly patients the ASCM equations overestimated $\text{VO}_{2\text{peak}}$ value. The equations for predicting $\text{VO}_{2\text{peak}}$ value need to be revised when it is applied to Japanese elderly patients, especially females. In conclusion, when these equations are applied to Japanese elderly patients, the possibility of overestimating $\text{VO}_{2\text{peak}}$ value should be recognized.

REFERENCES

- [1] DW Kitzman, "Heart failure in the elderly: systolic and diastolic dysfunction," *Am J Geriatr Cardiol* vol.5, no.1, pp.20-26, 1996.
- [2] SA van den Broek, DJ van Veldhuisen, PA de Graeff, ML Landsman, H Hillege, KI Lie, "Comparison between New York Heart Association classification and peak oxygen consumption in the assessment of functional status and prognosis in patients with mild moderate chronic congestive heart failure," *Am J Cardiol*, vol.70, no.3, pp.359-363, 1992.
- [3] ER Buskirk, JL Hodgson, "Age and aerobic power: the rate of change in men and women," *Fed Proc*, vol.46, no.5, pp.1824-1829, 1987.
- [4] GW Heath, JM Hagberg, AA Ehsani, JO Holloszy, "A physiological comparison of young and older athletes," *J Appl Physiol*, vol.51, no.3, pp.634-640, 1981.
- [5] ML Weisfeldt, The effect of aging on the cardiovascular response to dynamic and static exercise. *The Aging Heart*, Raven, New York, pp.269-296, 1980.
- [6] AL Clark, D Harrington, TP Chua, AJ Coats, "Exercise capacity in chronic heart failure is related to the aetiology of heart disease," *Heart*, vol.78, no.6, pp.569-571, 1997.
- [7] A Cohen-Solal, P Barnier, F Pessione, P Seknadji, D Logeart, T Laperche, R Gourgon, "Comparison of the long-term prognostic value of peak exercise oxygen pulse and peak oxygen uptake in patients with chronic heart failure," *Heart*, vol.78, no.6, pp.572-576, 1997.
- [8] H Itoh, K Taniguchi, A Koike, M Doi, "Evaluation of severity of heart failure using ventilatory gas analysis," *Circulation*, vol.81, 1suppl, pp.II31-II37, 1990.
- [9] DM Mancini, H Eisen, W Kussmaul, R Mull, LH Henry Jr, JR Wilson, "Value of peak exercise oxygen consumption for optimal timing of cardiac transplantation in ambulatory patients with heart failure," *Circulation*, vol.83, no.3, pp.778-786, 1991.
- [10] DR Seals, JM Hagberg, BF Hurley, AA Ehsani, JO Holloszy, "Endurance training in older men and women. I. Cardiovascular responses to exercise," *J Appl Physiol*, vol.57, no.4, pp.1024-1029, 1984.
- [11] MJ Sullivan, MB Higginbotham, FR Cobb, "Exercise training in patients with chronic heart failure delays ventilatory anaerobic threshold and improves submaximal exercise performance," *Circulation*, vol.79, no.2, pp.324-329, 1989.
- [12] WL Kenney, RH Humphrey, CX Bryant, "The American College of Sports Medicines Guidelines for Exercise Testing and Prescription Lippincott Williams & Wilkins, Baltimore 1995.
- [13] PB Lang, RW Latin, KE Berg, MB Mell, "Accuracy of the ACSM cycle ergometry equation," *Med Sci Sports Exerc*, vol.24, no.2, pp. 1992.
- [14] RW Latin, B KE erg, "The accuracy of the ACSM cycle ergometry equation for women," *Med Sci Sports Exerc*, vol.26, pp.642-646, 1994.
- [15] B Franklin, E Howley, M Whaley, "The American College of Sports Medicines Guidelines for Exercise Testing and Prescription 6th ed.," Lippincott Williams & Wilkins, Baltimore, p.304, 2000.
- [16] LA Kaminsky, PH Brubaker, B Peaker, DW "Prediction of peak oxygen uptake from exercise test work level in heart failure patients," *Am J Cardiol*, vol.85, pp.1385-1387, 2000.
- [17] K Wasserman, JE Hansen, DY Sue, R C "Clinical exercise testing. Principles of Testing & Interpretation: Including Pathophysiology and Clinical Applications 3rd ed.," Lippincott Williams & Wilkins, Philadelphia, p.130, 1999.
- [18] PO Åstrand, K Rodahl, "Body and fluids, blood circulation," *Textbook of Work Physiology*, McGraw-Hill, New York, p.132, 1986.
- [19] The Study Group on Information of Health and Nutrition, "Recommended Dietary Allowances and Dietary Reference Intakes 6th ed.," Iwanami Shuppan, Tokyo, p.11, 1999.
- [20] Statistics Bureau, Management and Coordination Agency, "Japan Statistical Yearbook 46th ed.," Statistical Association, Tokyo, 1996.

Development of the Sheet Matrix Thermometer for the Home Healthcare

Masayuki Nambu¹, Kazuki Nakajima², and Toshiyo Tamura³

¹Department of Gelontechnology, National Center for Geriatrics and Gerontology, Japan

²Faculty of Engineering, Toyama University, Japan,

³Faculty of Engineering, Chiba University, Japan

I. INTRODUCTION

In the clinical situation of the home care, 24 hours continuous monitoring of the health condition is necessary to prevent the disease of the subject became serious [1]. However, traditional medical monitoring system is very expensive, and very difficult to use for the elderly. Therefore, we have been proposed several biomedical measurement systems [2]-[4], which are implemented to the wall, ceiling, bed or furniture. These measurement systems can acquire several kind of information from the subject in the daily life, and they are not necessary to operate by subjects. In this paper we describe the sheet matrix thermometer.

II. MATERIAL and METHOD

As shown if fig. 1 and 2, we developed the sheet matrix thermometer. This matrix thermometer has 512 IC type thermometers, and all thermometers are connected serial. This matrix thermometer is waterproofed and inserted between the bed and sheet. Typical data is shown in fig. 3. Since the continuous measurement of the body surface temperature, we can diagnose the health condition of the subject, using the matrix thermometer. In addition, we can know the posture in the bed and the illegal getting up of the dementia patient.

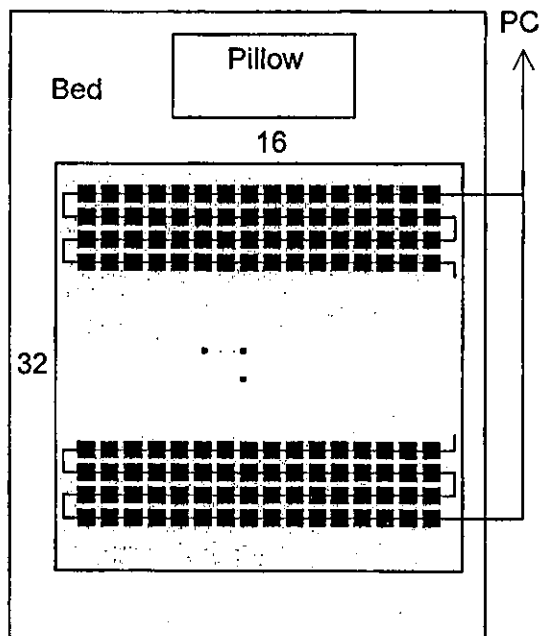

Fig. 2 Structure of Matrix Thermometer



Fig. 1 Sheet Matrix Thermometer

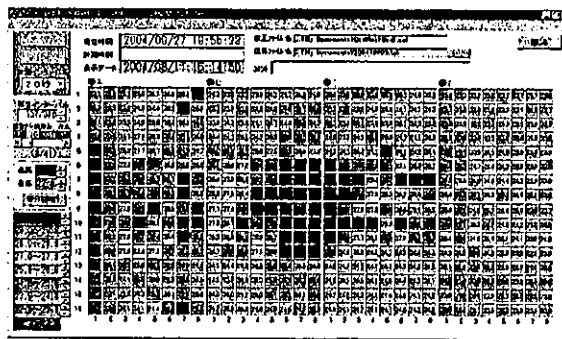

Fig. 3 Typical Data of Temperature in a Bed

However, real-time measurement of the posture is very difficult, because response of the temperature is sometimes very slow. Therefore, we propose the method to assume the posture, using image processing.

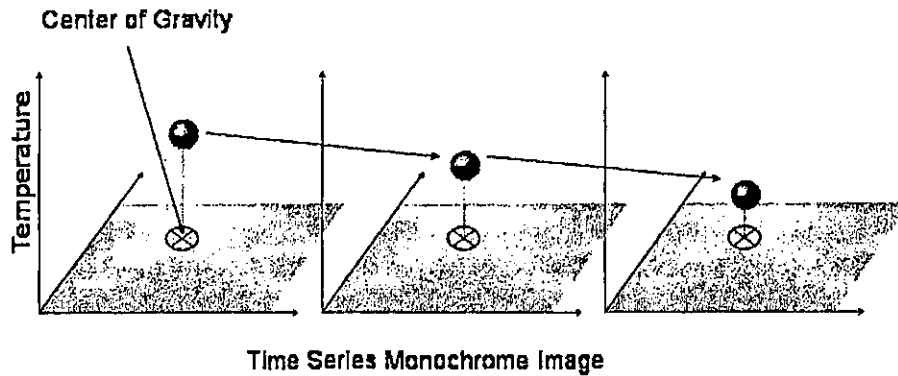

Fig. 4 Concept of Estimation of Posture in

The procedure of the processing as follows;

1. Reconstruct monochrome image from data of temperature.
2. Calculate the center of gravity of the image.
3. Set the brightness of the image at the center of gravity to the index.
4. Assume the posture using time series of the index and the center of gravity.

The center of gravity will be moved and the index will not be changed when the posture is changed. The center of gravity will not be changed and the index will be decreased when the subject get up.

III. EXPERIMENT

According to the suggested method, we had some preliminary experiment. Temperature of the body surface was observed about two degree lower than temperature of body on the average. We tried to detect the change of the posture and getting up. As shown in table I, we could detect almost events in three times of trial. Especially, we could detect all events of getting up.

Table I Result of Experiments

	Posture Change A	Posture Change B	Getting Up
Subject A	Detect	Detect	Detect
Subject B	Detect	Not Detect	Detect
Subject C	Detect	Detect	Detect

* The threshold was heuristically determined

IV. DISCUSSION

As the result of the experiment, we could detect the getting up of the subject from three frames of data. These data are corresponds to data of one minute. We consider that one minutes is enough short to prevent the accident like falling.

In this time, we determined the threshold for estimation of posture heuristically, because the result

depends on external factors such as environmental temperature. We should find the technique for excluding the influence of these external factors, in the future. Especially, sometimes center of gravity will be located on the outside of body, because exposed palm or ankle shows higher temperature. To resolve this problem, we should find new method that combines other information of image.

In addition, we could measure the posture of the subject using this thermometer, even if we do not use video camera. Therefore, we could measure the temperature and posture of the subject from outside the house via the Internet protecting privacy.

V. CONCLUSION

We developed the sheet matrix thermometer. We can measure not only the body surface temperature but also posture in the bed. In addition, we proposed the method to detect the change of posture. As the result of experiment, we could detect the getting up the subject.

REFERENCES

- [1] K. S. Park, et. al., "Ubiquitous Health monitoring in Normal Apartment style House", 43th Annual Conference of Japanese Society for Medical and Biological Engineering, Kanazawa, Japan, 2004.
- [2] T. Tamura, T. Togawa, M. Ogawa, M. Yoda, "Fully Automated Health Monitoring System", Medical Engineering & Physics, 20, 573-579, 1998
- [3] M. Nambu, K. Nakajima and T. Tamura, "An Algorithm for Evaluation of Health Condition in the Eldely", 2002 Japan Korea Symposium on e-Healthcare, Seoul, 2002
- [4] M. Nambu, K. Nakajima, and T. Tamura: WWW Based ECG Transfer for Home Care using JAVA Script, IEEE EMBS-BMES 2002, Houston, USA, 2002

Telecare system for home rehabilitation without PC

Toshiyo TAMURA¹ Yasushi MASUDA², Mitsuyoshi SEKIMOTO³, Masayuki NAMBU⁴,
Yuji HIGASHI³, Toshirou FUJIMOTO³

¹Chiba University School of Medicine ²Nara Institute of Science & Technology
³Fujimoto Hayasuzu Hospital ⁴National Institute of Longevity Science

Abstract : A simple telecare system for home rehabilitation using mobile phone has been developed. The system consists of a sensory system for the home and a viewer system (PDA) for the therapist. A TCP/IP network using various physical communication infrastructures connects the sub-systems. In the sensory system the heart and respiratory rates were measured and stored every one minute. Obtained data are transmitted to therapist PDA via mobile phone communication. Five bed-fasten patients were performed the test and the therapist could receive vital data subjects' health status remotely, anywhere and at any time.

I. INTRODUCTION

Advances in Information Technology and Telecommunications (ITT) have played a catalytic role in recent developments within the field of Assistive (Rehabilitation) Technology, facilitating the introduction of new products and services. The importance of ITT to elderly people cannot be over-stated. As well as everything else that a personal computer (PC) user takes for granted in this electronic age (communications and health information through the internet, smart houses and other applications.), an elderly person must also handle the PC as an ordinary telephone or mobile phone.

To avoid a complex handling of PC resulted in very restricted access to today's services and facilities, we have been developed a tele-health care for home rehabilitation without PC.

Rehabilitation by a home-visiting therapist plays an important role in home health care, as the service decreases the physical work load and risk on the part of patients who visit the hospital. The visiting therapist can also arrange exercises suitable for residential life. Post-exercise observations are also important. Therapists can ensure that patients are not over exerting themselves with the exercises and they can plan for, and evaluate, long-term rehabilitation schedules. At each observation, therapist acquires basic health data such as post-exercise heart-rate, respiratory rate, and blood-pressure. These diagnostics can be easily performed in a hospital setting. However, in home-visit rehabilitation, a therapist must usually visit a number of homes, making on-going information collection more difficult. While therapists can interview the subject or the subject's caregiver by telephone, the information collected is not quantitative.

For reasonable and effective operation of home-visit rehabilitation, a system that can monitor subjects' health remotely is essential. We have developed a system that uses mobile terminals to help with home-visit rehabilitation. The system allows a nomadic home-visit therapist to acquire subjects' health status remotely, anywhere and at any time.

II. METHODS

Figure 1 show the system structure.. The system consists of a sensory system for the home and a viewer system for the therapist. A TCP/IP network using various physical communication infrastructures connects the sub-systems.

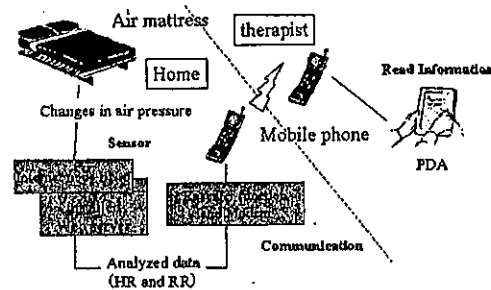

Figure 1 System structure

A. Home-side sensory system.

The home-side system consists of an air-filled mat, a sensory and analysis unit, and a bridge unit that handles connections. When a subject lies on the mat, the mat senses pressure from the subject's respiration or heartbeat.

Heartbeat or respiration disturbances have robust frequency characteristics, with a relatively low frequency in relation to environmental noise. Thus, by applying an appropriate filter, readings can be extracted to estimate respiratory and heart rates.

The analysis unit (Bio-Sensor Node BN-6, Yokogawa Electric Corp.) continuously monitors pressure perturbations with a pressure sensor and estimates rates for predefined timeframes. Estimates are stored in a built-in web server system in HTML format, accessible via an integrated Ethernet interface. An embedded microserver unit (OpenBlockSS, Plat Home Inc.) serves as the bridge unit.

In communication line, we decided to employ a wireless network using mobile phone terminals for both ends of the

connection. A wireless network also resolves the issue of cost and responsibility, since hospitals would not have to provide phone terminals. In our system, a mobile phone modem (MobileDP 2496P, NTT DoCoMo Corp.) connects the bridge unit and a mobile phone.

B. Therapist-side viewer system

Therapists would access the home-side sensor node to browse a subject's status and could quickly check various patients. To track or record long-term transitions in health status, the system would have to store and arrange acquired information.

Since therapists do not necessarily have expert computer knowledge, the viewer system should have a simple interface that does not require special knowledge for setup, browsing, or reporting. We therefore developed a viewer system using a personal digital assistant (PDA) and a mobile telephone. Today's PDAs have web access via popular web-browser interfaces, as well as simple text-editor functions suitable for making reports. An infrared modem links the PDA and the mobile phone.

C. Subjects

We operated the system in real patients' homes to evaluate its potential. We conducted the testing in Miyazaki Prefecture, Japan. A therapist from Fujimoto Hayasuzu Hospital and five residential patients joined in the experiment. Prior to the experiment, the hospital's ethics council ensured that the patients and their families had given both oral and written informed consent.

The system was placed in a briefcase for easy installation. Prior to the experiments, the therapist was given brief instructions on system installation and use. After the training, the therapist could install the system in five minutes.

The therapist used the PDA system to measure heart and respiratory rates anywhere and anytime the therapist wants.

III. RESULT

Figure 2 shows a typical examples of data. Each operation took approximately 2 minutes, including about 40 seconds for HTTP data transmission. Although radio wave malfunctions caused several lost connections, the system recovered easily by reloading via the web browser. The therapist used each measurement to check the patient's stability. Results were stored in a text document on the PDA to log transitions in the patient's status. Figure 6 shows the measurement results. In each case, although heart and respiratory rates increased immediately after training, the increased rates were considered safe and the subject recovered in 30 minutes.

IV. DISCUSSION

In all five cases examined above, the system successfully obtained data on patient status. Because we simplified the system structure so that the therapist needed

only to plug in to start or stop the system, the time and cost for installation and maintenance were appropriate for our needs. Patients also approved of the system's compact, silent, and non-constraining nature. Patients especially valued the non-constraint. Unlike systems that require patients or their caregivers to set up complicated devices, our system merely had patients rest on their bed or futon.

We used a personal digital cellular (PDC) mobile telephone for data transmission. The phone requires a relatively low bandwidth (9600 bits/sec), and since we had limited the information sent to less than 50 kilobytes, transmission took a maximum of one minute to download. Recently, bandwidth for mobile phones has been improving. For example, wide-band code division multiple access (W-CDMA) has 384 kilobits/sec of bandwidth. Thus, it is possible to provide faster access. By providing data via web interfaces, the operations for browsing and editing results were easily understood by user. With each measurement, the therapist could confirm that the patients had not suffered overloading shock from the exercises. Also, the logged data showed that patient status safely transitioned back to normal following exercise. The exercise training loads for both patients proved appropriate. While it is difficult to evaluate post-exercise transitions by interviews, our system can provide quantitative information for evaluation.

The quantitative data can be used not only for training evaluation but for preventive medicine and quality control of home-visit rehabilitation services through long-term observations. Our test also suggest the efficiency of low-bandwidth, which can provide an ubiquitous framework for home health care use.

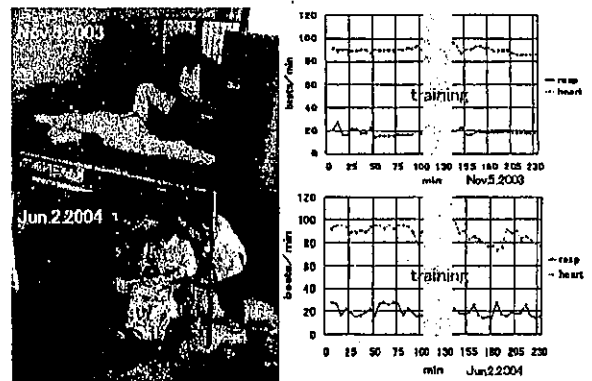

Figure 2. A typical example of the HR and RR

ACKNOWLEDGEMENTS

This work was partly supported by the New Energy Development Organization (NEDO H14-0603001). Measurements were conducted by the Rehabilitation Center, Fujimoto Hayasuzu Hospital, Miyazaki, Japan. Yokogawa Electric Corp. and Internet Node Inc. supported the Bio-Sensor node.

An Internet mobile phone-based "HOME HELPER" support system

Hidekuni Ogawa¹, Yoshiharu Yonezawa², Hiromichi Maki³
Haruhiko Sato⁴ and Toshiyo Tamura⁵

¹Department of Information and Intellectual Systems, Hiroshima Institute of Technology, Hiroshima 731-5193, Japan.

²Department of Electronics, Hiroshima Institute of Technology, Hiroshima 731-5193, Japan.

³Department of Clinical Engineering, International Trinity College, Hiroshima 730-0014, Japan

⁴Department of Human Living System Design, Faculty of Design, Kyushu University, Fukuoka 815-8540, Japan.

⁵Department of Biomedical Engineering, Chiba University, Chiba 263-8522, Japan

Abstract— A Home Helper support system has been developed for improving care efficiency. The system consists of a conventional telephone at care-requiring client's homes, a server computer at the Home Helper office and a Java mobile phone for each Home Helper. The care requests are sent from care-requiring clients to the server computer by voice via a conventional telephone. The server computer employs a computer telephony board (CT board) as a telephone interface. The CT board detects the name of the care-requiring client from their telephone number. The server computer records the care-requiring client's voice by a method similar to an answering machine and automatically stores the request as a wave file for 30 s. Then the information transfers to the Home Helper's Java mobile phone by e-mail. The Home Helper can check their requests by voice before visiting. This newly-developed support system is easily operated by care-requiring clients.

Keywords—Home Helper, Java mobile phone, Care efficiency, Communications.

I. INTRODUCTION

A long-term care insurance law for care-requiring clients was put in force four years ago. The Home Helpers are employed by hospitals, care companies or the welfare office, and are sent to the homes of care-requiring clients to provide home welfare and care services such as cooking, bathing, washing, cleaning, shopping, etc. The Home Helpers are required to make their reports on the computer at the employment office after the care visits. This process requires a significant amount of time and extra travel. We recently reported the development of the web-based Home Helper support system using wireless Internet mobile phone service [1,2]. The system can send care reports directly from the care-requiring client homes to the office server computer via Internet. However the care items, which are scheduled for one month before the care visit, are often changed suddenly by request from the care-requiring client, and the Home Helpers need to know these changes as soon as possible.

In this study, we developed an Internet Java mobile-based "home helper" support system, which enables faster communications between the care-requiring clients, care manager and the Home Helper for improvement of care efficiency.

II. SYSTEM DESCRIPTION

Figure 1 shows the overall Internet Java mobile-based "Home Helper" support system. The system consists of a

conventional telephone at the care-requiring client's home, a server computer at the Home Helper office and a Java mobile phone for each Home Helper. The care requests are sent from care-requiring clients to the server computer by voice via a conventional telephone. The server computer employs a computer telephony board (CT board) as a telephone interface. The CT board detects the name of the care-requiring client from their telephone number. The server computer records the care-requiring client's voice by a method similar to an answering machine and automatically stores the request as a wave file for 30 s. Then the information transfers to the Home Helper's Java mobile phone by e-mail. The Home Helper accesses the server computer with the Java mobile phone, and the request is confirmed by voice via the server computer before visiting.

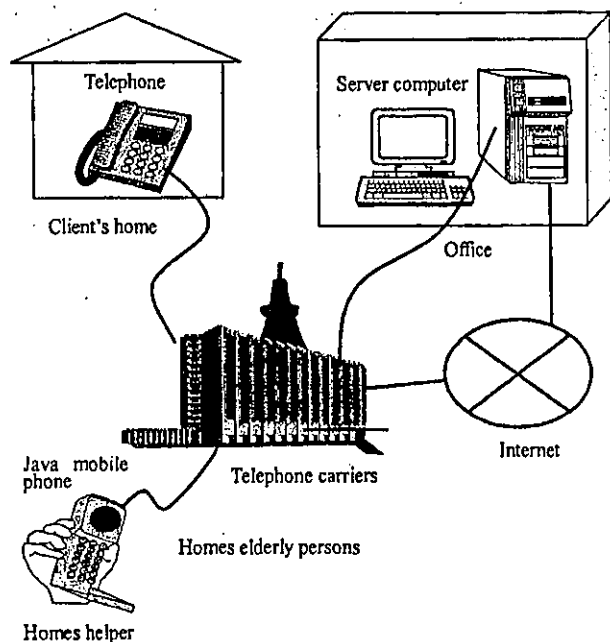

Fig. 1 The overall Internet Java mobile-based "Home Helper" support system.

III. SYSTEM EXPERIMENTAL TRIAL

Figure 2 shows the experimental trial system for measurement of communication time from conventional telephone at care-requiring client's home to the Home Helper's Java mobile phone. The mobile phone used is an i-Apri (F503i, NTT DOCOMO Japan). The server computer used is a conventional Pentium III 1GHz Windows computer with 512 Mbyte memory, 40 Gbyte HDD and 100 base-T Ether LAN adapter. The communication time after the called request was recorded for 24 hours at intervals of one-hour, as often the communication time is influenced by congestion of internet communication. The recorded time contains the voice recording time of 30 seconds.

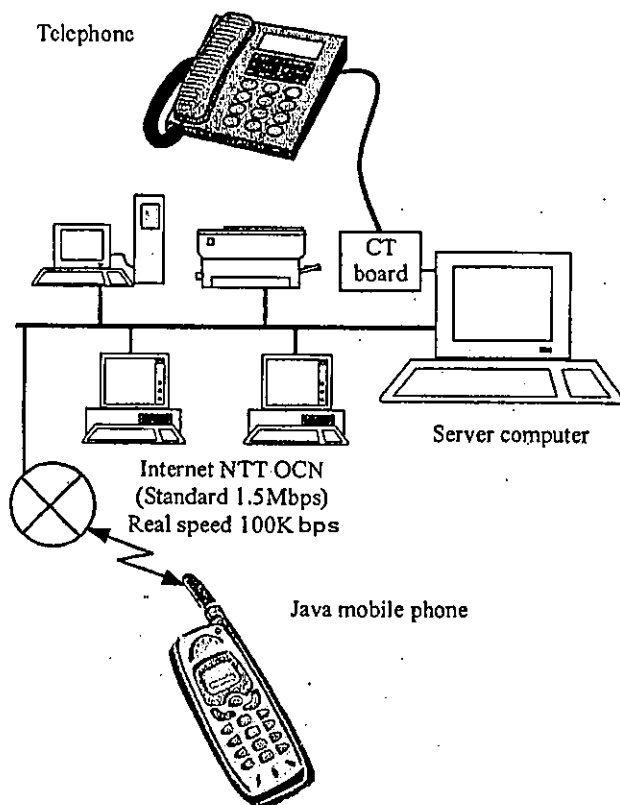

Fig. 2 The trial experimental system over view.

IV. RESULT

Figure 3 shows the communication time, except for the 30 second voice recording period. The maximum and minimum communication times were 54.3 seconds and 9.3 seconds, respectively. The average communication time was 20.8 seconds. The server computer takes only 1

second to create the file. Therefore, this system can create the file and transfer the information in almost real time. It must also be considered that the communication time range was influenced considerably by the congestion conditions of the telephone and internet systems, which vary with time of day.

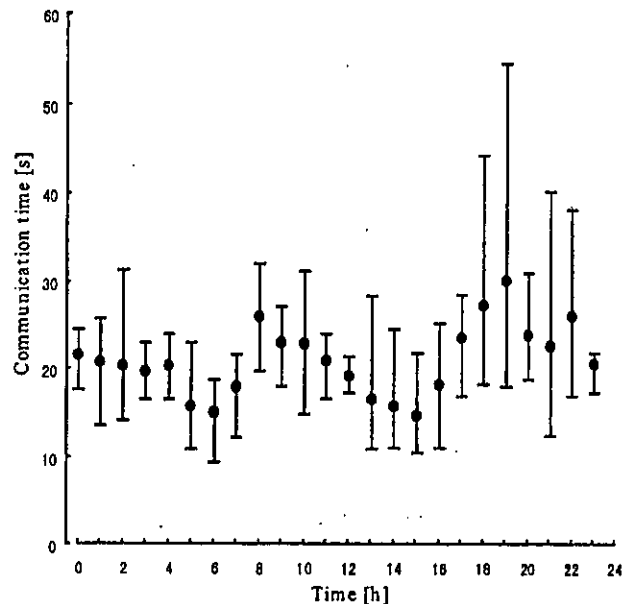

Fig. 3 The communication time recorded for 24 hours.

V. CONCLUSION

The developed system consists of standard telephones, Java mobile phones and a desktop computer, and does not require any specialized equipment. The care-requiring clients can easily operate the developed system and send their requests to the Home Helper and care manager via the server computer at any time, day or night. Therefore, the system improves care efficiency by enabling faster communications between the care-requiring clients, the care manager and the Home Helpers.

REFERENCES

- [1] Hidekuni Ogawa, Yoshiharu Yonezawa, Hiromichi Maki, "Home Helper Support System Using a Wireless Internet Mobile Phone", *The Japanese Journal of Medical Instrumentation*, Vol.71, No.8, pp.373-379, 2001.
- [2] Hidekuni Ogawa, Yoshiharu Yonezawa, Hiromichi Maki, Allen W. Hahn, and W. Morton Caldwell, "A Web-Based Home Helper Support System", *Biomedical Sciences Instrumentation*, Volume 37, pp.95-99, 2001.

麻痺患者における床材質の立ち上がり一歩行動作に及ぼす影響に関する検討

Investigation of the influence of floor material on standing-walking motion in hemiplegic patients

関根正樹¹, 田村俊世¹, 吉村拓巳², 桑江 豊³, 東 祐二⁴,
湯地忠彦³, 藤元登四郎³, 山越憲一⁴

Masaki SEKINE¹, Toshiyo TAMURA¹, Takumi YOSHIMURA², Yutaka KUWAE³,
Yuji HIGASHI⁴, Tadahiko YUJI³, Toshiro FUJIMOTO³, Yamakoshi KENICHI⁴

¹ 千葉大学, ² 東京都立工業高等専門学校, ³ 藤元早鈴病院, ⁴ 金沢大学

¹ Chiba University, ² Tokyo Metropolitan College of Technology,
³ Fujimoto Hayasuzu Hospital, ⁴ Kanazawa University

Abstract In this study, we attempted to evaluate the influence of floor material on standing and walking in hemiplegic patients. A triaxial accelerometer was fixed on the subject's back to measure the body motion during standing and walking. 11 patients executed the modified TIME UP&GO TEST on two different floor materials including wooden flooring and carpet. After recordings were done, the acceleration signals were divided into movement and postural components using the high- and low-pass filters, respectively. As a result, the non independent patients spent much time for standing and walking on carpet compared to wooden flooring. Therefore, it was suggested that the body motion was influenced on the floor material.

1. はじめに

脳卒中予後の片麻痺患者において、立位から歩行を獲得する課程が重要である。そのなかで環境因子、特に床面の違いにより立位や歩行が困難になる場合がみられる。そこで、本研究では、床面の材質が片麻痺患者の立ち上がり一歩行動作に与える影響をについて検討した。

2. 方法

2.1 測定装置

立ち上がり動作と歩行動作の測定に用いた3軸加速度計は、ピエゾ抵抗型加速度センサ(Akebono Brake社, 定格加速度±2g, 周波数応答 DC-200Hz)とアンプを含み、外形寸法は30×40×20mm, 重量25gである。加速度計からの信号は、カットオフ周波数50Hzのフィルタ回路とマルチテレメータシステム(WEB-5000, 日本光電)を介し、パーソナルコンピュータにサンプリング周波数128Hzで記録した。マルチテレメータシステムの送信機の寸法は128×80×28mmであり、重さはおよそ300gである。

2.2 測定方法

測定対象者は、外来または入院中の11名の片麻痺患者とし、6名はT字杖とプラスチック短下肢装具を使用して平地を自立レベルにて歩行可能であり(自立群, 年齢56±4歳, 罹患期間22±15ヶ月, Br.stage III:2名, IV:4名), 残りの5名は歩行監視レベルであった(監視群, 年齢70±13歳, 罹患期間3.8±1.1ヶ月, Br.stage III:3名, IV:2名)。

測定課題は、podsiadleらによって紹介されたTIME UP & GO TESTに基づいた課題とし、手順は以下の通りである。

- i) 被験者は肘掛け椅子(シート高さ:460mm)の背もたれに背をつけて座る。
- ii) 被験者は、検査者の合図で立ち上がり歩行を開始し3m先に用意した椅子に座る。

測定は、加速度計を対象者の腰背部(第2腰椎近傍)に装着し、フローリングとポリプロピレン製カーペットの2種類の床材質上で施行した。

2.3 解析方法

加速度計で得られる信号は、運動による加速度だけではな

く、姿勢(傾斜)変化にともなう静的な加速度も包含する。そこで、ハイパスとローパスフィルタを用い運動成分と姿勢成分を分離し、それぞれの成分から立ち上がり動作と歩行動作を解析し評価した。なお、本研究では成分を分離するフィルタに4次のバターワースフィルタを用い、周波数帯域をそれぞれDC-0.2Hz, 0.2-4Hzに設定した。また、姿勢成分については、重力加速度との関係から(1)式により角度に換算した。

$$y = \text{asin}(x/g) \quad (1)$$

ここで、xは加速度の姿勢成分、gは重力加速度、yは角度に換算された姿勢成分である。

2.3.1 動作の分類

座位や立位、歩行を維持する際の姿勢は、立ち上がり動作のような過渡的な動作に比べるとほぼ一定の角度であると考えられる。そこで、姿勢成分が顕著に変化する範囲を立ち上がり動作と着席動作とし、その間を歩行動作として分類した。

2.3.2 動作の評価

立ち上がり動作に関しては、姿勢成分から立ち上がりに要した時間と最大の前傾角度について評価した。

歩行動作に関しては、姿勢成分から歩行時間、運動成分から規則性と矢状面における加速度のRMSについて評価した。なお、規則性については、Pincusによって提案された信号の統計的な規則性の指標であるApproximate Entropy(以下ApEn)を用いた[1]。

3. 結果

測定課題(座位一歩行一座位)における自立群と監視群の典型的な運動成分と姿勢成分をFig.1とFig.2に示す。運動成分(Acc)におけるX, Y, Zの正の値は前方向, 左方向, 上方向である。また、姿勢成分(Ang)におけるX, Yの負の値は前傾, 左傾を示す。Fig.1とFig.2の前後方向の姿勢成分(Ang_x)から体幹が立ち上がり動作と着席動作の際に大きく前傾していることが観測された。そこで、立ち上がり動作と歩行動作の分類にAng_xが立ち下がる時刻と安定状態に達する時刻を用いた。

各群における立ち上がり動作に要した時間と最大前傾角度、歩行路3m間の歩行時間、RMS, ApEnをTable 1とTable 2に示す。フローリングとカーペットでの動作の差異に関して、

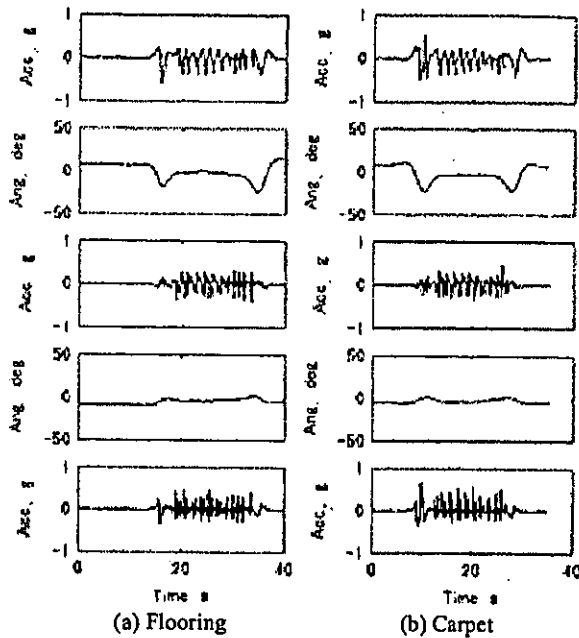

Fig.1 Typical examples of movement components (Acc) and postural components (Ang) in a left-hemiplegic patient who could walk independently. X, Y and Z indicates the anteroposterior, lateral and vertical directions, respectively.

Table 1 Mean and standard error of the evaluation parameters for independent-walking patients group

		Flooring	Carpet
Standing	Duration s	5.83 ± 0.42	6.26 ± 0.56
	Max forward-leaning angle deg	13.25 ± 1.42	17.49 ± 1.53
Walking	Duration s	11.55 ± 1.86	13.76 ± 1.40
	RMS mg	99.26 ± 9.75	102.56 ± 8.71
	ApEn	0.19 ± 0.01	0.18 ± 0.01

自立群の被験者 6 名中 5 名以上の被験者で同様にみられた傾向は、カーペットにおいて立ち上がり動作時の前傾角度の増加、歩行時における運動成分の RMS の増加と規則性の増加 (ApEn の減少) であった。一方、監視群では、カーペットでの立ち上がり動作時間と歩行動作時間の増加、RMS の減少が被験者 5 人中 4 名以上にみられた。

4. 考察

本研究では、フローリングとポリプロピレン製カーペットの 2 種類の床材質が片麻痺患者の立ち上がり動作と歩行動作に与える影響について、加速度計を用いて評価した。

2 つの床材質の大きな差異は硬度であると考えられる。硬度が低い床面において動作を遂行すると足底面が沈み込み、硬度の高い床面に比べて反力が得られにくい。このため、自立群の片麻痺患者では姿勢をより前傾にすることで立ち上がり動作に必要な反力を補ったものと考えられる。しかしながら、監視レベルの片麻痺患者では反力が得にくい環境下での姿勢制御が十分に行えないため、過度の前傾姿勢にならないよう時間を掛けて立ち上がり動作を遂行すると推測された。実際、立ち上がり動作時の前後方向の姿勢成分 (Ang_x) は、滑自立群やフローリング上では滑らかな 1 つの谷を描くのに対して、カーペットでは Fig.2(b) のように動作に費やす時間が長く、前傾を数回繰り返すパターンがみられた。

一方、カーペットでの歩行動作は、立ち上がり動作と同様

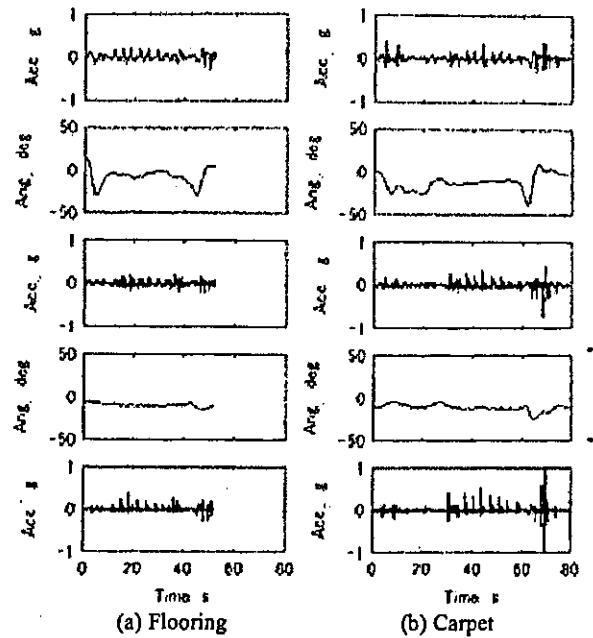

Fig.2 Typical examples of movement components (Acc) and postural components (Ang) in a right-hemiplegic patient who could walk under surveillance. X, Y and Z indicates the anteroposterior, lateral and vertical directions, respectively.

Table 2 Mean and standard error of the evaluation parameters for non-independent-walking patients group

		Flooring	Carpet
Standing	Duration s	7.82 ± 0.48	11.99 ± 2.79
	Max forward-leaning angle deg	22.33 ± 3.15	22.74 ± 2.02
Walking	Duration s	48.98 ± 23.53	59.24 ± 28.95
	RMS mg	71.97 ± 11.55	68.89 ± 11.89
	ApEn	0.21 ± 0.02	0.21 ± 0.02

に反力が得にくく、フローリングを同等の歩行速度を維持するためには、駆動力を増加させる必要がある。運動成分の RMS は駆動力に関連するパラメータであり、歩行自立群では増加する傾向がみられた。しかし、その RMS は監視群では減少し、フローリングに比べ歩行動作時間が長く、つまり歩行速度が低下していた。これは、運動パターンの規則性 (ApEn) が低下していないことから、監視群では速度よりむしろ安全性を優先したものと推測される。

今後、被験者数を増加し統計的な検定を行う必要があるが、今回の実験において各群 8 割以上の被験者に同様な床材質の影響がみられた。このことから、片麻痺患者、特に歩行が監視レベルの患者においては装下器具だけではなく床材質も考慮する必要があると示唆された。

謝辞

本研究の一部は、笹川科学研究助成ならびに平成 15 年度長寿医療委託費 (15 公-4) による。

参考文献

- [1] S. M. Pincus: Approximate entropy as a measure of system complexity, Proc Natl Acad Sci USA, 88, 2297-301, 1991.

テレメータ型加速度モニタリングシステムの開発とその応用

The development and application of the telemetry acceleration monitoring system

吉村 拓巳¹, 関根 正樹², 田村 俊世²
Takumi YOSHIMURA¹, Masaki SEKINE², Toshiyo TAMURA²

¹東京都立工業高等専門学校, ²千葉大学
¹Tokyo Metropolitan College of Technology, ²Chiba University

Abstract The aim of this study is to develop the telemetry acceleration monitoring system. In this research, we developed the telemetry system to evaluate the action of the subject to use an accelerometer. We designed the system with low power consumption and we evaluated battery life. The system must be small, light and able to be worn without discomfort. The monitor consists of accelerometer, CPU and transmitter that the acceleration waveform to a receiver. The monitor is 7×4×1.5 cm in size and 50 g in weight. The system was designed to operate without doing any complex setting. The tri-axial acceleration sensor was used to measure the movement of the subject. The acceleration waveforms were converted to digital data in 10-bit resolution. The received data were transferred to the personal computer using a RS-232C interface. The developed system was attached to the younger healthy subject, and the mimicking fall was carried out. The zero gravity could be observed around 100 to 200 ms before falling down completely. As a result of the evaluation, we found that the detection time was too short to prevent the falling injury.

1. まえがき

近年の食生活や生活環境の変化, 医療技術の進歩などにより日本人の平均寿命は増加し, 先進国でも高い水準を維持している。このような状況の中, 今後は健康に長生きできる社会を実現することが重要な課題となっている。平成 16 年度版の厚生労働白書においても, 「健康寿命」の延伸が重要な課題であることが示されている。

「健康寿命」の延伸を行う一つの方策として「寝たきり」の防止があげられる。「寝たきり」になる要因としては転倒やベッドなどからの転落があげられる。これら転倒や転落などの事故を未然に防ぐには, 高齢者の行動や歩行を解析し, 得られた情報から事故防止を行うことが必要である。さらに, 万が一転倒転落した場合にエアバッグなどにより被害を軽減するシステムが必要となる。これには, 高齢者の行動や歩行の状態, 転倒や転落の情報などをリアルタイムに計測する必要がある。

従来, 歩行状態や転倒時の情報を工学的に計測する方法として加速度センサが用いられている。これらの研究は加速度センサを身体に装着し, パーソナルコンピュータ等に加速度波形を保存する手法が一般的であるが, 汎用の装置を組み合わせるため, 装置が高価でシステムが大型化する傾向がある。また, 小型の装置を用いて転倒を計測可能な装置の開発[1]も行われているが, 転倒前後の加速度波形の計測のみで, 連続的に加速度波形を計測することはできない。さらに, PC カードに加速度波形を保存可能な加速度モニタの開発[2](シャープ(株))も行われているが, 解析をオフラインで行うため, リアルタイムに波形を解析することはできない。

このような問題点を解決するため, 筆者らは, テレメータ通信により加速度波形を連続的に計測可能な小型モニタの開発を行ってきた[3]。しかし, 開発したモニタは電池寿命が短く, 十分な計測が困難であった。ここでは, 電池寿命の長期化を試み転倒の予防に用いることが可能かを検討した。開発したシステムは主に高齢者に対して, 日常行動や歩行状態の計測, 転倒・転落防止の解析に使用可能であることを目的とし, その応用として, 万が一転倒が発生したときエアバッグを膨らませるなどの対策が可能かを検証した。

2. 加速度モニタリングシステムの開発

2.1 システムの基本概要の決定

従来, 日常行動の計測や歩行解析にはカメラを用いた研究や, 赤外線センサなどを用いた研究, 加速度計を用いた研究などが行われている。カメラを用いた研究[4]では, カメラの画像から片麻痺患者の歩行状態を評価している。この方法は無拘束で計測が可能であるが, カメラの範囲内でしか計測ができないという問題点がある。赤外線センサを用いた研究[5]では居室内に複数のセンサを設置し, 高齢者の行動解析を行っている。これらの研究はセンサの範囲内であれば行動を把握可能であるが, 歩行状態や転倒・転落などの情報を詳細に解析することは困難である。加速度センサを用いた研究では, データロガー等により加速度波形を計測し, 姿勢情報や行動を推定する研究[6-8]や, 加速度波形から歩行状態を推定する研究[9-12]などが行われている。加速度波形を計測する方法はセンサが小型であるため比較的簡便に計測可能である利点がある。

本研究では簡便に歩行や転倒の計測が可能で、かつ比較的多くの解析が行われている加速度波形をリアルタイムで計測・解析可能な機器を開発することにした。装置に要求される仕様としては、高齢者に装着するため小型軽量で装着の負担にならないことが望まれる。従来、リアルタイムに加速度波形を計測するには、センサから有線でA/D変換ボード等に入力する必要があったが、自由に行動できないという問題点があった。本研究では日常的な行動を計測するため、無線テレメータにより波形を送信する方法を採用した。また汎用性を持たせるためには、有線方式でデータを出すことも可能で、加速度以外のアナログ入力やデジタルIO信号も入力可能であることが望ましい。上記の検討点を考慮しシステムの設計を行った。

2.2 システムの開発

システムの構成図を Fig.1 に示す。開発したシステムは加速度送信機、受信機、パーソナルコンピュータから構成されている。送信機内で直接A/D変換を行い、デジタルデータを受信機に送信することで、ノイズの少ない計測を行うことが可能である。

Fig.2 に開発した加速度送信機のブロック図を示す。送信機は加速度センサ、増幅器、CPU、無線ユニットから構成されている。加速度センサには3軸加速度計(AS3-001, 曙ブレーキ)を採用した。本研究で採用した加速度センサは、ピエゾ抵抗型のセンサで、重力加速度も計測可能であるため、被験者の姿勢情報も解析可能である。加速度センサからは $10[m/s^2]$ あたり約 $10[mV]$ の電圧が出力される。この信号を動作アンプで増幅し、フィルタを通してCPUに入力する。CPUは16bitマイコン(H8-3048F, HITACHI)を用いた。CPUにはA/D変換器、ROM、RAM、シリアルポート(SIO)、パラレルポート(PIO)等が内蔵されており、増幅部から出力される加速度波形を10[bit]でA/D変換する。変換速度はプログラムにより最高128[Hz]まで設定が可能である。変換された信号はシリアルポートにより無線送信ユニット(WMF-T30, Mitumi)に送られる。無線ユニットではデジタルデータをスペクトル拡散方式により受信機に通信速度19200bpsで送信する構成となっている。また、汎用性を持たせるため、外部コネクタを装備し、アナログ、デジタル信号を3チャンネル入力可能となっている。さらに、外部から有線で信号を送受信できるように、シリアル入出力端子も備えている。現在は加速度センサからの信号をそのまま送信するだけである。しかしCPUのプログラムを自由に書き換えることが可能であるため、たとえば、CPU内で波形の解析を行い、転倒や転落の危険があ

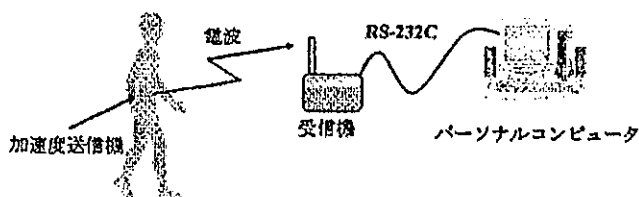

Fig.1 The experimental setup of developed system.

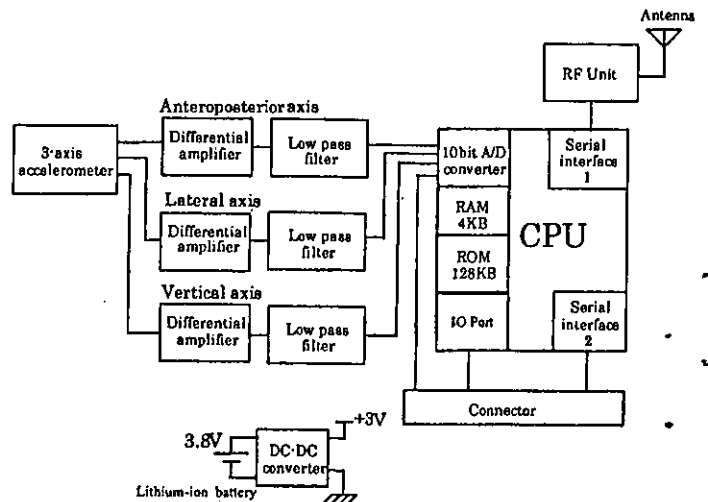

Fig.2 The The block-diagram of transmitter.

るときにだけ送信機や接続した機器に信号やデータを送ることも可能である。電源部にはリチウムイオン電池(IML270330-2, NEC Mobile Energy)を採用した。電池は送信機内に内蔵し、外部コネクタにACアダプタをつなぐことで充電可能な構成とした。これにより電池交換の必要がなく、1回の充電で約8時間の連続動作が可能である。Fig.3に送信機の外観を示す。装着の負担にならないように筐体には市販の徘徊検知機器(FH-MS, Aihon)のケースを加工して使用した。このため、突起部がなく装着の際にも違和感を与えない構成となっている。外形寸法は $7 \times 4 \times 1.5[cm]$ で重量は約50[g]と小型軽量である。受信機は無線受信ユニット(WMF-R30, Mitumi)を内蔵しており、受信した信号をシリアルデータに変換する。変換されたシリアルデータはRS-232Cインターフェースによりパーソナルコンピュータに転送する構成となっている。転送された波形はMATLAB(The Math Works Co.)を用いてリアルタイムに波形の表示や保存が可能な構成とした。Fig.4に表示画面を示す。従来のデータログのように装置本体にメモリを持たないため、小型軽量にすることが可能であった。

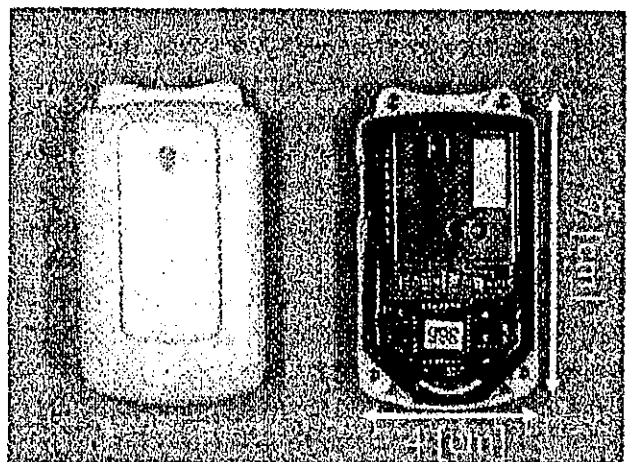

Fig.3 Externals of transmitter.

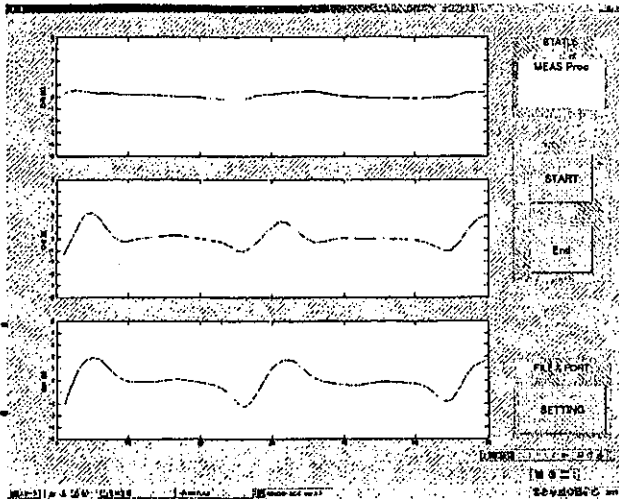

Fig.4 The display software of acceleration waveform.

3. 実験方法

転倒・転落による外傷の軽減を図るためには、転倒などの際にエアバッグを動作させるなどの緊急対策を行うことが有効であると考えられる。それには、事前に転倒の予兆を検出することが不可欠である。そこで本研究では開発したシステムを用い、加速度波形から転倒前の予兆を検出可能かの検討を行った。

通常、日常生活中は足裏や体の一部が床などに接地している。この際、身体は鉛直方向に重力加速度を受ける。従って、被験者に加速度計を装着した場合、重力加速度を検出可能である。しかし、転倒や転落の場合は身体の支えがなくなり、短時間では自由落下に近い動作をしていると考えられる。このため、加速度計は3軸すべての出力が $0[m/s^2]$ になると予想される。この予想をもとに、転倒による衝撃が加わる前に転倒中の状態を検出可能かを検討した。

健康成人男性 6 名(25.5±5.7[歳], 62.3±4.0[kg], 173.3±4.8[cm])を対象に疑似転倒の実験を行った。実験に際し、被験者には実験内容を説明し、書面にて同意を得て行った。疑似転倒は危険のないよう、マットレス上に自ら倒れることとした。転倒は直立の状態から前方に倒れる動作を各被験者あたり 3 回行った。計測データより、3 軸の出力がすべて $\pm 3[m/s^2]$ 以下となった場合を自由落下と定義した。

4. 結果

測定波形の一例を Fig.5 に示す。計測で用いた加速度センサは重力加速度を計測可能であるため、転倒による衝撃加速度と姿勢変化による直流成分のオフセット変化が得られる。身体の傾斜出力は前後方向は前方に傾斜した場合をマイナス、後方に傾斜した場合をプラスと定義した。さらに左右方向は右に傾斜した場合をマイナス、左に傾斜した場合をプラスとした。上下方向は傾斜方向に関係なく、身体が傾斜した角度を反映し、立位の場合が $9.8[m/s^2]$ となり、身体が地面と水平になった場合が $0[m/s^2]$ となる。測定開始から約 1.8[s]後に転倒による衝撃加速度が発生している。転倒前は被験者が直立しているため、下方向に $9.8[m/s^2]$ の加速度が発生してい

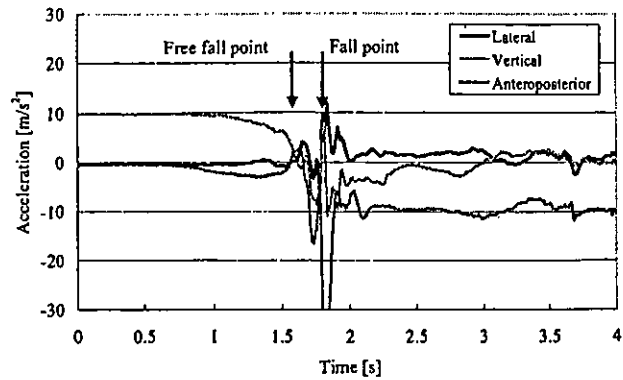

Fig.5 The acceleration waveform of imitation fall.

る。また転倒後はうつ伏せの状態であるため、前後方向の加速度が $-9.8[m/s^2]$ 生じていることがわかる。転倒により体が傾いている際には、上下方向の加速度が減少しており、自由落下の矢印の時刻に3軸の加速度すべてが $\pm 3[m/s^2]$ 以下となっている。また自由落下を検出してから実際に転倒の衝撃が発生するまでの時間は 211[ms]であった。6 名の被験者が行った計 18 回の疑似転倒すべてにおいて自由落下を示す同様の波形が観測された。Table 1 に各被験者の3回の実験において、自由落下から衝撃加速度が生じるまでの時間の平均を示す。Bの被験者がもっとも時間が短く3回の平均は78[ms]であった。またもっとも時間が長かったのはDの被験者で224[ms]であった。18回の疑似転倒における転倒の検出時間の平均は138[ms]であった。

5. 考察

実験では経験則から3軸の加速度がすべて $\pm 3[m/s^2]$ 以下の場合を自由落下であると判断して解析を行った。このため、すべての疑似転倒において、自由落下を示す波形が検出された。理論的に考えると完全な自由落下の際には3軸の加速度はほぼ $0[m/s^2]$ に収束するはずである。しかし、実際の転倒は自由落下ではなく、足が地面に接地した状態で上半身が傾斜する状態であるため、オフセットが生じていた。今回は疑似転倒の計測しか行わなかったが、日常行動をした場合に、同様の判定値で誤検出することがないかを検討する必要がある。

自由落下の検出時間はすべての被験者で100[ms]前後の値であった。転倒時にエアバッグを膨張させるとすると、自由

Table 1 The average in the period of falling of each subjects.

Subjects	Average Time[ms]	SD
A	102	34
B	78	47
C	118	52
D	224	12
E	123	4
F	185	66

落下を検出した後、衝撃が加わる 100[ms]の間に行わなければならないことになる。現在、バイク用のエアバッグが発売されているが、動作時間は約 500[ms]である。また車のエアバッグの動作時間は約 100[ms]であることを考慮すると、検出時間が短いと考えられる。今後、歩行パターンや身体の重心バランスなどの評価を行うことで、転倒を事前に予測する方法も検討する必要があると考えられる。

6. まとめ

本研究では、テレメータ通信により、被験者の加速度波形を無拘束・リアルタイムに解析可能なシステムの開発を行った。さらに、転倒を模擬した実験を行い、転倒前の特徴的な波形を検出可能かの検討を行った。実験の結果、転倒の 100～200[ms]前に自由落下を示す波形を検出可能であった。しかし、転倒の衝撃前にエアバッグなどの衝撃緩和の対策を行うには、検出する時間が短いと考えられ、今後、歩行パターンや身体の重心バランスなどの評価を行うことで、転倒を事前に予測する方法を検討する必要があることが明らかとなった。

謝辞

本研究の一部は長寿医療研究委託事業(15 公-4)の補助により行われた。

参考文献

- [1] 吉村拓巳, 長屋政博, 千原國宏, 田村俊世: 高齢者用転倒記録システムの開発とその評価, 日本生活支援工学会誌, 2 巻 1 号, 38/44 (2002)
- [2] 小河毅, 大場紀子, 和辻徹: 小型データロガーの開発, 第 40 回日本 ME 学会論文集, 第 39, 337 (2001)
- [3] 吉村拓巳, 南部雅幸, 千原國宏, 田村俊世: テレメータ型高齢者行動解析システムの開発, 第 41 回日本エム・イー学会大会, 510 (2002)
- [4] N. Özgürçin, N. Bölükbaşı, M. Beyazova and S. Orkun: Kinematic gait analysis in hemiplegic patients, *Scand. J. Rehabil. Med.*, vol. 25, 51/55 (1993).
- [5] 鈴木亮二, 大竹佐久子, 井筒岳, 岩谷力: 独居高齢者宅における生活時間調査による行動解析, 第 41 回日本エム・イー学会大会 *Japan Soc. ME & BE*, 517 (2002)
- [6] 牧川方昭, 飯泉仁美: 生体信号の無拘束計測のためのデジタル技術, *BME*, 9, 16/27 (1995)
- [7] M. Makikawa, H. Iizumi: Development of an ambulatory physical activity memory device and its application for the categorization of actions in daily life, *MEDINFO 95 Proc.*, 747/750 (1995)
- [8] J. Fahrenberg, F. Foerster, M. Smeja, W. Müller: Assessment of posture and motion by multichannel piezoresistive accelerometer recordings, *Psychophysiology*, 34, 607/612 (1997)
- [9] G. L. Smidt, J. S. Arora and R. C. Johnston: Accelerographic analysis of several types of walking, *Am. J. Phys. Med.*, 50, 285/300 (1971)
- [10] A. L. Evans, G. Duncan and W. Gilchrist, Recording accelerations in body movements, *Med. Biol. Eng. Comput.*, 29, 102/104 (1991)
- [11] T. Tamura, M. Sekine, M. Ogawa, T. Togawa and Y. Fukui: Classification of acceleration waveforms during walking by wavelet transform, *Meth. Info. Med.*, 36, 356/359 (1997)
- [12] 関根正樹, 阿部芳幸, 関本満義, 藤元登四郎, 田村俊世, 福井康裕: 腓骨頭部加速度波形を用いた片麻痺患者の歩行評価の定量化に関する検討, *電気学会論文誌 C*, 120, 1110/1117 (2000)

体表面貼付型生体モニタの開発 Development of Body Surface Mounted Monitoring System

南部 雅幸¹, 田村 俊世²

Masayuki NAMBU¹, Toshiyo TAMURA²

¹ 国立長寿医療センター, ² 千葉大学

¹ National Center for Geriatrics and Gerontology, ² Chiba University

Abstract Continuous monitoring is necessary for health control in the home. However, monitoring systems are always large and are too complicate to use. In addition, users must take it any time. We have proposed the small fall monitor, which did not obstruct the behavior, using accelerometer. In this paper, we proposed a new type of mounting method. We construct the measurement system, using flexible circuit board, and attached the system to the body surface, using biocompatible film. As the result of the experiment, this system can acquire the signal, which reflects the body movement, in comparison with the system, which we proposed before.

1. はじめに

すでに高齢社会となった我が国では、医療費の高騰にともなう健康保険、介護保険等の社会保険体制が破綻する可能性さえ危惧されている。このような状態を打開するために、健康な状態を継続的に維持することが重要であり、そのためには、日常的な健康管理が必要不可欠である。一方ユビキタスコンピューティングシステムの普及が進みつつあり、この技術を日常的な健康管理に利用することで、より詳細な健康管理の実現を目指すシステムが開発されている[1][2]。このような現状にあって、我々は、携帯可能なシステムにより行動や、転倒の計測を試みてきた[3]。これらの使用に際し、常に問題となるのは、装置を携帯する方法である。本研究では、ユビキタスコンピューティングシステムの一部として機能する生体計測システムの携帯方法について述べる。

2. 手法

2.1 従来システムと問題点

ユビキタスコンピューティングシステムを組み込んだ生体計測システム実現のためには、利用者が装置を常に携帯することが必要となる。しかしながら、利用者の行動を阻害することがないということは最低限の条件であるが、24時間の携帯には利用者の強いモチベーションが必要であり、疾患を有することがないいわゆる健康な状態では、発生するかどうかすら不明な将来的な疾患のために装置の携帯を促進することは困難である。また、仮に強いモチベーションを持つ利用者においても入浴、就寝時などには装置を携帯することが制限される。さらに、痴呆の症状を有する患者の場合は、自発的な携帯は困難である。これらの問題を解決するため、我々は装置を可能な限り小型化することで対応してきた。しかしながら利用者の行動を阻害しないという条件は解決できたものの、依然として自発的な携帯を必要としていることには変わりはない。近い将来、生体内への計測システムの埋め込みすなわちインプラントの技術が実現される可能性は高いが、現時点では健康な生体内に侵襲を伴う装置の埋め込みは技術的な条件はクリアできても倫理的問題があり、利用者と利用を促進する医療関係者の双方に抵抗感があることは否めない。我々は、これまでのシステムを改良し、体表面に貼付する装置を提案する。

2.2 体表面貼付型計測システム

通常肩胛骨直下の腰背部表面は比較的感覚が鈍く、ここに比較的厚みを減らした計測装置を構成し貼り付けることで行動をほとんど制限しない計測システムの構成が実現可能となる。そこで、Fig. 1に示すように計測回路、データ処理および保存回路をフレキシブルな基板上に構成し、防水シートでシールした上で生体適合性のあるフィルムシートで体表面に貼り付ける。これにより、利用者の行動を阻害しないシステムが実現できるだけでなく、着衣の上から獲得不可能な体温などの情報も獲得可能となる。

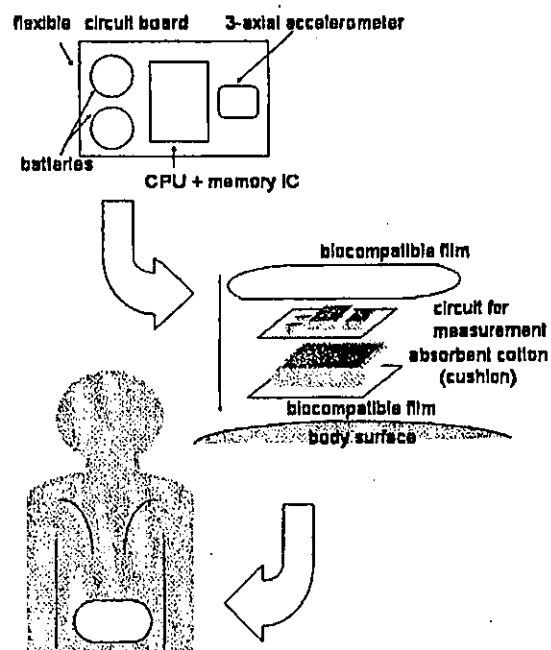

Fig1. Arrangement of the body surface mounted monitoring system

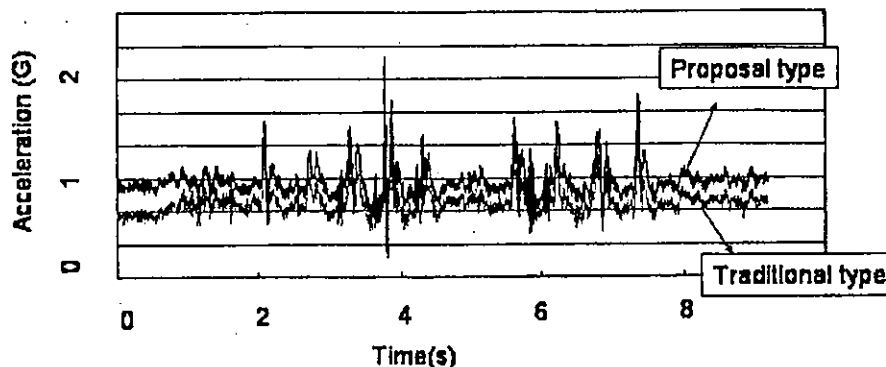

Fig.2 Signal of Acceleration (Vertical direction)

3. 実験と結果

3.1 装置

本システムの有効性を確認するため、評価用システムを構成し計測を行った。加速度センサおよびデータロガー回路を基板上に構成し、緩衝剤として脱脂綿を体表側に挿入した。さらにポリスチレンで密閉した上でポリエチレン製防水フィルム（バンドエイド社製やわらか防水フィルム[4]）で人体に貼付した。貼付に使用した防水フィルムは防水機能を有する一方、空気および水蒸気を透過するため、従来の絆創膏などの粘着テープに比べ長時間の貼付を可能としている。計測装置の厚みは緩衝材を含み約10mmであった。これを背面腰部に貼付し歩行時の加速度を計測した。また比較のため携帯型の加速度センサを装着した。このセンサはベルトに固定し着衣の上から装着した。

3.2 結果

Fig.2に計測データを示す。獲得された信号から、ほぼ同様の信号が獲得されており、歩行の携帯や転倒検出に本システムが利用可能であることが確認できた。また、本システムにより獲得されたデータ中に従来システムによるデータには見られない周波数成分が確認できた。

実験では連続で4時間装着した。その結果発汗の集中がみられたが発赤等皮膚疾患につながる症状は確認できなかった。また、装着直後には若干の違和感があるものの連続して装着することで違和感は気にならない程度に低下した。

4. 考察

実験結果より、計測装置を体表面に貼付した場合と、着衣の上から装着した場合を比較した場合、確認できる周波数成分の相違は、固定が不十分なため装着用具により本来存在した成分が吸収された可能性が推測される。着衣の上から固定する場合、体幹部の動きと全く同様な状態に固定すると利用者の行動を阻害することになり本装置の目的を達成できない。一方、余裕をもって固定する場合、本実験で認められるようなフィルタ効果や位相遅れが発生する可能性がある。このような現象は、歩行形態の解析等のために周波数解析の手法を適用する際外乱となり、その結果に悪影響を与えることが予想される。本システムのように体表面に直接貼付・固定することで、この影響をほぼゼロにすることが可能である。

実験では、センサとデータロガーを組み合わせた構成とし

たが、ユビキタスコンピューティングシステムの一部として機能させるためには、無線ネットワークを構築する必要がある。そのためには、バッテリーの持続時間が問題となるが、従来提案されているシステムに比べ厚みの制約は厳しくなるが面積の制約は緩和されるため充電電池等の利用も容易である。

現時点では市販の水蒸気透過性防水フィルムを利用しており蒸れが緩和されていることが確認されているが、基板その他の計測装置本体にはこのような機能がないため発汗の集中が認められた。この問題については基板をいくつかのユニットに分割しその隙間から水蒸気を逃がす等の工夫が必要である。また、実際の運用には最低でも24時間の連続貼付が必要であると思われ、そのためにより長時間貼付が可能な貼付用フィルムを開発する必要がある。

5. まとめ

日常的な健康管理を目的とした生体計測システムにユビキタスコンピューティングシステムを導入する際に必要となる計測システムの携帯性を改善する手法について述べた。実験の結果、本装置は利用者の行動を阻害することなく長時間の装着・計測が可能であることが確認された。また、体表面に貼付することで、従来獲得できなかった情報の獲得が可能になり、さらに着衣上からの装着で発生する外乱成分の低減も可能であることが確認された。

謝辞

本研究の一部は長寿医療研究委託事業 15 公によって行われた。

参考文献

- [1] 南部雅幸, 中島一樹, 田村俊世, “高齢者のための高齢者自立・介護支援”, 計測と制御, 40/5, pp368-369, 2001
- [2] 松岡克典, “住宅内行動の長期蓄積に基づく異常検知手法の検討”, 電子情報通信学会技術研究報告, ME とパイオサイバネティクス, 102/726, pp65-68, 電磁情報通信学会
- [3] 吉村 拓巳; 堀内 郁幸; 東 祐二; 中島 一樹; 藤元 登四郎; 千原 國宏; 田村 俊世, “老人転倒モニタの開発とその評価”, 電気学会論文誌 C, 120/12, pp1846-1853, 2001
- [4] やわらか 防水 フィルム 製品情報 ホームページ, “<http://www.inj.co.jp/consumer/bandaaid/products/bandaaid/ilm.html>”, ジョンソンエンドジョンソン株式会社

The influence of floor material on standing and walking by hemiplegic patients

Yutaka KUWAE¹, Tadahiko YUJI¹, Yuji HIGASHI¹, Toshiro FUJIMOTO¹, Masaki SEKINE² and Toshiyo TAMURA²

¹ Fujimoto Hayasuzu Hospital, Miyazaki, Japan

² Faculty of Engineering, Chiba University, Chiba, Japan

Abstract— In this study, we evaluated the influence of floor materials on standing and walking in hemiplegic patients. To monitor body motion during standing and walking without any constraint, we used a measurement system that consisted of an accelerometer device, a telemeter system, and a personal computer. The posture angles in the antero-posterior and lateral directions were calculated from the low frequency component of the acceleration signal to evaluate body motion. Experiments were performed with six poststroke hemiplegic patients. We modified the TIME UP & GO TEST introduced by Podsiadle. The patients executed the task on three different floor materials: wooden flooring, linoleum, and carpet. The posture angle pattern on carpet differed from those on wooden flooring and linoleum. Therefore, the floor material influenced body motion. We suspect that this difference in movement corresponds to the hardness of the material.

Keywords— floor material, hemiplegic patients, standing, walking, body motion

I. INTRODUCTION

To compensate for the decline in walking ability in poststroke hemiplegic patients, an ankle foot orthotic (AFO) is used to secure clearance during the swing phase, to increase the stability of the foot joint, and to control the knee joint during the stance phase. However, patients claim that it is difficult to walk under some situations, even when wearing the AFO, i.e., in some environments the AFO does not play a major role. Several floor materials are used indoors in hospitals and nursing homes, including wooden flooring (hereafter referred to as flooring), linoleum, and carpeting. These materials influence the standing and walking environment. We need to evaluate how the ease of walking depends on the floor materials.

In this study, we evaluated the influence of floor material on standing and walking in hemiplegic patients.

II. METHODOLOGY

A. Measurement system

The measurement system consisted of an accelerometer device, a telemeter system (Nihon Kohden Co, Japan), and a personal computer (PC) to record body motion during standing and walking with no constraints.

The accelerometer device included a tri-axial piezo-resistive accelerometer (Akebono Brake Co, Japan), amplifiers, and low-pass filters. Its dimensions, weight,

measurement range, and frequency band were 30×40×20 mm (W×H×D), 20 g, ±2 G, and 0-100 Hz, respectively. The device was attached to the back in the lumbosacral region. The transmitter measured 128×80×280 mm and weighed ca. 300 g. The subject carried the accelerometer device and transmitter during measurements. The acceleration signal was recorded on the PC at a sampling frequency of 256 Hz via the receiver.

B. Experimental design

The experiment was performed with six poststroke hemiplegic patients and one normal subject.

We modified the TIME UP & GO TEST introduced by Podsiadle as the task. The details of the task were as follows:

1. We placed two chairs with armrests 3 m apart.
2. The subject sat on a chair (46 cm in height) with his/her hands on the armrest.
3. The patients stood up on the GO sign and walked toward the other chair at their own speed, using a cane and a plastic AFO that was used during physical training.
4. After practicing the task once, a recording was made.

The patient executed the task on three different floor materials: flooring, linoleum, and carpet.

After the recording, the low-frequency components of the acceleration signals were extracted using 8th order Butterworth filters with a 0.5-Hz cutoff frequency. The low-frequency components were used to estimate the posture angles, since the accelerometer measured the gravitational acceleration as DC.

This study was approved by the ethics committee of Fujimoto Hayasuzu Hospital. We explained the aim and procedure of the experiment to each subject and obtained written informed consent.

III. RESULTS

The posture angles are shown in Figs. 1 and 2. Fig. 1 shows a typical change in posture angle from sitting to walking in a normal subject. No significant difference with different floor materials was observed in the antero-posterior or lateral directions.

The typical examples of the posture angles in the antero-posterior and lateral directions in a right hemiplegic patient are shown in Fig. 2. The changes in angle pattern in the

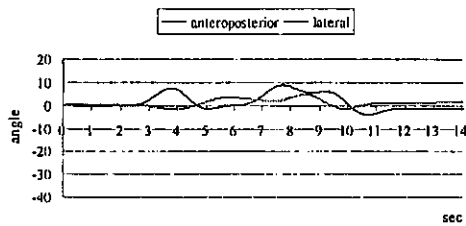

a) Wooden Flooring

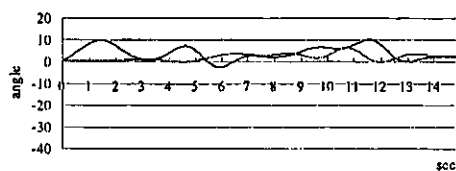

b) Linoleum

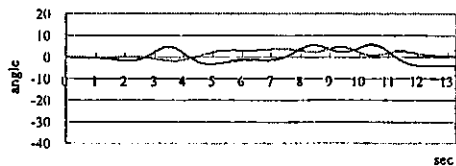

c) Carpet

Fig.1. Typical examples of posture angles in the normal subject. The positive values in the anteroposterior and lateral directions indicated the backward and the leftward tilt, respectively.

antero-posterior direction were similar on linoleum and flooring. During the transition from the sitting to the standing phase, the posture gradually inclined forward with several peaks. The subject inclined forward and maintained that angle. The posture in the lateral direction during standing differed on flooring and linoleum. The change in angle on linoleum was larger than that on linoleum. During walking, these angles fluctuated around a specific value in both cases. The normal subject maintained a forward angle during walking (blue line in Fig. 1), while the hemiplegic patient could not. The patient maintained a little forward tilt, which fluctuated periodically..

By contrast, the posture angles on carpet differed completely. The patient began the standing motion with a backward movement. Then, rapid forward movement was observed. These movements were not observed on flooring or linoleum. The change in posture angle was forward in the anteroposterior direction after that time. At the end of walking, the posture angle in the anteroposterior direction

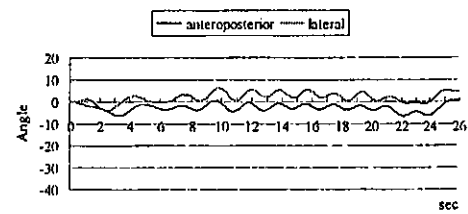

a) Wooden Flooring

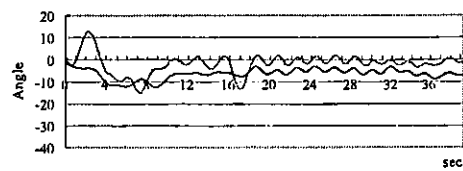

b) Linoleum

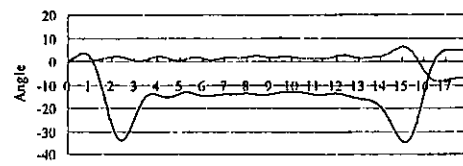

c) Carpet

Fig.2. Typical examples of posture angles in the hemiplegic patient. The positive values in the anteroposterior and lateral directions indicated the backward and the leftward tilt, respectively.

decreased and then recovered rapidly. The patient kept the center in the lateral direction through the task.

IV. DISCUSSION

The center of gravity in the standing position is located near the sacrum. In this study, an accelerometer device was attached near the center of gravity. The posture angle estimated from the acceleration signals during standing and walking on carpet differed from those on flooring and linoleum, suggesting that the movement of the center of gravity depended on the floor material.

We believe that this difference in movement corresponds to the hardness of the material. Floor material with a high degree of hardness can provide a sufficient reaction force to control the basic functions of the AFO. The hemiplegic patients could control their movements easily on flooring and linoleum, since they are harder than carpet.

The patient used a small counter-reaction at the